

TUSB1104 USB Type-C™ 10 Gbps USB 3.2 x2 Adaptive Linear Redriver

1 Features

- USB 3.2 5 Gbps and 10 Gbps support
 - USB 3.2 x2 support up to 20 Gbps (10 Gbps × 2 = 20 Gbps)
- Advanced USB power management
 - Active: 550 mW (typical)
 - Disconnect: 1.5 mW
 - Disabled (EN = L): 0.130 mW
- 16 EQ settings up to 12 dB at 5 GHz
- Choice between adaptive or fixed receiver equalization for ports facing USB connector
- Choice between linear or limited redriver for ports facing the system (SSRX1/2 transmitters)
- Less than 1 V V_{TX-CM} and V_{RX-CM}
- Configuration through I²C or pin-strap
- Selection between 1.8 V or 3.3 V I²C levels
- Operates from a single 3.3 V supply

2 Applications

- [Notebooks and desktops](#)
- [Docking stations](#)
- [Data storage](#)
- [Connected peripherals and printers](#)

Description

The TUSB1104 is a 10 Gbps USB 3.2 x2 linear redriver for USB-C applications enabling up to 20 Gbps total data throughput. The TUSB1104 is intended to reside between a Host and a USB-C receptacle or between a USB device and a USB-C receptacle. The TUSB1104 supports both USB 3.2 Gen2 (10 Gbps) and Gen1 (5 Gbps) as well as USB 3.2 low power states (Disconnect, U1, U2, and U3).

The TUSB1104 incorporates an innovative, adaptive receiver equalization (AEQ) feature. The AEQ feature will automatically determine what it believes is the best ISI compensation settings between the TUSB1104 and USB device plugged into the USB connector resulting in improved interoperability.

The TUSB1104 operates from a single 3.3 V supply and is available in a 40-pin WQFN package.

Device Information⁽¹⁾

PART NUMBER	PACKAGE	BODY SIZE (NOM)
TUSB1104	WQFN (40)	4.00 mm × 6.00 mm

(1) For all available packages, see the orderable addendum at the end of the data sheet.

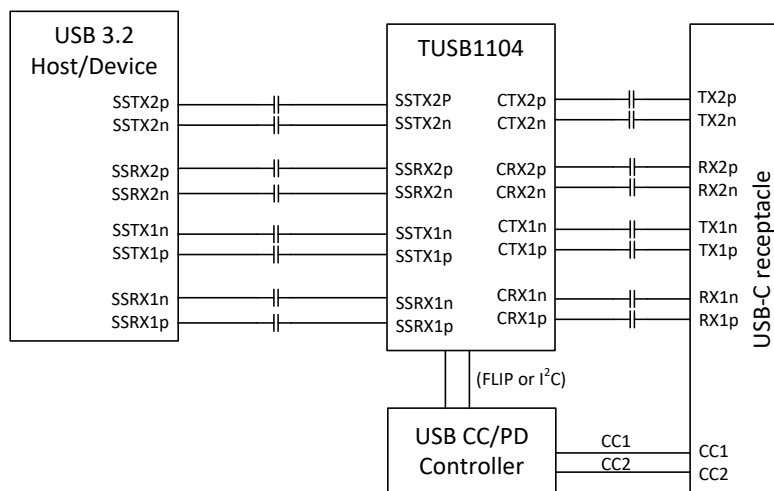

Simplified Schematic



Table of Contents

1 Features	1	7.6 Register Map.....	32
2 Applications	1	8 Application and Implementation	41
3 Revision History	2	8.1 Application Information.....	41
4 Pin Configuration and Functions	3	9 Typical Application	41
5 Specifications	6	10 Design Requirements	42
5.1 Absolute Maximum Ratings.....	6	11 Detailed Design Procedure	42
5.2 ESD Ratings.....	6	11.1 USB SSTX1/2 Receiver Configuration.....	44
5.3 Recommended Operating Conditions.....	6	11.2 USB CRX1/2 Receiver Configuration.....	44
5.4 Thermal Information.....	6	12 Application Curves	45
5.5 Power Supply Characteristics.....	7	13 Power Supply Recommendations	45
5.6 Control I/O DC Electrical Characteristics.....	7	14 Layout	45
5.7 USB Electrical Characteristics.....	9	14.1 Layout Guidelines.....	45
5.8 Timing Requirements.....	11	14.2 Layout Example.....	46
5.9 Switching Characteristics.....	12	15 Device and Documentation Support	47
5.10 Typical Characteristics.....	13	15.1 Receiving Notification of Documentation Updates..	47
6 Parameter Measurement Information	15	15.2 Support Resources.....	47
7 Detailed Description	18	15.3 Trademarks.....	47
7.1 Overview.....	18	15.4 Electrostatic Discharge Caution.....	47
7.2 Functional Block Diagram.....	19	15.5 Glossary.....	47
7.3 Feature Description.....	20	16 Mechanical, Packaging, and Orderable Information	47
7.4 Device Functional Modes.....	24		
7.5 Programming.....	26		

3 Revision History

DATE	REVISION	NOTES
April 2022	*	Initial Release

4 Pin Configuration and Functions

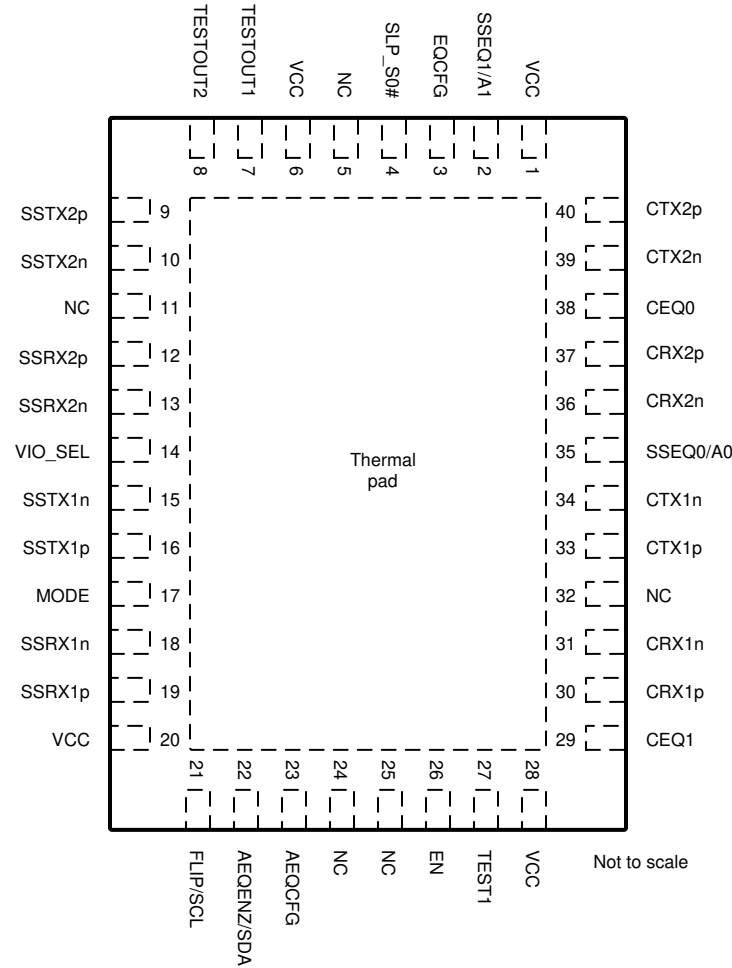

Figure 4-1. TUSB1104 RNQ Package, 40-Pin WQFN (Top View)

Table 4-1. Pin Functions

PIN		TYPE ⁽¹⁾	DESCRIPTION
NAME	NO.		
VCC	1	P	3.3 V supply
SSEQ1/A1	2	4-level I (PU/PD)	In I2C mode, this pin along with A0 pin selects the 7-bit I2C target address (refer to Table 7-8). In pin-strap mode, this pin along with SSEQ0 selects the receiver EQ for SSTX1 and/or SSTX2 (refer to Table 7-3).
EQCFG	3	4-level I (PU/PD)	In pin-strap mode, this controls how CEQ[1:0] pins and SSEQ[1:0] are used. Refer to Section 7.4.2 for details. In I2C mode, this pin is for TI internal test and must be left floating for normal operation.
SLP_S0#	4	I (PU)	SLP_S0#. This pin will control whether or not Rx.Detect function is enabled. If this pin is low and device is in Disconnect state, Rx termination will be disabled. If this pin is low and device is U2/U3 state, Rx termination will be enabled. 1: Rx.Detect Enabled. 0: Rx.Detect Disabled.
NC	5		No internal connection.
VCC	6	P	3.3 V supply
TESTOUT1	7	O	For internal TI test only. For normal operation this pin should be left unconnected.
TESTOUT2	8	O	For internal TI test only. For normal operation this pin should be left unconnected.

Table 4-1. Pin Functions (continued)

PIN		TYPE ⁽¹⁾	DESCRIPTION
NAME	NO.		
SSTX2p	9	I	Differential positive input for USB port 2. Should be connected to USB 3.2 Host transmit port through an external 220 nF AC-coupling capacitor.
SSTX2n	10	I	Differential positive input for USB port 2. Should be connected to USB 3.2 Host transmit port through an external 220 nF AC-coupling capacitor.
NC	11		No internal connection.
SSRX2p	12	O	Differential positive output for USB port 2. Should be connected to USB 3.2 Host receiver port through an external 220 nF AC-coupling capacitor.
SSRX2n	13	O	Differential negative output for USB port 2. Should be connected to USB 3.2 Host receiver port through an external 220 nF AC-coupling capacitor.
VIO_SEL	14	4-level I (PU/PD)	Selects the input thresholds for I2C (SDA and SCL). "0": I2C 3.3 V "R": I2C 1.8 V "F": I2C 3.3 V. "1": I2C 1.8 V.
SSTX1n	15	I	Differential negative input for USB port 1. Should be connected to USB 3.2 Host transmit port through an external 220 nF AC-coupling capacitor.
SSTX1p	16	I	Differential positive input for USB port 1. Should be connected to USB 3.2 Host transmit port through an external 220 nF AC-coupling capacitor.
MODE	17	4-level I (PU/PD)	This pin selects whether device is in I2C mode or pin-strap mode. Refer to Table 7-5 for details.
SSRX1n	18	O	Differential negative output for USB port 1. Should be connected to USB 3.2 Host receiver port through an external 220 nF AC-coupling capacitor.
SSRX1p	19	O	Differential positive output for USB port 1. Should be connected to USB 3.2 Host receiver port through an external 220 nF AC-coupling capacitor.
VCC	20	P	3.3 V supply
FLIP/SCL	21	I	In I2C mode, this pin functions as I2C clock. In pin-strap mode, this pin controls which lane is the config lane (Refer to Table 7-4).
AEQENZ/SDA	22	I/O	In I2C mode, this pin functions as I2C data. In pin-strap mode, this pin controls whether or not AEQ is enabled. 0: AEQ enabled 1: AEQ disabled
AEQCFG	23	4-level I (PU/PD)	In pin-strap mode, this pin controls the FULLAEQ_UPPER_EQ limit. In I2C mode, this function is controlled by the FULLAEQ_UPPER_EQ register. "0": FULLAEQ_UPPER_EQ = Ah "R": FULLAEQ_UPPER_EQ = Fh "F": FULLAEQ_UPPER_EQ = 8h "1": FULLAEQ_UPPER_EQ = Ch
NC	24		No internal connection
NC	25		No internal connection
EN	26	I (PU)	When low, the differential receiver's termination will be disabled and differential drivers will be disabled. On rising edge of EN, device will sample four-level inputs and function based on the sampled state of the pins. This pin has a internal 500k pull-up to VCC. Please note this pin will also reset internal configuration registers.
TEST1	27	I	TI Test1. Under normal operations this pin shall be connected directly or pulled up to VCC.
VCC	28	P	3.3 V supply
CEQ1	29	4-level I (PU/PD)	In pin-strap mode, this pin along with CEQ0 selects the receiver EQ for CRX1 and/or CRX2 (Refer to Table 7-2).
CRX1p	30	I	Differential positive input for USB port 1. Should be connected to RX1p pin of USB connector. Connection can be DC-coupled to USB connector. Optionally, connection can be through an external 330 nF AC-coupling capacitor.
CRX1n	31	I	Differential negative input for USB port 1. Should be connected to RX1n pin of USB connector. Connection can be DC-coupled to USB connector. Optionally, connection can be through an external 330 nF AC-coupling capacitor.

Table 4-1. Pin Functions (continued)

PIN		TYPE ⁽¹⁾	DESCRIPTION
NAME	NO.		
NC	32		No internal connection.
CTX1p	33	O	Differential positive output for USB port 1. Should be connected to TX1p pin of USB connector through an external 220 nF AC-coupling capacitor.
CTX1n	34	O	Differential negative output for USB port 1. Should be connected to TX1n pin of USB connector through an external 220 nF AC-coupling capacitor.
SSEQ0/A0	35	4-level I (PU/PD)	In I2C mode, this pin along with A1 pin selects the 7-bit I2C target address (refer to Table 7-8). In pin-strap mode, this pin along with SSEQ1 selects the receiver EQ for SSTX1 and/or SSTX2 (refer to Table 7-3).
CRX2n	36	I	Differential negative input for USB port 2. Should be connected to RX2n pin of USB connector. Connection can be DC-coupled to USB connector. Optionally, connection can be through an external 330 nF AC-coupling capacitor.
CRX2p	37	I	Differential positive input for USB port 2. Should be connected to RX2p pin of USB connector. Connection can be DC-coupled to USB connector. Optionally, connection can be through an external 330 nF AC-coupling capacitor.
CEQ0	38	4-level I (PU/PD)	In pin-strap mode, this pin along with CEQ1 selects the receiver EQ for CRX1 and/or CRX2 (Refer to Table 7-2).
CTX2n	39	O	Differential negative output for USB port 2. Should be connected to TX2n pin of USB connector through an external 220 nF AC-coupling capacitor.
CTX2p	40	O	Differential positive output for USB port 2. Should be connected to TX2p pin of USB connector through an external 220 nF AC-coupling capacitor.
Thermal Pad		G	Thermal pad. Connect to a solid ground plane.

(1) I = Input, O = Output, I/O = Input or Output, G = Ground, P = Power, PD = Internal Pull-down, PU = Internal Pull-up.

5 Specifications

5.1 Absolute Maximum Ratings

over operating free-air temperature range (unless otherwise noted)⁽¹⁾

		MIN	MAX	UNIT
Supply Voltage Range	V _{CC}	-0.3	4	V
Voltage Range at any input or output pin	Differential voltage between positive and negative inputs	-2.5	2.5	V
	Voltage at differential inputs	-0.5	4	V
	CMOS Inputs	-0.5	4	V
Maximum junction temperature, T _J	TUSB1104		105	°C
	TUSB1104I		125	°C
Storage temperature, T _{stg}		-65	150	°C

- (1) Operation outside the *Absolute Maximum Ratings* may cause permanent device damage. Absolute maximum ratings do not imply functional operation of the device at these or any other conditions beyond those listed under *Recommended Operating Conditions*. If briefly operating outside the *Recommended Operating Conditions* but within the *Absolute Maximum Ratings*, the device may not sustain damage, but it may not be fully functional. Operating the device in this manner may affect device reliability, functionality, performance, and shorten the device lifetime.

5.2 ESD Ratings

			VALUE	UNIT
V _(ESD)	Electrostatic discharge	Human-body model (HBM), per ANSI/ESDA/JEDEC JS-001 ⁽¹⁾	±2000	V
		Charged-device model (CDM), per ANSI/ESDA/JEDEC JS-002 ⁽²⁾	±1500	

- (1) JEDEC document JEP155 states that 500-V HBM allows safemanufacturing with a standard ESD control process.
(2) JEDEC document JEP157 states that 250-V CDM allows safemanufacturing with a standard ESD control process.

5.3 Recommended Operating Conditions

over operating free-air temperature range (unless otherwise noted)

		MIN	NOM	MAX	UNIT
V _{CC}	Main power supply	3.0	3.3	3.6	V
	Main supply ramp requirement	0.1		50	ms
V _(I2C)	Supply that external resistors are pulled up to for both SDA and SCL pins	1.7		3.6	V
V _(PSN)	Supply Noise on V _{CC} pins (less than 4MHz)			50	mVpp
T _A	TUSB1104 Operating free-air temperature	0		70	°C
	TUSB1104I Operating free-air temperature	-40		85	°C

5.4 Thermal Information

	THERMAL METRIC ⁽¹⁾	TUSB1104	UNIT
		RNQ (WQFN)	
		40 PINS	
R _{θJA}	Junction-to-ambient thermal resistance	31.4	°C/W
R _{θJC(top)}	Junction-to-case (top) thermal resistance	21.8	°C/W
R _{θJB}	Junction-to-board thermal resistance	12.2	°C/W
ψ _{JT}	Junction-to-top characterization parameter	0.3	°C/W
ψ _{JB}	Junction-to-board characterization parameter	12.2	°C/W
R _{θJC(bot)}	Junction-to-case (bottom) thermal resistance	4.3	°C/W

- (1) For more information about traditional and new thermalmetrics, see the [Semiconductor and IC Package Thermal Metrics](#) application report.

5.5 Power Supply Characteristics

over operating free-air temperature range (unless otherwise noted)

PARAMETER		TEST CONDITIONS	MIN	TYP	MAX	UNIT
$P_{ACTIVE-USB-2Ports}$	Average active power USB Only for both port1 and port2	Link in U0 with GEN2 data transmission; EQ control pins = NC; PRBS7 pattern at 10 Gbps, $V_{ID} = 1000$ mV _{PP} ; Linear redriver mode; LINR_L3; EN = H;		550		mW
$P_{ACTIVE-USB-1Port}$	Average active power USB Only for single port.	Link in U0 with GEN2 data transmission; EQ control pins = NC; PRBS7 pattern at 10 Gbps, $V_{ID} = 1000$ mV _{PP} ; LINR_L3; EN = H;		275		mW
$P_{NC-USB-SLP\#}$	Average power with no connection with SLP_S0#	No USB3.2 GEN2 device is connected to CTX1; EN = H; SLP_S0#;		0.13		mW
$P_{NC-USB-1Port}$	Average power with no connection	No USB3.2 GEN2 device is connected to CTX1; EN = H;		1.5		mW
$P_{U2U3-SLP\#}$	Average power in U2/U3 with SLP_S0#	Link in U2 or U3; EN = H; SLP_S0# = L;		0.24		mW
$P_{U2U3-1Port}$	Average power in U2/U3	Link in U2 or U3; EN = H;		1.9		mW
$P_{DISABLED-I2C}$	Device Disabled power in I2C Mode	MODE = "F"; EN = H; CTLSEL = 0h;		0.108		mW
$P_{DISABLED}$	Device Disabled power in pin-strap	MODE != "F"; EN = L;		0.130		mW

5.6 Control I/O DC Electrical Characteristics

over operating free-air temperature range (unless otherwise noted)

PARAMETER		TEST CONDITIONS	MIN	TYP	MAX	UNIT
4-level Inputs						
4-Level V_{TH}	Threshold 0 / R	$V_{CC} = 3.3$ V		0.55		V
4-Level V_{TH}	Threshold R/ Float	$V_{CC} = 3.3$ V		1.65		V
4-Level V_{TH}	Threshold Float / 1	$V_{CC33} = 3.3$ V		2.7		V
I_{IH}	High level input current with internal resistors disabled.	$V_{CC} = 3.6$ V; $V_{IN} = 3.6$ V	-5		5	μ A
I_{IL}	Low level input current with internal resistors disabled	$V_{CC} = 3.6$ V; $V_{IN} = 0$ V	-1		1	μ A
I_{IH-REN}	High level input current with internal resistors enabled.	$V_{CC} = 3.6$ V; $V_{IN} = 3.6$ V	20		60	μ A
I_{IL-REN}	Low level input current with internal resistors enabled.	$V_{CC} = 3.6$ V; $V_{IN} = 0$ V	-100		-40	μ A
R_{PU}	Internal pull-up resistance			48		k Ω
R_{PD}	Internal pull-down resistance			98		k Ω
2-State CMOS Input (EN, SLP_S0#)						
V_{IH}	High-level input voltage		1.2		3.6	V
V_{IL}	Low-level input voltage		-0.3		0.6	V
R_{PU}	Internal pull-up resistance (EN, SLP_S0#)		250	400	550	k Ω
I_{IH}	High-level input current (EN, SLP_S0#)	$V_{IN} = 3.6$ V; MODE != "F"; VIO_SEL = "0" or "R";	-5		5	μ A
I_{IL}	Low-level input current (EN, SLP_S0#)	$V_{IN} = GND$, $V_{CC} = 3.6$ V; MODE != "F"; VIO_SEL = "0" or "R";	-11		11	μ A
I²C Control Pins (SCL, SDA)						
V_{IH_1p8V}	High-level input voltage when configured for 1.8V I2C level	MODE = "F"; VIO_SEL = "R" or "1";	1.2		3.6	V
V_{IL_1p8V}	Low-level input voltage when configured for 1.8V I2C level	MODE = "F"; VIO_SEL = "R" or "1";	-0.3		0.6	V
V_{IH_3p3V}	High-level input voltage when configured for 3.3V I2C level	MODE = "F"; VIO_SEL = "0" or "F";	2.0		3.6	V
V_{IL_3p3V}	Low-level input voltage when configured for 3.3V I2C level	MODE = "F"; VIO_SEL = "0" or "F";	-0.3		0.8	V

5.6 Control I/O DC Electrical Characteristics (continued)

over operating free-air temperature range (unless otherwise noted)

PARAMETER		TEST CONDITIONS	MIN	TYP	MAX	UNIT
V _{OL}	Low-level output voltage	MODE = "F"; I _{OL} = 6 mA	0		0.4	V
I _{OL}	Low-level output current	MODE = "F"; V _{OL} = 0.4 V	20			mA
I _{I(I2C)}	Input current	0.1 x V _{I(I2C)} < Input voltage < 3.3 V	-1		1	μA
C _{I(I2C)}	Input capacitance				10	pF
C _(I2C_FM+_BUS)	I2C bus capacitance for FM+ (1MHz)				150	pF
C _(I2C_FM_BUS)	I2C bus capacitance for FM (400kHz)				150	pF
R _(EXT_I2C_FM+)	External resistors on both SDA and SCL when operating at FM+ (1MHz)	C _(I2C_FM+_BUS) = 150 pF	620	820	910	Ω
R _(EXT_I2C_FM)	External resistors on both SDA and SCL when operating at FM (400kHz)	C _(I2C_FM_BUS) = 150 pF	620	1500	2200	Ω

5.7 USB Electrical Characteristics

over operating free-air temperature and voltage range (unless otherwise noted)

PARAMETER		TEST CONDITIONS	MIN	TYP	MAX	UNIT
USB Gen 2 Differential Receiver (CRX1p/n, CRX2p/n, SSTX1p/n, SSTX2p/n)						
$V_{(RX-DIFF-PP)}$	Input differential peak-peak voltage swing linear dynamic range	AC-coupled differential peak-to-peak signal measured post CTLE through a reference channel		1200		mVpp
$V_{(RX-DC-CM)}$	Common-mode voltage bias in the receiver (DC)			0		V
$V_{RX_CM-INST}$	Max Instantaneous RX DC common mode voltage change under all operating conditions (OFF to ON, Disabled to USB, etc...)	Measured at non-device side of AC coupling capacitor with 200-k Ω load.	-300		500	mV
$R_{(RX-DIFF-DC)}$	Differential input impedance (DC)	Present after a GEN2 device is detected.	72	90	120	Ω
$R_{(RX-CM-DC)}$	Receiver DC common mode impedance	Present after a GEN2 device is detected.	18		30	Ω
$Z_{(RX-HIGH-IMP-DC-POS)}$	Common-mode input impedance with termination disabled (DC)	Present when no GEN2 device is detected on transmitter. Measured over the range of 0 – 500 mV with respect to GND.	25			k Ω
$V_{(SIGNAL-DET-DIFF-PP)}$	Input differential peak-to-peak signal detect assert level	At 10 Gbps, no input loss, PRBS7 pattern		75		mV
$V_{(RX-IDLE-DET-DIFF-PP)}$	Input differential peak-to-peak signal detect de-assert Level	At 10 Gbps, no input loss, PRBS7 pattern		55		mV
$V_{(RX-LFPS-DET-DIFF-PP)}$	Low frequency periodic signaling (LFPS) detect threshold	Below the minimum is squelched	100		300	mV
$V_{(RX-CM-AC-P)}$	Peak RX AC common-mode voltage	Measured at package pin			150	mV
$C_{(RX)}$	RX input capacitance to GND	At 5 GHz;			1	pF
$R_{L(RX-DIFF)}$	Differential return Loss	50 MHz – 1.25 GHz at 85 Ω ;		-22		dB
		5 GHz at 85 Ω ;		-20		dB
$R_{L(RX-CM)}$	Common-mode return loss	50 MHz – 5 GHz at 85 Ω ;		-12		dB
E_{Q_SSTX15}	SSTX1->CTX1 Receiver equalization at 5 GHz	SSEQ1_SEL = 15; Gain at 5 GHz minus Gain at 10 MHz;		13.6		dB
E_{Q_RX15}	CRX1 -> SSRX1 Receiver equalization at 5 GHz	CEQ1_SEL = 15; Gain at 5 GHz minus Gain at 10 MHz;		12.7		dB
$C_{AC-USB1}$	Required external AC capacitor on SSTX1/2		75		265	nF
$C_{AC-USB2}$	Optional external AC capacitor on CRX1 and CRX2.		297		363	nF
USB Gen 2 Differential Transmitter (CTX1p/n, CTX2p/n, SSRX1p/n, SSRX2p/n)						
$V_{TX(DIFF-PP)}$	Transmitter dynamic differential voltage swing range.	EQ15; VID = 1Vpp; LINR_L3		1200		mVpp
$V_{TX(RCV-DETECT)}$	Amount of voltage change allowed during receiver detection				600	mV
$V_{TX-CM-INST-ONOFF}$	Max Instantaneous TX DC common mode voltage change under operating condition: OFF to ON, ON to OFF, during Rx.Detect; Disconnect to U0, U2/U3 to Disconnect.	Measured single-ended at non-device side of AC coupling capacitor with 200-k Ω load.	-500		800	mV
$V_{TX(CM-IDLE-DELTA)}$	Transmitter idle common-mode voltage change while in U2/U3 and not actively transmitting LFPS		-300		600	mV
$V_{TX(DC-CM)}$	Common-mode voltage bias in the transmitter (DC)		0.5	0.76	1	V
$V_{TX(CM-AC-PP-ACTIVE)}$	Tx AC common-mode voltage active	Max mismatch from Txp + Txn for both time and amplitude			100	mVpp
$V_{TX(IDLE-DIFF-AC-PP)}$	AC electrical idle differential peak-to-peak output voltage	At package pins	0		10	mV
$V_{TX(CM-DC-ACTIVE-IDLE-DELTA)}$	Absolute DC common-mode voltage between U1 and U0	At package pin			200	mV
$R_{TX(DIFF)}$	Differential impedance of the driver		80	90	120	Ω

5.7 USB Electrical Characteristics (continued)

over operating free-air temperature and voltage range (unless otherwise noted)

PARAMETER		TEST CONDITIONS	MIN	TYP	MAX	UNIT
R _{TX(CM)}	Common-mode impedance of the driver	Measured with respect to AC ground over 0–500 mV	18		30	Ω
V _{SSRX-LIMITED-VODL0}	SSRX differential peak-to-peak voltage when configured for limited redriver and LINR_L0	TX_PRESHOOT_EN = 0; TX_DEEMPHASIS_EN = 0;		750		mVpp
V _{SSRX-LIMITED-VODL1}	SSRX differential peak-to-peak voltage when configured for limited redriver and LINR_L1	TX_PRESHOOT_EN = 0; TX_DEEMPHASIS_EN = 0;		900		mVpp
V _{SSRX-LIMITED-VODL2}	SSRX differential peak-to-peak voltage when configured for limited redriver and LINR_L2	TX_PRESHOOT_EN = 0; TX_DEEMPHASIS_EN = 0;		1000		mVpp
V _{SSRX-LIMITED-VODL3}	SSRX differential peak-to-peak voltage when configured for limited redriver and LINR_L3	TX_PRESHOOT_EN = 0; TX_DEEMPHASIS_EN = 0;		1100		mVpp
V _{SSRX-DE-RATIO0}	SSRX de-emphasis when configured for limited redriver and de-emphasis enabled.	TX_PRESHOOT_EN = 0; TX_DEEMPHASIS_EN = 1; TX_DEEPHASIS = 2'b00; USB_SSRX_VOD = 2'b00 (LINR_L3); Refer to Figure 6-7		-1.8		dB
V _{SSRX-DE-RATIO1}	SSRX de-emphasis when configured for limited redriver and de-emphasis enabled.	TX_PRESHOOT_EN = 0; TX_DEEMPHASIS_EN = 1; TX_DEEPHASIS = 2'b01; USB_SSRX_VOD = 2'b00 (LINR_L3); Refer to Figure 6-7		-2.1		dB
V _{SSRX-DE-RATIO2}	SSRX de-emphasis when configured for limited redriver and de-emphasis enabled.	TX_PRESHOOT_EN = 0; TX_DEEMPHASIS_EN = 1; TX_DEEPHASIS = 2'b10; USB_SSRX_VOD = 2'b00 (LINR_L3); Refer to Figure 6-7		-3.2		dB
V _{SSRX-DE-RATIO3}	SSRX de-emphasis when configured for limited redriver and de-emphasis enabled.	TX_PRESHOOT_EN = 0; TX_DEEMPHASIS_EN = 1; TX_DEEPHASIS = 2'b11; USB_SSRX_VOD = 2'b00 (LINR_L3); Refer to Figure 6-7		-3.8		dB
V _{SSRX-PRESH-RATIO0}	SSRX pre-shoot level when configured for limited redriver and pre-shoot enabled.	TX_PRESHOOT_EN = 1; TX_DEEMPHASIS_EN = 0; TX_PRESHOOT = 2'b00; USB_SSRX_VOD = 2'b00 (LINR_L3); Refer to Figure 6-6		1.6		dB
V _{SSRX-PRESH-RATIO1}	SSRX pre-shoot level when configured for limited redriver and pre-shoot enabled.	TX_PRESHOOT_EN = 1; TX_DEEMPHASIS_EN = 0; TX_PRESHOOT = 2'b01; USB_SSRX_VOD = 2'b00 (LINR_L3); Refer to Figure 6-6		2.1		dB
V _{SSRX-PRESH-RATIO2}	SSRX pre-shoot level when configured for limited redriver and pre-shoot enabled.	TX_PRESHOOT_EN = 1; TX_DEEMPHASIS_EN = 0; TX_PRESHOOT = 2'b10; USB_SSRX_VOD = 2'b00 (LINR_L3); Refer to Figure 6-6		2.5		dB
V _{SSRX-PRESH-RATIO3}	SSRX pre-shoot level when configured for limited redriver and pre-shoot enabled.	TX_PRESHOOT_EN = 1; TX_DEEMPHASIS_EN = 0; TX_PRESHOOT = 2'b11; USB_SSRX_VOD = 2'b00 (LINR_L3); Refer to Figure 6-6		3.0		dB
I _{TX(SHORT)}	TX short circuit current	TX± shorted to GND			60	mA
C _{TX(PARASITIC)}	TX input capacitance for return loss	At package pins, at 5 GHz			1.25	pF
R _{LTX(DIFF)}	Differential return loss	50 MHz – 1.25 GHz at 85 Ω		-28		dB
R _{LTX(CM)}	Common-mode return loss	50 MHz – 5 GHz at 85 Ω		-12		dB
C _{TX-AC(COUPLING)}	External required AC coupling capacitor		75		265	nF
AC Characteristics						
Crosstalk_CRXTX	Differential crosstalk between CTX1/2 and CRX1/2 signal pairs	85 Ω; At 5 GHz; SSEQ[1:0] = 0; CEQ[1:0] = 0;			-40	dB

5.7 USB Electrical Characteristics (continued)

over operating free-air temperature and voltage range (unless otherwise noted)

PARAMETER		TEST CONDITIONS	MIN	TYP	MAX	UNIT
CP _{LF-LINRL0}	Low-frequency -1dB compression point at LINR_L0 setting.	20 MHz clock pattern; VID is 200 mV to 1200 mV in 10 mV steps;		750		mVpp
CP _{HF-LINRL0}	High-frequency -1dB compression point at LINR_L0 setting.	5 GHz clock pattern; VID is 200mV to 1200mV in 10mV steps;		650		mVpp
CP _{LF-LINRL1}	Low-frequency -1dB compression point at LINR_L1 setting.	20 MHz clock pattern; VID is 200 mV to 1200 mV in 10 mV steps;		850		mVpp
CP _{HF-LINRL1}	High-frequency -1dB compression point at LINR_L1 setting.	5 GHz clock pattern; VID is 200 mV to 1200 mV in 10 mV steps;		750		mVpp
CP _{LF-LINRL2}	Low-frequency -1dB compression point at LINR_L2 setting.	20 MHz clock pattern; VID is 200 mV to 1200 mV in 10 mV steps;		950		mVpp
CP _{HF-LINRL2}	High-frequency -1dB compression point at LINR_L2 setting.	5 GHz clock pattern; VID is 200 mV to 1200 mV in 10 mV steps;		850		mVpp
CP _{LF-LINRL3}	Low-frequency -1dB compression point at LINR_L3 setting.	20 MHz clock pattern; VID is 200 mV to 1200 mV in 10mV steps;		1050		mVpp
CP _{HF-LINRL3}	High-frequency -1dB compression point at LINR_L3 setting.	5 GHz clock pattern; VID is 200 mV to 1200 mV in 10 mV steps;		900		mVpp
f _{LF}	Low frequency cutoff	200 mV _{PP} < V _{ID} < 1200 mV _{PP}		20	50	kHz
t _{TX_DJ_SSTX2-CTX2}	TX output deterministic residual jitter SSTX2-> CTX2.	Optimal EQ setting; 12-in prechannel (SDD21 = -11.2 dB); 1.6-in post channel (SDD21 = -1.8 dB); PRBS7; 10 Gbps		.05		UI
t _{TX_DJ_SSTX1-CTX1}	TX output deterministic residual jitter SSTX1-> CTX1.	Optimal EQ setting; 12-in prechannel (SDD21 = -11.2 dB); 1.6-in post channel (SDD21 = -1.8 dB); PRBS7; 10 Gbps		.05		UI

5.8 Timing Requirements

			MIN	NOM	MAX	UNIT
USB3.1						
t _{DLEEntry}	Delay from U0 to electrical idle	Refer to Figure 6-4 .			10	ns
t _{DELExit_U1}	U1 exit time: break in electrical idle to the transmission of LFPS	Refer to Figure 6-4 .			1	ns
t _{DLEExit_U2U3}	U2/U3 exit time: break in electrical idle to transmission of LFPS	Refer to Figure 6-4 .		10		μs
t _{RXDET_INTVL}	RX detect interval while in Disconnect				12	ms
t _{DLEExit_DISC}	Disconnect Exit Time			10		μs
t _{Exit_SHTDN}	Shutdown Exit Time				0.75	ms
t _{AEQ_FULL_DONE}	Maximum time to obtain optimum EQ setting when operating in Full AEQ mode.				400	μs
t _{AEQ_FAST_DONE}	Maximum time to determine appropriate EQ setting when operating in Fast AEQ mode.				60	μs
t _{DIFF_DLY}	Differential Propagation Delay	Refer to Figure 6-3 .			300	ps
t _R , t _F	Output Rise/Fall time	20%-80% of differential voltage measured 1.7 inch from the output pin; Refer to Figure 6-5 .	30			ps
t _{RF_MM}	Output Rise/Fall time mismatch	20%-80% of differential voltage measured 1.7 inch from the output pin			2.6	ps
Power-up						
t _{EN_LOW}	EN pin held low after supply reaches VCC(min)	Refer to Figure 6-1	5			ms
t _{CFG_SU}	CFG ⁽¹⁾ high	Refer to Figure 6-1	250			μs
t _{CFG_HD}	CFG ⁽¹⁾ high	Refer to Figure 6-1	500			μs

(1) Following pins comprise CFG pins: MODE, CEQ[1:0], SSEQ[1:0], EQCFG, AEQCFG

5.9 Switching Characteristics

over operating free-air temperature range (unless otherwise noted)

PARAMETER		TEST CONDITIONS	MIN	TYP	MAX	UNIT
I²C						
f _{SCL}	I ² C clock frequency				1	MHz
t _{BUF}	Bus free time between START and STOP conditions	Refer to Figure 6-2	0.5			μs
t _{HD_STA}	Hold time after repeated START condition. After this period, the first clock pulse is generated	Refer to Figure 6-2	0.26			μs
t _{LOW}	Low period of the I ² C clock	Refer to Figure 6-2	0.5			μs
t _{HIGH}	High period of the I ² C clock	Refer to Figure 6-2	0.26			μs
t _{SU_STA}	Setup time for a repeated START condition	Refer to Figure 6-2	0.26			μs
t _{HD_DAT}	Data hold time	Refer to Figure 6-2	0			μs
t _{SU_DAT}	Data setup time	Refer to Figure 6-2	50			ns
t _R	Rise time of both SDA and SCL signals	Refer to Figure 6-2			120	ns
t _F	Fall time of both SDA and SCL signals	Refer to Figure 6-2	20 × (V _{I2C} /5.5 V)		120	ns
t _{SU_STO}	Setup time for STOP condition	Refer to Figure 6-2	0.26			μs
C _b	Capacitive load for each bus line				150	pF

5.10 Typical Characteristics

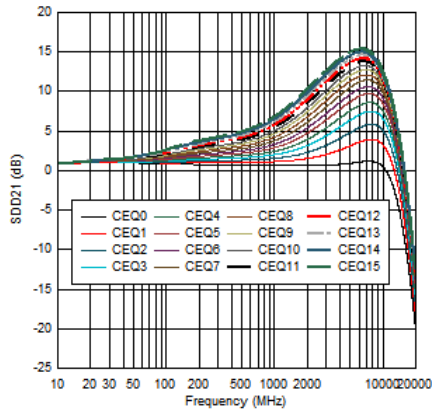

Figure 5-1. USB CRX1 EQ Settings Curves at 85 Ω (from simulation)

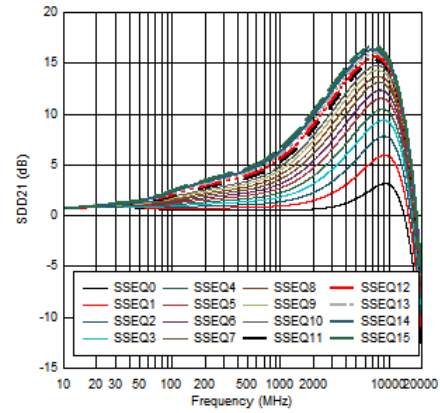

Figure 5-2. USB SSTX1 EQ Settings Curves at 85 Ω (from simulation)

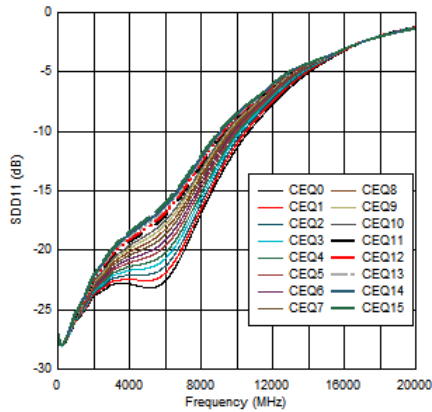

Figure 5-3. CRX1 Input Return Loss Performance at 85 Ω (from simulation)

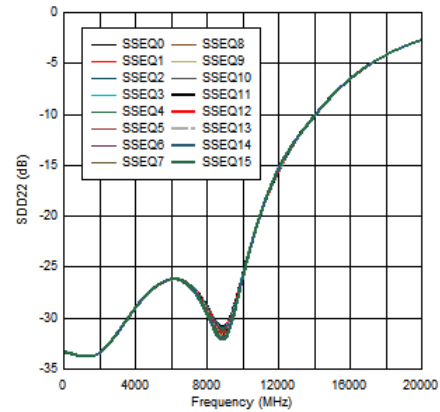

Figure 5-4. CTX1 Output Return Loss Performance at 85 Ω (from simulation)

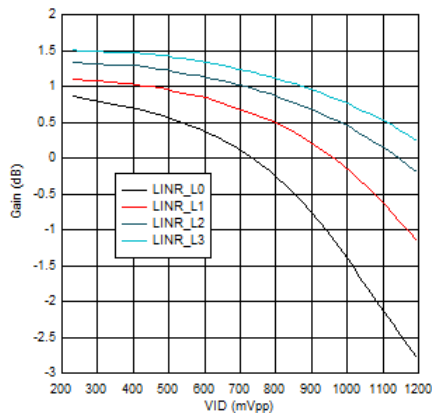

Figure 5-5. USB SSRX1 VOD Linearity Settings at 20 MHz and EQ = 0

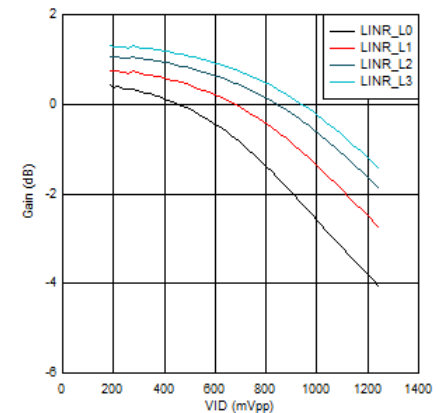

Figure 5-6. USB SSRX1 VOD Linearity Settings at 5 GHz and EQ = 0

5.10 Typical Characteristics (continued)

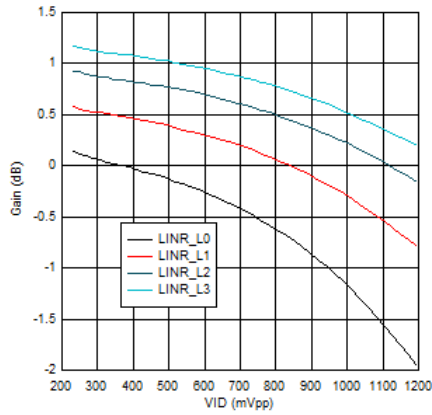

Figure 5-7. USB CTX1 VOD Linearity Settings at 20 MHz and EQ = 0

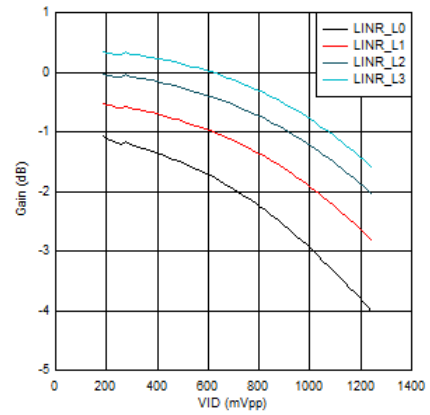

Figure 5-8. USB CTX1 VOD Linearity Settings at 5 GHz and EQ = 0

6 Parameter Measurement Information

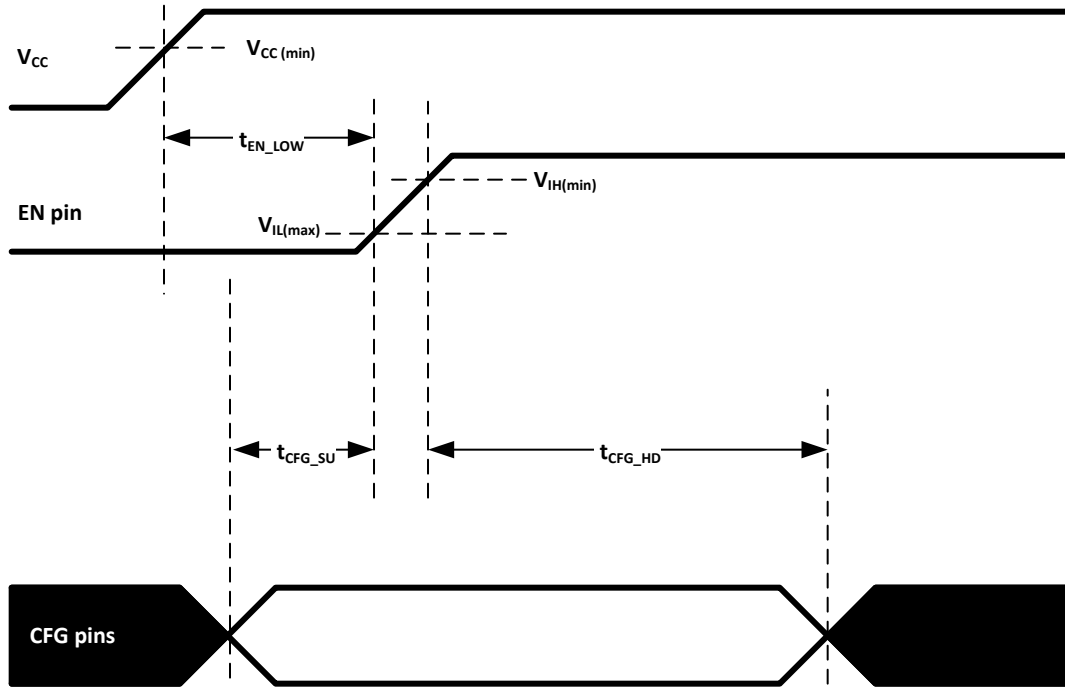

Figure 6-1. Power-On Timing Requirements

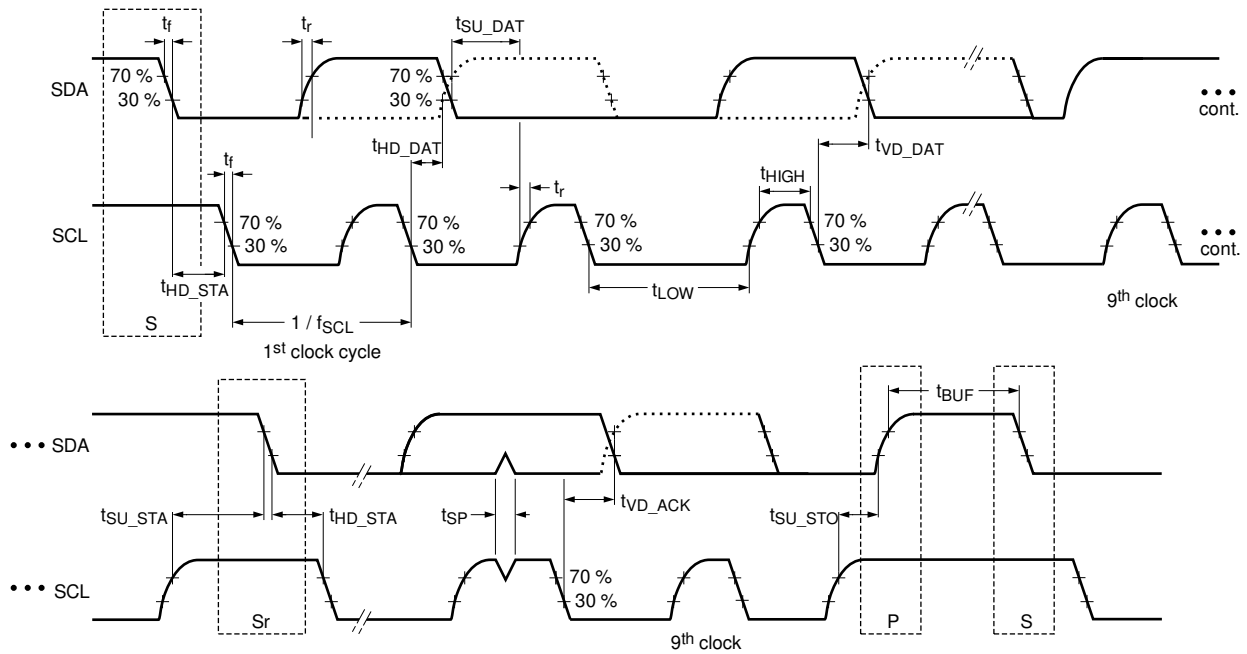

Figure 6-2. I2C Timing Diagram Definitions

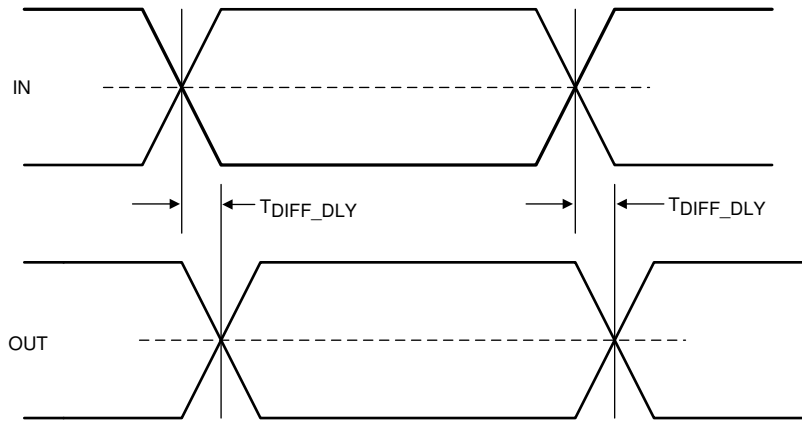

Figure 6-3. USB Propagation Delay

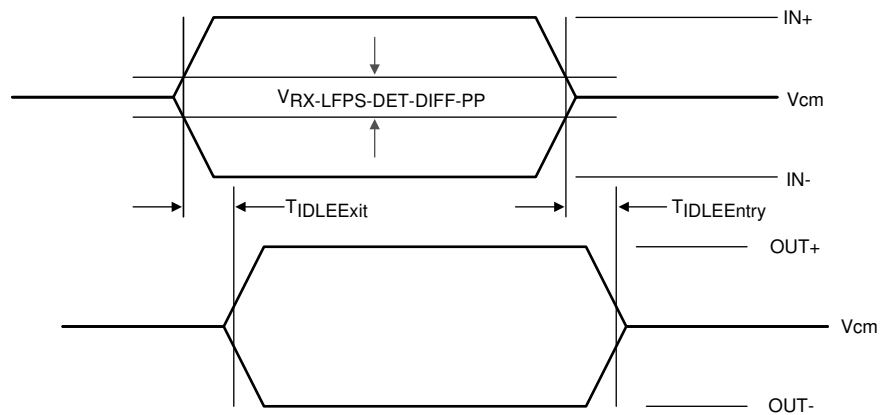

Figure 6-4. Electrical Idle Exit and Entry Delay

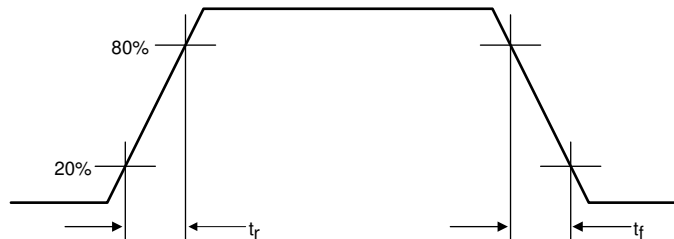

Figure 6-5. Output Rise and Fall Times

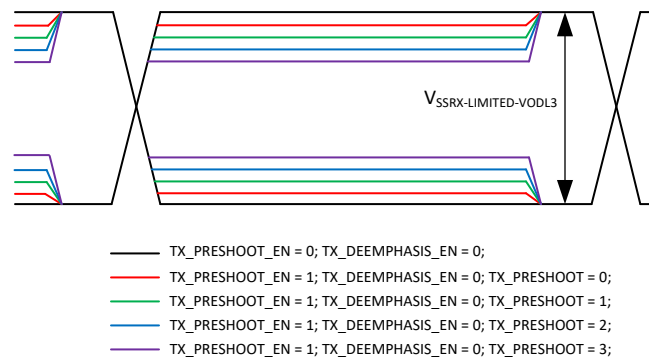

Figure 6-6. SSRX Limited Pre-Shoot only

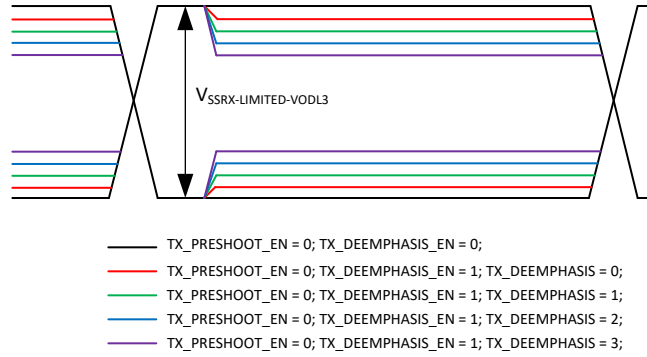

Figure 6-7. SSRX Limited De-Emphasis Only

7 Detailed Description

7.1 Overview

The TUSB1104 is a 10 Gbps USB 3.2 x2 linear redriver for USB-C applications enabling up to 20 Gbps total data throughput. The TUSB1104 supports both USB 3.2 Gen2 (10 Gbps) and Gen1 (5 Gbps) as well as USB 3.2 low power states (Disconnect, U1, U2, and U3). The TUSB1104 is intended to reside between a Host and a USB-C receptacle or between a USB device and a USB-C receptacle. The TUSB1104 will automatically detect whether or not the interface is operating at USB 3.2 x2 or x1. If it determines the USB interface is operating at USB 3.2 x1, then it will disable the unused lane to conserve power.

The TUSB1104 supports up to 16 receiver equalization settings controlled by either pin-strap pins or through I2C registers. The USB connector facing receivers (CRX1 and CRX2) support three equalization modes: Fixed EQ, Fast AEQ, and Full AEQ. Selection between these modes is done through either pin-strap pins or through I2C registers. The other receivers (SSTX1/2) only support Fixed EQ.

The TUSB1104 operates as a linear redriver for signals traversing from the SSTX1/2 receivers towards CTX1/2 transmitters. It can operate as either a linear redriver or limited redriver for signals traversing from CRX1/2 receivers towards SSRX1/2 transmitters. TUSB1104 defaults to linear redriver but can be enabled for limited redriver by I2C register. When enabled for limited redriver, the SSRX1/2 transmitter support four levels of pre-shoot and four-levels of de-emphasis.

7.2 Functional Block Diagram

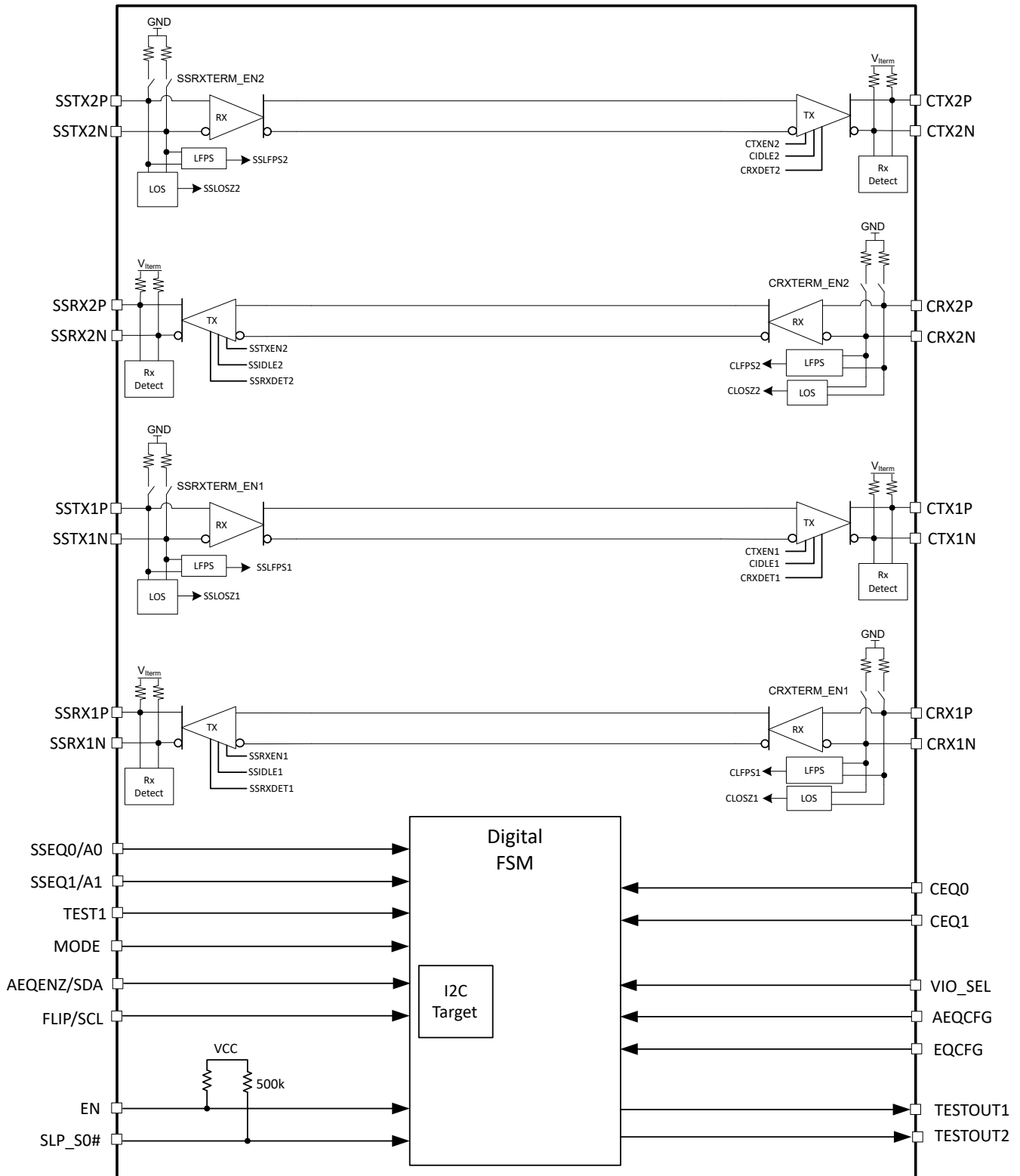

7.3 Feature Description

7.3.1 4-Level Inputs

The TUSB1104 has 4-level inputs pins that are used to control the receiver equalization gain, transmitter voltage swing, and place TUSB1104 into different modes of operation. These 4-level inputs utilize a resistor divider to help set the 4 valid levels and provide a wider range of control settings. There are internal pull-up and pull-down resistors. These resistors, together with the external resistor connection combine to achieve the desired voltage level.

Table 7-1. 4-Level Control Pin Settings

LEVEL	SETTINGS
0	Tie 1-k Ω 5% to GND.
R	Tie 20-k Ω 5% to GND.
F	Float (leave pin open)
1	Tie 1-k Ω 5% to V _{CC} .

Note

All 4-level inputs are latched after the rising edge of EN pin. After these pins are sampled, the internal pull-up and pull-down resistors will be isolated in order to save power.

7.3.2 USB Receiver Linear Equalization

The purpose of receiver equalization is to compensate for channel insertion loss and inter-symbol interference in the system before the input of the TUSB1104. The receiver overcomes these losses by attenuating the low frequency components of the signals with respect to the high frequency components. The proper gain setting should be selected to match the channel insertion loss before the input of the TUSB1104 receivers. Two 4-level inputs pins enable up to 16 possible equalization settings when in pin-strap mode. The TUSB1104's USB 3.2 host, hub, and device receivers (SSTX1/2) and USB 3.2 USB connector receivers (CRX1/2) each have their own two 4-level inputs. The TUSB1104 also provides the flexibility of adjusting settings through I²C registers.

The TUSB1104's USB host, hub, and device facing port receiver (SSTX1/2) only support Fixed EQ (FEQ). The TUSB1104 implements three different equalizer features for the USB connector facing port receivers (CRX1 and CRX2): Fixed EQ (FEQ), Fast Adaptive EQ (Fast AEQ), and Full Adaptive EQ (Full AEQ). In Fixed EQ operation, a single setting is used for all possible devices (with and without cable) inserted into the USB receptacle. The Fast AEQ feature will distinguish between a short channel and a long channel. A short channel represents a low loss use case of a USB 3.2 device plugged directly into USB receptacle without a cable. A long channel represents the high loss use case of the USB 3.2 device plugged into the receptacle through a USB cable. In Fast AEQ mode, TUSB1104 will select between two pre-determined settings based on whether or not channel is short or long. When TUSB1104 is configured for Full AEQ, the TUSB1104 will automatically determine what it believes is the best equalization setting each time a USB device is inserted into the USB receptacle. In Full AEQ mode, the TUSB1104 will attempt to determine the best settings regardless if the channel is short, long, or somewhere in between.

Note

Adaptive EQ is only supported on CRX1 and CRX2. Adaptive EQ must only be used when CRX1 and CRX2 is connected to a USB receptacle. If CRX1 and CRX2 is connected directly (not through a USB receptacle) to a USB Host, USB Hub or USB Device, then adaptive EQ must be disabled. AEQ should never be enabled in a active cable application. If daisy chaining multiple TUSB1104, AEQ should only be enabled on the TUSB1104 that is near the USB receptacle.

7.3.2.1 Linear EQ Configuration

Each of the TUSB1104 receiver lanes have individual controls for receiver equalization. The receiver equalization gain value can be controlled either through I²C registers or through pin-straps. [Table 7-2](#) and [Table 7-3](#) details the gain value for each available combination when TUSB1104 is in pin-strap mode. These same options are also available in I²C mode by updating registers CEQ1_SEL, CEQ2_SEL, SSEQ2_SEL, and SSEQ1_SEL.

Table 7-2. USB Connector Facing Port Receiver (CRX1 and CRX2 pins) Equalization Control

Register(s): CEQ1_SEL or CEQ2_SEL Equalization Setting #	CEQ1 PIN Level	CEQ0 PIN Level	EQ Gain at 5 GHz minus Gain at 100 MHz (dB)
0	0	0	-0.4
1	0	R	1.9
2	0	F	3.5
3	0	1	5.0
4	R	0	6.1
5	R	R	7.2
6	R	F	8.0
7	R	1	8.8
8	F	0	9.6
9	F	R	10.2
10	F	F	10.7
11	F	1	11.2
12	1	0	11.6
13	1	R	12.0
14	1	F	12.4
15	1	1	12.7

Table 7-3. USB Host Facing Port Receiver (SSTX1 and SSTX2 pins) Equalization Control

Register(s): SSEQ1_SEL or SSEQ2_SEL Equalization Setting #	SSEQ1 PIN LEVEL	SSEQ0 PIN LEVEL	EQ Gain at 5 GHz minus Gain at 100 MHz (dB)
0	0	0	0.6
1	0	R	2.8
2	0	F	4.5
3	0	1	6.0
4	R	0	7.0
5	R	R	8.0
6	R	F	9.0
7	R	1	10.0
8	F	0	10.6
9	F	R	11.2
10	F	F	11.7
11	F	1	12.2
12	1	0	12.5
13	1	R	13.0
14	1	F	13.3
15	1	1	13.6

7.3.2.2 Full Adaptive Equalization

The Full AEQ mode attempts to find what it believes is the best equalization value for CRX1 and CRX2 receivers by starting at the lowest EQ value and sweeping through all EQ combinations up to the value programmed into FULLAEQ_UPPER_EQ field. The default is to sweep through nine EQ values (zero to eight). The number of EQ combinations can be adjusted by programming FULLAEQ_UPPER_EQ register. The TUSB1104 also provides the ability to add or subtract some over/under equalization to compensate for channel in front of TUSB1104 by programming OVER_EQ_CTRL field to a non-zero value. If OVER_EQ_SIGN = 0, the TUSB1104 will add the value programmed into OVER_EQ_CTRL to the EQ value determined by the full adaptation. If OVER_EQ_SIGN = 1, the TUSB1104 will subtract the value programmed into OVER_EQ_CTRL from the EQ value determined by the full adaptation. For example, if full adaptation determines the best equalization value to be 4 and OVER_EQ_CTRL is 2 and OVER_EQ_SIGN = 0, the EQ setting used by TUSB1104 will be 6. The TUSB1104 hardware will always limit the sum of OVER_EQ_CTRL and the determined optimal EQ from full adaptation to be less than or equal to 15.

Note

Full AEQ is supported in both pin-strap and I²C mode. In pin-strap mode, enable or disable of Full AEQ is determined by the state of AEQENZ pin.

7.3.2.3 Fast Adaptive Equalization

The Fast AEQ mode is used to distinguish two channels (short channel and a long channel) and choose the appropriate receiver equalization setting for that channel. Because Fast AEQ only distinguishes between two choices, the AEQ time is a lot shorter than Full AEQ mode which minimizes impact to USB link training.

When Fast AEQ is enabled and channel is determined to be short, the TUSB1104 will use the value programmed into the CEQx_SEL, where x = 1 or 2. If the TUSB1104 determines channel is not short, the TUSB1104 will switch to EQ value programmed into LONG_EQx register, where x = 1 or 2. During initial system evaluation, it is recommended to perform both short and long channel USB 3.1 RX JTOL Gen2 testing and program CEQx_SEL and LONG_EQx to the value which produced the best results for each channel configuration.

The TUSB1104 will determine short and long based on the estimate eye height. The value programmed into FASTAEQ_LIMITS register will determine the eye height limits. Software can change the defaults of this register to lower or raise the limits.

Note

Fast AEQ is only supported in I²C mode.

EQ_OVERRIDE field must be set for values programmed into CEQx_SEL and LONG_EQx to be used.

7.3.3 USB Transmitter

7.3.3.1 Linearity VOD

Linearity VOD defines the linearity range of the TUSB1104. When TUSB1104 is in linear VOD mode, the output VOD is a linear function of the input VID. For example, if the signal at TUSB1104's input (VID) is at 600 mVpp then the TUSB1104's output VOD will be around 600 mVpp. Linearity VOD mode is the default operation of the TUSB1104. Linear VOD mode is supported on SSRX1/2 and CTX1/2 transmitters.

The TUSB1104 provides four different linearity VOD settings. All four settings are available in I²C mode through register control. In pin-strap mode, the linearity is fixed at the highest setting.

7.3.3.2 Limited VOD

Limited VOD mode is used to set the actual VOD level and is used when TUSB1104 is configured in limited redriver mode. In this mode the VOD is no longer a linear function of the input VID. For example, if the signal at TUSB1104's input (VID) is at 600 mVpp then the TUSB1104's output VOD will be around 1000 mVpp (assuming LINR_L3 is selected). The limited redriver mode is only supported on the SSRX1/2 transmitter. The TUSB1104 provides four different limited VOD settings. All four settings are available through register control.

Note

Limited redriver mode is disabled by default and can only be enabled by setting the SSRX_LIMIT_ENABLE register. Once enabled, the VOD level for SSRX1/2 transmitters is controlled by the USB_SSRX12_VOD register

7.3.3.3 Transmit Equalization (Limited Redriver Mode Only)

The TUSB1104 in limited redriver mode offers pre-shoot and de-emphasis controls for SSRX1/2 transmitter. The TUSB1104 offers four pre-shoot levels and four de-emphasis levels. These levels can be changed by modifying I²C registers.

SSRX1 transmitter equalization is controlled by TX1_PRESHOOT and TX1_DEEMPHASIS fields. When SSRX_LIMIT_ENABLE = 1 and TX1_PRESHOOT_EN = 1, the TX1_PRESHOOT field selects between four different pre-shoot levels. When SSRX_LIMIT_ENABLE = 1 and TX1_DEEMPHASIS_EN = 1, the TX1_DEEMPHASIS field selects between four different de-emphasis levels.

SSRX2 transmitter equalization is controlled by TX2_PRESHOOT and TX2_DEEMPHASIS fields. When SSRX_LIMIT_ENABLE = 1 and TX2_PRESHOOT_EN = 1, the TX2_PRESHOOT field selects between four different pre-shoot levels. When SSRX_LIMIT_ENABLE = 1 and TX2_DEEMPHASIS_EN = 1, the TX2_DEEMPHASIS field selects between four different de-emphasis levels.

Note

Transmitter equalization control is not supported in pin-strap mode.

7.3.4 USB 3.2 x2 Description

The TUSB1104 configured for USB 3.2 x2 mode will determine if the link is operating in USB 3.2 x2 or in USB 3.1 x1. If the link is USB 3.2 x2, then TUSB1104 will operate with one port operating as a USB 3.2 x1 port and the remaining port following the lead of the other port. The port functioning as a USB 3.1 x1 port is called the config lane. The determination of the config lane is based solely on the Type-C orientation. For normal orientation (FLIP = L), Port 1 is the config lane. For the flipped orientation (FLIP = H), Port 2 is the config lane.

In USB 3.2 x2 the config lane will operate as a standard USB 3.2 x1 port. While in all USB low power states (Disconnect, U1, U2, and U3), the non-config lane will be disabled in order to conserve power. Entry to and exit from these low power states is determined solely by the config lane. If the config lane detects an exit from a low power state, then the non-config will be enabled.

Table 7-4. Config Lane Selection

FLIP pin or FLIP_SEL register	CONFIG LANE	NON-CONFIG LANE
0	CRX1 -> SSRX1	CRX2 -> SSRX2
	SSTX1 -> CTX1	SSTX2 -> CTX2
1	CRX2 -> SSRX2	CRX1 -> SSRX1
	SSTX2 -> CTX2	SSTX1 -> CTX1

7.3.5 USB Polarity Inversion

The USB 3.2 standard requires all host, hubs, and devices support USB polarity inversion detection and correction. For this reason, polarity between TUSB1104 and USB connector as well as between USB Host/Device and TUSB1104 does not have to be maintained. Not maintaining polarity will simplify layout by eliminating the need to swap P and N in the layout. The [Figure 7-1](#) shows example in which polarity between USB host and redriver is not maintained.

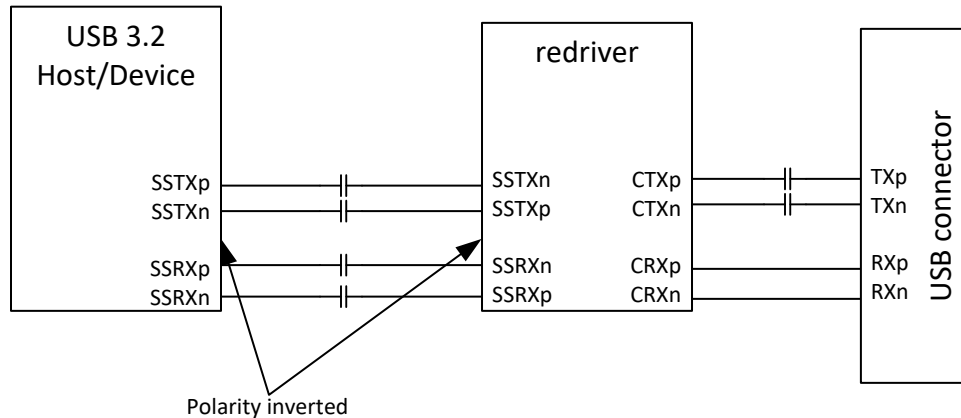

Figure 7-1. Polarity Inversion Example

7.3.6 Receiver Detect Control

The SLP_S0# pin offers system designers the ability to control the TUSB1104 Rx.Detect functionality during Disconnect and U2/U3 states and therefore achieving lower consumption in these states. When the system is in a low power state (Sx where x = 1, 2, 3, 4, or 5), system can assert SLP_S0# low to disable TUSB1104 receiver detect functionality. While SLP_S0# is asserted low and USB 3.2 interface is in U3, the TUSB1104 keeps receiver termination active. The TUSB1104 will not respond to any LFPS signaling while in this state. This means that system wake from U3 is not supported while SLP_S0# is asserted low. If the TUSB1104 is in Disconnect state when SLP_S0# is asserted low, then TUSB1104 disables all channels receiver termination and disables receiver detect functionality. When SLP_S0# is asserted high, the TUSB1104 resumes normal operation of performing far-end receiver termination detection.

Note

As there is a single SLP_S0# pin, this pin when asserted low impact both port 1 (CRX1, CTX1, SSRX1, SSTX1) and port 2 (CRX2, CTX2, SSRX2, SSTX2).

7.4 Device Functional Modes

7.4.1 MODE Pin

The MODE pin selects between between I²C mode and pin-strap mode. Refer to [Table 7-5](#) for details.

In I²C mode, the TUSB1104 supports either 1.8-V LVCMOS or 3.3-V LVCMOS signalling based on the sampled state of VIO_SEL pin.

Table 7-5. MODE pin Function

MODE pin level	Description
0	Reserved.
R	Reserved
F	I ² C Mode
1	Pin-strap mode.

7.4.2 Rx EQ Configuration in Pin-Strap Mode

The TUSB1104 configured in pin-strap mode uses the follow pins to control the EQ setting for each of its receivers: EQCFG pin, SSEQ[1:0] pins, CEQ[1:0] pins.

Table 7-6. Pin-strap: SSTX1 and SSTX2 Receiver EQ Configuration

SSTX Receiver	SSEQ[1:0] pin level	Gain at 5 GHz	EQCFG pin level
SSTX1	SSEQ0 = "0"	3 dB	"1" or "R"
	SSEQ0 = "R"	6 dB	"1" or "R"
	SSEQ0 = "F"	9 dB	"1" or "R"
	SSEQ0 = "1"	12 dB	"1" or "R"
	16 possible settings based on SSEQ0 and SSEQ1	Refer to Table 7-3 .	"0" or "F"
SSTX2	SSEQ1 = "0"	3 dB	"1" or "R"
	SSEQ1 = "R"	6 dB	"1" or "R"
	SSEQ1 = "F"	9 dB	"1" or "R"
	SSEQ1 = "1"	12 dB	"1" or "R"
	16 possible settings based on SSEQ0 and SSEQ1	Refer to Table 7-3 .	"0" or "F"

The following table describes receiver equalization controls for the receivers facing the USB connector.

Table 7-7. Pin Strap: CRX1 and CRX2 EQ Configuration with AEQ Disabled

CRX Receiver	CEQ[1:0] pin level	Gain at 5 GHz	EQCFG pin level
CRX1	CEQ0 = "0"	3 dB	"0" or "R"
	CEQ0 = "R"	6 dB	"0" or "R"
	CEQ0 = "F"	9 dB	"0" or "R"
	CEQ0 = "1"	12 dB	"0" or "R"
	16 possible settings based on CEQ0 and CEQ1	Refer to Table 7-2 .	"F" or "1"
CRX2	CEQ1 = "0"	3 dB	"0" or "R"
	CEQ1 = "R"	6 dB	"0" or "R"
	CEQ1 = "F"	9 dB	"0" or "R"
	CEQ1 = "1"	12 dB	"0" or "R"
	16 possible settings based on CEQ0 and CEQ1	Refer to Table 7-2 .	"F" or "1"

7.4.3 USB 3.2 Power States

The TUSB1104 monitors the physical layer conditions like receiver termination, electrical idle, LFPS, and SuperSpeed signaling rate to determine the state of the USB 3.1 interface. Depending on the state of the USB 3.2 interface, the TUSB1104 can be in one of four primary modes of operation when USB 3.1 is enabled: Disconnect, U2/U3, U1, and U0 (Active).

The *Disconnect* state is the state in which TUSB1104 has not detected far-end termination on both upstream facing port (UFP) or downstream facing port (DFP). The disconnect mode is the lowest power mode of each of the four states. The TUSB1104 remains in this state until far-end receiver termination has been detected on both UFP (SSRX) and DFP (CTX). The TUSB1104 immediately exits this mode and enters U0 once far-end termination is detected.

Once in U0 state, the TUSB1104 will redrive all traffic received on the port in both directions. U0 is the highest power mode of all USB 3.2 power states. The TUSB1104 remains in U0 state until electrical idle occurs on both UFP and DFP. Upon detecting electrical idle, the TUSB1104 immediately transitions to U1.

The U1 state is the intermediate mode between U0 mode and U2/U3 mode. In U1 mode, the TUSB1104 UFP and DFP receiver termination remains enabled. The UFP and DFP transmitter DC common mode is maintained. The power consumption in U1 is similar to power consumption of U0.

Next to the disconnect state, the U2/U3 state is next lowest power state. While in this state, the TUSB1104 periodically performs far-end receiver detection. Anytime the far-end receiver termination is not detected on either UFP or DFP, the TUSB1104 leaves the U2/U3 state and transitions to the Disconnect state. It also monitors for a valid LFPS. Upon detection of a valid LFPS, the TUSB1104 immediately transitions to the U0 state. In U2/U3 state, the TUSB1104 receiver terminations remain enabled but the TX DC common mode voltage is not maintained.

7.4.4 Disabling U1 and U2

In systems which have U1 and U2 disabled, it may be necessary to disable U1 and U2 in TUSB1104. In I2C mode this can be accomplished by setting the USB3_U1_DISABLE field. In pin-strap mode U1 and U2 is enabled by default and can't be disabled.

7.5 Programming

7.5.1 Pseudocode Examples

7.5.1.1 Fixed EQ with Linear Redriver Mode

```
// (address, data)
// Initial power-on configuration.

(0x0A, 0x11), // Linear redriver, EQ_OVERRIDE and USB 3.2
(0x1C, 0x80), // Disable AEQ enable.
(0x32, 0xC0), // VOD control
(0x20, 0x44), // USB connector CRx1/CRx2 EQ setting

(0x21, 0x55), // SSTX1 and SSTX2 receiver EQ
```

```
// Controls when selecting between normal and flip orientation.
If (USBOnly_normal) // USB-C connected and normal orientation.
{ (0x0A, 0x11); }
Else if (USBOnly_flip) // USB-C connected and Flip orientation.
{ (0x0A, 0x15); }
Else // Nothing connected to USB-C connector. Disable USB 3.2.
{ (0x0A, 0x10); }
```

7.5.1.2 Fixed EQ with Limited Redriver Mode

```
// (address, data)
// Initial power-on configuration.

(0x0A, 0x91), // Limited redriver, EQ_OVERRIDE and USB 3.2

(0x0B, 0x6F), // SSRX1 limited. Preshoot and de-emphasis.
(0x0C, 0x6C), // SSRX2 limited. Preshoot and de-emphasis.
(0x1C, 0x80), // Disable AEQ enable.
(0x32, 0xC0), // VOD control
(0x20, 0x44), // USB connector CRx1/CRx2 EQ setting

(0x21, 0x55), // SSTX1 and SSTX2 receiver EQ
```

```
// Controls when selecting between normal and flip orientation.
If (USBonly_normal) // USB-C connected and normal orientation.
{ (0x0A, 0x91); }
Else if (USBonly_flip) // USB-C connected and Flip orientation.
{ (0x0A, 0x95); }
Else // Nothing connected to USB-C connector. Disable USB 3.2.
{ (0x0A, 0x90); }
```

7.5.1.3 Fast AEQ with Linear Redriver Mode

```
// (address, data)
// Initial power-on configuration.

(0x0A, 0x11), // Linear redriver, EQ_OVERRIDE and USB 3.2
(0x1C, 0x81), // Fast AEQ enable.
(0x32, 0xC0), // VOD control
(0x1D, 0x10), // Over EQ adjustment
(0x1E, 0x77), // USB connector CRx1/CRx2 long channel EQ setting
(0x20, 0x11), // USB connector CRx1/CRx2 short channel EQ setting

(0x21, 0x55), // SSTX1 and SSTX2 receiver EQ
```

```
// Controls when selecting between normal and flip orientation.
If (USBonly_normal) // USB-C connected and normal orientation.
{ (0x0A, 0x11); }
Else if (USBonly_flip) // USB-C connected and Flip orientation.
{ (0x0A, 0x15); }
Else // Nothing connected to USB-C connector. Disable USB 3.2.
{ (0x0A, 0x10); }
```

7.5.1.4 Fast AEQ with Limited Redriver Mode

```
// (address, data)
// Initial power-on configuration.

(0x0A, 0x91), // Limited redriver, EQ_OVERRIDE and USB 3.2

(0x0B, 0x6F), // SSRX1 limited. Preshoot and de-emphasis.
(0x0C, 0x6C), // SSRX2 limited. Preshoot and de-emphasis.
(0x32, 0xC0), // VOD control
(0x1C, 0x81), // Fast AEQ enable.
(0x1D, 0x10), // Over EQ adjustment
(0x1E, 0x77), // USB connector CRx1/CRx2 long channel EQ setting
(0x20, 0x11), // USB connector CRx1/CRx2 short channel EQ setting

(0x21, 0x55), // SSTX1 and SSTX2 receiver EQ
```

```
// Controls when selecting between normal and flip orientation.
If (USBOnly_normal) // USB-C connected and normal orientation.
{ (0x0A, 0x91); }
Else if (USBOnly_flip) // USB-C connected and Flip orientation.
{ (0x0A, 0x95); }
Else // Nothing connected to USB-C connector. Disable USB 3.2.
{ (0x0A, 0x90); }
```

7.5.1.5 Full AEQ with Linear Redriver Mode

```
// (address, data)
// Initial power-on configuration.

(0x0A, 0x11), // Linear redriver, EQ_OVERRIDE and USB 3.2
(0x32, 0xC0), // VOD control
(0x1C, 0x85), // Full AEQ enable. Set upper EQ limit to 0x8.
(0x1D, 0x10), // Over EQ adjustment
(0x20, 0x11), // USB connector CRx1/CRx2 EQ. Not used in Full AEQ.

(0x21, 0x55), // SSTX1 and SSTX2 receiver EQ
```

```
// Controls when selecting between normal and flip orientation.
If (USBOnly_normal) // USB-C connected and normal orientation.
{ (0x0A, 0x11); }
Else if (USBOnly_flip) // USB-C connected and Flip orientation.
{ (0x0A, 0x15); }
Else // Nothing connected to Type-C. Disable USB 3.2.
{ (0x0A, 0x10); }
```

7.5.1.6 Full AEQ with Limited Redriver Mode

```
// (address, data)
// Initial power-on configuration.

(0x0A, 0x91), // Limited redriver, EQ_OVERRIDE and USB 3.2

(0x0B, 0x6F), // SSRX1 limited. Preshoot and de-emphasis.
(0x0C, 0x6C), // SSRX2 limited. Preshoot and de-emphasis.
(0x32, 0xC0), // VOD control
(0x1C, 0x85), // Full AEQ enable.
(0x1D, 0x10), // Over EQ adjustment
(0x20, 0x11), // USB connector CRx1/CRx2 short channel EQ setting. Not used for Full AEQ.

(0x21, 0x55), // SSTX1 and SSTX2 receiver EQ
```

```
// Controls when selecting between normal and flip orientation.
If (USBonly_normal) // USB-C connected and normal orientation.
{ (0x0A, 0x91); }
Else if (USBonly_flip) // USB-C connected and Flip orientation.
{ (0x0A, 0x95); }
Else // Nothing connected to USB-C connector. Disable USB 3.2.
{ (0x0A, 0x90); }
```

7.5.2 TUSB1104 I²C Address Options

For further programmability, the TUSB1104 can be controlled using I²C. The SCL and SDA pins are used for I²C clock and I²C data respectively.

Table 7-8. TUSB1104 I²C Target Address

SSEQ1/A1 PIN LEVEL	SSEQ0/A0 PIN LEVEL	7-bit Address	Bit 7 (MSB)	Bit 6	Bit 5	Bit 4	Bit 3	Bit 2	Bit 1	Bit 0 (W/R)
0	0	44h	1	0	0	0	1	0	0	0/1
0	R	45h	1	0	0	0	1	0	1	0/1
0	F	46h	1	0	0	0	1	1	0	0/1
0	1	47h	1	0	0	0	1	1	1	0/1
R	0	20h	0	1	0	0	0	0	0	0/1
R	R	21h	0	1	0	0	0	0	1	0/1
R	F	22h	0	1	0	0	0	1	0	0/1
R	1	23h	0	1	0	0	0	1	1	0/1
F	0	10h	0	0	1	0	0	0	0	0/1
F	R	11h	0	0	1	0	0	0	1	0/1
F	F	12h	0	0	1	0	0	1	0	0/1
F	1	13h	0	0	1	0	0	1	1	0/1
1	0	Ch	0	0	0	1	1	0	0	0/1
1	R	Dh	0	0	0	1	1	0	1	0/1
1	F	Eh	0	0	0	1	1	1	0	0/1
1	1	Fh	0	0	0	1	1	1	1	0/1

7.5.3 TUSB1104 I²C Target Behavior

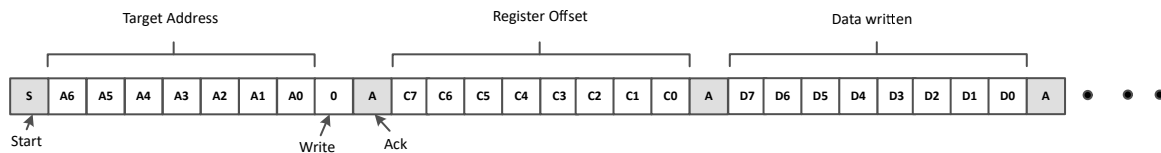

Figure 7-2. I2C Write with Data

The following procedure should be followed to write data to TUSB1104 I²C registers (refer to [Figure 7-2](#)):

1. The controller initiates a write operation by generating a start condition (S), followed by the TUSB1104 7-bit address and a zero-value “W/R” bit to indicate a write cycle.
2. The TUSB1104 acknowledges the address cycle.
3. The controller presents the register offset within TUSB1104 to be written, consisting of one byte of data, MSB-first.
4. The TUSB1104 acknowledges the sub-address cycle.
5. The controller presents the first byte of data to be written to the I²C register.
6. The TUSB1104 acknowledges the byte transfer.
7. The controller may continue presenting additional bytes of data to be written, with each byte transfer completing with an acknowledge from the TUSB1104.
8. The controller terminates the write operation by generating a stop condition (P).

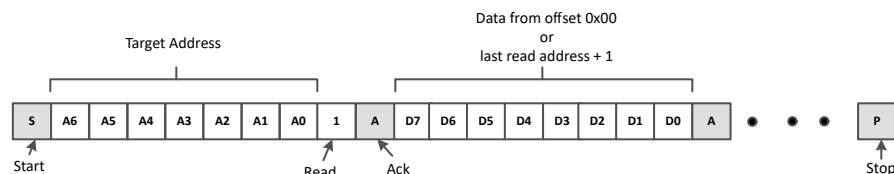

Figure 7-3. I2C Read Without Repeated Start

The following procedure should be followed to read the TUSB1104 I²C registers without a repeated Start (refer [Figure 7-3](#)).

1. The controller initiates a read operation by generating a start condition (S), followed by the TUSB1104 7-bit address and a zero-value “W/R” bit to indicate a read cycle.
2. The TUSB1104 acknowledges the 7-bit address cycle.
3. Following the acknowledge the controller continues sending clock.
4. The TUSB1104 transmit the contents of the memory registers MSB-first starting at register 00h or last read register offset+1. If a write to the I²C register occurred prior to the read, then the TUSB1104 shall start at the register offset specified in the write.
5. The TUSB1104 waits for either an acknowledge (ACK) or a not-acknowledge (NACK) from the controller after each byte transfer; the I²C controller acknowledges reception of each data byte transfer.
6. If an ACK is received, the TUSB1104 transmits the next byte of data as long as controller provides the clock. If a NAK is received, the TUSB1104 stops providing data and waits for a stop condition (P).
7. The controller terminates the write operation by generating a stop condition (P).

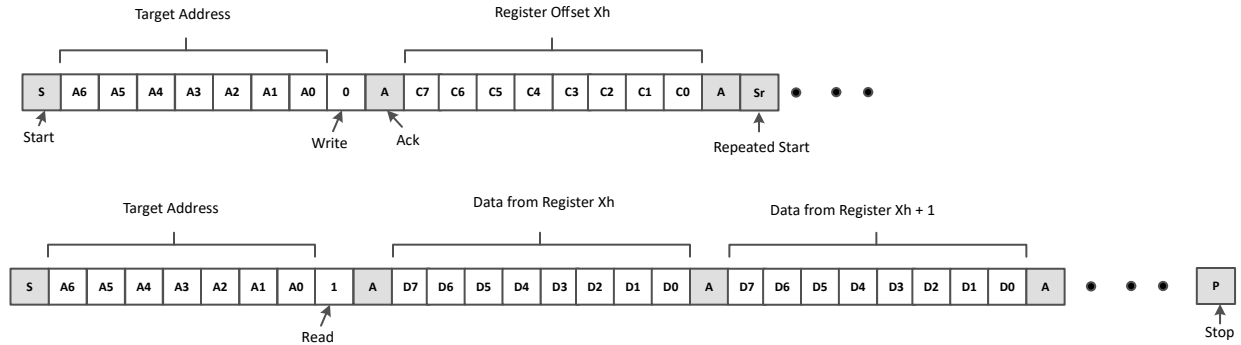

Figure 7-4. I2C Read with Repeated Start

The following procedure should be followed to read the TUSB1104 I²C registers with a repeated Start (refer [Figure 7-4](#)).

1. The controller initiates a read operation by generating a start condition (S), followed by the TUSB1104 7-bit address and a zero-value “W/R” bit to indicate a write cycle.
2. The TUSB1104 acknowledges the 7-bit address cycle.
3. The controller presents the register offset within TUSB1104 to be written, consisting of one byte of data, MSB-first.
4. The TUSB1104 acknowledges the register offset cycle.
5. The controller presents a repeated start condition (Sr).
6. The controller initiates a read operation by generating a start condition (S), followed by the TUSB1104 7-bit address and a one-value “W/R” bit to indicate a read cycle.
7. The TUSB1104 acknowledges the 7-bit address cycle.
8. The TUSB1104 transmit the contents of the memory registers MSB-first starting at the register offset.
9. The TUSB1104 shall wait for either an acknowledge (ACK) or a not-acknowledge (NACK) from the controller after each byte transfer; the I²C controller acknowledges reception of each data byte transfer.
10. If an ACK is received, the TUSB1104 transmits the next byte of data as long as controller provides the clock. If a NAK is received, the TUSB1104 stops providing data and waits for a stop condition (P).
11. The controller terminates the read operation by generating a stop condition (P).

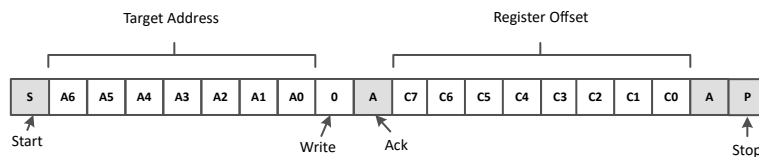

Figure 7-5. I2C Write Without Data

The following procedure should be followed for setting a starting sub-address for I²C reads (refer to [Figure 7-5](#)).

1. The controller initiates a write operation by generating a start condition (S), followed by the TUSB1104 7-bit address and a zero-value “W/R” bit to indicate a write cycle.
2. The TUSB1104 acknowledges the address cycle.
3. The controller presents the register offset within TUSB1104 to be written, consisting of one byte of data, MSB-first.
4. The TUSB1104 acknowledges the register offset cycle.
5. The controller terminates the write operation by generating a stop condition (P).

Note

After initial power-up, if no register offset is included for the read procedure (refer to [Figure 7-3](#)), then reads start at register offset 00h and continue byte by byte through the registers until the I²C controller terminates the read operation. During a read operation, the TUSB1104 auto-increments the I²C internal register address of the last byte transferred independent of whether or not an ACK was received from the I2C controller.

7.6 Register Map

7.6.1 Device Registers

[Table 7-9](#) lists the memory-mapped registers for the Device registers. All register offset addresses not listed in [Table 7-9](#) should be considered as reserved locations and the register contents should not be modified.

Table 7-9. DEVICE Registers

Offset	Acronym	Register Name	Section
8h	Rev_ID	Revision ID Register	Go
Ah	General_1	General Register	Go
Bh	TX1EQ_CTRL	TX1 EQ Control	Go
Ch	TX2EQ_CTRL	TX2 EQ Control	Go
1Ch	AEQ_CONTROL1	AEQ Controls	Go
1Dh	AEQ_CONTROL2	AEQ Controls	Go
1Eh	AEQ_LONG	AEQ setting for Long channel	Go
20h	USBC_EQ	EQ control for CRX1 and CRX2 receivers	Go
21h	SS_EQ	EQ Control for SSTX1 and SSTX2 receiver	Go
22h	USB3_MISC	Misc USB3 Controls	Go
24h	USB1_STATUS	USB1 state machine status	Go
25h	USB2_STATUS	USB2 state machine status	Go
32h	VOD_CTRL	VOD Linearity and AEQ Controls	Go
3Bh	AEQ1_STATUS	Full and Fast AEQ status	Go
3Ch	AEQ2_STATUS	Full and Fast AEQ status	Go
50h	AEQ_CONTROL_AUX1		Go
51h	AEQ_CONTROL_AUX2		Go
52h	AEQ_CONTROL_AUX3		Go

Complex bit access types are encoded to fit into small table cells. [Table 7-10](#) shows the codes that are used for access types in this section.

Table 7-10. Device Access Type Codes

Access Type	Code	Description
Read Type		
H	H	Set or cleared by hardware
R	R	Read
RH	R H	Read Set or cleared by hardware
Write Type		
W	W	Write
W1C	W 1C	Write 1 to clear
W1S	W 1S	Write 1 to set

Table 7-10. Device Access Type Codes (continued)

Access Type	Code	Description
WtoP	W	Write
Reset or Default Value		
-n		Value after reset or the default value

7.6.1.1 Rev_ID Register (Offset = 8h) [Reset = 01h]

Rev_ID is shown in [Table 7-11](#).

Return to the [Summary Table](#).

Table 7-11. Rev_ID Register Field Descriptions

Bit	Field	Type	Reset	Description
7-0	REVISION_ID	RH	1h	Device Revision

7.6.1.2 General_1 Register (Offset = Ah) [Reset = 00h]

General_1 is shown in [Table 7-12](#).

Return to the [Summary Table](#).

This register is used to enable USB as well as selecting the orientation to indicate config lane. Software should set EQ_OVERRIDE bit in order for EQ registers to be used instead of pins.

Table 7-12. General_1 Register Field Descriptions

Bit	Field	Type	Reset	Description
7	SSRX_LIMIT_ENABLE	R/W	0h	Limited redriver mode enable for SSRX transmitter. 0h = Linear Redriver 1h = Limited Redriver
6	RESERVED	R	0h	Reserved
5	RESERVED	R	0h	Reserved
4	EQ_OVERRIDE	R/W	0h	Setting this field will allow software to use EQ settings from registers instead of value sampled from pins. 0h = EQ settings based on sampled state of EQ pins. 1h = EQ settings based on programmed value of each of the EQ registers.
3	RESERVED	R	0h	Reserved
2	FLIP_SEL	R/W	0h	This field controls the orientation. 0h = Normal Orientation 1h = Flip orientation.
1-0	CTLSEL	R/W	0h	Controls whether USB is enabled or not. 0h = Disabled 1h = USB enabled. 2h = Disabled 3h = USB enabled

7.6.1.3 TX1EQ_CTRL Register (Offset = Bh) [Reset = 6Fh]

TX1EQ_CTRL is shown in [Table 7-13](#).

Return to the [Summary Table](#).

This register controls the pre-shoot and de-emphasis levels for SSRX1 when limited redriver mode is enabled.

Table 7-13. TX1EQ_CTRL Register Field Descriptions

Bit	Field	Type	Reset	Description
7-6	SSRX1_PRESHOOT	R/W	1h	SSRX1 TX preshoot level (pre-cursor). 0h = 1.5dB 1h = 2dB 2h = 2.3dB 3h = 2.8dB
5	SSRX1_PRESHOOT_EN	R/W	1h	SSRX1 TX preshoot (pre-cursor) enabled. Valid only when SSRX_LIMIT_ENABLE = 1. 0h = Disabled (0dB) 1h = Enabled
4-3	SSRX1_DEEMPHASIS	R/W	1h	SSRX1 TX de-emphasis level (post-cursor) 0h = -1.5dB 1h = -2.1dB 2h = -3.2dB 3h = -3.8dB
2	SSRX1_DEEMPHASIS_EN	R/W	1h	SSRX1 TX de-emphasis (post-cursor) enable. Valid only when SSRX_LIMIT_ENABLE = 1. 0h = Disabled (0dB) 1h = Enabled
1-0	RESERVED	R/W	3h	Reserved

7.6.1.4 TX2EQ_CTRL Register (Offset = Ch) [Reset = 6Ch]

TX2EQ_CTRL is shown in [Table 7-14](#).

Return to the [Summary Table](#).

This register controls the pre-shoot and de-emphasis levels for SSRX2 when limited redriver mode is enabled.

Table 7-14. TX2EQ_CTRL Register Field Descriptions

Bit	Field	Type	Reset	Description
7-6	SSRX2_PRESHOOT	R/W	1h	SSRX2 TX preshoot level (pre-cursor). 0h = 1.5dB 1h = 2dB 2h = 2.3dB 3h = 2.8dB
5	SSRX2_PRESHOOT_EN	R/W	1h	SSRX2 TX preshoot (pre-cursor) enabled. Valid only when SSRX_LIMIT_ENABLE = 1. 0h = Disabled (0dB) 1h = Enabled
4-3	SSRX2_DEEMPHASIS	R/W	1h	SSRX2 TX de-emphasis level (post-cursor) 0h = -1.5dB 1h = -2.1dB 2h = -3.2dB 3h = -3.8dB
2	SSRX2_DEEMPHASIS_EN	R/W	1h	SSRX2 TX de-emphasis (post-cursor) enable. Valid only when SSRX_LIMIT_ENABLE = 1. 0h = Disabled (0dB) 1h = Enabled
1-0	RESERVED	R	0h	Reserved

7.6.1.5 AEQ_CONTROL1 Register (Offset = 1Ch) [Reset = 85h]

AEQ_CONTROL1 is shown in [Table 7-15](#).

Return to the [Summary Table](#).

This register is used to enable adaptive EQ and select between Fast and Full adaptive EQ.

Table 7-15. AEQ_CONTROL1 Register Field Descriptions

Bit	Field	Type	Reset	Description
7-4	FULLAEQ_UPPER_EQ	R/W	8h	This field sets the maximum EQ value to check for full AEQ mode when in I2C mode.
3	USB3_U1_DISABLE	R/W	0h	This field when set will cause entry to U3 instead of U1 when electrical idle is detected. 0h = U1 entry after electrical idle. 1h = U3 entry after electrical idle.
2-1	AEQ_MODE	R/W	2h	Selects Adaption mode (Fast, or one of three Full modes). 0h = Fast AEQ. 1h = Full AEQ, with hits counted at mideye for every EQ iteration (using current EQ setting). 2h = Full AEQ, algorithm II. 3h = Full AEQ, with hits counted at mideye only for first EQ iteration (using EQ set to the MID_HC_EQ value).
0	AEQ_EN	R/W	1h	Controls whether or not adaptive EQ for USB downstream facing port is enabled. 0h = AEQ disabled 1h = AEQ enabled

7.6.1.6 AEQ_CONTROL2 Register (Offset = 1Dh) [Reset = 10h]

AEQ_CONTROL2 is shown in [Table 7-16](#).

Return to the [Summary Table](#).

This register allows for controls for the Fast AEQ limits as well as adding or reducing final EQ value used by the Full AEQ function.

Table 7-16. AEQ_CONTROL2 Register Field Descriptions

Bit	Field	Type	Reset	Description
7	OVER_EQ_SIGN	R/W	0h	Selects the sign for OVER_EQ_CTRL field. 0h = positive 1h = negative
6	RESERVED	R	0h	Reserved
5-3	FASTAEQ_LIMITS	R/W	2h	Selects the upper/lower limits of DAC for determining short vs long channel. 0h = +/- 0mV 1h = +/- 40mV 2h = +/- 80mV 3h = +/- 120mV 4h = +/- 160mV 5h = +/- 200mV 6h = +/- 240mV 7h = +/- 280mV
2-0	OVER_EQ_CTRL	R/W	0h	This field will increase or decrease the AEQ by value programmed into this field. For example, full AEQ value is 6 and this field is programmed to 2 and OVER_EQ_SIGN = 0, then EQ value used will be 8. This field is only used in Full AEQ mode. 0h = 0 or -8 1h = 1 or -7 2h = 2 or -6 3h = 3 or -5 4h = 4 or -4 5h = 5 or -3 6h = 6 or -2 7h = 7 or -1

7.6.1.7 AEQ_LONG Register (Offset = 1Eh) [Reset = 77h]

AEQ_LONG is shown in [Table 7-17](#).

Return to the [Summary Table](#).

This register is used to program the EQ used for long channel setting when Fast AEQ is enabled.

Table 7-17. AEQ_LONG Register Field Descriptions

Bit	Field	Type	Reset	Description
7-4	LONG_CEQ2	R/W	7h	When AEQ_EN = 1 and AEQ_MODE = x0 (i.e., Fast), selects EQ setting for USB connector port2 (CRX2) when long channel is detected. The user should program this field with the value that provides the best Rx JTOL results for a long channel configuration.
3-0	LONG_CEQ1	R/W	7h	When AEQ_EN = 1 and AEQ_MODE = x0, selects EQ setting for USB connector port1 (CRX1) when long channel is detected. The user should program this field with the value that provides the best Rx JTOL results for a long channel configuration.

7.6.1.8 USBC_EQ Register (Offset = 20h) [Reset = 00h]

USBC_EQ is shown in [Table 7-18](#).

Return to the [Summary Table](#).

This register controls the receiver equalization setting for the connector receiver (CRX1 and CRX2).

Table 7-18. USBC_EQ Register Field Descriptions

Bit	Field	Type	Reset	Description
7-4	CEQ2_SEL	RH/W	0h	If AEQ_EN = 0, this field selects EQ for USB CRX2 receiver which faces the USB-C receptacle. When EQ_OVERRIDE = 0b, this field reflects the sampled state of CEQ[1:0] pins. When EQ_OVERRIDE = 1b, software can change the EQ setting for CRX2p/n pins based on value written to this field. When AEQ_EN = 1 and AEQ_MODE = x0, selects EQ setting for USB connector port2 (CRX2) when short channel is detected. The user should program this field with the value that provides the best Rx JTOL results for a short channel configuration.
3-0	CEQ1_SEL	RH/W	0h	If AEQ_EN = 0, this field selects EQ for USB CRX1 receiver which faces the USB-C receptacle. When EQ_OVERRIDE = 0b, this field reflects the sampled state of CEQ[1:0] pins. When EQ_OVERRIDE = 1b, software can change the EQ setting for CRX1p/n pins based on value written to this field. When AEQ_EN = 1 and AEQ_MODE = x0, selects EQ setting for USB connector port1 (CRX1) when short channel is detected. The user should program this field with the value that provides the best Rx JTOL results for a short channel configuration.

7.6.1.9 SS_EQ Register (Offset = 21h) [Reset = 00h]

SS_EQ is shown in [Table 7-19](#).

Return to the [Summary Table](#).

This register controls the receiver equalization setting for the SSTX1 and SSTX2.

Table 7-19. SS_EQ Register Field Descriptions

Bit	Field	Type	Reset	Description
7-4	SSEQ2_SEL	RH/W	0h	This field selects EQ for USB3 SSTX2 receiver which faces the USB host. When EQ_OVERRIDE = 0b, this field reflects the sampled state of SSEQ[1:0] pins. When EQ_OVERRIDE = 1b, software can change the EQ setting for SSTX2p/n pins based on value written to this field.

Table 7-19. SS_EQ Register Field Descriptions (continued)

Bit	Field	Type	Reset	Description
3-0	SSEQ1_SEL	RH/W	0h	This field selects EQ for USB SSTX1 receiver which faces the USB host. When EQ_OVERRIDE = 0b, this field reflects the sampled state of SSEQ[1:0] pins. When EQ_OVERRIDE = 1b, software can change the EQ setting for SSTX1p/n pins based on value written to this field.

7.6.1.10 USB3_MISC Register (Offset = 22h) [Reset = 04h]

USB3_MISC is shown in [Table 7-20](#).

Return to the [Summary Table](#).

Table 7-20. USB3_MISC Register Field Descriptions

Bit	Field	Type	Reset	Description
7	RXD_START_TERM	R/W	0h	Termination setting at start of RX detection following warm reset and at entry to SS.Inactive. 0h = Maintain termination. 1h = Turn off termination. Avoid compliance failures due to race between local and remote rxd in case of disconnect. If connection remains next state was polling regardless.
6-5	U23_RXDET_INTERVAL	R/W	0h	This field controls the Rx.Detect interval for the downstream facing port (CTX1P/N and CTX2P/N) when in U2/U3. 0h = 48ms 1h = 84ms 2h = 120ms 3h = 156ms
4	DISABLE_U2U3_RXDET	R/W	0h	Controls whether or not Rx.Detect is performed in U2/U3 state. 0h = Rx.Detect in U2/U3 enabled. 1h = Rx.Detect in U2/U3 disabled.
3-2	DFF_RXDET_INTERVAL	R/W	1h	This field controls the Rx.Detect interval for the downstream facing port (CTX1P/N and CTX2P/N). 0h = 4ms 1h = 6ms 2h = 36ms 3h = 84ms
1	DIS_WARM_RESET_RXD	R/W	0h	Disables receiver detection following warm reset if device starts polling during warm reset. 0h = whether receiver detection is done following warm reset depends on other settings. 1h = if USB FSM detects that device started polling during warm reset, it will not do receiver detection.
0	USB_COMPLIANCE_CTR L	R/W	0h	Controls whether compliance mode detection is determined by FSM or disabled 0h = Compliance mode determined by FSM. 1h = Compliance mode disabled.

7.6.1.11 USB1_STATUS Register (Offset = 24h) [Reset = 01h]

USB1_STATUS is shown in [Table 7-21](#).

Return to the [Summary Table](#).

Table 7-21. USB1_STATUS Register Field Descriptions

Bit	Field	Type	Reset	Description
7	USB1_FASTAEQ_STAT	RH	0h	When AEQ_EN = 1 and AEQ_MODE = x0, this status field indicates whether short or long EQ setting is used. When AEQ_EN = 0, this field will always default to 0h. 0h = Short channel EQ used. 1h = Long channel EQ used.

Table 7-21. USB1_STATUS Register Field Descriptions (continued)

Bit	Field	Type	Reset	Description
6	RESERVED	RH/W1C	0h	Reserved
5	RESERVED	RH	0h	Reserved
4	USB32_BY2_STAT1	RH	0h	This field is set if operating in USB3.2 x2. 0h = Operating in USB3.2 x1 1h = Operating in USB3.2 x2
3	CM_ACTIVE1	RH	0h	Compliance mode status. 0h = Not in USB3.1 compliance mode. 1h = In USB3.1 compliance mode.
2	U0_STAT1	RH	0h	U0 Status. Set if enters U0 state.
1	U2U3_STAT1	RH	0h	U2/U3 Status. Set if enters U2/U3 state.
0	DISC_STAT1	RH	1h	Disconnect Status. Set if enters Disconnect state.

7.6.1.12 USB2_STATUS Register (Offset = 25h) [Reset = 01h]

USB2_STATUS is shown in [Table 7-22](#).

Return to the [Summary Table](#).

Table 7-22. USB2_STATUS Register Field Descriptions

Bit	Field	Type	Reset	Description
7	USB2_FASTAEQ_STAT	RH	0h	When AEQ_EN = 1 and AEQ_MODE = x0, this status field indicates whether short or long EQ setting is used. When AEQ_EN = 0, this field will always default to 0h. 0h = Short channel EQ used. 1h = Long channel EQ used.
6	RESERVED	RH/W1C	0h	Reserved
5	RESERVED	RH	0h	Reserved
4	USB32_BY2_STAT2	RH	0h	This field is set if operating in USB3.2 x2. 0h = Operating in USB3.2 x1 1h = Operating in USB3.2 x2
3	CM_ACTIVE2	RH	0h	Compliance mode status. 0h = Not in USB3.1 compliance mode. 1h = In USB3.1 compliance mode.
2	U0_STAT2	RH	0h	U0 Status. Set if enters U0 state.
1	U2U3_STAT2	RH	0h	U2/U3 Status. Set if enters U2/U3 state.
0	DISC_STAT2	RH	1h	Disconnect Status. Set if enters Disconnect state.

7.6.1.13 VOD_CTRL Register (Offset = 32h) [Reset = C0h]

VOD_CTRL is shown in [Table 7-23](#).

Return to the [Summary Table](#).

This register controls the transmitters output linearity range for both UFP and DFP. When device is configured for limited redriver (SSRX_LIMIT_ENABLE field is set), USB_SSRX_VOD controls the VOD level for SSRX limited driver.

Table 7-23. VOD_CTRL Register Field Descriptions

Bit	Field	Type	Reset	Description
7-6	LFPS_VOD	R/W	3h	VOD linearity control for SSRX1, SSRX2, CTX1, and CTX2 when LFPS is being transmitted. 0h = LINR_L3 (highest) 1h = LINR_L2 2h = LINR_L1 3h = LINR_L0 (lowest)

Table 7-23. VOD_CTRL Register Field Descriptions (continued)

Bit	Field	Type	Reset	Description
5-4	RESERVED	R	0h	Reserved
3-2	USB_CTX12_VOD	R/W	0h	VOD linearity control for USB connector facing ports (CTX1 and CTX2). 0h = LINR_L3 (highest) 1h = LINR_L2 2h = LINR_L1 3h = LINR_L0 (lowest)
1-0	USB_SSRX12_VOD	R/W	0h	VOD linearity control for USB upstream facing port (SSRX1/2). When SSRX_LIMIT_ENABLE = 1, then this field controls the limited VOD for SSRX. 0h = LINR_L3 (highest) 1h = LINR_L2 2h = LINR_L1 3h = LINR_L0 (lowest)

7.6.1.14 AEQ1_STATUS Register (Offset = 3Bh) [Reset = 00h]

AEQ1_STATUS is shown in [Table 7-24](#).

Return to the [Summary Table](#).

This register provides the status of AEQ function.

Table 7-24. AEQ1_STATUS Register Field Descriptions

Bit	Field	Type	Reset	Description
7-5	RESERVED	R	0h	Reserved
4	RESERVED	RH	0h	Reserved
3-0	AEQ1_EQ_STAT	RH	0h	Optimal EQ determined by FSM after the completion of Full AEQ. This field will also indicate EQ used for Fast AEQ. This field will include the value programmed into OVER_EQ_CTRL field.

7.6.1.15 AEQ2_STATUS Register (Offset = 3Ch) [Reset = 00h]

AEQ2_STATUS is shown in [Table 7-25](#).

Return to the [Summary Table](#).

This register provides the status of AEQ function.

Table 7-25. AEQ2_STATUS Register Field Descriptions

Bit	Field	Type	Reset	Description
7-5	RESERVED	R	0h	Reserved
4	RESERVED	RH	0h	Reserved
3-0	AEQ2_EQ_STAT	RH	0h	Optimal EQ determined by FSM after the completion of Full AEQ. This field will also indicate EQ used for Fast AEQ. This field will include the value programmed into OVER_EQ_CTRL field.

7.6.1.16 AEQ_CONTROL_AUX1 Register (Offset = 50h) [Reset = 00h]

AEQ_CONTROL_AUX1 is shown in [Table 7-26](#).

Return to the [Summary Table](#).

Table 7-26. AEQ_CONTROL_AUX1 Register Field Descriptions

Bit	Field	Type	Reset	Description
7-6	RESERVED	R	0h	Reserved

Table 7-26. AEQ_CONTROL_AUX1 Register Field Descriptions (continued)

Bit	Field	Type	Reset	Description
5-2	RESERVED	R	0h	Reserved
1-0	RESERVED	R	0h	Reserved

7.6.1.17 AEQ_CONTROL_AUX2 Register (Offset = 51h) [Reset = 07h]

AEQ_CONTROL_AUX2 is shown in [Table 7-27](#).

Return to the [Summary Table](#).

Table 7-27. AEQ_CONTROL_AUX2 Register Field Descriptions

Bit	Field	Type	Reset	Description
7-5	RESERVED	R	0h	Reserved
4	EQ_MERGE	R/W	0h	Initial EQ result merge control. This field controls how the EQ results from the positive and negative VOD offsets steps are merged to produce the initial EQ value. This field is applicable only when the AEQ_MODE field is set to 2'b10. 0h = Use max of pos/neg VOD EQs 1h = Use min of pos/neg VOD EQs
3-0	MID_HC_EQ	R/W	7h	Sets EQ value during the mid-eye hit-count capture step. This field is applicable only when the AEQ_MODE field is set to 2'b10 or 2'b11.

7.6.1.18 AEQ_CONTROL_AUX3 Register (Offset = 52h) [Reset = 86h]

AEQ_CONTROL_AUX3 is shown in [Table 7-28](#).

Return to the [Summary Table](#).

Table 7-28. AEQ_CONTROL_AUX3 Register Field Descriptions

Bit	Field	Type	Reset	Description
7-5	HC_EQ_THR	R/W	4h	Sets the hit-count threshold during the EQ search steps. The algorithm will find the minimum EQ setting such that the hit-count is at or above value N_{eq} , where: $N_{eq} = HC_{me} * (128 - HC_{EQ_THR}) / 128$ and HC_{me} is the mid-eye hit-count. This field is applicable only when the AEQ_MODE field is set to 2'b10.
4	RESERVED	R	0h	Reserved
3-0	HC_VOD_THR	R/W	6h	Sets the hit-count threshold during the VOD search steps. The algorithm will find the maximum DAC VOD setting such that the hit-count is at or above the threshold value N_{vod} , where: $N_{vod} = HC_{me} * HC_{VOD_THR} / 128$ and HC_{me} is the mid-eye hit-count. This field is applicable only when the AEQ_MODE field is set to 2'b10.

8 Application and Implementation

Note

Information in the following applications sections is not part of the TI component specification, and TI does not warrant its accuracy or completeness. TI's customers are responsible for determining suitability of components for their purposes, as well as validating and testing their design implementation to confirm system functionality.

8.1 Application Information

The TUSB1104 is a linear redriver designed specifically to compensate for intersymbol interference (ISI) jitter causes by signal attenuation through a passive medium like PCB traces or cables. Placing the TUSB1104 between the USB connector and a USB 3.2 host, hub, and device can correct signal integrity issues resulting in a more robust system.

9 Typical Application

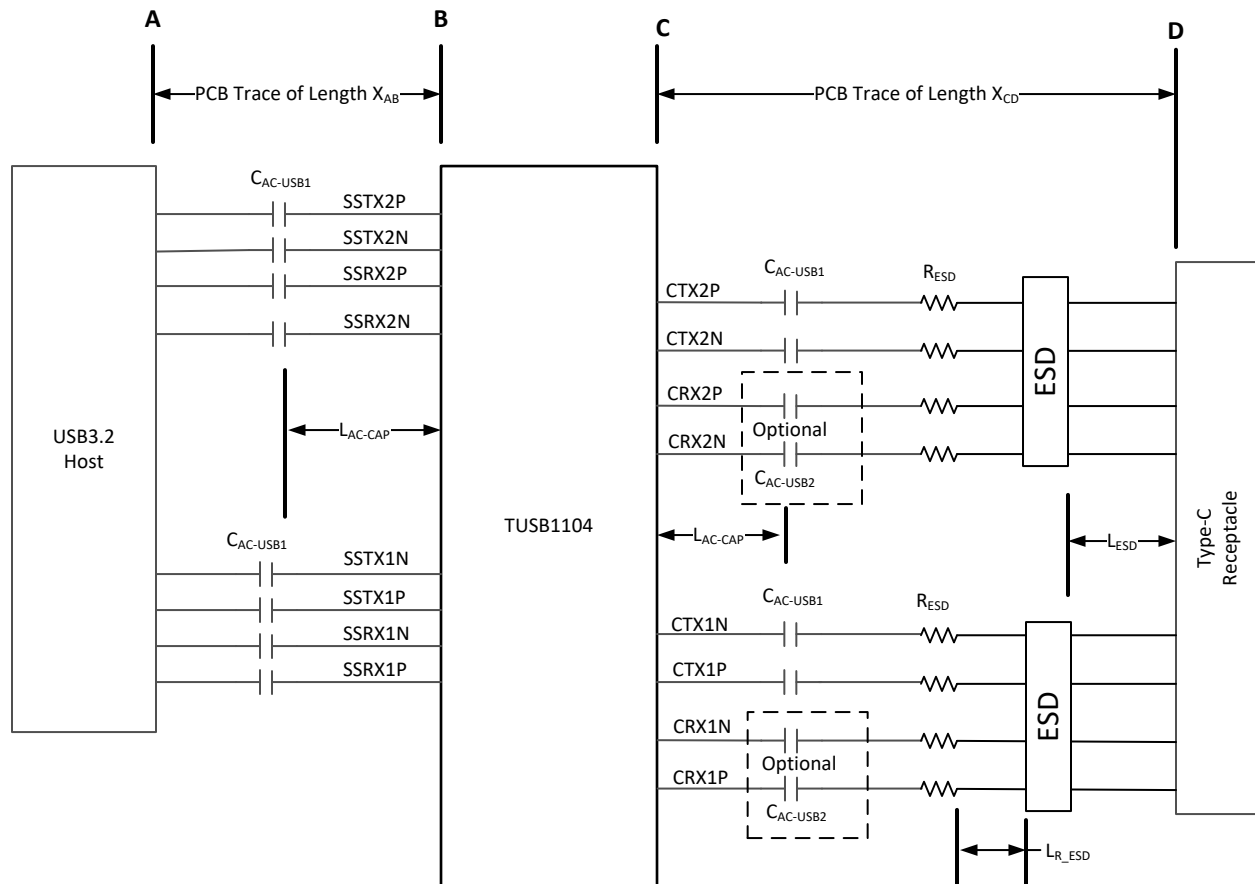

Figure 9-1. Typical USB Host Application

10 Design Requirements

For this design example, use the parameters shown in [Table 10-1](#).

Table 10-1. Design Parameters

PARAMETER	VALUE
10Gbps USB 3.2 pre-channel A to B PCB trace length, X_{AB} . Refer to Figure 9-1 .	2 inches $\leq X_{AB} \leq$ 12 inches - X_{CD}
10Gbps USB post-channel C to D PCB trace length, X_{CD} . Refer to Figure 9-1 .	up to 4 inches
Minimum distance of the AC capacitors from TUSB1104, L_{AC-CAP}	0.4 inches
Maximum distance of ESD component from the USB receptacle, L_{ESD}	1.0 inches
Maximum distance of series resistor (R_{ESD}) from ESD component, L_{R_ESD} .	0.25 inches
$C_{AC-USB1}$ AC-coupling capacitor (75 nF to 265 nF)	220 nF
$C_{AC-USB2}$ AC-coupling capacitor (297 nF to 363 nF)	Options: <ul style="list-style-type: none"> • RX1 and RX2 are DC-coupled to USB receptacle • 330 nF AC-couple with R_{RX} resistor
Optional R_{RX} resistor (220-k Ω \pm 5%)	No used
R_{ESD} (0- Ω to 2.2- Ω)	1- Ω
V_{CC} supply (3-V to 3.6-V)	3.3-V
I ² C Mode or Pin-strap Mode	I ² C Mode. (MODE = "F")
1.8-V or 3.3-V I ² C Interface	3.3-V I ² C. VIO_SEL pin to Float "F".

11 Detailed Design Procedure

A typical usage of the TUSB1104 device is shown in [Figure 11-1](#). The device can be configure either through its GPIO pins or through its I²C interface. In the following example, a Type-C PD controller or microcontroller is used to configure the device through the I²C interface. In I²C mode, the equalization settings for each receiver can be independently controlled through I²C registers. For this reason, all of the equalization pins (SSEQ[1:0], and CEQ[1:0]) can be left unconnected. If these pins are left unconnected, the TUSB1104 7-bit I2C target address will be 0x12 because both SSEQ1/A1 and SSEQ0/A0 will be at pin level F. If a different I2C target address is desired, SSEQ1/A1 and SSEQ0/A0 pins should be set to a level which produces the desired I2C target address.

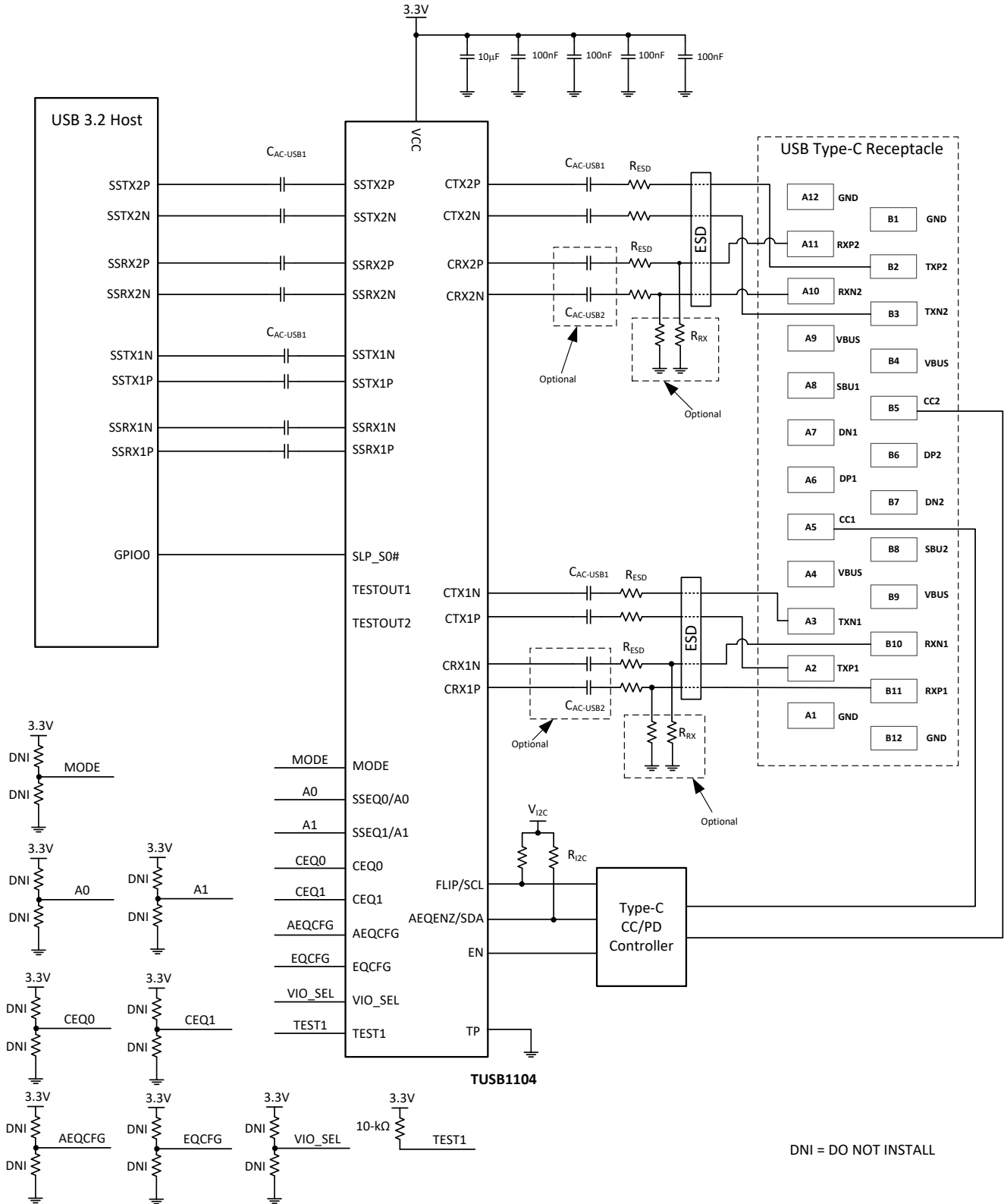

Figure 11-1. Application Circuit

11.1 USB SSTX1/2 Receiver Configuration

Configuring the TUSB1104 involves understanding the insertion loss (SDD21) of the pre-channel (X_{AB}). The TUSB1104's SSEQ[1:0] pins if pin-strap mode, or if I2C mode, SSEQ2_SEL and SSEQ1_SEL registers should be set to the level of the pre-channel insertion loss at 5 GHz. A good rule for FR4 trace insertion loss at 5 GHz is ≈ -1 dB per inch. Using this rule, if the pre-channel for USB (X_{AB}) is 8-inches, the TUSB1104 SSEQ should be programmed to -8 dB.

11.2 USB CRX1/2 Receiver Configuration

11.2.1 Fixed Equalization

In Fixed EQ operation, a single EQ setting is used for all possible devices inserted into the USB receptacle (with or without USB cable). It is recommended to set TUSB1104 CEQ[1:0] pins if pin-strap mode, or CEQ1_SEL and CEQ2_SEL if I2C mode to about 4 dB to 5 dB greater than loss of the post channel (X_{CD}). For example, if post channel is 0.5 inches, then assuming -1 dB per inch at 5 GHz, CEQ1_SEL and CEQ2_SEL should be programmed to 4.5 to 5.5 dB. It is recommended to perform USB 3.1 Rx JTOL long and short channel tests to optimize the setting. Depending of the USB 3.2 Host, a single EQ setting which satisfies both the long and short channel tests may not be possible. If this is the case, then it is recommended to use AEQ mode.

11.2.2 Full Adaptive Equalization

In Full AEQ mode, the TUSB1104 will determine the best settings regardless if the channel is short, long or somewhere in between. In pin-strap mode, the Full AEQ is enabled based on the state of AEQENZ pin. In I2C mode, the Full AEQ feature is enabled by default. Full AEQ is enabled when AEQ_MODE = 1, 2, or 3, and AEQ_EN = 0x1.

11.2.3 Fast Adaptive Equalization

Fast Adaptive EQ will distinguish between a short and long channel and select a pre-determined EQ setting based on which channel is detected. Fast AEQ is available only I2C mode. Fast AEQ is enabled when AEQ_MODE = 0 and AEQ_EN = 1.

The EQ setting used for short channel should be programmed into CEQ1_SEL and CEQ2_SEL registers. It is recommended to program these registers about 1 dB to 2 dB more than the loss of post channel (X_{CD}). For example, if post channel is 0.5 inches, then assuming -1dB insertion loss per inch at 5 GHz, CEQ1_SEL and CEQ2_SEL should be programmed to 1.5 to 2.5 dB. It is recommended to perform USB 3.2 Rx JTOL Short channel test to find the optimal short channel setting.

The EQ setting used for long channel should be programmed into LONG_CEQ1 and LONG_CEQ2. It is recommended to program these registers about 4 to 5 dB more than the loss of post channel (X_{CD}). For example, if post channel is 0.5 inches, then assuming -1 dB per inch at 5 GHz, LONG_CEQ1 and LONG_CEQ2 should be programmed to 4.5 to 5.5 dB. It is recommended to perform USB 3.2 Rx JTOL Long channel test to find the optimal long channel setting.

12 Application Curves

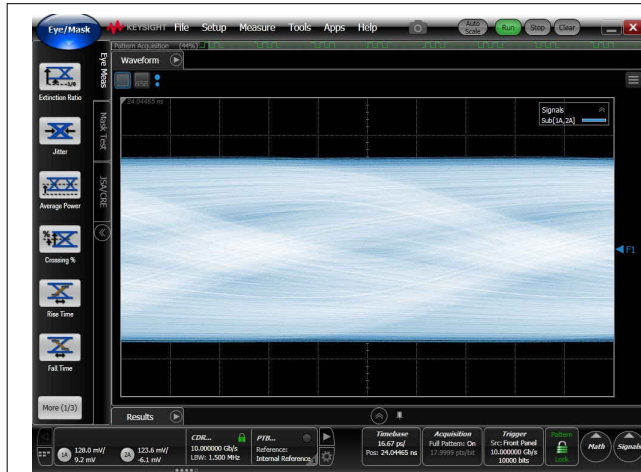

Figure 12-1. 10 Gbps Input Eye At SSTX1 After 12.5 dB at 5 GHz Pre-channel

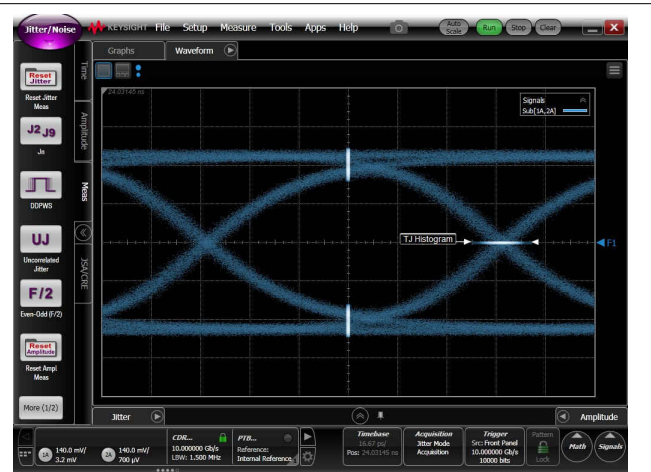

Figure 12-2. 10 Gbps Output Eye at CTX1 After 1.2 dB at 5 GHz Post-Channel

13 Power Supply Recommendations

The TUSB1104 is designed to operate with a 3.3 V power supply. Levels above those listed in the *Absolute Maximum Ratings* table should not be used. If using a higher voltage system power supply, a voltage regulator can be used to step down to 3.3 V. Decoupling capacitors should be used to reduce noise and improve power supply integrity. A 0.1 μ F de-coupling capacitor should be used on each power pin. The de-coupling capacitor should be placed close as possible to the power pin. It is also recommended to have a single bulk capacitor of 1 μ F to 10 μ F.

14 Layout

14.1 Layout Guidelines

1. SSTX1P/N, SSRX1P/N, SSTX2P/N, SSRX2P/N, CRX1P/N, CRX2P/N, CTX1P/N, and CTX2P/N pairs should be routed with controlled 90- Ω differential impedance ($\pm 10\%$).
2. Keep away from other high speed signals.
3. Intra-pair routing (between P and N) should be kept to less than 5 mils.
4. Length matching should be near the location of mismatch.
5. Each pair should be separated at least by 3 times the signal trace width.
6. The use of bends in differential traces should be kept to a minimum. When bends are used, the number of left and right bends should be as equal as possible and the angle of the bend should be ≥ 135 degrees. This will minimize any length mismatch caused by the bends and therefore minimize the impact bends have on EMI.
7. Route all differential pairs on the same of layer.
8. The number of vias should be kept to a minimum. It is recommended to keep the vias count to 2 or less.
9. Keep traces on layers adjacent to ground plane.
10. Do not route differential pairs over any plane split.
11. Adding Test points will cause impedance discontinuity, and therefore, negatively impact signal performance. If test points are used, they should be placed in series and symmetrically. They must not be placed in a manner that causes a stub on the differential pair.
12. Highly recommended to have reference plane void under USB-C receptacle's super speed pins to minimize the capacitance effect of the receptacle.
13. Highly recommended to have reference plane void under the AC-coupling capacitances.

14.2 Layout Example

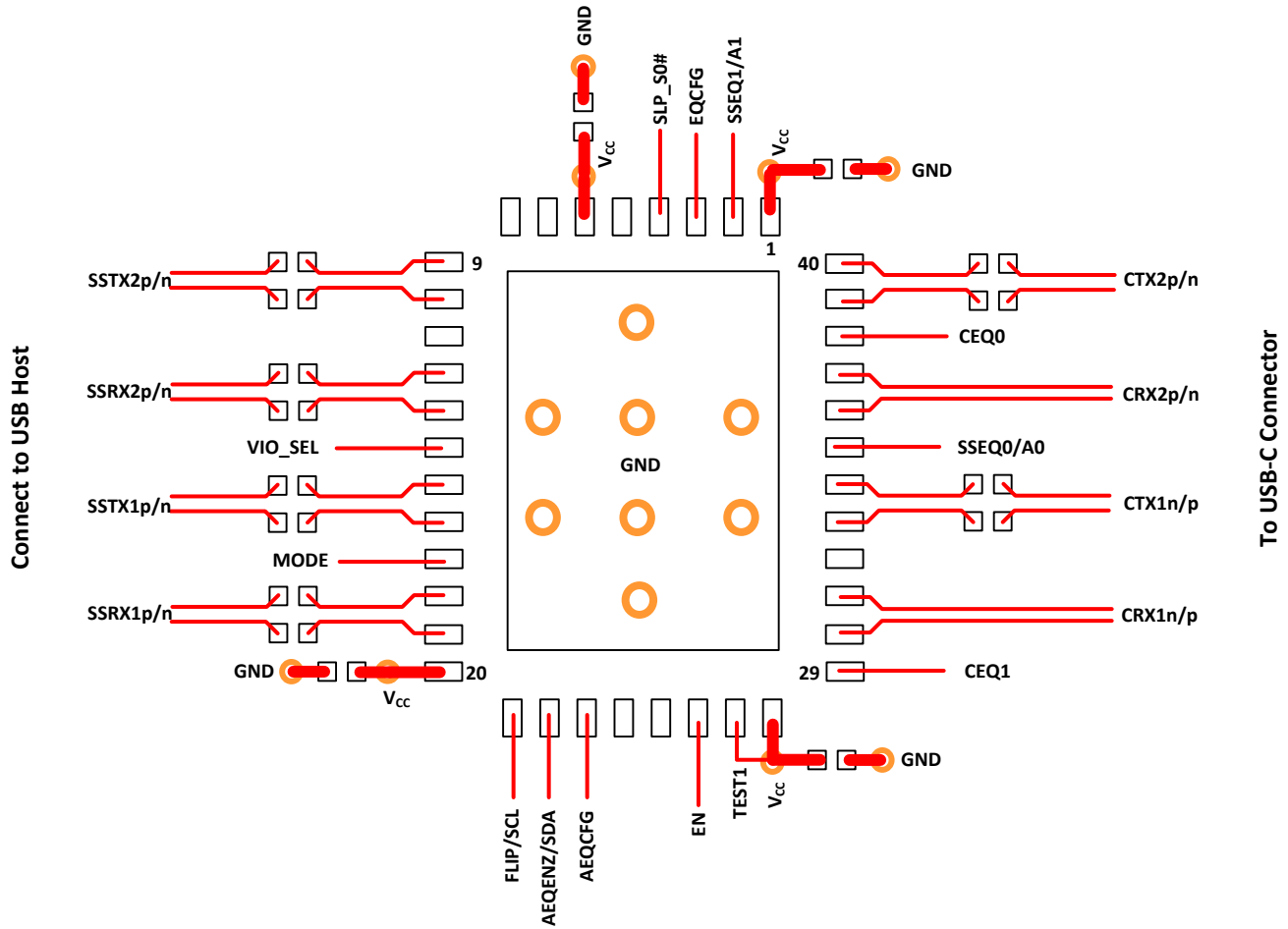

Figure 14-1. Layout Example

15 Device and Documentation Support

TI offers an extensive line of development tools. Tools and software to evaluate the performance of the device, generate code, and develop solutions are listed below.

15.1 Receiving Notification of Documentation Updates

To receive notification of documentation updates, navigate to the device product folder on ti.com. Click on *Subscribe to updates* to register and receive a weekly digest of any product information that has changed. For change details, review the revision history included in any revised document.

15.2 Support Resources

[TI E2E™ support forums](#) are an engineer's go-to source for fast, verified answers and design help — straight from the experts. Search existing answers or ask your own question to get the quick design help you need.

Linked content is provided "AS IS" by the respective contributors. They do not constitute TI specifications and do not necessarily reflect TI's views; see TI's [Terms of Use](#).

15.3 Trademarks

USB Type-C™ is a trademark of USB Implementers Forum.

TI E2E™ is a trademark of Texas Instruments.

All trademarks are the property of their respective owners.

15.4 Electrostatic Discharge Caution



This integrated circuit can be damaged by ESD. Texas Instruments recommends that all integrated circuits be handled with appropriate precautions. Failure to observe proper handling and installation procedures can cause damage.

ESD damage can range from subtle performance degradation to complete device failure. Precision integrated circuits may be more susceptible to damage because very small parametric changes could cause the device not to meet its published specifications.

15.5 Glossary

[TI Glossary](#) This glossary lists and explains terms, acronyms, and definitions.

16 Mechanical, Packaging, and Orderable Information

The following pages include mechanical, packaging, and orderable information. This information is the most current data available for the designated devices. This data is subject to change without notice and revision of this document. For browser-based versions of this data sheet, refer to the left-hand navigation.

PACKAGING INFORMATION

Orderable Device	Status (1)	Package Type	Package Drawing	Pins	Package Qty	Eco Plan (2)	Lead finish/ Ball material (6)	MSL Peak Temp (3)	Op Temp (°C)	Device Marking (4/5)	Samples
TUSB1104IRNQR	ACTIVE	WQFN	RNQ	40	3000	RoHS & Green	NIPDAU	Level-2-260C-1 YEAR	-40 to 85	TSB04	Samples
TUSB1104IRNQT	ACTIVE	WQFN	RNQ	40	250	RoHS & Green	NIPDAU	Level-2-260C-1 YEAR	-40 to 85	TSB04	Samples
TUSB1104RNQR	ACTIVE	WQFN	RNQ	40	3000	RoHS & Green	NIPDAU	Level-2-260C-1 YEAR	0 to 70	TSB04	Samples
TUSB1104RNQT	ACTIVE	WQFN	RNQ	40	250	RoHS & Green	NIPDAU	Level-2-260C-1 YEAR	0 to 70	TSB04	Samples

(1) The marketing status values are defined as follows:

ACTIVE: Product device recommended for new designs.

LIFEBUY: TI has announced that the device will be discontinued, and a lifetime-buy period is in effect.

NRND: Not recommended for new designs. Device is in production to support existing customers, but TI does not recommend using this part in a new design.

PREVIEW: Device has been announced but is not in production. Samples may or may not be available.

OBSELETE: TI has discontinued the production of the device.

(2) **RoHS:** TI defines "RoHS" to mean semiconductor products that are compliant with the current EU RoHS requirements for all 10 RoHS substances, including the requirement that RoHS substance do not exceed 0.1% by weight in homogeneous materials. Where designed to be soldered at high temperatures, "RoHS" products are suitable for use in specified lead-free processes. TI may reference these types of products as "Pb-Free".

RoHS Exempt: TI defines "RoHS Exempt" to mean products that contain lead but are compliant with EU RoHS pursuant to a specific EU RoHS exemption.

Green: TI defines "Green" to mean the content of Chlorine (Cl) and Bromine (Br) based flame retardants meet JS709B low halogen requirements of <=1000ppm threshold. Antimony trioxide based flame retardants must also meet the <=1000ppm threshold requirement.

(3) MSL, Peak Temp. - The Moisture Sensitivity Level rating according to the JEDEC industry standard classifications, and peak solder temperature.

(4) There may be additional marking, which relates to the logo, the lot trace code information, or the environmental category on the device.

(5) Multiple Device Markings will be inside parentheses. Only one Device Marking contained in parentheses and separated by a "-" will appear on a device. If a line is indented then it is a continuation of the previous line and the two combined represent the entire Device Marking for that device.

(6) Lead finish/Ball material - Orderable Devices may have multiple material finish options. Finish options are separated by a vertical ruled line. Lead finish/Ball material values may wrap to two lines if the finish value exceeds the maximum column width.

Important Information and Disclaimer:The information provided on this page represents TI's knowledge and belief as of the date that it is provided. TI bases its knowledge and belief on information provided by third parties, and makes no representation or warranty as to the accuracy of such information. Efforts are underway to better integrate information from third parties. TI has taken and

continues to take reasonable steps to provide representative and accurate information but may not have conducted destructive testing or chemical analysis on incoming materials and chemicals. TI and TI suppliers consider certain information to be proprietary, and thus CAS numbers and other limited information may not be available for release.

In no event shall TI's liability arising out of such information exceed the total purchase price of the TI part(s) at issue in this document sold by TI to Customer on an annual basis.

TAPE AND REEL INFORMATION

QUADRANT ASSIGNMENTS FOR PIN 1 ORIENTATION IN TAPE

*All dimensions are nominal

Device	Package Type	Package Drawing	Pins	SPQ	Reel Diameter (mm)	Reel Width W1 (mm)	A0 (mm)	B0 (mm)	K0 (mm)	P1 (mm)	W (mm)	Pin1 Quadrant
TUSB1104IRNQR	WQFN	RNQ	40	3000	330.0	12.4	4.3	6.3	1.1	8.0	12.0	Q2
TUSB1104IRNQT	WQFN	RNQ	40	250	180.0	12.4	4.3	6.3	1.1	8.0	12.0	Q2
TUSB1104RNQR	WQFN	RNQ	40	3000	330.0	12.4	4.3	6.3	1.1	8.0	12.0	Q2
TUSB1104RNQT	WQFN	RNQ	40	250	180.0	12.4	4.3	6.3	1.1	8.0	12.0	Q2

TAPE AND REEL BOX DIMENSIONS

*All dimensions are nominal

Device	Package Type	Package Drawing	Pins	SPQ	Length (mm)	Width (mm)	Height (mm)
TUSB1104IRNQR	WQFN	RNQ	40	3000	367.0	367.0	35.0
TUSB1104IRNQT	WQFN	RNQ	40	250	210.0	185.0	35.0
TUSB1104RNQR	WQFN	RNQ	40	3000	367.0	367.0	35.0
TUSB1104RNQT	WQFN	RNQ	40	250	210.0	185.0	35.0

RNQ0040A

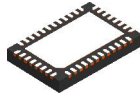

PACKAGE OUTLINE

WQFN - 0.8 mm max height

PLASTIC QUAD FLATPACK - NO LEAD

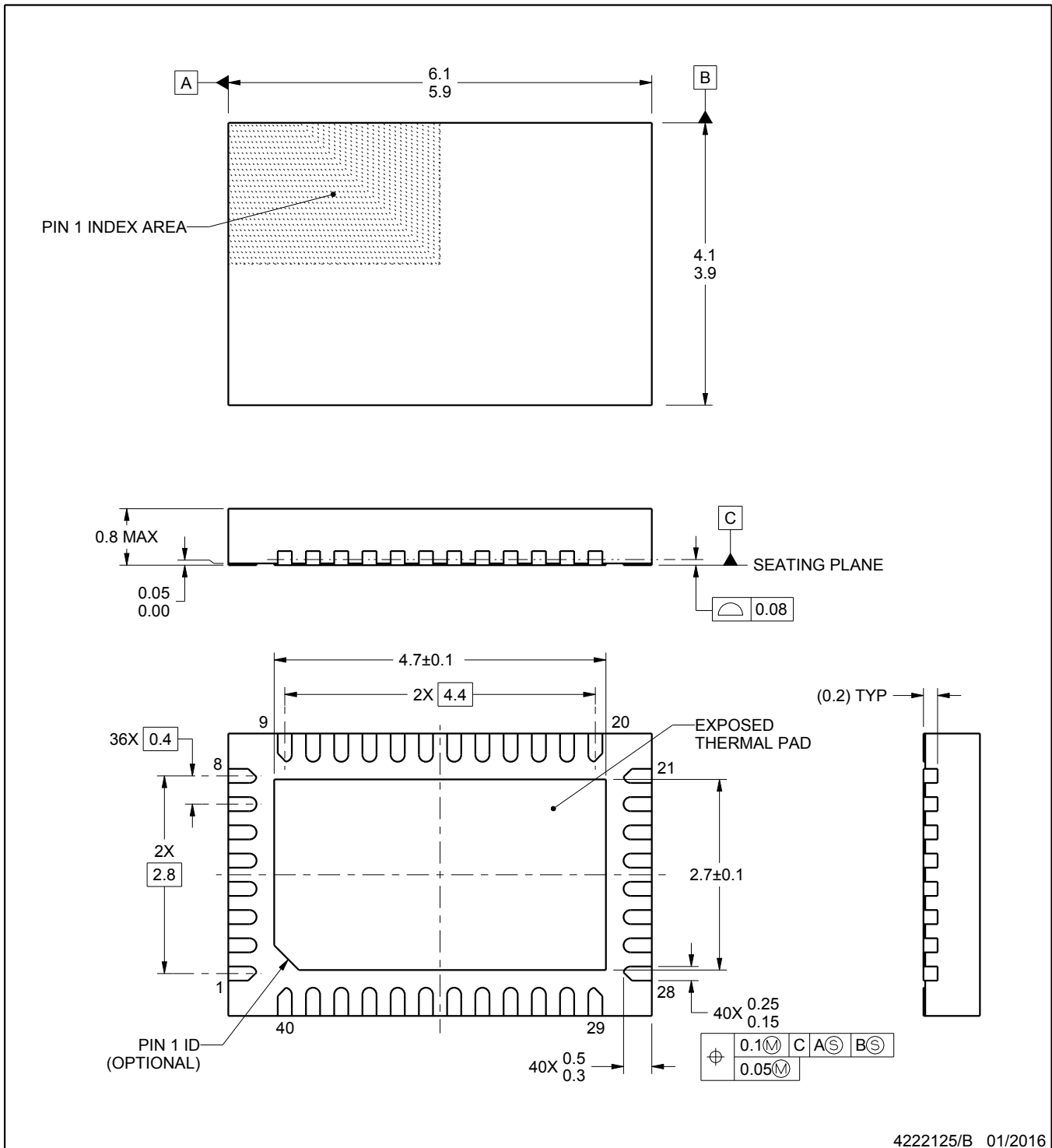

4222125/B 01/2016

NOTES:

1. All linear dimensions are in millimeters. Any dimensions in parenthesis are for reference only. Dimensioning and tolerancing per ASME Y14.5M.
2. This drawing is subject to change without notice.
3. The package thermal pad must be soldered to the printed circuit board for thermal and mechanical performance.

EXAMPLE BOARD LAYOUT

RNQ0040A

WQFN - 0.8 mm max height

PLASTIC QUAD FLATPACK - NO LEAD

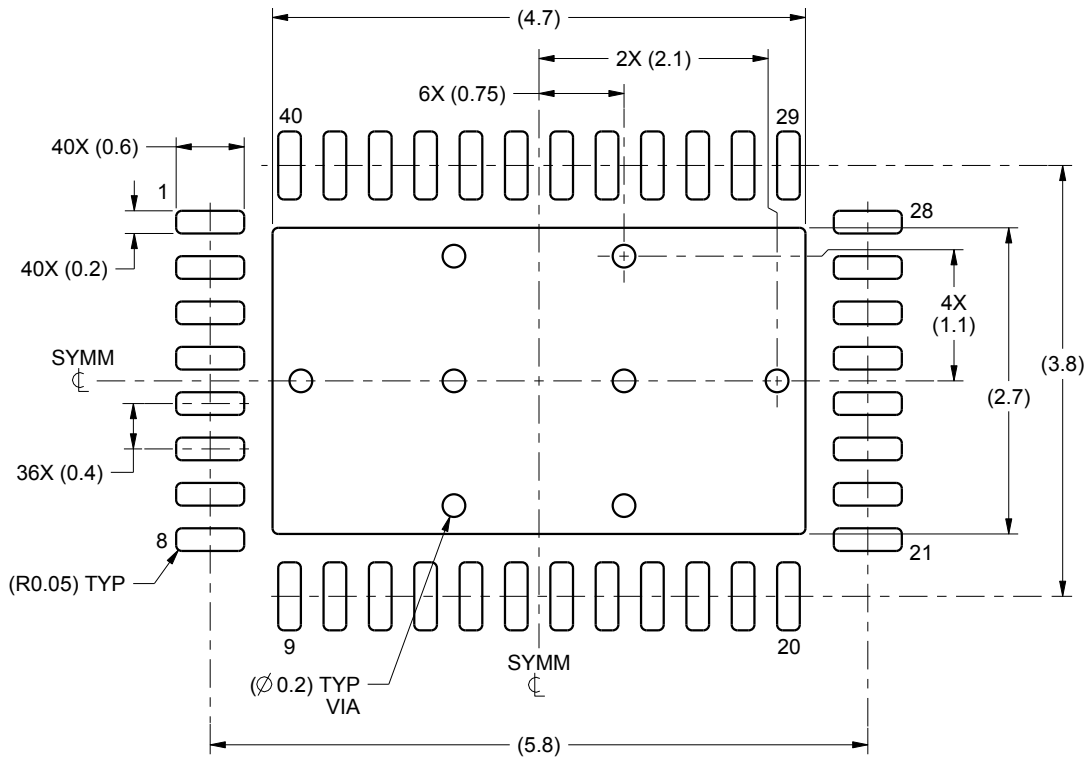

LAND PATTERN EXAMPLE
SCALE:15X

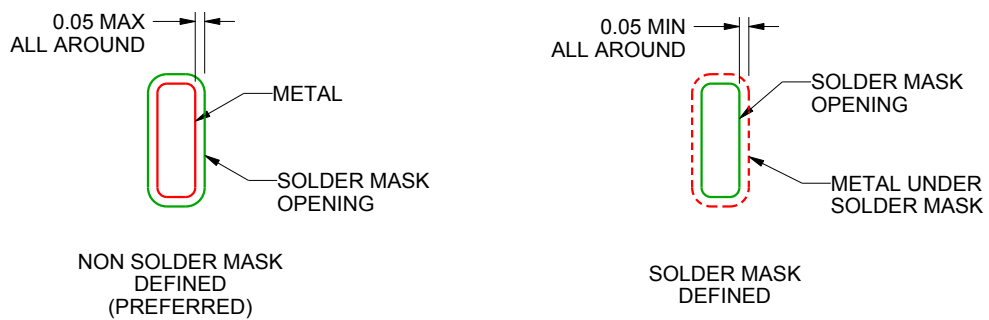

SOLDER MASK DETAILS

4222125/B 01/2016

NOTES: (continued)

- This package is designed to be soldered to a thermal pad on the board. For more information, see Texas Instruments literature number SLUA271 (www.ti.com/lit/slua271).

EXAMPLE STENCIL DESIGN

RNQ0040A

WQFN - 0.8 mm max height

PLASTIC QUAD FLATPACK - NO LEAD

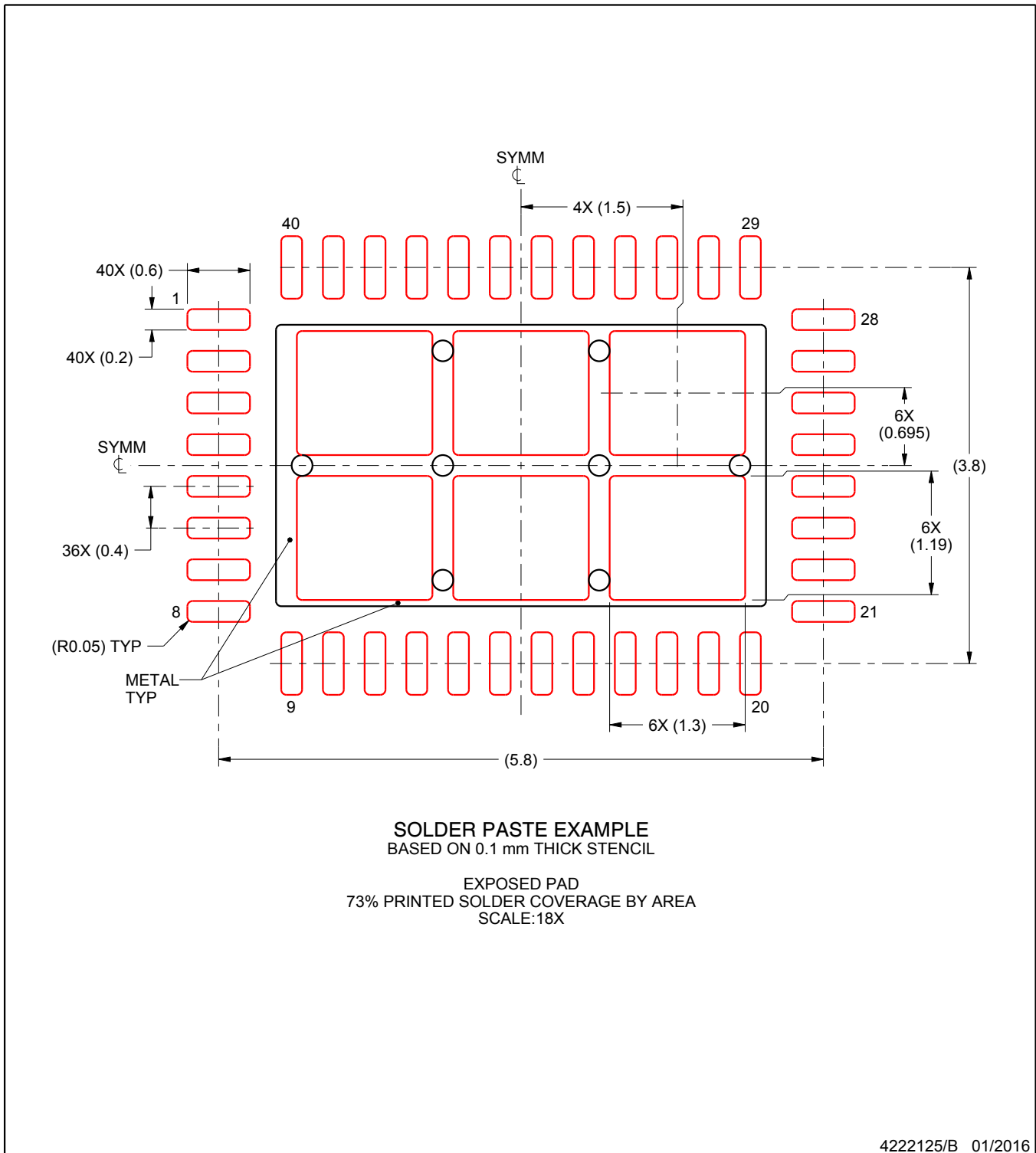

NOTES: (continued)

5. Laser cutting apertures with trapezoidal walls and rounded corners may offer better paste release. IPC-7525 may have alternate design recommendations.

IMPORTANT NOTICE AND DISCLAIMER

TI PROVIDES TECHNICAL AND RELIABILITY DATA (INCLUDING DATA SHEETS), DESIGN RESOURCES (INCLUDING REFERENCE DESIGNS), APPLICATION OR OTHER DESIGN ADVICE, WEB TOOLS, SAFETY INFORMATION, AND OTHER RESOURCES "AS IS" AND WITH ALL FAULTS, AND DISCLAIMS ALL WARRANTIES, EXPRESS AND IMPLIED, INCLUDING WITHOUT LIMITATION ANY IMPLIED WARRANTIES OF MERCHANTABILITY, FITNESS FOR A PARTICULAR PURPOSE OR NON-INFRINGEMENT OF THIRD PARTY INTELLECTUAL PROPERTY RIGHTS.

These resources are intended for skilled developers designing with TI products. You are solely responsible for (1) selecting the appropriate TI products for your application, (2) designing, validating and testing your application, and (3) ensuring your application meets applicable standards, and any other safety, security, regulatory or other requirements.

These resources are subject to change without notice. TI grants you permission to use these resources only for development of an application that uses the TI products described in the resource. Other reproduction and display of these resources is prohibited. No license is granted to any other TI intellectual property right or to any third party intellectual property right. TI disclaims responsibility for, and you will fully indemnify TI and its representatives against, any claims, damages, costs, losses, and liabilities arising out of your use of these resources.

TI's products are provided subject to [TI's Terms of Sale](#) or other applicable terms available either on ti.com or provided in conjunction with such TI products. TI's provision of these resources does not expand or otherwise alter TI's applicable warranties or warranty disclaimers for TI products.

TI objects to and rejects any additional or different terms you may have proposed.

Mailing Address: Texas Instruments, Post Office Box 655303, Dallas, Texas 75265
Copyright © 2022, Texas Instruments Incorporated