

DUAL NON-INVERTING POWER DRIVER

FEATURES

- 3.0A Peak Current Totem Pole Output
- 5 to 35V Operation
- 25ns Rise and Fall Times
- 25ns Propagation Delays
- Thermal Shutdown and Under-Voltage Protection
- High-Speed, Power MOSFET Compatible
- Efficient High Frequency Operation
- Low Cross-Conduction Current Spike
- Enable and Shutdown Functions
- Wide Input Voltage Range
- ESD Protection to 2kV

DESCRIPTION

The UC1708 family of power drivers is made with a high-speed, high-voltage, Schottky process to interface control functions and high-power switching devices – particularly power MOSFETs. Operating over a 5 V to 35 V supply range, these devices contain two independent channels. The A and B inputs are compatible with TTL and CMOS logic families, but can withstand input voltages as high as V_{IN} . Each output can source or sink up to 3 A as long as power dissipation limits are not exceeded.

Although each output can be activated independently with its own inputs, they can be forced low in common through the action of either a digital high signal at the Shutdown terminal or by forcing the Enable terminal low. The Shutdown terminal will only force the outputs low, it will not effect the behavior of the rest of the device. The Enable terminal effectively places the device in under-voltage lockout, reducing power consumption by as much as 90%. During under-voltage and disable (Enable terminal forced low) conditions, the outputs are held in a self-biasing, low-voltage, state.

The UC3708 and UC2708 are available in plastic 8-pin MINI DIP and 16-pin *bat-wing* DIP packages for commercial operation over a 0°C to 70°C temperature range and industrial temperature range of –25°C to 85°C respectively. For operation over a –55°C to 125°C temperature range, the UC1708 is available in hermetically sealed 8-pin MINI CDIP, 16 pin CDIP and 20 pin CLCC packages. Surface mount devices are also available.

BLOCK DIAGRAM

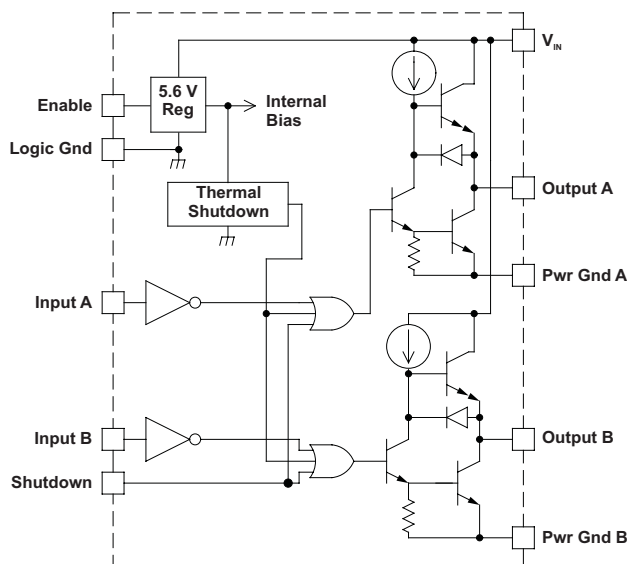

NOTE: Shutdown feature is not available in J or N packages only.



Please be aware that an important notice concerning availability, standard warranty, and use in critical applications of Texas Instruments semiconductor products and disclaimers thereto appears at the end of this data sheet.

CONNECTION DIAGRAMS

DIL-8 (Top View)
J Or N Package

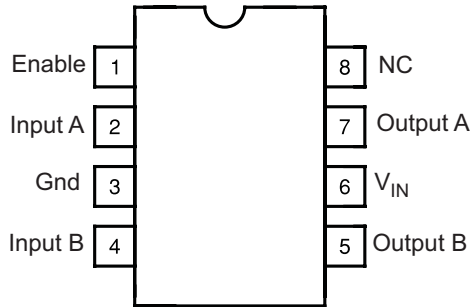

SOIC-16 (Top View)
DW Package

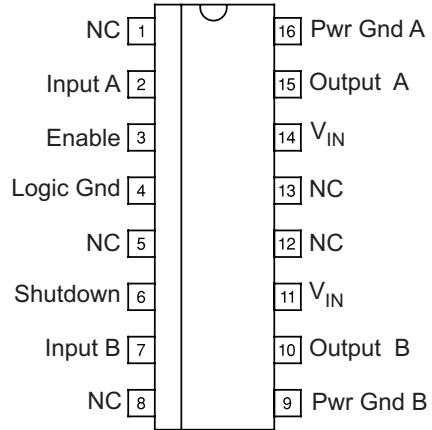

DIL-16 (Top View)
JE Or NE Package

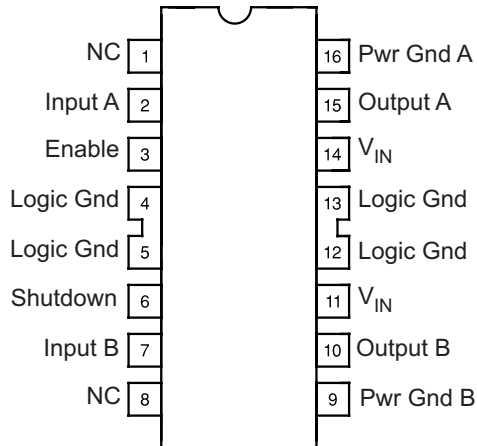

Note: In JE package, Pin 4 is Logic Ground.
Pins 5, 12, and 13 are no connect.

CLCC-20 (Top View)
L Package

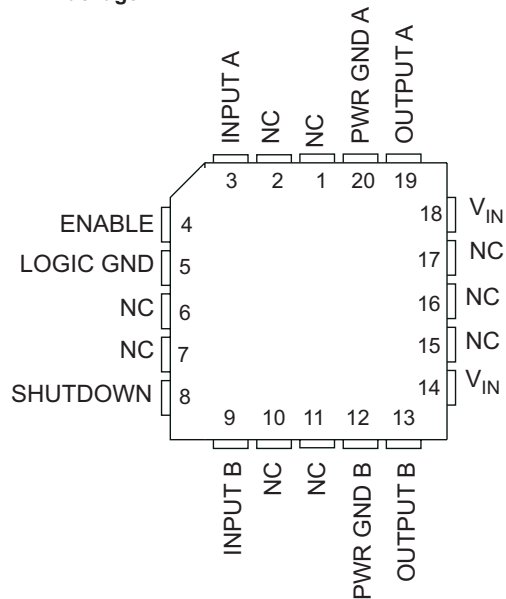

ABSOLUTE MAXIMUM RATINGS⁽¹⁾

	VALUE	UNIT
Supply Voltage, V_{IN}	35	V
Output Current (Each Output, Source or Sink)	Steady-State	0.5
	Peak Transient	3
Output Voltage	-0.3 to ($V_{IN} + 0.3$)	V
Enable and Shutdown Inputs	-0.3 to 6.2	V
A and B Inputs	-0.3 to ($V_{IN} + 0.3$)	V
Operating Junction Temperature ⁽²⁾	150	°C
Storage Temperature Range	-65 to 150	°C
Lead Temperature (Soldering, 10 Seconds)	300	°C

(1) All voltages are with respect to Logic Gnd pin. All currents are positive into, negative out of, device terminals.

(2) Consult Unitorde Integrated Circuits databook for information regarding thermal specifications and limitations of packages.

ELECTRICAL CHARACTERISTICS

Unless otherwise stated, $V_{IN}=10V$ to 35V, and these specifications apply for: $-55^{\circ}C < T_A < 125^{\circ}C$ for the UC1708,

$-25^{\circ}C < T_A < 85^{\circ}C$ for the UC2708, and $0^{\circ}C < T_A < 70^{\circ}C$ for the UC3708, $T_A = T_J$

PARAMETER		TEST CONDITIONS	MIN	TYP	MAX	UNIT
V_{IN}	Supply current	Outputs low		18	26	mA
		Outputs high		14	18	
		Enable = 0 V		1	4	
	A, B and shutdown inputs low level				0.8	V
	A, B and shutdown inputs high level		2.0			V
	A, B Input current low	$V_{A,B} = 0.4V$	-1	-0.6		mA
	A, B Input current high	$V_{A,B} = 2.4V$	-200		50	A
	A, B Input leakage current high	$V_{A,B} = 35.3V$			200	A
	Shutdown input current low	$V_{SHUTDOWN} = 0.4V$		20	100	A
	Shutdown input current high	$V_{SHUTDOWN} = 2.4V$		170	500	A
		$V_{SHUTDOWN} = 6.2V$		0.6	1.5	mA
	Enable input current low	$V_{ENABLE} = 0V$	-600	-460	200	A
	Enable input current high	$V_{ENABLE} = 6.2V$			200	A
	Enable threshold rising			2.8	3.6	V
	Enable threshold falling		1.0	2.4	3.4	V
$V_{IN} - V_{OUT}$	Output High Saturation	$I_{OUT} = -50mA$			2.0	V
		$I_{OUT} = -500mA$			2.5	V
V_{OUT}	Output Low Saturation	$I_{OUT} = 50mA$			0.5	V
		$I_{OUT} = 500mA$			2.5	V
	Thermal Shutdown			155		°C

SWITCHING CHARACTERISTICS (see Figure 1)

(VIN = 20V, delays measured to 10% output change.)

PARAMETER	TEST CONDITIONS		MIN	TYP	MAX	UNIT
FROM A,B INPUT TO OUTPUT:						
Rise Time Delay (TPLH)	CL = 0pF			25	40	ns
	CL = 1000pF	UC1708		25	45	ns
		UC2708/UC3708		25	40	
	CL = 2200pF	UC1708		25	50	ns
		UC2708/UC3708		25	45	
	10% to 90% Rise (TTLH)	CL = 0pF			55	75
CL = 1000pF ⁽¹⁾		UC1708		25	80	ns
		UC2708/UC3708		25	50	
CL = 2200pF		UC1708		40	85	ns
		UC2708/UC3708		40	55	
Fall Time Delay (TPHL)		CL = 0pF			25	40
	CL = 1000pF ⁽¹⁾			25	45	
	CL = 2200pF			35	50	
90% to 10% Fall (TTHL)	CL = 0pF			15	20	ns
	CL = 1000pF ⁽¹⁾			25	45	
	CL = 2200pF			40	55	

(1) These parameters, specified at 1000pF, although ensured over recommended operating conditions, are not tested in production.

SWITCHING CHARACTERISTICS (see Figure 1)

(VIN = 20V, delays measured to 10% output change.)

PARAMETER	TEST CONDITIONS		MIN	TYP	MAX	UNIT
FROM SHUTDOWN INPUT TO OUTPUT:						
Rise Time Delay (TPLH)	CL = 0pF			25	75	ns
	CL = 1000pF ⁽¹⁾	UC1708		30	80	ns
		UC2708/UC3708		30	75	
	CL = 2200pF	UC1708		35	85	ns
		UC2708/UC3708		35	75	
	10% to 90% Rise (TTLH)	CL = 0pF			50	75
CL = 1000pF ⁽¹⁾		UC1708		25	80	ns
		UC2708/UC3708		25	50	
CL = 2200pF		UC1708		40	85	ns
		UC2708/UC3708		40	55	
Fall Time Delay (TPHL)		CL = 0pF			25	45
	CL = 1000pF ⁽¹⁾			30	50	
	CL = 2200pF			35	55	
90% to 10% Fall (TTHL)	CL = 0pF			25	20	ns
	CL = 1000pF ⁽¹⁾			25	45	
	CL = 2200pF			40	55	
Total Supply Current	F = 200kHz, 50% duty cycle, both channels; CL = 0pF			23	25	mA
	F = 200kHz, 50% duty cycle, both channels; CL = 2200pF			38	45	

(1) These parameters, specified at 1000pF, although ensured over recommended operating conditions, are not tested in production.

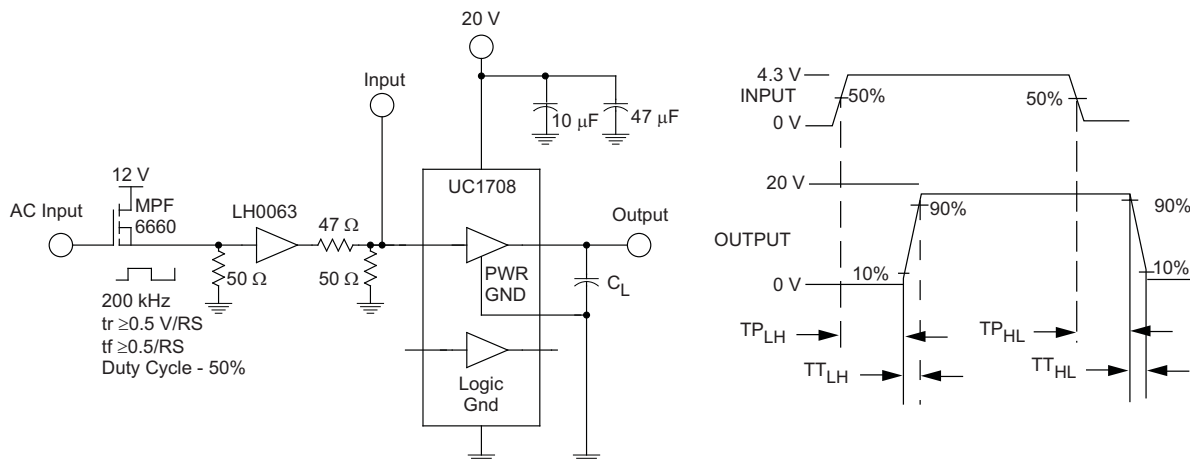
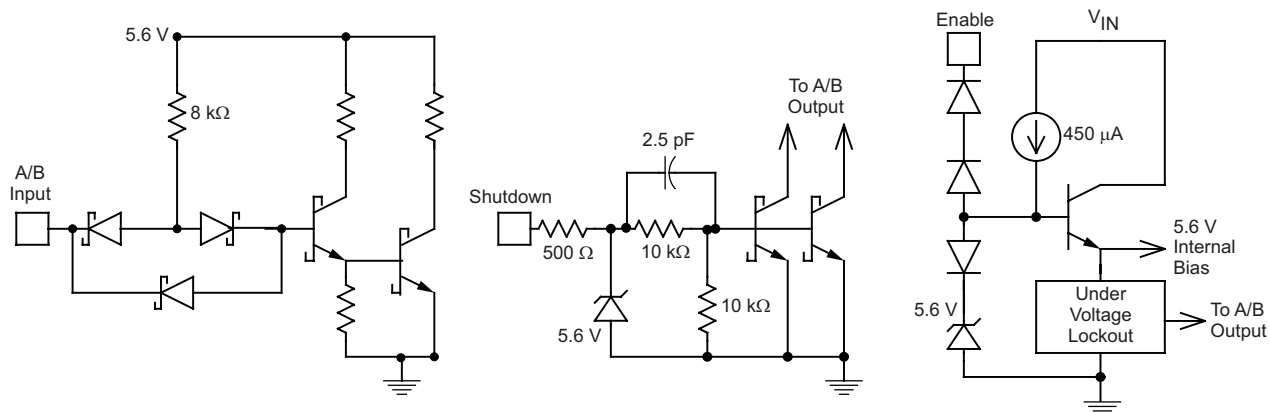

Figure 1. AC Test Circuit and Switching Time Waveforms



NOTE: Shutdown feature available only in JE, NE or DW Packages.

Figure 2. Equivalent Input Circuits

PACKAGING INFORMATION

Orderable Device	Status (1)	Package Type	Package Drawing	Pins	Package Qty	Eco Plan (2)	Lead finish/ Ball material (6)	MSL Peak Temp (3)	Op Temp (°C)	Device Marking (4/5)	Samples
5962-0051401Q2A	ACTIVE	LCCC	FK	20	1	Non-RoHS & Green	SNPB	N / A for Pkg Type	-55 to 125	5962- 0051401Q2A UC1708L/ 883B	Samples
5962-0051401QEA	ACTIVE	CDIP	J	16	1	Non-RoHS & Green	SNPB	N / A for Pkg Type	-55 to 125	5962-0051401QE A UC1708JE/883B	Samples
5962-0051401QPA	ACTIVE	CDIP	JG	8	1	Non-RoHS & Green	SNPB	N / A for Pkg Type	-55 to 125	0051401QPA UC1708	Samples
5962-0051401V2A	ACTIVE	LCCC	FK	20	1	Non-RoHS & Green	SNPB	N / A for Pkg Type	-55 to 125	5962- 0051401V2A UC1708L QMLV	Samples
5962-0051401VEA	ACTIVE	CDIP	J	16	1	Non-RoHS & Green	SNPB	N / A for Pkg Type	-55 to 125	5962-0051401VE A UC1708JEQMLV	Samples
5962-0051401VPA	ACTIVE	CDIP	JG	8	1	Non-RoHS & Green	SNPB	N / A for Pkg Type	-55 to 125	0051401VPA UC1708	Samples
UC1708J	ACTIVE	CDIP	JG	8	1	Non-RoHS & Green	SNPB	N / A for Pkg Type	-55 to 125	UC1708J	Samples
UC1708J883B	ACTIVE	CDIP	JG	8	1	Non-RoHS & Green	SNPB	N / A for Pkg Type	-55 to 125	0051401QPA UC1708	Samples
UC1708JE	ACTIVE	CDIP	J	16	1	Non-RoHS & Green	SNPB	N / A for Pkg Type	-55 to 125	UC1708JE	Samples
UC1708JE883B	ACTIVE	CDIP	J	16	1	Non-RoHS & Green	SNPB	N / A for Pkg Type	-55 to 125	5962-0051401QE A UC1708JE/883B	Samples
UC1708L883B	ACTIVE	LCCC	FK	20	1	Non-RoHS & Green	SNPB	N / A for Pkg Type	-55 to 125	5962- 0051401Q2A UC1708L/ 883B	Samples
UC2708DW	ACTIVE	SOIC	DW	16	40	RoHS & Green	NIPDAU	Level-2-260C-1 YEAR	-40 to 85	UC2708DW	Samples
UC2708DWTR	ACTIVE	SOIC	DW	16	2000	RoHS & Green	NIPDAU	Level-2-260C-1 YEAR	-40 to 85	UC2708DW	Samples

Orderable Device	Status (1)	Package Type	Package Drawing	Pins	Package Qty	Eco Plan (2)	Lead finish/ Ball material (6)	MSL Peak Temp (3)	Op Temp (°C)	Device Marking (4/5)	Samples
UC2708N	ACTIVE	PDIP	P	8	50	RoHS & Green	NIPDAU	N / A for Pkg Type	-40 to 85	UC2708N	Samples
UC3708DW	ACTIVE	SOIC	DW	16	40	RoHS & Green	NIPDAU	Level-2-260C-1 YEAR	0 to 70	UC3708DW	Samples
UC3708DWG4	ACTIVE	SOIC	DW	16	40	RoHS & Green	NIPDAU	Level-2-260C-1 YEAR	0 to 70	UC3708DW	Samples
UC3708DWTR	ACTIVE	SOIC	DW	16	2000	RoHS & Green	NIPDAU	Level-2-260C-1 YEAR	0 to 70	UC3708DW	Samples
UC3708N	ACTIVE	PDIP	P	8	50	RoHS & Green	NIPDAU	N / A for Pkg Type	0 to 70	UC3708N	Samples
UC3708NE	ACTIVE	PDIP	N	16	25	RoHS & Green	NIPDAU	N / A for Pkg Type	0 to 70	UC3708NE	Samples
UC3708NG4	ACTIVE	PDIP	P	8	50	RoHS & Green	NIPDAU	N / A for Pkg Type	0 to 70	UC3708N	Samples

(1) The marketing status values are defined as follows:

ACTIVE: Product device recommended for new designs.

LIFEBUY: TI has announced that the device will be discontinued, and a lifetime-buy period is in effect.

NRND: Not recommended for new designs. Device is in production to support existing customers, but TI does not recommend using this part in a new design.

PREVIEW: Device has been announced but is not in production. Samples may or may not be available.

OBSOLETE: TI has discontinued the production of the device.

(2) **RoHS:** TI defines "RoHS" to mean semiconductor products that are compliant with the current EU RoHS requirements for all 10 RoHS substances, including the requirement that RoHS substance do not exceed 0.1% by weight in homogeneous materials. Where designed to be soldered at high temperatures, "RoHS" products are suitable for use in specified lead-free processes. TI may reference these types of products as "Pb-Free".

RoHS Exempt: TI defines "RoHS Exempt" to mean products that contain lead but are compliant with EU RoHS pursuant to a specific EU RoHS exemption.

Green: TI defines "Green" to mean the content of Chlorine (Cl) and Bromine (Br) based flame retardants meet JS709B low halogen requirements of <=1000ppm threshold. Antimony trioxide based flame retardants must also meet the <=1000ppm threshold requirement.

(3) MSL, Peak Temp. - The Moisture Sensitivity Level rating according to the JEDEC industry standard classifications, and peak solder temperature.

(4) There may be additional marking, which relates to the logo, the lot trace code information, or the environmental category on the device.

(5) Multiple Device Markings will be inside parentheses. Only one Device Marking contained in parentheses and separated by a "~" will appear on a device. If a line is indented then it is a continuation of the previous line and the two combined represent the entire Device Marking for that device.

(6) Lead finish/Ball material - Orderable Devices may have multiple material finish options. Finish options are separated by a vertical ruled line. Lead finish/Ball material values may wrap to two lines if the finish value exceeds the maximum column width.

Important Information and Disclaimer: The information provided on this page represents TI's knowledge and belief as of the date that it is provided. TI bases its knowledge and belief on information provided by third parties, and makes no representation or warranty as to the accuracy of such information. Efforts are underway to better integrate information from third parties. TI has taken and continues to take reasonable steps to provide representative and accurate information but may not have conducted destructive testing or chemical analysis on incoming materials and chemicals. TI and TI suppliers consider certain information to be proprietary, and thus CAS numbers and other limited information may not be available for release.

In no event shall TI's liability arising out of such information exceed the total purchase price of the TI part(s) at issue in this document sold by TI to Customer on an annual basis.

OTHER QUALIFIED VERSIONS OF UC1708, UC1708-SP, UC3708 :

- Catalog : [UC3708](#), [UC1708](#)

- Military : [UC1708](#)

- Space : [UC1708-SP](#)

NOTE: Qualified Version Definitions:

- Catalog - TI's standard catalog product

- Military - QML certified for Military and Defense Applications

- Space - Radiation tolerant, ceramic packaging and qualified for use in Space-based application

TAPE AND REEL INFORMATION

QUADRANT ASSIGNMENTS FOR PIN 1 ORIENTATION IN TAPE

*All dimensions are nominal

Device	Package Type	Package Drawing	Pins	SPQ	Reel Diameter (mm)	Reel Width W1 (mm)	A0 (mm)	B0 (mm)	K0 (mm)	P1 (mm)	W (mm)	Pin1 Quadrant
UC2708DWTR	SOIC	DW	16	2000	330.0	16.4	10.75	10.7	2.7	12.0	16.0	Q1
UC3708DWTR	SOIC	DW	16	2000	330.0	16.4	10.75	10.7	2.7	12.0	16.0	Q1

TAPE AND REEL BOX DIMENSIONS

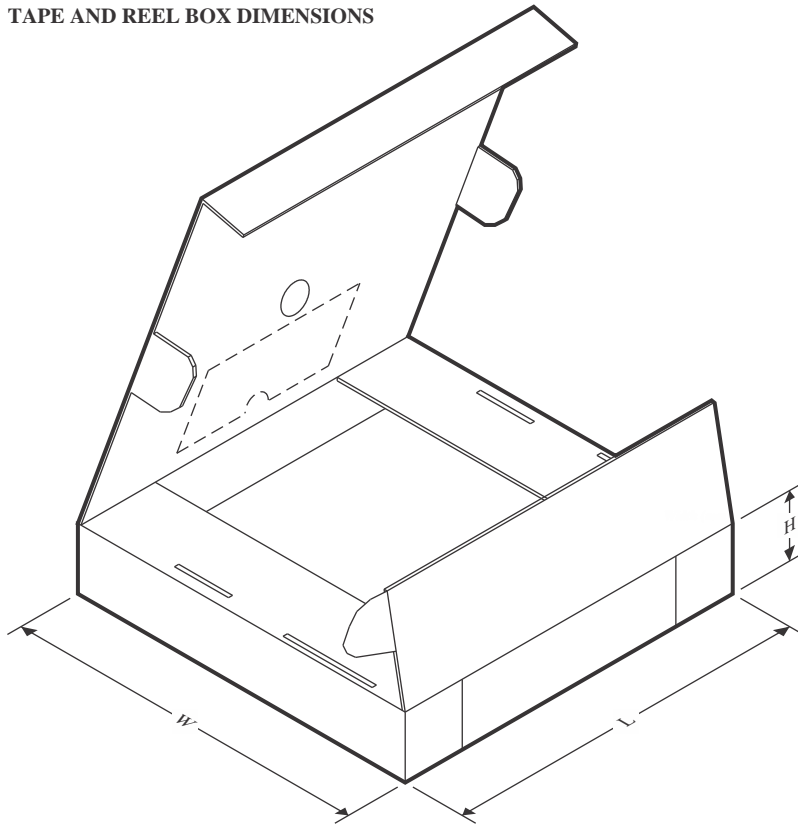

*All dimensions are nominal

Device	Package Type	Package Drawing	Pins	SPQ	Length (mm)	Width (mm)	Height (mm)
UC2708DWTR	SOIC	DW	16	2000	356.0	356.0	35.0
UC3708DWTR	SOIC	DW	16	2000	356.0	356.0	35.0

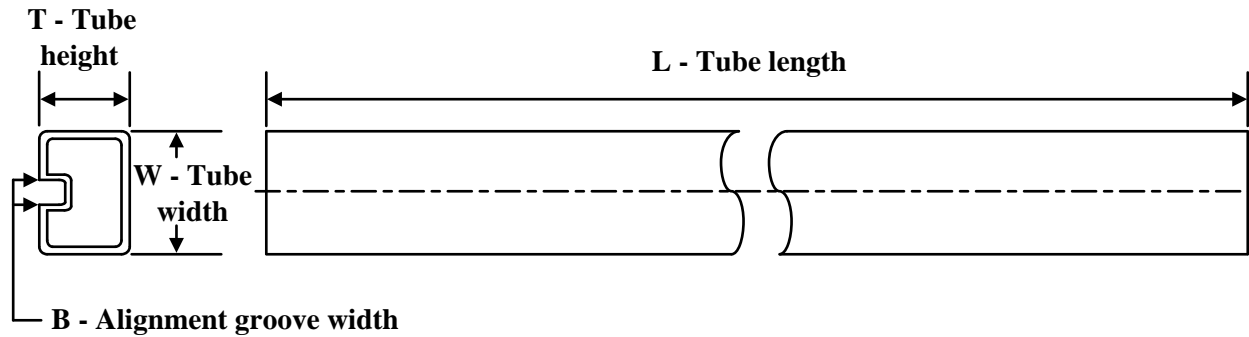
TUBE

*All dimensions are nominal

Device	Package Name	Package Type	Pins	SPQ	L (mm)	W (mm)	T (μm)	B (mm)
5962-0051401Q2A	FK	LCCC	20	1	506.98	12.06	2030	NA
5962-0051401V2A	FK	LCCC	20	1	506.98	12.06	2030	NA
UC1708L883B	FK	LCCC	20	1	506.98	12.06	2030	NA
UC2708DW	DW	SOIC	16	40	507	12.83	5080	6.6
UC2708N	P	PDIP	8	50	506	13.97	11230	4.32
UC3708DW	DW	SOIC	16	40	507	12.83	5080	6.6
UC3708DWG4	DW	SOIC	16	40	507	12.83	5080	6.6
UC3708N	P	PDIP	8	50	506	13.97	11230	4.32
UC3708NE	N	PDIP	16	25	506	13.97	11230	4.32
UC3708NG4	P	PDIP	8	50	506	13.97	11230	4.32

GENERIC PACKAGE VIEW

DW 16

SOIC - 2.65 mm max height

7.5 x 10.3, 1.27 mm pitch

SMALL OUTLINE INTEGRATED CIRCUIT

This image is a representation of the package family, actual package may vary.
Refer to the product data sheet for package details.

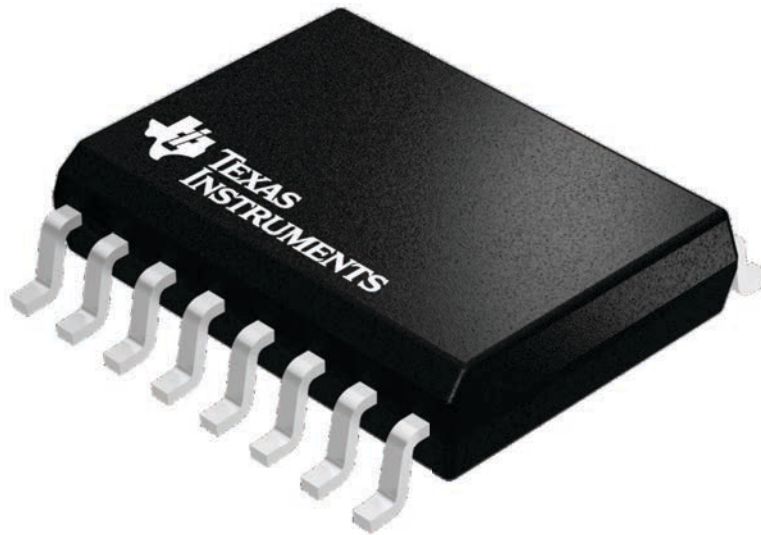

4224780/A

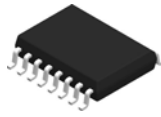

DW0016A

PACKAGE OUTLINE SOIC - 2.65 mm max height

SOIC

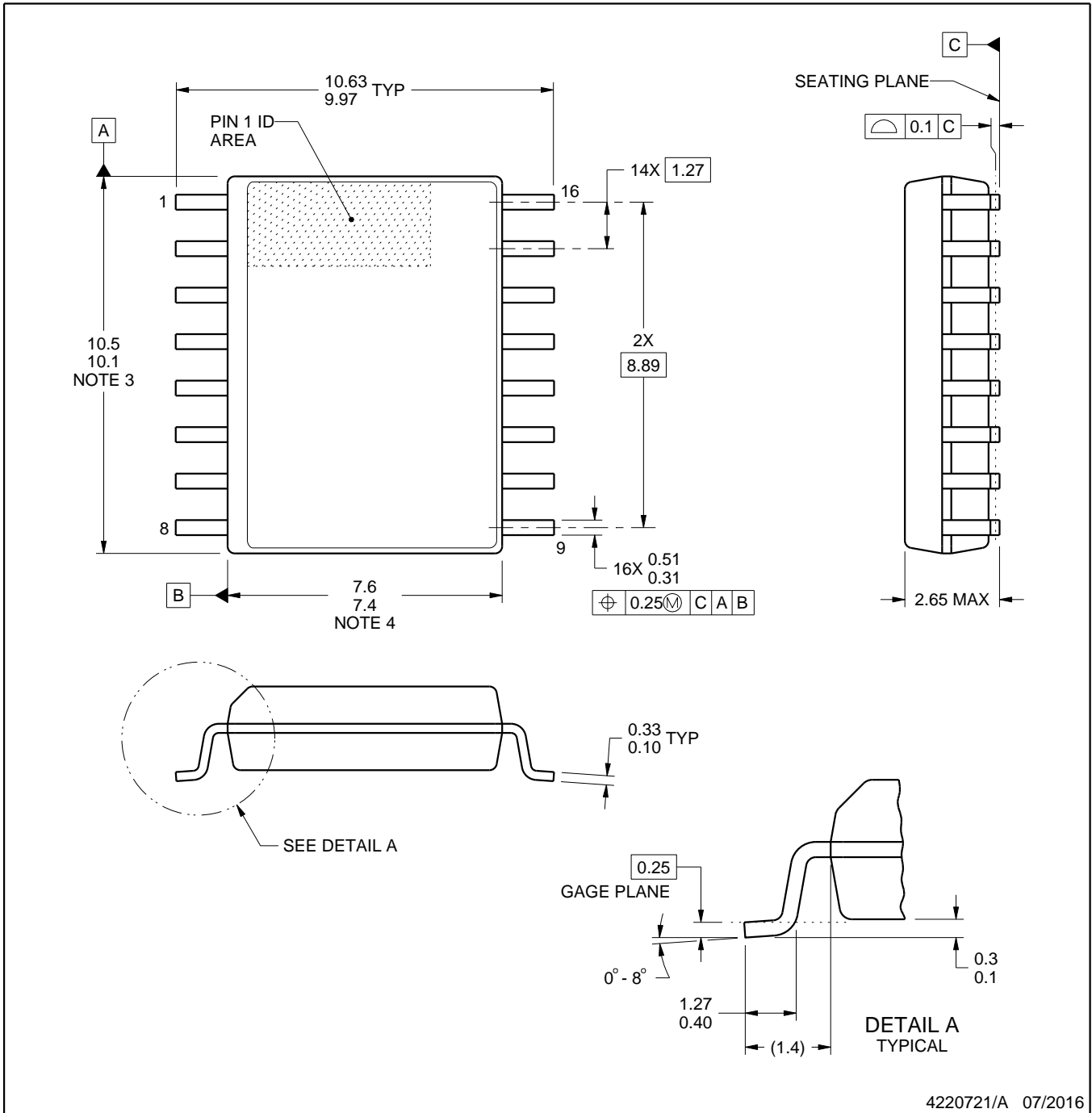

4220721/A 07/2016

NOTES:

1. All linear dimensions are in millimeters. Dimensions in parenthesis are for reference only. Dimensioning and tolerancing per ASME Y14.5M.
2. This drawing is subject to change without notice.
3. This dimension does not include mold flash, protrusions, or gate burrs. Mold flash, protrusions, or gate burrs shall not exceed 0.15 mm, per side.
4. This dimension does not include interlead flash. Interlead flash shall not exceed 0.25 mm, per side.
5. Reference JEDEC registration MS-013.

EXAMPLE BOARD LAYOUT

DW0016A

SOIC - 2.65 mm max height

SOIC

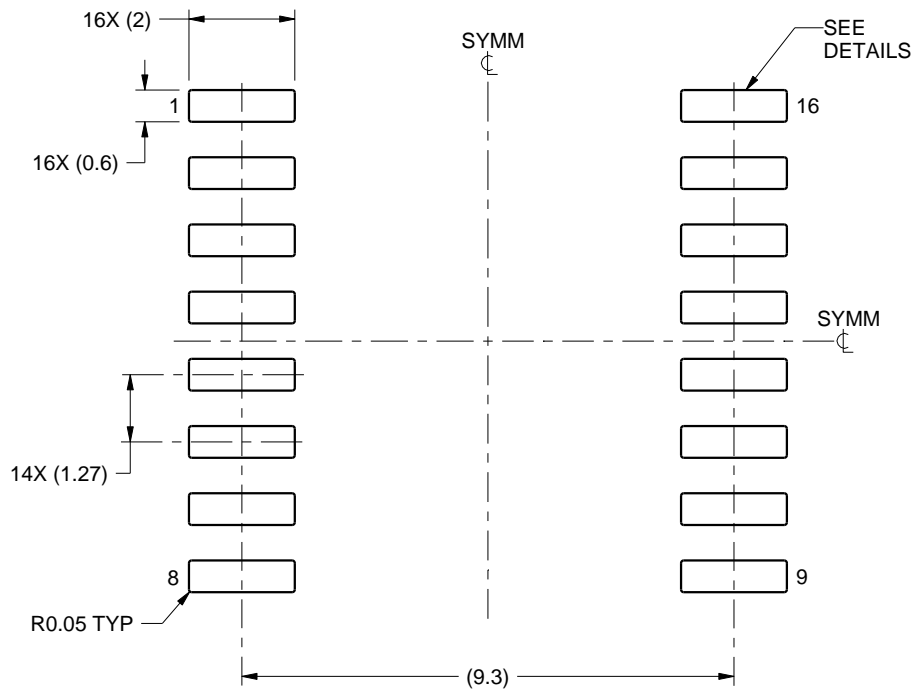

LAND PATTERN EXAMPLE
SCALE:7X

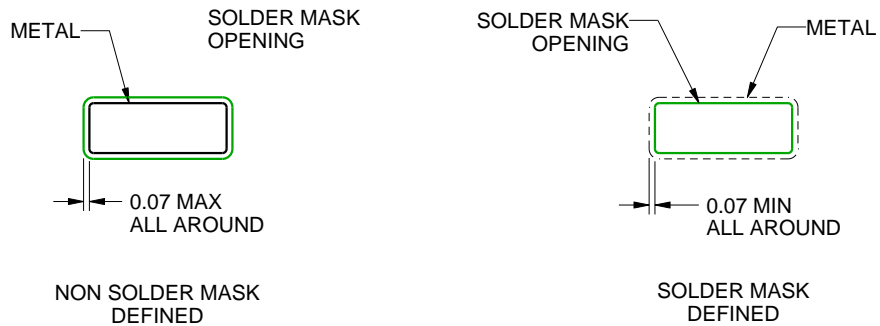

SOLDER MASK DETAILS

4220721/A 07/2016

NOTES: (continued)

6. Publication IPC-7351 may have alternate designs.

7. Solder mask tolerances between and around signal pads can vary based on board fabrication site.

EXAMPLE STENCIL DESIGN

DW0016A

SOIC - 2.65 mm max height

SOIC

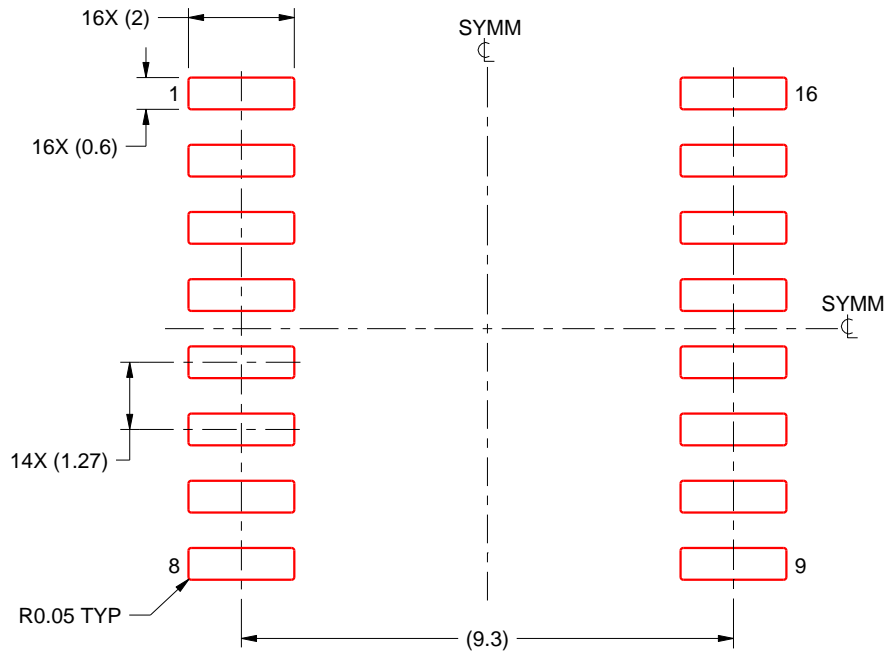

SOLDER PASTE EXAMPLE
BASED ON 0.125 mm THICK STENCIL
SCALE:7X

4220721/A 07/2016

NOTES: (continued)

8. Laser cutting apertures with trapezoidal walls and rounded corners may offer better paste release. IPC-7525 may have alternate design recommendations.
9. Board assembly site may have different recommendations for stencil design.

J (R-GDIP-T**)

14 LEADS SHOWN

CERAMIC DUAL IN-LINE PACKAGE



DIM \ PINS **	14	16	18	20
A	0.300 (7,62) BSC	0.300 (7,62) BSC	0.300 (7,62) BSC	0.300 (7,62) BSC
B MAX	0.785 (19,94)	.840 (21,34)	0.960 (24,38)	1.060 (26,92)
B MIN	—	—	—	—
C MAX	0.300 (7,62)	0.300 (7,62)	0.310 (7,87)	0.300 (7,62)
C MIN	0.245 (6,22)	0.245 (6,22)	0.220 (5,59)	0.245 (6,22)



4040083/F 03/03

- NOTES:
- All linear dimensions are in inches (millimeters).
 - This drawing is subject to change without notice.
 - This package is hermetically sealed with a ceramic lid using glass frit.
 - Index point is provided on cap for terminal identification only on press ceramic glass frit seal only.
 - Falls within MIL STD 1835 GDIP1-T14, GDIP1-T16, GDIP1-T18 and GDIP1-T20.

JG (R-GDIP-T8)

CERAMIC DUAL-IN-LINE

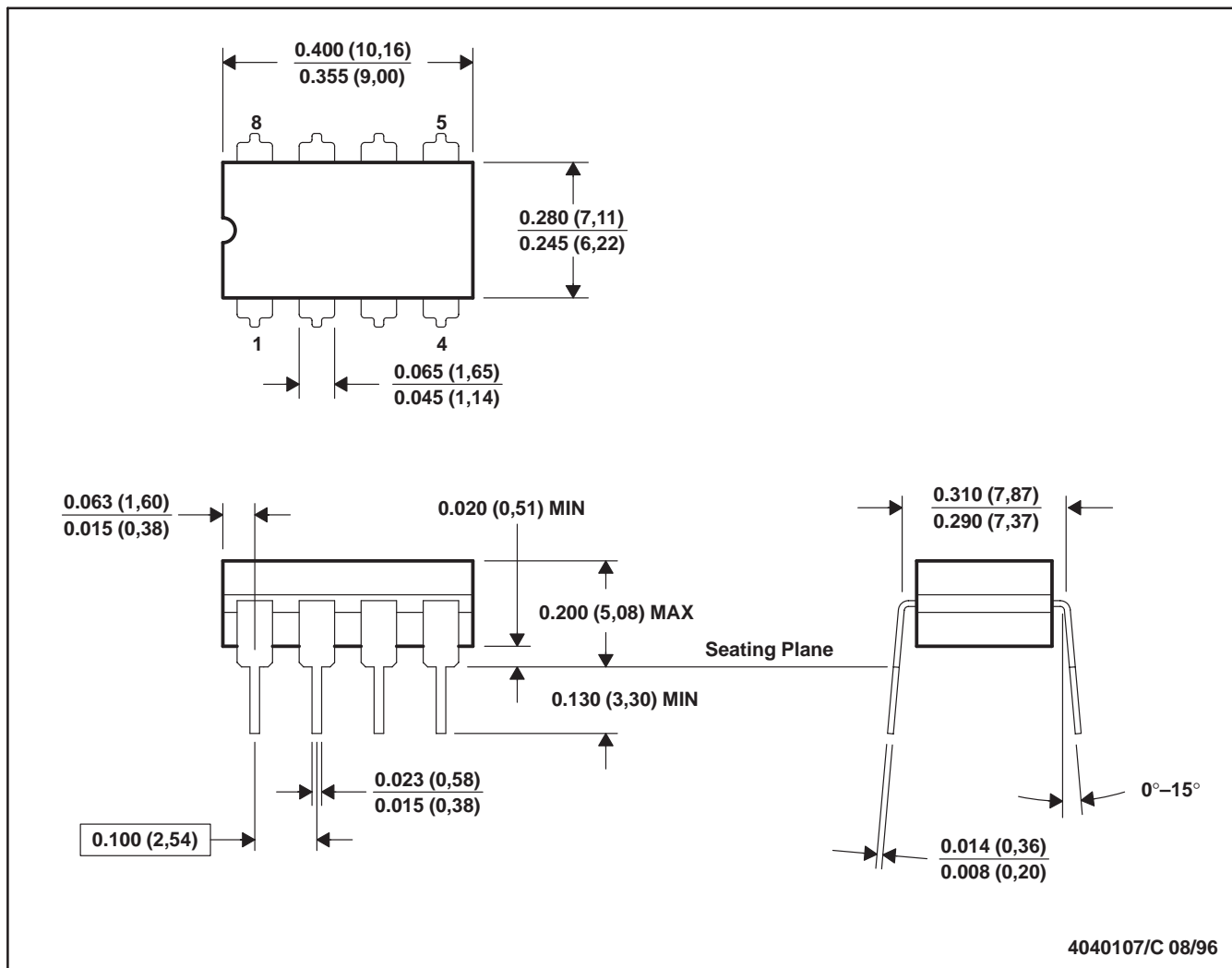

- NOTES: A. All linear dimensions are in inches (millimeters).
 B. This drawing is subject to change without notice.
 C. This package can be hermetically sealed with a ceramic lid using glass frit.
 D. Index point is provided on cap for terminal identification.
 E. Falls within MIL STD 1835 GDIP1-T8

P (R-PDIP-T8)

PLASTIC DUAL-IN-LINE PACKAGE

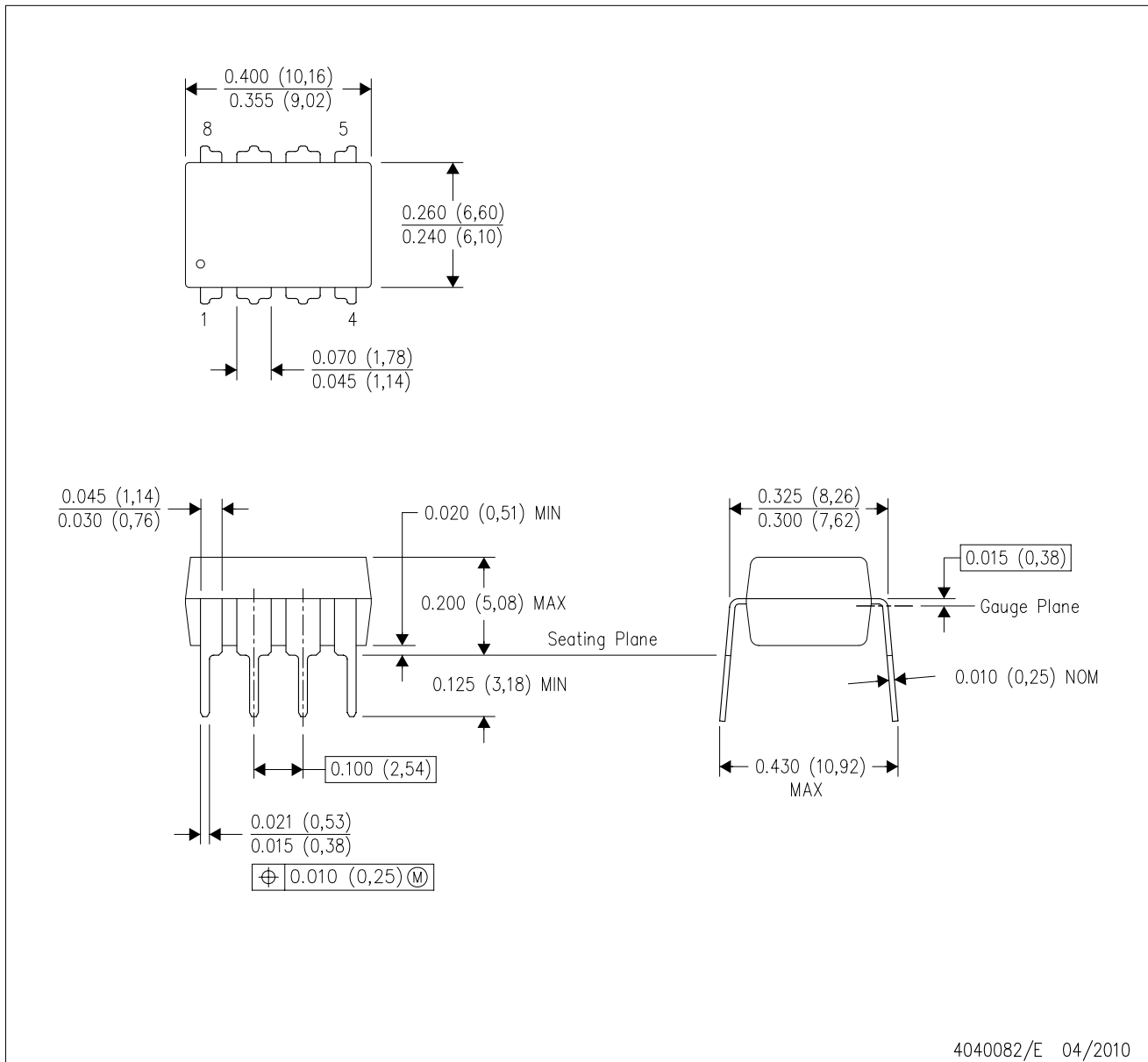

4040082/E 04/2010

- NOTES:
- A. All linear dimensions are in inches (millimeters).
 - B. This drawing is subject to change without notice.
 - C. Falls within JEDEC MS-001 variation BA.

N (R-PDIP-T**)

PLASTIC DUAL-IN-LINE PACKAGE

16 PINS SHOWN



- NOTES:
- A. All linear dimensions are in inches (millimeters).
 - B. This drawing is subject to change without notice.
 - C. Falls within JEDEC MS-001, except 18 and 20 pin minimum body length (Dim A).
 - D. The 20 pin end lead shoulder width is a vendor option, either half or full width.

FK (S-CQCC-N**)

LEADLESS CERAMIC CHIP CARRIER

28 TERMINAL SHOWN



NO. OF TERMINALS **	A		B	
	MIN	MAX	MIN	MAX
20	0.342 (8,69)	0.358 (9,09)	0.307 (7,80)	0.358 (9,09)
28	0.442 (11,23)	0.458 (11,63)	0.406 (10,31)	0.458 (11,63)
44	0.640 (16,26)	0.660 (16,76)	0.495 (12,58)	0.560 (14,22)
52	0.740 (18,78)	0.761 (19,32)	0.495 (12,58)	0.560 (14,22)
68	0.938 (23,83)	0.962 (24,43)	0.850 (21,6)	0.858 (21,8)
84	1.141 (28,99)	1.165 (29,59)	1.047 (26,6)	1.063 (27,0)



4040140/D 01/11

- NOTES:
- All linear dimensions are in inches (millimeters).
 - This drawing is subject to change without notice.
 - This package can be hermetically sealed with a metal lid.
 - Falls within JEDEC MS-004

IMPORTANT NOTICE AND DISCLAIMER

TI PROVIDES TECHNICAL AND RELIABILITY DATA (INCLUDING DATA SHEETS), DESIGN RESOURCES (INCLUDING REFERENCE DESIGNS), APPLICATION OR OTHER DESIGN ADVICE, WEB TOOLS, SAFETY INFORMATION, AND OTHER RESOURCES "AS IS" AND WITH ALL FAULTS, AND DISCLAIMS ALL WARRANTIES, EXPRESS AND IMPLIED, INCLUDING WITHOUT LIMITATION ANY IMPLIED WARRANTIES OF MERCHANTABILITY, FITNESS FOR A PARTICULAR PURPOSE OR NON-INFRINGEMENT OF THIRD PARTY INTELLECTUAL PROPERTY RIGHTS.

These resources are intended for skilled developers designing with TI products. You are solely responsible for (1) selecting the appropriate TI products for your application, (2) designing, validating and testing your application, and (3) ensuring your application meets applicable standards, and any other safety, security, regulatory or other requirements.

These resources are subject to change without notice. TI grants you permission to use these resources only for development of an application that uses the TI products described in the resource. Other reproduction and display of these resources is prohibited. No license is granted to any other TI intellectual property right or to any third party intellectual property right. TI disclaims responsibility for, and you will fully indemnify TI and its representatives against, any claims, damages, costs, losses, and liabilities arising out of your use of these resources.

TI's products are provided subject to [TI's Terms of Sale](#) or other applicable terms available either on ti.com or provided in conjunction with such TI products. TI's provision of these resources does not expand or otherwise alter TI's applicable warranties or warranty disclaimers for TI products.

TI objects to and rejects any additional or different terms you may have proposed.

Mailing Address: Texas Instruments, Post Office Box 655303, Dallas, Texas 75265
Copyright © 2022, Texas Instruments Incorporated