

## 双 5A 高速低侧栅极驱动器

 查询样品: [UCC27523](#), [UCC27524](#), [UCC27525](#), [UCC27526](#)

### 特性

- 工业标准引脚分配
- 两个独立的栅极驱动通道
- **5A** 峰值驱动源电流和灌电流
- 针对每个输出的独立使能功能
- 与电源电压无关的 **TTL** 和 **CMOS** 兼容逻辑阈值
- 针对高抗扰度的滞后逻辑阈值
- 输入和使能引脚电压电平不受 **VDD** 引脚偏置电源电压限制
- **4.5V** 至 **18V** 单电源范围
- 在 **VDD** 欠压闭锁 (**UVLO**) 期间, 输出保持低电平, (以确保加电和断电时的无毛刺脉冲运行)
- 快速传播延迟 (典型值 **13ns**)
- 快速上升和下降时间 (典型值 **7ns** 和 **6ns**)
- 两通道间典型值为 **1ns** 的延迟匹配时间
- 针对更高的驱动电流, 两个输出可以并联
- 当输入悬空时输出保持在低电平
- 环氧树脂双列直插式 (**PDIP**)-8, 小外形尺寸集成电路 (**SOIC**)-8, 表面贴装小外形尺寸 (**MSOP**)-8 封装 **PowerPAD™** 和 **3mm x 3mm** 超薄型小外形尺寸 (**WSON**)-8 封装选项
- **-40°C** 至 **+140°C** 的运行温度范围

### 应用范围

- 开关模式电源
- 直流 (**DC**) 到 **DC** 转换器
- 电机控制, 太阳能
- 用于诸如 **GaN** 等新上市的宽带隙电源器件的栅极驱动器

### 说明

UCC2752x 系列器件是双通道、高速、低侧栅极驱动器, 此器件能够有效地驱动 MOSFET 和绝缘栅极型功率管 (IGBT) 电源开关。使用能够从内部大大降低击穿电流的设计, UCC2752x 能够将高达 **5A** 拉电流和 **5A** 灌电流的高峰值电流脉传送到电容负载, 此器件还具有轨到轨驱动能力和典型值为 **13ns** 的极小传播延迟。除此之外, 此驱动器特有两个通道间相匹配的内部传播延迟, 这一特性使得此驱动器非常适合于诸如同步整流器等对于双栅极驱动有严格计时要求的应用。这还使得两个通道可以并联, 以有效地增加电流驱动能力或者使用一个单一输入信号驱动两个并联在一起的开关。输入引脚阈值基于 **TTL** 和 **CMOS** 兼容低压逻辑, 此逻辑是固定的并且与 **VDD** 电源电压无关。高低阈值间的宽滞后提供了出色的抗扰度。

### 产品矩阵

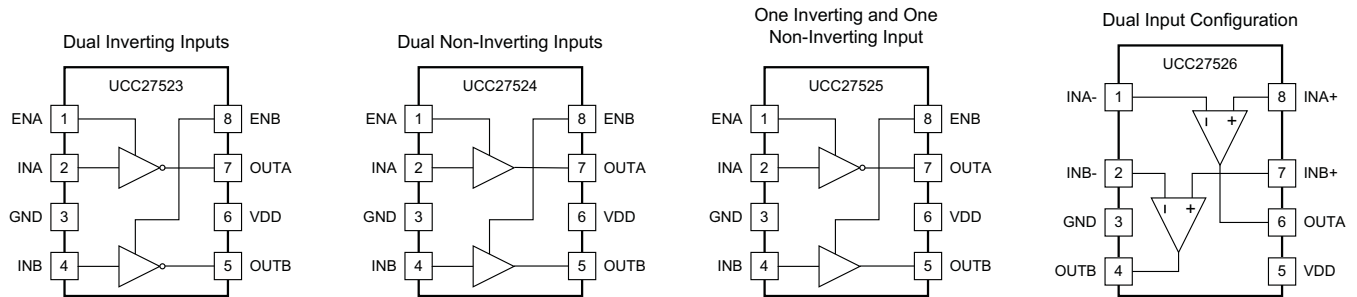

Please be aware that an important notice concerning availability, standard warranty, and use in critical applications of Texas Instruments semiconductor products and disclaimers thereto appears at the end of this data sheet.

PowerPAD is a trademark of Texas Instruments.

PRODUCTION DATA information is current as of publication date. Products conform to specifications per the terms of the Texas Instruments standard warranty. Production processing does not necessarily include testing of all parameters.

版权 © 2011–2013, Texas Instruments Incorporated  
English Data Sheet: [SLUSAQ3](#)



这些装置包含有限的内置 ESD 保护。

存储或装卸时，应将导线一起截短或将装置放置于导电泡棉中，以防止 MOS 门极遭受静电损伤。

## 说明（继续）

UCC2752x 系列产品提供了三个标准逻辑选项的组合-双路反相，双路非反相，一路反相和一路非反相驱动器。UCC27526 特有一个双输入设计，此设计为每个通道提供了反相（IN- 引脚）和非反相（IN+ 引脚）配置的灵活性。IN+ 或 IN- 引脚中的任何一个控制驱动器输出状态。未使用的输入引脚可被用于启用和禁用功能。出于安全的考虑，UCC2752x 系列内所有器件输入引脚上的内部上拉和下拉电阻器可在输入引脚处于悬空条件下时确保输出保持低电平。为了更好地控制驱动器应用的运行，UCC27323, UCC27324 和 UCC27325 均特有一个使能引脚（ENA 和 ENB）。针对高电平有效逻辑，这些引脚被内部上拉至 VDD 并可针对标准运行而保持断开。

UCC2752x 系列器件采用 SOIC-8(D)，带有外露焊垫的 MSOP-8(DGN) 和带有外露焊垫的 3mm x 3mm WSON-8(DSD) 封装。UCC27524 也可采用 PDIP-8(P) 封装。对于 UCC27526，只提供 3mm x 3mm WSON(DSD) 封装。

### ORDERING INFORMATION<sup>(1)(2)</sup>

PART NUMBER	PACKAGE	OPERATING TEMPERATURE RANGE, T <sub>A</sub>
UCC27523	SOIC 8-Pin (D), MSOP 8-pin (DGN), WSON 8-pin (DSD)	-40°C to 140°C
UCC27524	SOIC 8-Pin (D), MSOP 8-pin (DGN), WSON 8-pin (DSD), PDIP 8-pin (P)	
UCC27525	SOIC 8-Pin (D), MSOP 8-pin (DGN), WSON 8-pin (DSD)	
UCC27526	WSON 8-pin (DSD)	

- (1) For the most current package and ordering information, see Package Option Addendum at the end of this document.  
 (2) All packages use Pb-Free lead finish of Pd-Ni-Au which is compatible with MSL level 1 at 255°C to 260°C peak reflow temperature to be compatible with either lead free or Sn/Pb soldering operations. DSD package is rated MSL level 2.

### TOPSIDE MARKING INFORMATION

PART NUMBER WITH PACKAGE DESIGNATOR	TOP MARKINGS
UCC27524D	27524
UCC27524DGN	27524
UCC27524DSD	SBA
UCC27524P	27524
UCC27523D	27523
UCC27523DGN	27523
UCC27523DSD	27523
UCC27525D	27525
UCC27525DGN	27525
UCC27525DSD	27525
UCC27526DSD	SCB

**ABSOLUTE MAXIMUM RATINGS<sup>(1)(2)</sup>**

over operating free-air temperature range (unless otherwise noted)

		MIN	MAX	UNIT
Supply voltage range	VDD	-0.3 to	20.0	V
OUTA, OUTB voltage	DC	-0.3 to	VDD + 0.3	
	Repetitive pulse < 200 ns <sup>(3)</sup>	-2.0 to	VDD + 0.3	
Output continuous source/sink current	I <sub>OUT_DC</sub>		0.3	A
Output pulsed source/sink current (0.5 μs)	I <sub>OUT_pulsed</sub>		5	
INA, INB, INA+, INA-, INB+, INB-, ENA, ENB voltage <sup>(4)</sup>		-0.3	20	V
ESD <sup>(5)</sup>	Human body model, HBM		4000	
	Charge device model, CDM		1000	
Operating virtual junction temperature, T <sub>J</sub> range		-40	150	°C
Storage temperature range, T <sub>stg</sub>		-65	150	
Lead temperature	Soldering, 10 sec.		300	
	Reflow		260	

- (1) Stresses beyond those listed under *absolute maximum ratings* may cause permanent damage to the device. These are stress ratings only and functional operation of the device at these or any other conditions beyond those indicated under *recommended operating conditions* is not implied. Exposure to absolute-maximum-rated conditions for extended periods may affect device reliability.
- (2) All voltages are with respect to GND unless otherwise noted. Currents are positive into, negative out of the specified terminal. See Packaging Section of the datasheet for thermal limitations and considerations of packages.
- (3) Values are verified by characterization on bench.
- (4) The maximum voltage on the Input and Enable pins is not restricted by the voltage on the VDD pin.
- (5) These devices are sensitive to electrostatic discharge; follow proper device handling procedures.

**RECOMMENDED OPERATING CONDITIONS**

over operating free-air temperature range (unless otherwise noted)

	MIN	TYP	MAX	UNIT
Supply voltage range, VDD	4.5	12	18	V
Operating junction temperature range	-40		140	°C
Input voltage, INA, INB, INA+, INA-, INB+, INB-	0		18	V
Enable voltage, ENA and ENB	0		18	

**THERMAL INFORMATION**

THERMAL METRIC		UCC27523, UCC27524, UCC27525	UCC27523, UCC27524, UCC27525	UNITS
		SOIC (D)	MSOP (DGN) <sup>(1)</sup>	
		8 PINS	8 PINS	
$\theta_{JA}$	Junction-to-ambient thermal resistance <sup>(2)</sup>	130.9	71.8	°C/W
$\theta_{JCTop}$	Junction-to-case (top) thermal resistance <sup>(3)</sup>	80.0	65.6	
$\theta_{JB}$	Junction-to-board thermal resistance <sup>(4)</sup>	71.4	7.4	
$\psi_{JT}$	Junction-to-top characterization parameter <sup>(5)</sup>	21.9	7.4	
$\psi_{JB}$	Junction-to-board characterization parameter <sup>(6)</sup>	70.9	31.5	
$\theta_{JCbott}$	Junction-to-case (bottom) thermal resistance <sup>(7)</sup>	n/a	19.6	

- (1) For more information about traditional and new thermal metrics, see the *IC Package Thermal Metrics* application report, [SPRA953](#).
- (2) The junction-to-ambient thermal resistance under natural convection is obtained in a simulation on a JEDEC-standard, high-K board, as specified in JESD51-7, in an environment described in JESD51-2a.
- (3) The junction-to-case (top) thermal resistance is obtained by simulating a cold plate test on the package top. No specific JEDEC-standard test exists, but a close description can be found in the ANSI SEMI standard G30-88.
- (4) The junction-to-board thermal resistance is obtained by simulating in an environment with a ring cold plate fixture to control the PCB temperature, as described in JESD51-8.
- (5) The junction-to-top characterization parameter,  $\psi_{JT}$ , estimates the junction temperature of a device in a real system and is extracted from the simulation data for obtaining  $\theta_{JA}$ , using a procedure described in JESD51-2a (sections 6 and 7).
- (6) The junction-to-board characterization parameter,  $\psi_{JB}$ , estimates the junction temperature of a device in a real system and is extracted from the simulation data for obtaining  $\theta_{JA}$ , using a procedure described in JESD51-2a (sections 6 and 7).
- (7) The junction-to-case (bottom) thermal resistance is obtained by simulating a cold plate test on the exposed (power) pad. No specific JEDEC standard test exists, but a close description can be found in the ANSI SEMI standard G30-88.

**THERMAL INFORMATION**

THERMAL METRIC		UCC27524	UCC27523, UCC27524, UCC27525, UCC27526	UNITS
		PDIP (P)	WSON (DSD) <sup>(1)</sup>	
		8 PINS	8 PINS	
$\theta_{JA}$	Junction-to-ambient thermal resistance <sup>(2)</sup>	62.1	46.7	°C/W
$\theta_{JCTop}$	Junction-to-case (top) thermal resistance <sup>(3)</sup>	52.7	46.7	
$\theta_{JB}$	Junction-to-board thermal resistance <sup>(4)</sup>	39.1	22.4	
$\psi_{JT}$	Junction-to-top characterization parameter <sup>(5)</sup>	31.0	0.7	
$\psi_{JB}$	Junction-to-board characterization parameter <sup>(6)</sup>	39.1	22.6	
$\theta_{JCbott}$	Junction-to-case (bottom) thermal resistance <sup>(7)</sup>	n/a	9.5	

- (1) For more information about traditional and new thermal metrics, see the *IC Package Thermal Metrics* application report, [SPRA953](#).
- (2) The junction-to-ambient thermal resistance under natural convection is obtained in a simulation on a JEDEC-standard, high-K board, as specified in JESD51-7, in an environment described in JESD51-2a.
- (3) The junction-to-case (top) thermal resistance is obtained by simulating a cold plate test on the package top. No specific JEDEC-standard test exists, but a close description can be found in the ANSI SEMI standard G30-88.
- (4) The junction-to-board thermal resistance is obtained by simulating in an environment with a ring cold plate fixture to control the PCB temperature, as described in JESD51-8.
- (5) The junction-to-top characterization parameter,  $\psi_{JT}$ , estimates the junction temperature of a device in a real system and is extracted from the simulation data for obtaining  $\theta_{JA}$ , using a procedure described in JESD51-2a (sections 6 and 7).
- (6) The junction-to-board characterization parameter,  $\psi_{JB}$ , estimates the junction temperature of a device in a real system and is extracted from the simulation data for obtaining  $\theta_{JA}$ , using a procedure described in JESD51-2a (sections 6 and 7).
- (7) The junction-to-case (bottom) thermal resistance is obtained by simulating a cold plate test on the exposed (power) pad. No specific JEDEC standard test exists, but a close description can be found in the ANSI SEMI standard G30-88.

**ELECTRICAL CHARACTERISTICS**

$V_{DD} = 12\text{ V}$ ,  $T_A = T_J = -40^\circ\text{C}$  to  $140^\circ\text{C}$ , 1- $\mu\text{F}$  capacitor from  $V_{DD}$  to GND. Currents are positive into, negative out of the specified terminal (unless otherwise noted.)

PARAMETER		TEST CONDITION	MIN	TYP	MAX	UNITS
<b>Bias Currents</b>						
$I_{DD(\text{off})}$	Startup current, (based on UCC27524 Input configuration)	$V_{DD} = 3.4\text{ V}$ , $INA = V_{DD}$ , $INB = V_{DD}$	55	110	175	$\mu\text{A}$
		$V_{DD} = 3.4\text{ V}$ , $INA = \text{GND}$ , $INB = \text{GND}$	25	75	145	
<b>Under Voltage LockOut (UVLO)</b>						
$V_{ON}$	Supply start threshold	$T_J = 25^\circ\text{C}$	3.91	4.20	4.50	V
		$T_J = -40^\circ\text{C}$ to $140^\circ\text{C}$	3.70	4.20	4.65	
$V_{OFF}$	Minimum operating voltage after supply start		3.40	3.90	4.40	
$V_{DD\_H}$	Supply voltage hysteresis		0.20	0.30	0.50	
<b>Inputs (INA, INB, INA+, INA-, INB+, INB-), UCC2752X (D, DGN, DSD)</b>						
$V_{IN\_H}$	Input signal high threshold	Output high for non-inverting input pins Output low for inverting input pins	1.9	2.1	2.3	V
$V_{IN\_L}$	Input signal low threshold	Output low for non-inverting input pins Output high for inverting input pins	1.0	1.2	1.4	
$V_{IN\_HYS}$	Input hysteresis		0.70	0.90	1.10	
<b>INPUTS (INA, INB, INA+, INA-, INB+, INB-) UCC27524P ONLY</b>						
$V_{IN\_H}$	Input signal high threshold	Output high for non-inverting input pins Output low for inverting input pins			2.3	V
$V_{IN\_L}$	Input signal low threshold	Output low for non-inverting input pins Output high for inverting input pins	1.0			
$V_{IN\_HYS}$	Input hysteresis			0.9		
<b>Enable (ENA, ENB) UCC2752X (D, DGN, DSD)</b>						
$V_{EN\_H}$	Enable signal high threshold	Output enabled	1.9	2.1	2.3	V
$V_{EN\_L}$	Enable signal low threshold	Output disabled	0.95	1.15	1.35	
$V_{EN\_HYS}$	Enable hysteresis		0.70	0.95	1.10	
<b>ENABLE (ENA, ENB) UCC27524P ONLY</b>						
$V_{EN\_H}$	Enable signal high threshold	Output enabled			2.3	V
$V_{EN\_L}$	Enable signal low threshold	Output disabled	0.95			
$V_{EN\_HYS}$	Enable hysteresis			0.95		
<b>Outputs (OUTA, OUTB)</b>						
$I_{SNK/SRC}$	Sink/source peak current <sup>(1)</sup>	$C_{LOAD} = 0.22\ \mu\text{F}$ , $F_{SW} = 1\ \text{kHz}$		$\pm 5$		A
$V_{DD}-V_{OH}$	High output voltage	$I_{OUT} = -10\ \text{mA}$			0.075	V
$V_{OL}$	Low output voltage	$I_{OUT} = 10\ \text{mA}$			0.01	
$R_{OH}$	Output pullup resistance <sup>(2)</sup>	$I_{OUT} = -10\ \text{mA}$	2.5	5	7.5	$\Omega$
$R_{OL}$	Output pulldown resistance	$I_{OUT} = 10\ \text{mA}$	0.15	0.5	1	$\Omega$
<b>Switching Time</b>						

(1) Ensured by design.

(2)  $R_{OH}$  represents on-resistance of only the P-Channel MOSFET device in pullup structure of UCC2752X output stage.

**ELECTRICAL CHARACTERISTICS (continued)**

$V_{DD} = 12\text{ V}$ ,  $T_A = T_J = -40^\circ\text{C}$  to  $140^\circ\text{C}$ ,  $1\text{-}\mu\text{F}$  capacitor from  $V_{DD}$  to GND. Currents are positive into, negative out of the specified terminal (unless otherwise noted.)

PARAMETER		TEST CONDITION	MIN	TYP	MAX	UNITS
$t_R$	Rise time <sup>(3)</sup>	$C_{LOAD} = 1.8\text{ nF}$		7	18	ns
$t_F$	Fall time <sup>(3)</sup>	$C_{LOAD} = 1.8\text{ nF}$		6	10	
$t_M$	Delay matching between 2 channels	INA = INB, OUTA and OUTB at 50% transition point		1	4	
$t_{PW}$	Minimum input pulse width that changes the output state			15	25	
$t_{D1}, t_{D2}$	Input to output propagation delay <sup>(3)</sup>	$C_{LOAD} = 1.8\text{ nF}$ , 5-V input pulse	6	13	23	
$t_{D3}, t_{D4}$	EN to output propagation delay <sup>(3)</sup>	$C_{LOAD} = 1.8\text{ nF}$ , 5-V enable pulse	6	13	23	

(3) See timing diagrams in [Figure 1](#), [Figure 2](#), [Figure 3](#) and [Figure 4](#)

**Timing Diagrams**

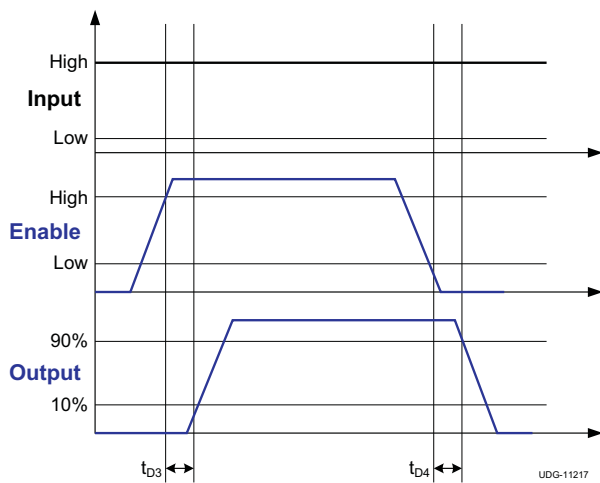

**Figure 1. Enable Function (For Non-Inverting Input Driver Operation)**

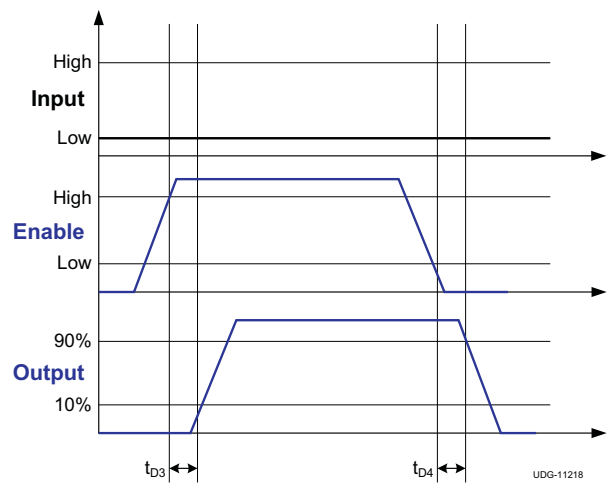

**Figure 2. Enable Function (For Inverting Input Driver Operation)**

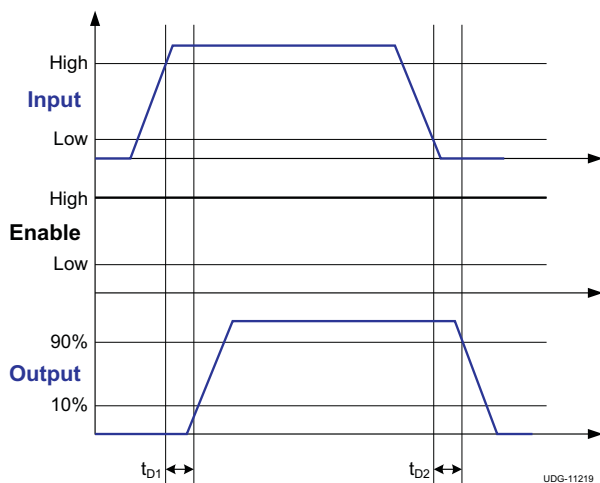

**Figure 3. Non-Inverting Input Driver Operation**

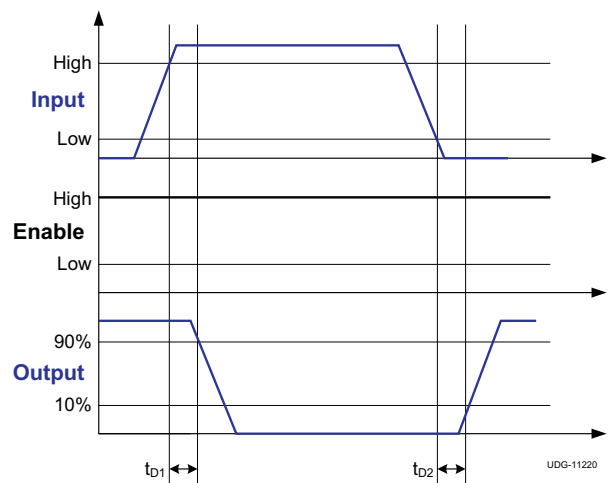

**Figure 4. Inverting Input Driver Operation**

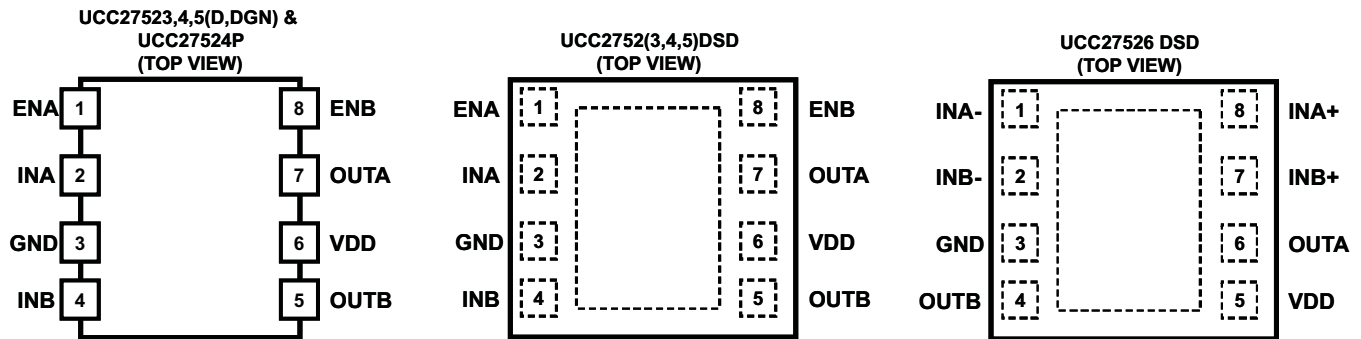
**DEVICE INFORMATION**

**Figure 5.**
**TERMINAL FUNCTIONS (UCC27523 / UCC27524 / UCC27525)**

TERMINAL		I/O	FUNCTION
NUMBER	NAME		
1	ENA	I	<b>Enable input for Channel A:</b> ENA biased LOW Disables Channel A output regardless of INA state, ENA biased HIGH or floating Enables Channel A output, ENA allowed to float hence the pin-to-pin compatibility with UCC2732X N/C pin.
2	INA	I	<b>Input to Channel A:</b> Inverting Input in UCC27523, Non-Inverting Input in UCC27524, Inverting Input in UCC27525, OUTA held LOW if INA is unbiased or floating.
3	GND	-	<b>Ground:</b> All signals referenced to this pin.
4	INB	I	<b>Input to Channel B:</b> Inverting Input in UCC27523, Non-Inverting Input in UCC27524, Non-Inverting Input in UCC27525, OUTB held LOW if INB is unbiased or floating.
5	OUTB	O	<b>Output of Channel B</b>
6	VDD	I	<b>Bias supply input</b>
7	OUTA	O	<b>Output of Channel A</b>
8	ENB	I	<b>Enable input for Channel B:</b> ENB biased LOW Disables Channel B output regardless of INB state, ENB biased HIGH or floating Enables Channel B output, ENB allowed to float hence the pin-to-pin compatibility with UCC2732X N/C pin.

**TERMINAL FUNCTIONS (UCC27526)**

TERMINAL		I/O	FUNCTION
NUMBER	NAME		
1	INA-	I	<b>Inverting Input to Channel A:</b> When Channel A is used in Non-Inverting configuration, connect INA- to GND in order to Enable Channel A output, OUTA held LOW if INA- is unbiased or floating.
2	INB-	I	<b>Inverting Input to Channel B:</b> When Channel B is used in Non-Inverting configuration, connect INB- to GND in order to Enable Channel B output, OUTB held LOW if INB- is unbiased or floating.
3	GND	-	<b>Ground:</b> All signals referenced to this pin.
4	OUTB	I	<b>Output of Channel B</b>
5	VDD	O	<b>Bias Supply Input</b>
6	OUTA	I	<b>Output of Channel A</b>
7	INB+	O	<b>Non-Inverting Input to Channel B:</b> When Channel B is used in Inverting configuration, connect INB+ to VDD in order to Enable Channel B output, OUTB held LOW if INB+ is unbiased or floating.
8	INA+	I	<b>Non-Inverting Input to Channel A:</b> When Channel A is used in Inverting configuration, connect INA+ to VDD in order to Enable Channel A output, OUTA held LOW if INA+ is unbiased or floating.

**Table 1. Device Logic Table (UCC27523/UCC27524/UCC27525)**

ENA	ENB	INA	INB	UCC27523		UCC27524		UCC27525	
				OUTA	OUTB	OUTA	OUTB	OUTA	OUTB
H	H	L	L	H	H	L	L	H	L
H	H	L	H	H	L	L	H	H	H
H	H	H	L	L	H	H	L	L	L
H	H	H	H	L	L	H	H	L	H
L	L	Any	Any	L	L	L	L	L	L
Any	Any	x <sup>(1)</sup>	x <sup>(1)</sup>	L	L	L	L	L	L
x <sup>(1)</sup>	x <sup>(1)</sup>	L	L	H	H	L	L	H	L
x <sup>(1)</sup>	x <sup>(1)</sup>	L	H	H	L	L	H	H	H
x <sup>(1)</sup>	x <sup>(1)</sup>	H	L	L	H	H	L	L	L
x <sup>(1)</sup>	x <sup>(1)</sup>	H	H	L	L	H	H	L	H

(1) Floating condition.

**Table 2. Device Logic Table (UCC27526)**

INx+ (x = A or B)	INx- (x = A or B)	OUTx (x = A or B)
L	L	L
L	H	L
H	L	H
H	H	L
x <sup>(1)</sup>	Any	L
Any	x <sup>(1)</sup>	L

(1) x = Floating condition.

Functional Block Diagrams

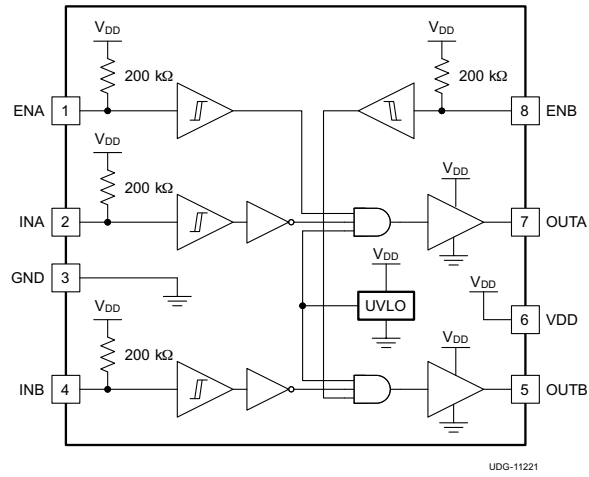

Figure 6. UCC27523 Block Diagram

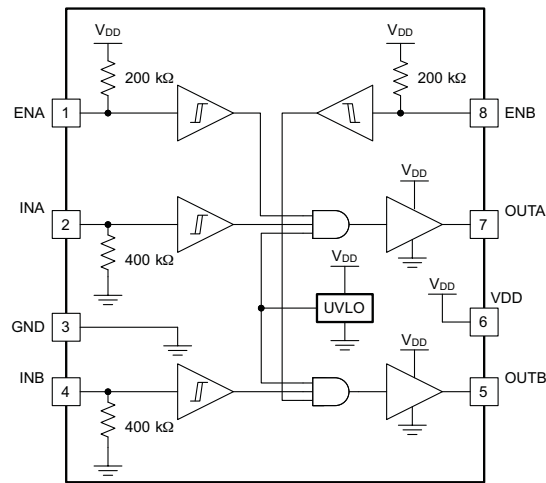

Figure 7. UCC27524 Block Diagram

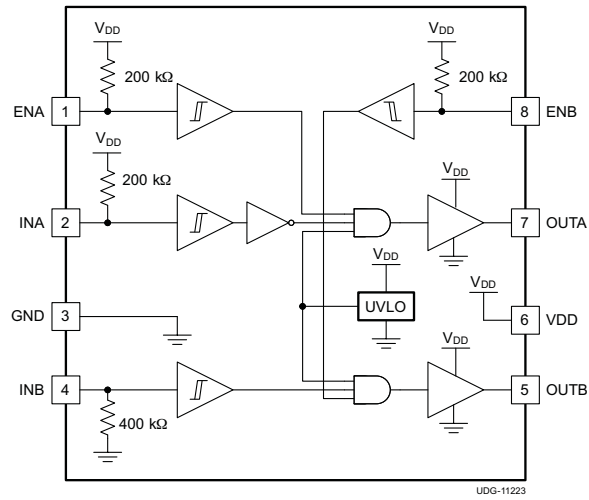

Figure 8. UCC27525 Block Diagram

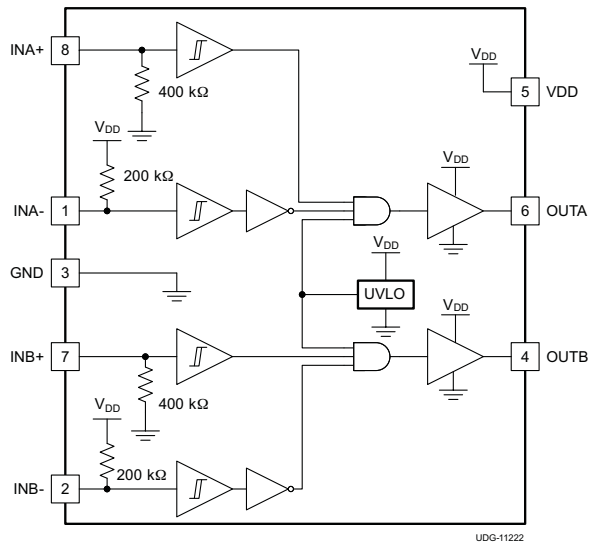

Figure 9. UCC27526 Block Diagram

TYPICAL CHARACTERISTICS

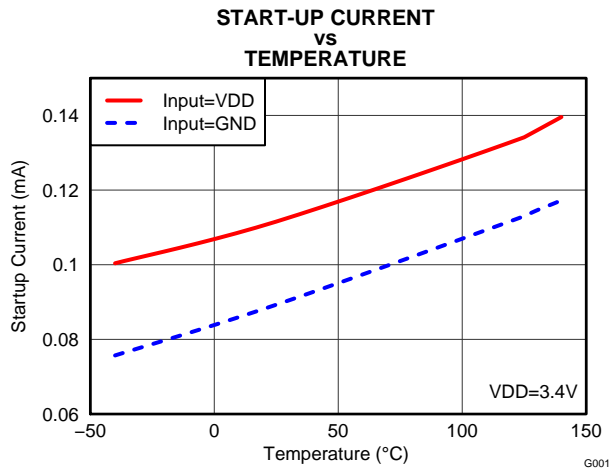

Figure 10.

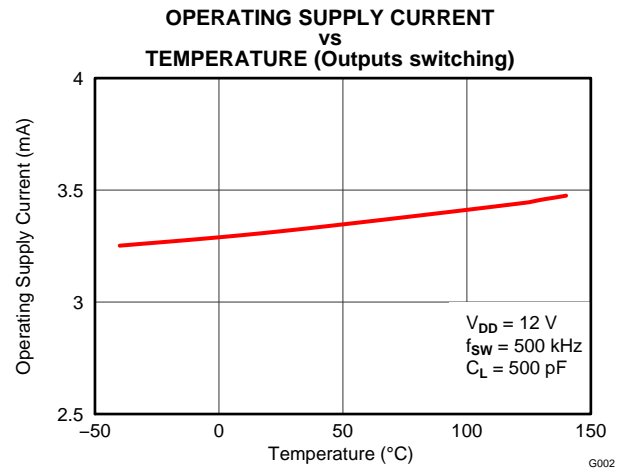

Figure 11.

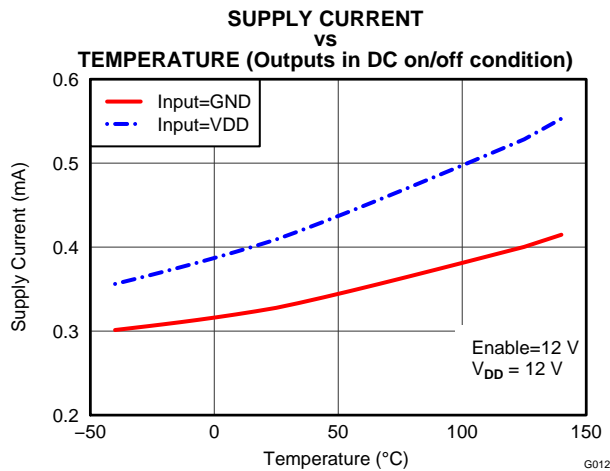

Figure 12.

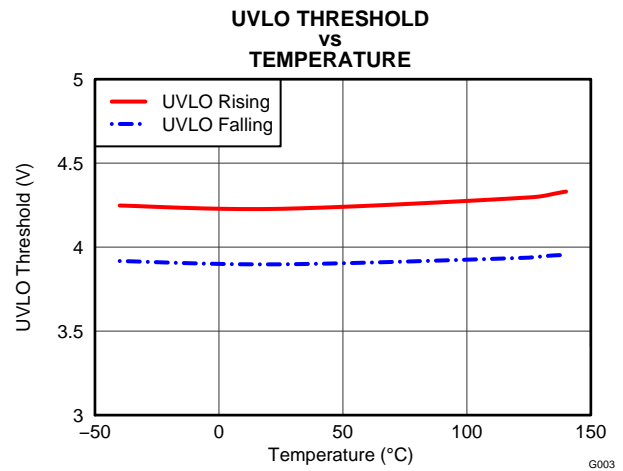

Figure 13.

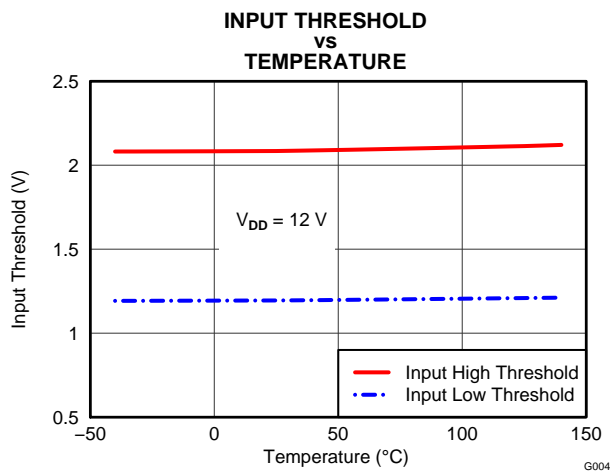

Figure 14.

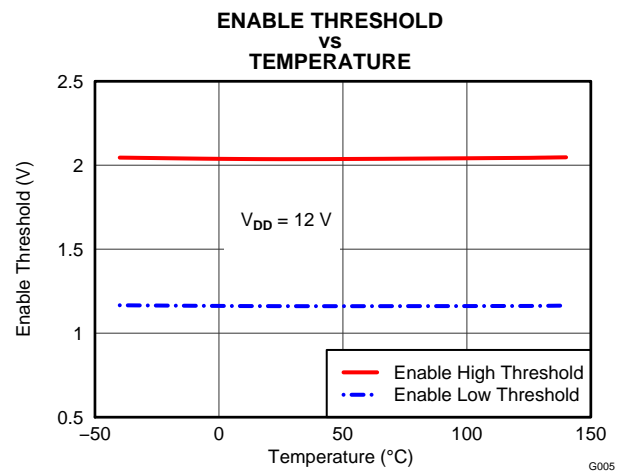
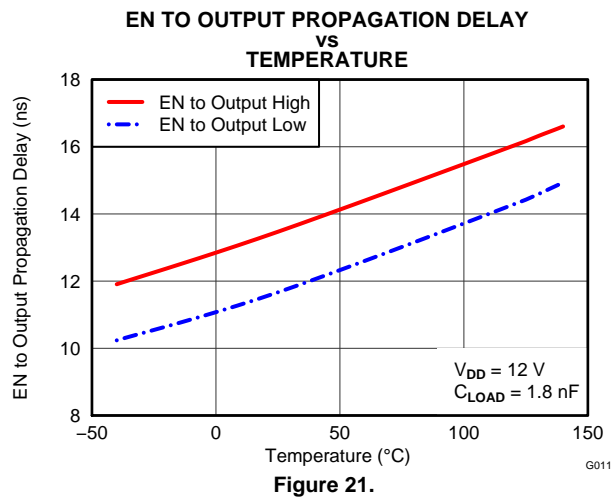
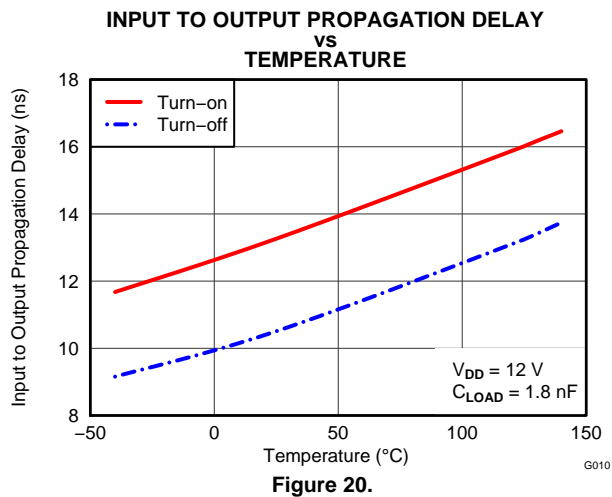
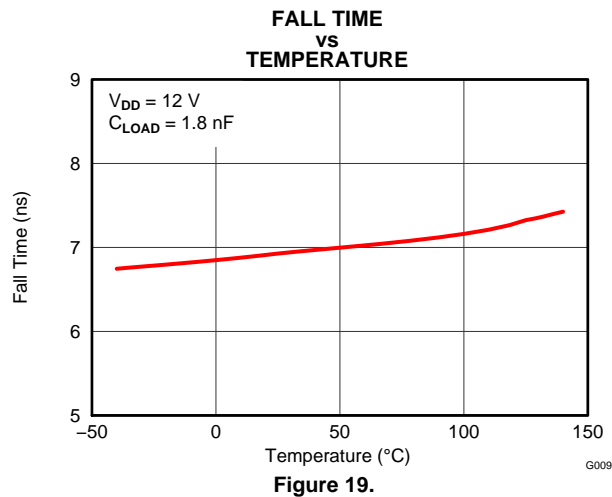
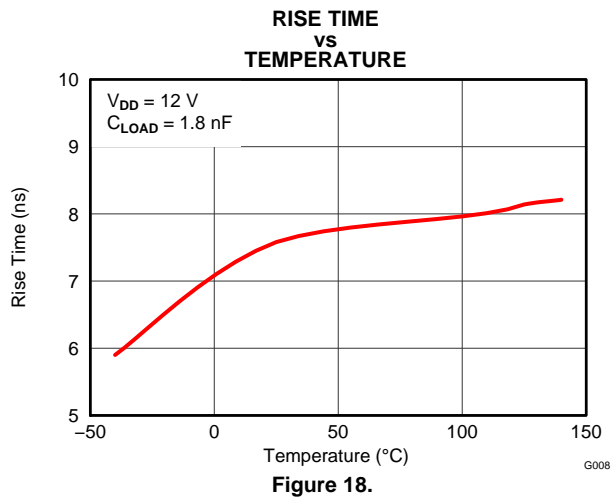
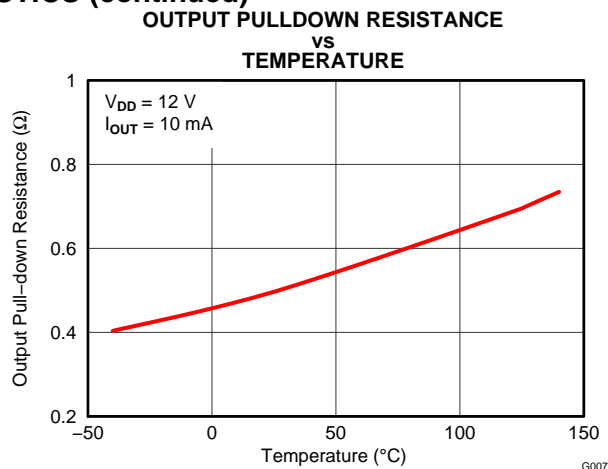
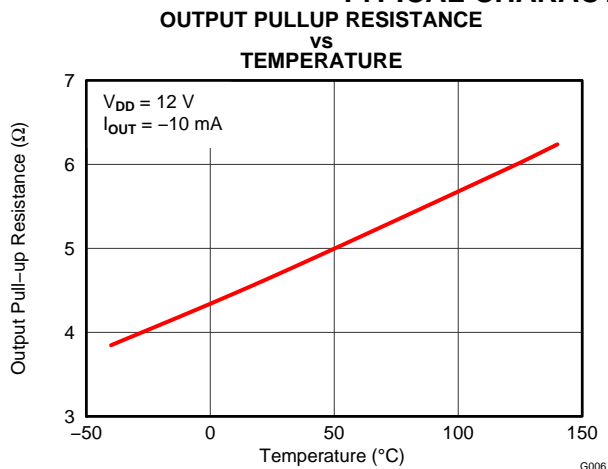

Figure 15.

**TYPICAL CHARACTERISTICS (continued)**



TYPICAL CHARACTERISTICS (continued)

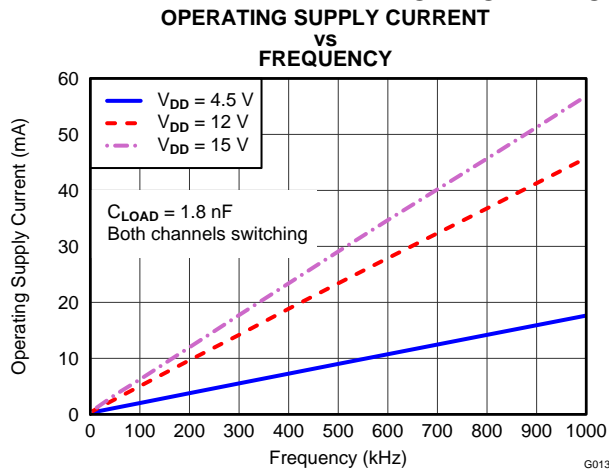

Figure 22.

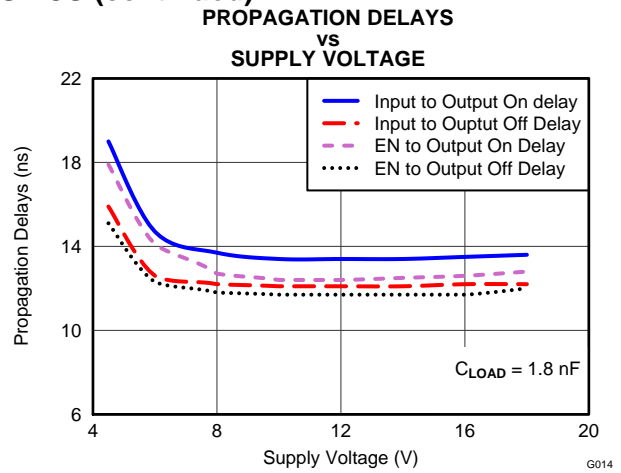

Figure 23.

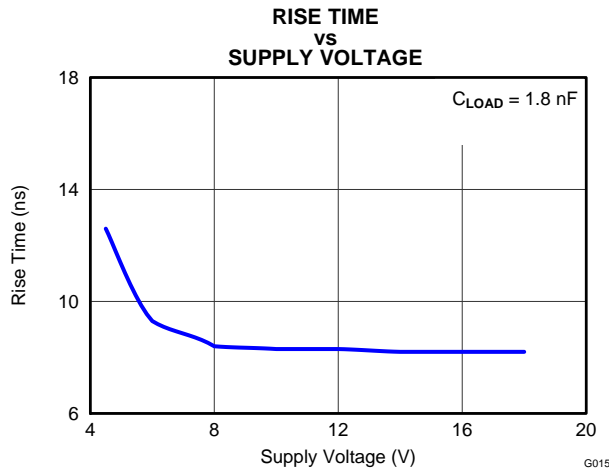

Figure 24.

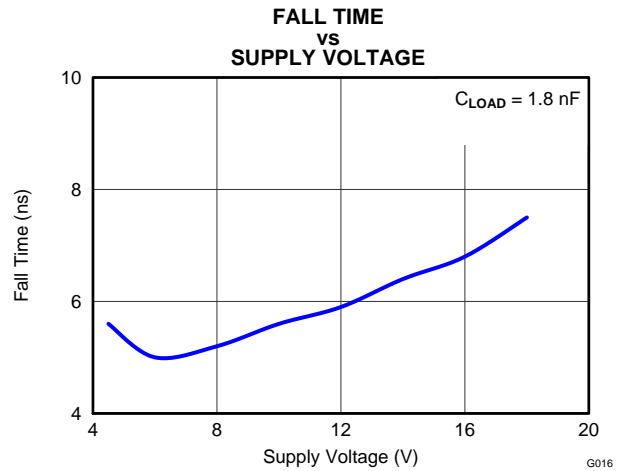

Figure 25.

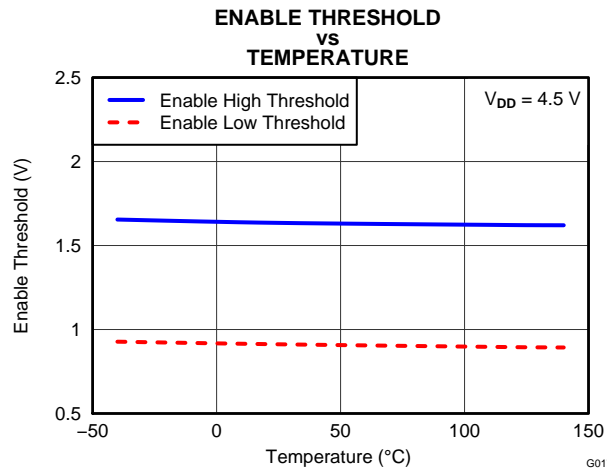

Figure 26.

APPLICATION INFORMATION

High-current gate-driver devices are required in switching power applications for a variety of reasons. In order to effect fast switching of power devices and reduce associated switching-power losses, a powerful gate-driver device employs between the PWM output of control devices and the gates of the power semiconductor devices. Further, gate-driver devices are indispensable when having the PWM controller device directly drive the gates of the switching devices is sometimes not feasible. With advent of digital power, this situation is often encountered because the PWM signal from the digital controller is often a 3.3-V logic signal which is not capable of effectively turning on a power switch. A level-shifting circuitry is needed to boost the 3.3-V signal to the gate-drive voltage (such as 12 V) in order to fully turn on the power device and minimize conduction losses. Traditional buffer-drive circuits based on NPN/PNP bipolar transistors in totem-pole arrangement, being emitter-follower configurations, prove inadequate with digital power because they lack level-shifting capability. Gate-driver devices effectively combine both the level-shifting and buffer-drive functions. Gate-driver devices also find other needs such as minimizing the effect of high-frequency switching noise by locating the high-current driver physically close to the power switch, driving gate-drive transformers and controlling floating power-device gates, reducing power dissipation and thermal stress in controller devices by moving gate-charge power losses into the controller. Finally, emerging wide band-gap power-device technologies such as GaN based switches, which are capable of supporting very high switching frequency operation, are driving special requirements in terms of gate-drive capability. These requirements include operation at low VDD voltages (5 V or lower), low propagation delays, tight delay matching and availability in compact, low-inductance packages with good thermal capability. In summary gate-driver devices are an extremely important component in switching power combining benefits of high-performance, low-cost, component-count, board-space reduction and simplified system design.

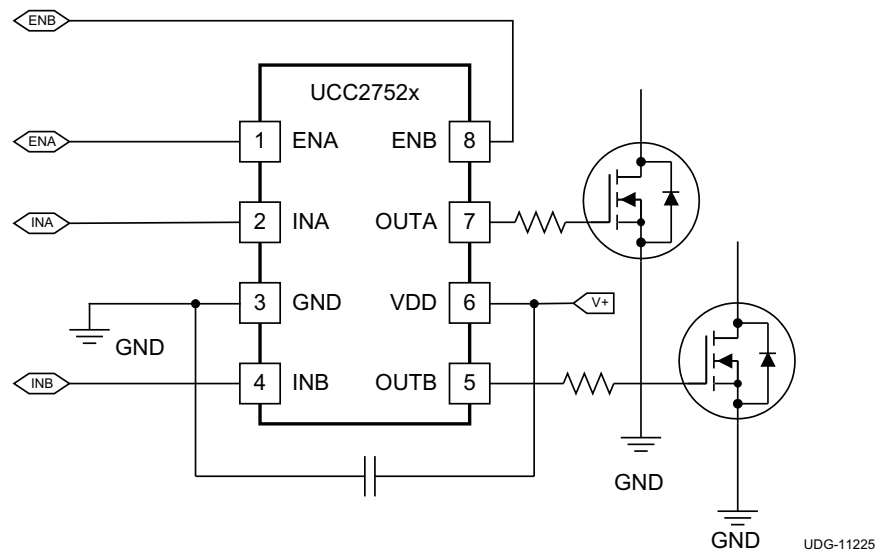
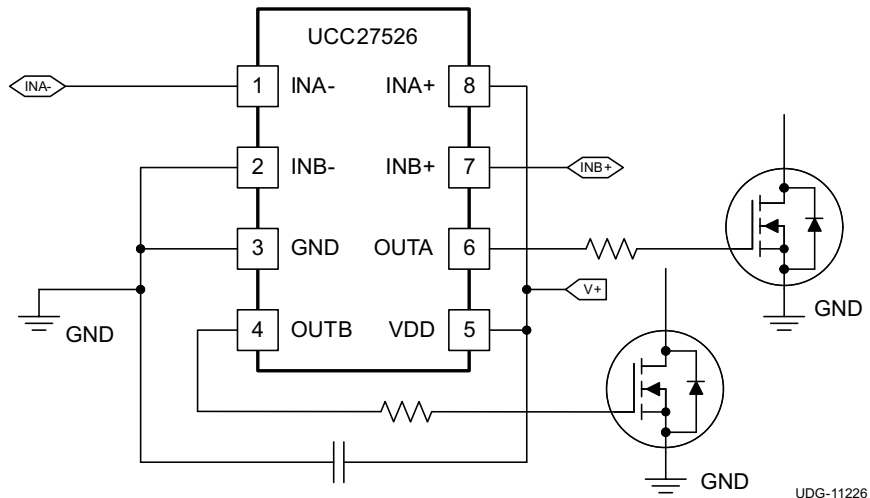
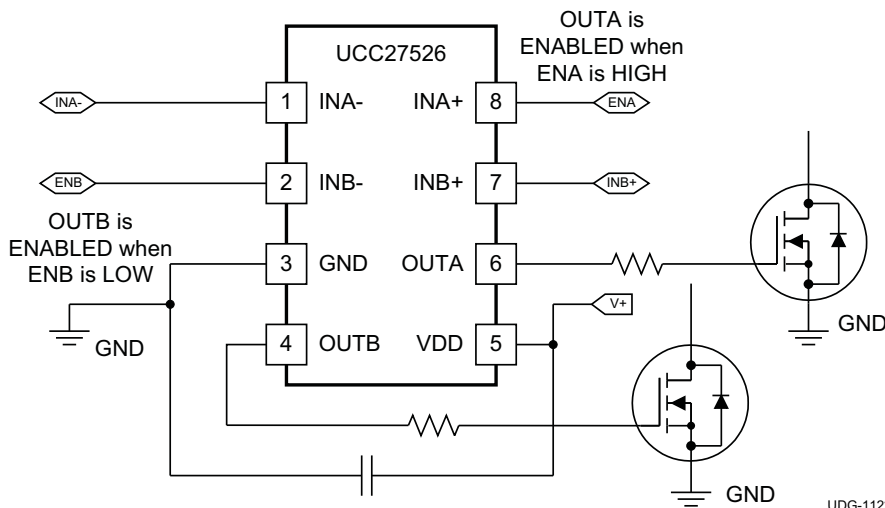

Figure 27. UCC2752x Typical Application Diagram (x = 3, 4 Or 5)



UDG-11226

Figure 28. UCC27526 Channel A in Inverting And Channel B In Non-Inverting Configuration, (Enable Function Not Used)



UDG-11227

Figure 29. UCC27526 Channel A in Inverting And Channel B In Non-Inverting Configuration, (Enable Function Implemented)

**Introduction**

The UCC2752x family of products represent Texas Instruments’ latest generation of dual-channel low-side high-speed gate-driver devices featuring 5-A source/sink current capability, industry best-in-class switching characteristics and a host of other features listed in [Table 3](#) all of which combine to ensure efficient, robust and reliable operation in high-frequency switching power circuits.

**Table 3. UCC2752x Family of Features and Benefits**

FEATURE	BENEFIT
Best-in-class 13-ns (typ) propagation delay	Extremely low-pulse transmission distortion
1-ns (typ) delay matching between channels	Ease of paralleling outputs for higher (2 times) current capability, ease of driving parallel-power switches
Expanded VDD Operating range of 4.5 to 18 V	Flexibility in system design
Expanded operating temperature range of –40°C to +140°C (See <a href="#">ELECTRICAL CHARACTERISTICS</a> table)	
VDD UVLO Protection	Outputs are held Low in UVLO condition, which ensures predictable, glitch-free operation at power-up and power-down
Outputs held Low when input pins (INx) in floating condition	Safety feature, especially useful in passing abnormal condition tests during safety certification
Outputs enable when enable pins (ENx) in floating condition	Pin-to-pin compatibility with UCC2732X family of products from TI, in designs where pin #1, 8 are in floating condition
CMOS/TTL compatible input and enable threshold with wide hysteresis	Enhanced noise immunity, while retaining compatibility with microcontroller logic level input signals (3.3V, 5V) optimized for digital power
Ability of input and enable pins to handle voltage levels not restricted by VDD pin bias voltage	System simplification, especially related to auxiliary bias supply architecture

## VDD and Under Voltage Lockout

The UCC2752x devices have internal undervoltage-lockout (UVLO) protection feature on the VDD pin supply circuit blocks. When VDD is rising and the level is still below UVLO threshold, this circuit holds the output LOW, regardless of the status of the inputs. The UVLO is typically 4.25 V with 350-mV typical hysteresis. This hysteresis prevents chatter when low VDD supply voltages have noise from the power supply and also when there are droops in the VDD bias voltage when the system commences switching and there is a sudden increase in  $I_{DD}$ . The capability to operate at low voltage levels such as below 5 V, along with best in class switching characteristics, is especially suited for driving emerging GaN power semiconductor devices.

For example, at power up, the UCC2752x driver-device output remains LOW until the  $V_{DD}$  voltage reaches the UVLO threshold if Enable pin is active or floating. The magnitude of the OUT signal rises with  $V_{DD}$  until steady-state  $V_{DD}$  is reached. The non-inverting operation in Figure 30 shows that the output remains LOW until the UVLO threshold is reached, and then the output is in-phase with the input. The inverting operation in Figure 31 shows that the output remains LOW until the UVLO threshold is reached, and then the output is out-phase with the input. With UCC27526 the output turns to high-state only if INX+ is high and INX– is low after the UVLO threshold is reached.

Because the device draws current from the VDD pin to bias all internal circuits, for the best high-speed circuit performance, two VDD bypass capacitors are recommended to prevent noise problems. The use of surface mount components is highly recommended. A 0.1- $\mu$ F ceramic capacitor must be located as close as possible to the VDD to GND pins of the gate-driver device. In addition, a larger capacitor (such as 1- $\mu$ F) with relatively low ESR must be connected in parallel and close proximity, in order to help deliver the high-current peaks required by the load. The parallel combination of capacitors presents a low impedance characteristic for the expected current levels and switching frequencies in the application.

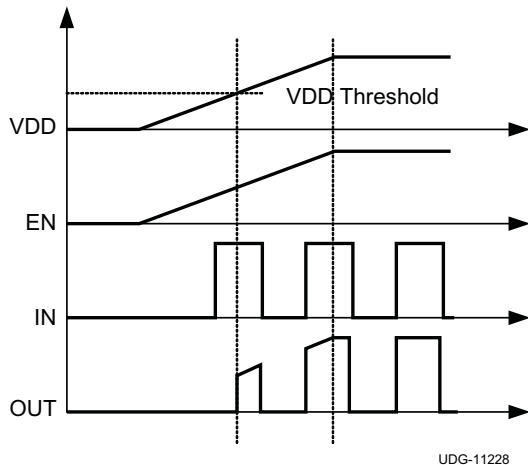

Figure 30. Power-Up Non-Inverting Driver

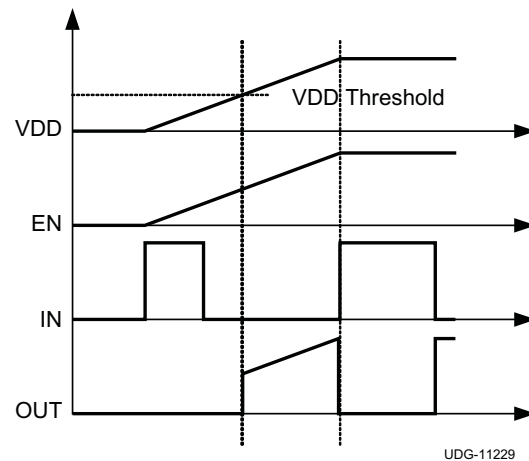

Figure 31. Power-Up Inverting Driver

## Operating Supply Current

The UCC2752x products feature very low quiescent  $I_{DD}$  currents. The typical operating-supply current in UVLO state and fully-on state (under static and switching conditions) are summarized in Figure 10, Figure 11 and Figure 12. The  $I_{DD}$  current when the device is fully on and outputs are in a static state (DC high or DC low, refer Figure 11) represents lowest quiescent  $I_{DD}$  current when all the internal logic circuits of the device are fully operational. The total supply current is the sum of the quiescent  $I_{DD}$  current, the average  $I_{OUT}$  current due to switching and finally any current related to pullup resistors on the enable pins and inverting input pins. For example when the inverting Input pins are pulled low additional current is drawn from VDD supply through the pullup resistors (refer to Figure 6 though Figure 9). Knowing the operating frequency ( $f_{SW}$ ) and the MOSFET gate ( $Q_G$ ) charge at the drive voltage being used, the average  $I_{OUT}$  current can be calculated as product of  $Q_G$  and  $f_{SW}$ .

A complete characterization of the  $I_{DD}$  current as a function of switching frequency at different  $V_{DD}$  bias voltages under 1.8-nF switching load in both channels is provided in Figure 22. The strikingly linear variation and close correlation with theoretical value of average  $I_{OUT}$  indicates negligible shoot-through inside the gate-driver device attesting to its high-speed characteristics.

## Input Stage

The input pins of UCC2752x gate-driver devices are based on a TTL and CMOS compatible input-threshold logic that is independent of the VDD supply voltage. With typically high threshold = 2.1 V and typically low threshold = 1.2 V, the logic level thresholds are conveniently driven with PWM control signals derived from 3.3-V and 5-V digital power-controller devices. Wider hysteresis (typ 0.9 V) offers enhanced noise immunity compared to traditional TTL logic implementations, where the hysteresis is typically less than 0.5 V. UCC2752x devices also feature tight control of the input pin threshold voltage levels which eases system design considerations and ensures stable operation across temperature (refer to [Figure 14](#)). The very low input capacitance on these pins reduces loading and increases switching speed.

The UCC2752x devices feature an important safety feature wherein, whenever any of the input pins is in a floating condition, the output of the respective channel is held in the low state. This is achieved using V<sub>DD</sub> pullup resistors on all the inverting inputs (INA, INB in UCC27523, INA in UCC27525 and INA-, INB- in UCC27526) or GND pulldown resistors on all the non-inverting input pins (INA, INB in UCC27524, INB in UCC27525 and INA+, INB+ in UCC27526), as shown in the device block diagrams.

While UCC27523/4/5 devices feature one input pin per channel, the UCC27526 features a dual input configuration with two input pins available to control the output state of each channel. With the UCC27526 device the user has the flexibility to drive each channel using either a non-inverting input pin (INx+) or an inverting input pin (INx-). The state of the output pin is dependent on the bias on both the INx+ and INx- pins (where x = A, B). Once an input pin is chosen to drive a channel, the other input pin of that channel (the unused input pin) must be properly biased in order to enable the output of the channel. The unused input pin cannot remain in a floating condition because, as mentioned earlier, whenever any input pin is left in a floating condition, the output of that channel is disabled using the internal pullup or pulldown resistors for safety purposes. Alternatively, the unused input pin is used effectively to implement an enable/disable function, as explained below.

- In order to drive the channel x (x = A or B) in a non-inverting configuration, apply the PWM control input signal to INx+ pin. In this case, the unused input pin, INx-, must be biased low (eg. tied to GND) in order to enable the output of this channel.
  - Alternately, the INx- pin can be used to implement the enable/disable function using an external logic signal. OUTx is disabled when INx- is biased High and OUTx is enabled when INx- is biased low.
- In order to drive the channel x (x = A or B) in an Inverting configuration, apply the PWM control input signal to INx- pin. In this case, the unused input pin, INx+, must be biased high (eg. tied to VDD) in order to enable the output of the channel.
  - Alternately, the INx+ pin can be used to implement the enable/disable function using an external logic signal. OUTx is disabled when INx+ is biased low and OUTx is enabled when INx+ is biased high.
- Finally, it is worth noting that the UCC27526 output pin can be driven into high state only when INx+ pin is biased high and INx- input is biased low.

Refer to the input/output logic truth table and typical application diagram, ([Figure 28](#) and [Figure 29](#)), for additional clarification.

The input stage of each driver is driven by a signal with a short rise or fall time. This condition is satisfied in typical power supply applications, where the input signals are provided by a PWM controller or logic gates with fast transition times (<200 ns) with a slow changing input voltage, the output of the driver may switch repeatedly at a high frequency. While the wide hysteresis offered in UCC2752x definitely alleviates this concern over most other TTL input threshold devices, extra care is necessary in these implementations. If limiting the rise or fall times to the power device is the primary goal, then an external resistance is highly recommended between the output of the driver and the power device. This external resistor has the additional benefit of reducing part of the gate-charge related power dissipation in the gate driver device package and transferring it into the external resistor itself.

## Enable Function

The enable function is an extremely beneficial feature in gate-driver devices especially for certain applications such as synchronous rectification where the driver outputs disable in light-load conditions to prevent negative current circulation and to improve light-load efficiency.

UCC27523/4/5 devices are provided with independent enable pins ENx for exclusive control of each driver-channel operation. The enable pins are based on a non-inverting configuration (active-high operation). Thus when ENx pins are driven high the drivers are enabled and when ENx pins are driven low the drivers are disabled. Like the input pins, the enable pins are also based on a TTL and CMOS compatible input-threshold logic that is independent of the supply voltage and are effectively controlled using logic signals from 3.3-V and 5-V microcontrollers. The UCC2752X devices also feature tight control of the Enable-function threshold-voltage levels which eases system design considerations and ensures stable operation across temperature (refer to [Figure 15](#)). The ENx pins are internally pulled up to VDD using pullup resistors as a result of which the outputs of the device are enabled in the default state. Hence the ENx pins are left floating or Not Connected (N/C) for standard operation, where the enable feature is not needed. Essentially, this floating allows the UCC27523/4/5 devices to be pin-to-pin compatible with TI's previous generation drivers UCC27323/4/5 respectively, where pins #1, 8 are N/C pins. If the channel A and Channel B inputs and outputs are connected in parallel to increase the driver current capacity, ENA and ENB are connected and driven together.

The UCC27526 device does not feature dedicated enable pins. However, as mentioned earlier, an enable/disable function is easily implemented in UCC27526 using the unused input pin. When INx+ is pulled-down to GND or INx- is pulled-down to VDD, the output is disabled. Thus INx+ pin is used like an enable pin that is based on active high logic, while INx- is used like an enable pin that is based on active low logic. Note that while the ENA, ENB pins in UCC27523/4/5 are allowed to be in floating condition during standard operation and the outputs will be enabled, the INx+, INx- pins in UCC27526 are not allowed to be floating because this will disable the outputs.

## Output Stage

The UCC2752x device output stage features a unique architecture on the pullup structure which delivers the highest peak-source current when it is most needed during the Miller plateau region of the power-switch turnon transition (when the power switch drain or collector voltage experiences  $dV/dt$ ). The output stage pullup structure features a P-Channel MOSFET and an additional N-Channel MOSFET in parallel. The function of the N-Channel MOSFET is to provide a brief boost in the peak sourcing current enabling fast turnon. This is accomplished by briefly turning-on the N-Channel MOSFET during a narrow instant when the output is changing state from Low to High.

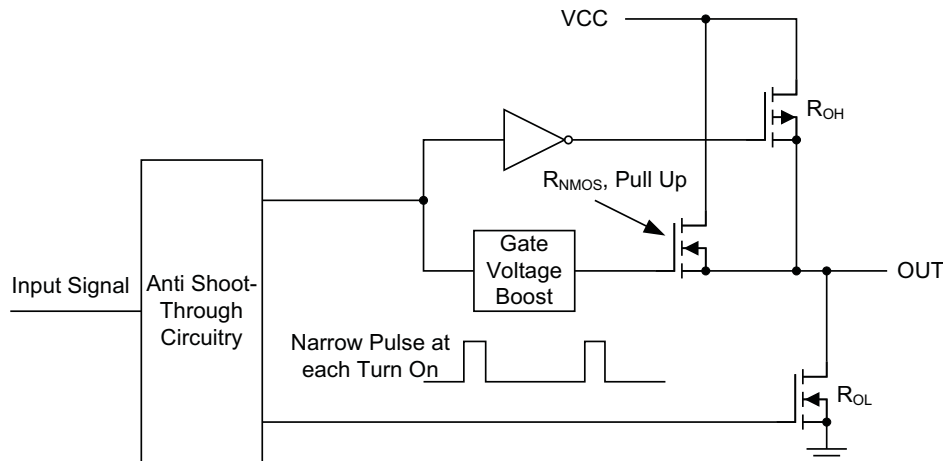

**Figure 32. UCC2752X Gate Driver Output Structure**

The  $R_{OH}$  parameter (see [ELECTRICAL CHARACTERISTICS](#)) is a DC measurement and it is representative of the on-resistance of the P-Channel device only. This is because the N-Channel device is held in the off state in DC condition and is turned-on only for a narrow instant when output changes state from low to high. Note that effective resistance of UCC2752x pullup stage during the turnon instant is much lower than what is represented by  $R_{OH}$  parameter.

The pulldown structure in UCC2752x is simply composed of a N-Channel MOSFET. The  $R_{OL}$  parameter (see [ELECTRICAL CHARACTERISTICS](#)), which is also a DC measurement, is representative of the impedance of the pulldown stage in the device. In UCC2752x, the effective resistance of the hybrid pullup structure during turnon is estimated to be approximately  $1.5 \times R_{OL}$ , estimated based on design considerations.

Each output stage in UCC2752x is capable of supplying 5-A peak source and 5-A peak sink current pulses. The output voltage swings between VDD and GND providing rail-to-rail operation, thanks to the MOS-output stage which delivers very low drop-out. The presence of the MOSFET-body diodes also offers low impedance to switching overshoots and undershoots which means that in many cases, external Schottky-diode clamps may be eliminated. The outputs of these drivers are designed to withstand 500-mA reverse current without either damage to the device or logic malfunction.

The UCC2752x devices are particularly suited for dual-polarity, symmetrical drive-gate transformer applications where the primary winding of transformer driven by OUTA and OUTB, with inputs INA and INB being driven complementary to each other. This situation is due to the extremely low drop-out offered by the MOS output stage of these devices, both during high ( $V_{OH}$ ) and low ( $V_{OL}$ ) states along with the low impedance of the driver output stage, all of which allow alleviate concerns regarding transformer demagnetization and flux imbalance. The low propagation delays also ensure accurate reset for high-frequency applications.

For applications that have zero voltage switching during power MOSFET turnon or turnoff interval, the driver supplies high-peak current for fast switching even though the miller plateau is not present. This situation often occurs in synchronous rectifier applications because the body diode is generally conducting before power MOSFET is switched on.

## Low Propagation Delays and Tightly Matched Outputs

The UCC2752x driver devices feature a best in class, 13-ns (typical) propagation delay between input and output which goes to offer the lowest level of pulse-transmission distortion available in the industry for high frequency switching applications. For example in synchronous rectifier applications, the SR MOSFETs are driven with very low distortion when a single driver device is used to drive both the SR MOSFETs. Further, the driver devices also feature an extremely accurate, 1-ns (typ) matched internal-propagation delays between the two channels which is beneficial for applications requiring dual gate drives with critical timing. For example in a PFC application, a pair of paralleled MOSFETs may be driven independently using each output channel, which the inputs of both channels are driven by a common control signal from the PFC controller device. In this case the 1ns delay matching ensures that the paralleled MOSFETs are driven in a simultaneous fashion with the minimum of turnon delay difference. Yet another benefit of the tight matching between the two channels is that the two channels are connected together to effectively increase current drive capability, for example A and B channels may be combined into a single driver by connecting the INA and INB inputs together and the OUTA and OUTB outputs together. Then, a single signal controls the paralleled combination.

Caution must be exercised when directly connecting OUTA and OUTB pins together because there is the possibility that any delay between the two channels during turnon or turnoff may result in shoot-through current conduction as shown in Figure 33. While the two channels are inherently very well matched (4-ns Max propagation delay), note that there may be differences in the input threshold voltage level between the two channels which causes the delay between the two outputs especially when slow dV/dt input signals are employed. The following guidelines are recommended whenever the two driver channels are paralleled using direct connections between OUTA and OUTB along with INA and INB:

- Use very fast dV/dt input signals (20 V/ $\mu$ s or greater) on INA and INB pins to minimize impact of differences in input thresholds causing delays between the channels.
- INA and INB connections must be made as close to the device pins as possible.

Wherever possible, a safe practice would be to add an option in the design to have gate resistors in series with OUTA and OUTB. This allows the option to use 0- $\Omega$  resistors for paralleling outputs directly or to add appropriate series resistances to limit shoot-through current, should it become necessary.

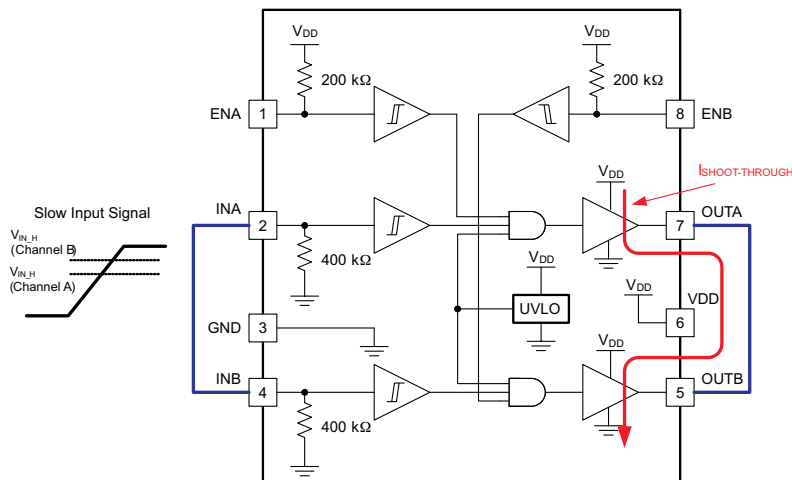

**Figure 33. Slow Input Signal May Cause Shoot-Through Between Channels During Paralleling (Recommended dV/dt Is 20 V/ $\mu$ s Or Higher)**

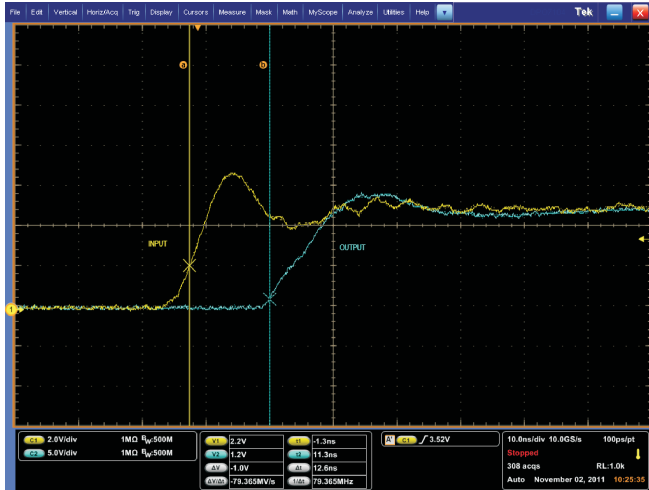

Figure 34. Turnon Propagation Delay ( $C_L = 1.8 \text{ nF}$ ,  $V_{DD} = 12 \text{ V}$ )

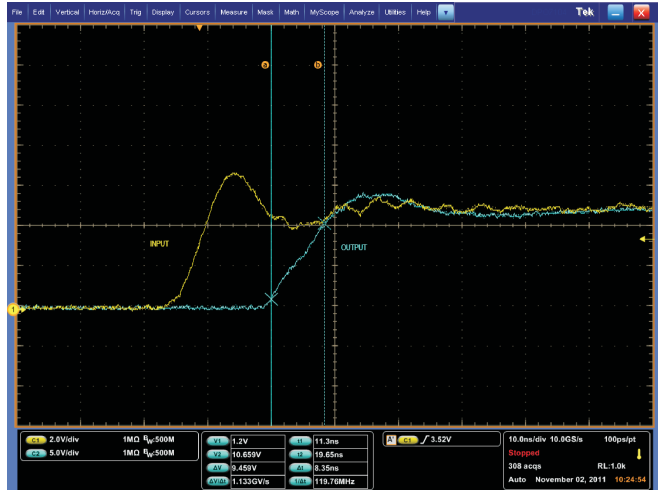

Figure 35. Turnon Rise Time ( $C_L = 1.8 \text{ nF}$ ,  $V_{DD} = 12 \text{ V}$ )

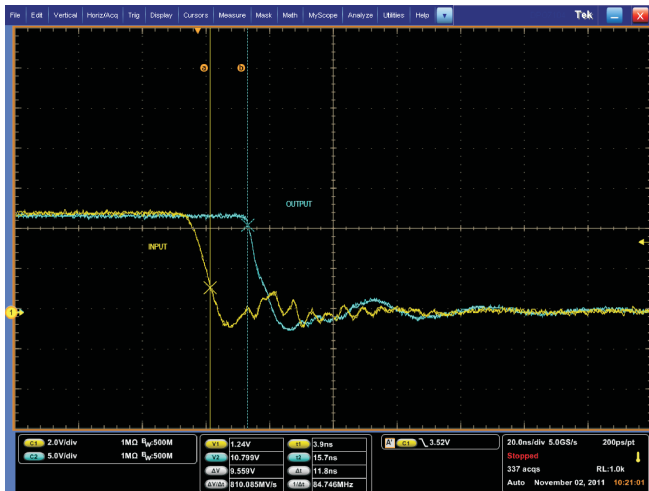

Figure 36. TurnOff Propagation Delay ( $C_L = 1.8 \text{ nF}$ ,  $V_{DD} = 12 \text{ V}$ )

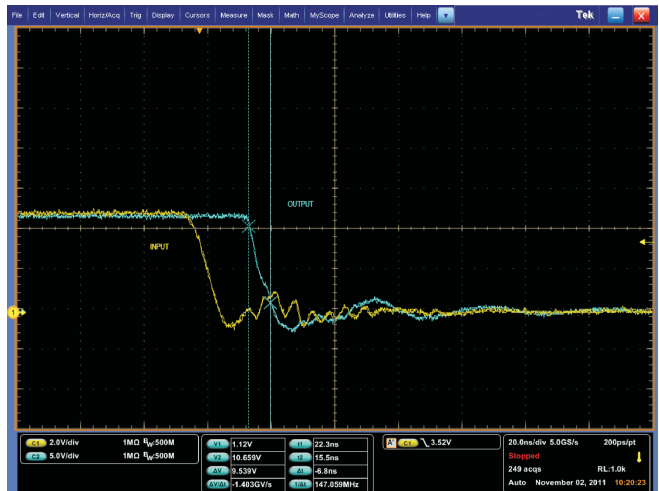

Figure 37. TurnOff Fall Time ( $C_L = 1.8 \text{ nF}$ ,  $V_{DD} = 12 \text{ V}$ )

## Drive Current and Power Dissipation

The UCC27523/4/5/6 family of drivers are capable of delivering 5-A of current to a MOSFET gate for a period of several-hundred nanoseconds at  $V_{DD} = 12\text{ V}$ . High peak current is required to turn the device ON quickly. Then, to turn the device OFF, the driver is required to sink a similar amount of current to ground which repeats at the operating frequency of the power device. The power dissipated in the gate driver device package depends on the following factors:

- Gate charge required of the power MOSFET (usually a function of the drive voltage  $V_{GS}$ , which is very close to input bias supply voltage  $V_{DD}$  due to low  $V_{OH}$  drop-out)
- Switching frequency
- Use of external gate resistors

Because UCC2752x features very low quiescent currents and internal logic to eliminate any shoot-through in the output driver stage, their effect on the power dissipation within the gate driver can be safely assumed to be negligible.

When a driver device is tested with a discrete, capacitive load calculating the power that is required from the bias supply is fairly simple. The energy that must be transferred from the bias supply to charge the capacitor is given by [Equation 1](#).

$$E_G = \frac{1}{2} C_{LOAD} V_{DD}^2 \quad (1)$$

where is load capacitor and is bias voltage feeding the driver.

There is an equal amount of energy dissipated when the capacitor is charged. This leads to a total power loss given by [Equation 2](#).

$$P_G = C_{LOAD} V_{DD}^2 f_{SW} \quad (2)$$

where

- $f_{SW}$  is the switching frequency

With  $V_{DD} = 12\text{ V}$ ,  $C_{LOAD} = 10\text{ nF}$  and  $f_{SW} = 300\text{ kHz}$  the power loss is calculated as (see [Equation 3](#)):

$$P_G = 10\text{ nF} \times 12\text{ V}^2 \times 300\text{ kHz} = 0.432\text{ W} \quad (3)$$

The switching load presented by a power MOSFET is converted to an equivalent capacitance by examining the gate charge required to switch the device. This gate charge includes the effects of the input capacitance plus the added charge needed to swing the drain voltage of the power device as it switches between the ON and OFF states. Most manufacturers provide specifications that provide the typical and maximum gate charge, in nC, to switch the device under specified conditions. Using the gate charge  $Q_g$ , the power that must be dissipated when charging a capacitor is determined which by using the equivalence  $Q_g = C_{LOAD}V_{DD}$  to provide Equation 4 for power:

$$P_G = C_{LOAD}V_{DD}^2f_{SW} = Q_gV_{DD}f_{SW} \quad (4)$$

Assuming that UCC2752x is driving power MOSFET with 60 nC of gate charge ( $Q_g = 60$  nC at  $V_{DD} = 12$  V) on each output, the gate charge related power loss is calculated as (see Equation 5):

$$P_G = 2 \times 60 \text{ nC} \times 12 \text{ V} \times 300 \text{ kHz} = 0.432 \text{ W} \quad (5)$$

This power  $P_G$  is dissipated in the resistive elements of the circuit when the MOSFET turns on or turns off. Half of the total power is dissipated when the load capacitor is charged during turnon, and the other half is dissipated when the load capacitor is discharged during turnoff. When no external gate resistor is employed between the driver and MOSFET/IGBT, this power is completely dissipated inside the driver package. With the use of external gate drive resistors, the power dissipation is shared between the internal resistance of driver and external gate resistor in accordance to the ratio of the resistances (more power dissipated in the higher resistance component). Based on this simplified analysis, the driver power dissipation during switching is calculated as follows (see Equation 6):

$$P_{SW} = 0.5 \times Q_G \times V_{DD} \times f_{SW} \times \left( \frac{R_{OFF}}{R_{OFF} + R_{GATE}} + \frac{R_{ON}}{R_{ON} + R_{GATE}} \right)$$

where

- $R_{OFF} = R_{OL}$
- $R_{ON}$  (effective resistance of pullup structure) =  $1.5 \times R_{OL}$  (6)

In addition to the above gate-charge related power dissipation, additional dissipation in the driver is related to the power associated with the quiescent bias current consumed by the device to bias all internal circuits such as input stage (with pullup and pulldown resistors), enable, and UVLO sections. As shown in Figure 11, the quiescent current is less than 0.6 mA even in the highest case. The quiescent power dissipation is calculated easily with Equation 7.

$$P_Q = I_{DD}V_{DD} \quad (7)$$

Assuming ,  $I_{DD} = 6$  mA, the power loss is:

$$P_Q = 0.6 \text{ mA} \times 12 \text{ V} = 7.2 \text{ mW} \quad (8)$$

Clearly, this power loss is insignificant compared to gate charge related power dissipation calculated earlier.

With a 12-V supply, the bias current is estimated as follows, with an additional 0.6-mA overhead for the quiescent consumption:

$$I_{DD} \sim \frac{P_G}{V_{DD}} = \frac{0.432 \text{ W}}{12 \text{ V}} = 0.036 \text{ A} \quad (9)$$

## Thermal Information

The useful range of a driver is greatly affected by the drive power requirements of the load and the thermal characteristics of the device package. In order for a gate driver device to be useful over a particular temperature range the package must allow for the efficient removal of the heat produced while keeping the junction temperature within rated limits. The UCC27523/4/5/6 family of drivers is available in four different packages to cover a range of application requirements. The thermal metrics for each of these packages are summarized in the Thermal Information section of the datasheet. For detailed information regarding the thermal information table, please refer to Application Note from Texas Instruments entitled, *IC Package Thermal Metrics* ([SPRA953](#)).

Among the different package options available in the UCC2752x family, of particular mention are the DSD & DGN packages when it comes to power dissipation capability. The MSOP PowerPAD-8 (DGN) package and 3-mm x 3-mm WSON (DSD) package offer a means of removing the heat from the semiconductor junction through the bottom of the package. Both these packages offer an exposed thermal pad at the base of the package. This pad is soldered to the copper on the printed circuit board directly underneath the device package, reducing the thermal resistance to a very low value. This allows a significant improvement in heat-sinking over that available in the D or P packages. The printed circuit board must be designed with thermal lands and thermal vias to complete the heat removal subsystem. Note that the exposed pads in the MSOP-8 (PowerPAD) and WSON-8 packages are not directly connected to any leads of the package, however, it is electrically and thermally connected to the substrate of the device which is the ground of the device. TI recommends to externally connect the exposed pads to GND in PCB layout for better EMI immunity.

## PCB Layout

Proper PCB layout is extremely important in a high-current fast-switching circuit to provide appropriate device operation and design robustness. The UCC27523/4/5/6 family of gate drivers incorporates short propagation delays and powerful output stages capable of delivering large current peaks with very fast rise and fall times at the gate of power MOSFET to facilitate voltage transitions very quickly. At higher VDD voltages, the peak current capability is even higher (5-A peak current is at VDD = 12 V). Very high di/dt causes unacceptable ringing if the trace lengths and impedances are not well controlled. The following circuit layout guidelines are strongly recommended when designing with these high-speed drivers.

- Locate the driver device as close as possible to power device in order to minimize the length of high-current traces between the Output pins and the Gate of the power device.
- Locate the VDD bypass capacitors between VDD and GND as close as possible to the driver with minimal trace length to improve the noise filtering. These capacitors support high peak current being drawn from VDD during turnon of power MOSFET. The use of low inductance SMD components such as chip resistors and chip capacitors is highly recommended.
- The turnon and turnoff current loop paths (driver device, power MOSFET and VDD bypass capacitor) should be minimized as much as possible in order to keep the stray inductance to a minimum. High di/dt is established in these loops at 2 instances during turnon and turnoff transients, which will induce significant voltage transients on the output pin of the driver device and Gate of the power MOSFET.
- Wherever possible, parallel the source and return traces, taking advantage of flux cancellation
- Separate power traces and signal traces, such as output and input signals.
- Star-point grounding is a good way to minimize noise coupling from one current loop to another. The GND of the driver is connected to the other circuit nodes such as source of power MOSFET and ground of PWM controller at one, single point. The connected paths must be as short as possible to reduce inductance and be as wide as possible to reduce resistance.
- Use a ground plane to provide noise shielding. Fast rise and fall times at OUT may corrupt the input signals during transition. The ground plane must not be a conduction path for any current loop. Instead the ground plane must be connected to the star-point with one single trace to establish the ground potential. In addition to noise shielding, the ground plane can help in power dissipation as well
- In noisy environments, tying inputs of an unused channel of UCC27526 to VDD (in case of INx+) or GND (in case of INx-) using short traces in order to ensure that the output is enabled and to prevent noise from causing malfunction in the output may be necessary.
- Exercise caution when replacing the UCC2732x/UCC2742x devices with the UCC2752x:
  - UCC2752x is a much stronger gate driver (5-A peak current versus 4-A peak current).
  - UCC2752x is a much faster gate driver (13-ns/13-ns rise/fall propagation delay versus 25-ns/35-ns rise/fall propagation delay).

**REVISION HISTORY**
**Changes from Original (November 2011) to Revision A Page**

- Changed 数据表装态到生产数据。 ..... 1

**Changes from Revision A (November 2011) to Revision B Page**

- Added note to packaging section, "DSD package is rated MSL level 2". ..... 2
- Changed Supply start threshold row to include two temperature ranges. .... 5
- Changed Minimum operating voltage after supply start min and max values from 3.6 V to 4.2 V to 3.40 V and 4.40 V. .... 5
- Changed Supply voltage hysteresis typ value from 0.35 to 0.30. .... 5
- Changed UCC27526 Block Diagram drawing. .... 10
- Changed UCC27526 Channel A in Inverting and Channel B in Non-Inverting Configuration drawing. .... 15

**Changes from Revision B ( December 2011) to Revision C Page**

- Added  $R_{OH}$  note in the Outputs (OUTA, OUTB) section. .... 5
- Added an updated Output Stage section. .... 20
- Added UCC2752X Gate Driver Output Structure image ..... 20
- Added an updated Low Propagation Delays and Tightly Matched Outputs section. .... 21
- Added Slow Input Signal Combined with Differences in Input Threshold Voltage image. .... 21
- Added updated Drive Current and Power Dissipation section. .... 23
- Added a PSW... equation. .... 24

**Changes from Revision C (March 2012) to Revision D Page**

- Changed Inputs (INA, INB, INA+, INA-, INB+, INB-) section to include UCC2752X (D, DGN, DSD) information. .... 5
- Added Inputs (INA, INB, INA+, INA-, INB+, INB-) UCC27524P ONLY section. .... 5
- Changed Enable (ENA, ENB) section to include UCC2752X (D, DGN, DSD) information. .... 5
- Added ENABLE (ENA, ENB) UCC27524P ONLY section. .... 5

**Changes from Revision D (April 2012) to Revision E Page**

- Added OUTA, OUTB voltage field and values. .... 3
- Changed table note from "Values are verified by characterization and are not production tested." to "Values are verified by characterization on bench." ..... 3
- Added note, "Values are verified by characterization and are not production tested." ..... 3
- Changed Switching Time  $t_{PW}$  values from 10 ns and 25 ns to 15 ns and 25 ns ns. .... 5
- Changed Functional Block Diagrams images. .... 9
- Changed Slow Input Signal Figure 33. .... 21

**Changes from Revision E (June 2012) to Revision F Page**

- Added 0.5 to  $P_{SW}$  equation in *Drive Current and Power Dissipation* section ..... 24

**PACKAGING INFORMATION**

Orderable Device	Status (1)	Package Type	Package Drawing	Pins	Package Qty	Eco Plan (2)	Lead finish/ Ball material (6)	MSL Peak Temp (3)	Op Temp (°C)	Device Marking (4/5)	Samples
UCC27523D	ACTIVE	SOIC	D	8	75	RoHS & Green	NIPDAU	Level-1-260C-UNLIM	-40 to 140	27523	<a href="#">Samples</a>
UCC27523DGN	ACTIVE	HVSSOP	DGN	8	80	RoHS & Green	NIPDAUAG	Level-1-260C-UNLIM	-40 to 140	27523	<a href="#">Samples</a>
UCC27523DGNR	ACTIVE	HVSSOP	DGN	8	2500	RoHS & Green	NIPDAUAG	Level-1-260C-UNLIM	-40 to 140	27523	<a href="#">Samples</a>
UCC27523DR	ACTIVE	SOIC	D	8	2500	RoHS & Green	NIPDAU	Level-1-260C-UNLIM	-40 to 140	27523	<a href="#">Samples</a>
UCC27523DSDR	ACTIVE	SON	DSD	8	3000	RoHS & Green	NIPDAU	Level-2-260C-1 YEAR	-40 to 140	27523	<a href="#">Samples</a>
UCC27523DSDT	ACTIVE	SON	DSD	8	250	RoHS & Green	NIPDAU	Level-2-260C-1 YEAR	-40 to 140	27523	<a href="#">Samples</a>
UCC27524D	ACTIVE	SOIC	D	8	75	RoHS & Green	NIPDAU	Level-1-260C-UNLIM	-40 to 140	27524	<a href="#">Samples</a>
UCC27524DGN	ACTIVE	HVSSOP	DGN	8	80	RoHS & Green	NIPDAUAG	Level-1-260C-UNLIM	-40 to 140	27524	<a href="#">Samples</a>
UCC27524DGNR	ACTIVE	HVSSOP	DGN	8	2500	RoHS & Green	NIPDAUAG	Level-1-260C-UNLIM	-40 to 140	27524	<a href="#">Samples</a>
UCC27524DR	ACTIVE	SOIC	D	8	2500	RoHS & Green	NIPDAU	Level-1-260C-UNLIM	-40 to 140	27524	<a href="#">Samples</a>
UCC27524DSDR	ACTIVE	SON	DSD	8	3000	RoHS & Green	NIPDAU	Level-2-260C-1 YEAR	-40 to 140	SBA	<a href="#">Samples</a>
UCC27524DSDT	ACTIVE	SON	DSD	8	250	RoHS & Green	NIPDAU	Level-2-260C-1 YEAR	-40 to 140	SBA	<a href="#">Samples</a>
UCC27524P	ACTIVE	PDIP	P	8	50	RoHS & Green	NIPDAU	N / A for Pkg Type	-40 to 140	27524	<a href="#">Samples</a>
UCC27525D	ACTIVE	SOIC	D	8	75	RoHS & Green	NIPDAU	Level-1-260C-UNLIM	-40 to 140	27525	<a href="#">Samples</a>
UCC27525DGN	ACTIVE	HVSSOP	DGN	8	80	RoHS & Green	NIPDAUAG	Level-1-260C-UNLIM	-40 to 140	27525	<a href="#">Samples</a>
UCC27525DGNR	ACTIVE	HVSSOP	DGN	8	2500	RoHS & Green	NIPDAUAG	Level-1-260C-UNLIM	-40 to 140	27525	<a href="#">Samples</a>
UCC27525DR	ACTIVE	SOIC	D	8	2500	RoHS & Green	NIPDAU	Level-1-260C-UNLIM	-40 to 140	27525	<a href="#">Samples</a>
UCC27525DSDR	ACTIVE	SON	DSD	8	3000	RoHS & Green	NIPDAU	Level-2-260C-1 YEAR	-40 to 140	27525	<a href="#">Samples</a>
UCC27525DSDT	ACTIVE	SON	DSD	8	250	RoHS & Green	NIPDAU	Level-2-260C-1 YEAR	-40 to 140	27525	<a href="#">Samples</a>
UCC27526DSDR	ACTIVE	SON	DSD	8	3000	RoHS & Green	NIPDAU	Level-2-260C-1 YEAR	-40 to 140	SCB	<a href="#">Samples</a>

Orderable Device	Status (1)	Package Type	Package Drawing	Pins	Package Qty	Eco Plan (2)	Lead finish/ Ball material (6)	MSL Peak Temp (3)	Op Temp (°C)	Device Marking (4/5)	Samples
UCC27526DSDT	ACTIVE	SON	DSD	8	250	RoHS & Green	NIPDAU	Level-2-260C-1 YEAR	-40 to 140	SCB	Samples

(1) The marketing status values are defined as follows:

**ACTIVE:** Product device recommended for new designs.

**LIFEBUY:** TI has announced that the device will be discontinued, and a lifetime-buy period is in effect.

**NRND:** Not recommended for new designs. Device is in production to support existing customers, but TI does not recommend using this part in a new design.

**PREVIEW:** Device has been announced but is not in production. Samples may or may not be available.

**OBSOLETE:** TI has discontinued the production of the device.

(2) **RoHS:** TI defines "RoHS" to mean semiconductor products that are compliant with the current EU RoHS requirements for all 10 RoHS substances, including the requirement that RoHS substance do not exceed 0.1% by weight in homogeneous materials. Where designed to be soldered at high temperatures, "RoHS" products are suitable for use in specified lead-free processes. TI may reference these types of products as "Pb-Free".

**RoHS Exempt:** TI defines "RoHS Exempt" to mean products that contain lead but are compliant with EU RoHS pursuant to a specific EU RoHS exemption.

**Green:** TI defines "Green" to mean the content of Chlorine (Cl) and Bromine (Br) based flame retardants meet JS709B low halogen requirements of  $\leq 1000$ ppm threshold. Antimony trioxide based flame retardants must also meet the  $\leq 1000$ ppm threshold requirement.

(3) MSL, Peak Temp. - The Moisture Sensitivity Level rating according to the JEDEC industry standard classifications, and peak solder temperature.

(4) There may be additional marking, which relates to the logo, the lot trace code information, or the environmental category on the device.

(5) Multiple Device Markings will be inside parentheses. Only one Device Marking contained in parentheses and separated by a "~" will appear on a device. If a line is indented then it is a continuation of the previous line and the two combined represent the entire Device Marking for that device.

(6) Lead finish/Ball material - Orderable Devices may have multiple material finish options. Finish options are separated by a vertical ruled line. Lead finish/Ball material values may wrap to two lines if the finish value exceeds the maximum column width.

**Important Information and Disclaimer:** The information provided on this page represents TI's knowledge and belief as of the date that it is provided. TI bases its knowledge and belief on information provided by third parties, and makes no representation or warranty as to the accuracy of such information. Efforts are underway to better integrate information from third parties. TI has taken and continues to take reasonable steps to provide representative and accurate information but may not have conducted destructive testing or chemical analysis on incoming materials and chemicals. TI and TI suppliers consider certain information to be proprietary, and thus CAS numbers and other limited information may not be available for release.

In no event shall TI's liability arising out of such information exceed the total purchase price of the TI part(s) at issue in this document sold by TI to Customer on an annual basis.

## TAPE AND REEL INFORMATION

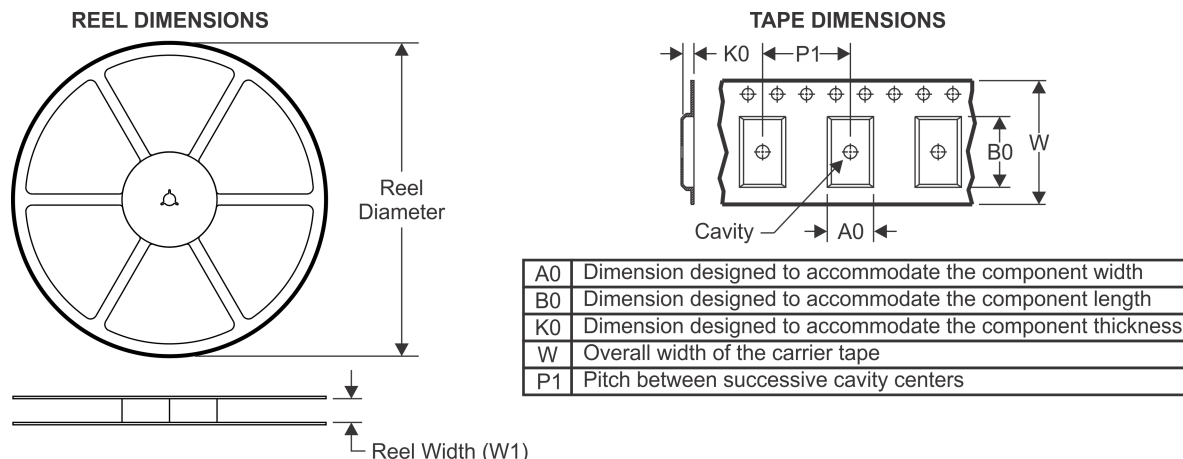

### QUADRANT ASSIGNMENTS FOR PIN 1 ORIENTATION IN TAPE



\*All dimensions are nominal

Device	Package Type	Package Drawing	Pins	SPQ	Reel Diameter (mm)	Reel Width W1 (mm)	A0 (mm)	B0 (mm)	K0 (mm)	P1 (mm)	W (mm)	Pin1 Quadrant
UCC27523DGNR	HVSSOP	DGN	8	2500	330.0	12.4	5.3	3.4	1.4	8.0	12.0	Q1
UCC27523DR	SOIC	D	8	2500	330.0	12.4	6.4	5.2	2.1	8.0	12.0	Q1
UCC27523DSDR	SON	DSD	8	3000	330.0	12.4	3.3	3.3	1.1	8.0	12.0	Q2
UCC27523DSDT	SON	DSD	8	250	180.0	12.4	3.3	3.3	1.1	8.0	12.0	Q2
UCC27524DGNR	HVSSOP	DGN	8	2500	330.0	12.4	5.3	3.4	1.4	8.0	12.0	Q1
UCC27524DR	SOIC	D	8	2500	330.0	12.4	6.4	5.2	2.1	8.0	12.0	Q1
UCC27524DSDR	SON	DSD	8	3000	330.0	12.4	3.3	3.3	1.1	8.0	12.0	Q2
UCC27524DSDT	SON	DSD	8	250	180.0	12.4	3.3	3.3	1.1	8.0	12.0	Q2
UCC27525DGNR	HVSSOP	DGN	8	2500	330.0	12.4	5.3	3.4	1.4	8.0	12.0	Q1
UCC27525DR	SOIC	D	8	2500	330.0	12.4	6.4	5.2	2.1	8.0	12.0	Q1
UCC27525DSDR	SON	DSD	8	3000	330.0	12.4	3.3	3.3	1.1	8.0	12.0	Q2
UCC27525DSDT	SON	DSD	8	250	180.0	12.4	3.3	3.3	1.1	8.0	12.0	Q2
UCC27526DSDR	SON	DSD	8	3000	330.0	12.4	3.3	3.3	1.1	8.0	12.0	Q2

**TAPE AND REEL BOX DIMENSIONS**

\*All dimensions are nominal

Device	Package Type	Package Drawing	Pins	SPQ	Length (mm)	Width (mm)	Height (mm)
UCC27523DGNR	HVSSOP	DGN	8	2500	364.0	364.0	27.0
UCC27523DR	SOIC	D	8	2500	853.0	449.0	35.0
UCC27523DSDR	SON	DSD	8	3000	367.0	367.0	35.0
UCC27523DSDT	SON	DSD	8	250	210.0	185.0	35.0
UCC27524DGNR	HVSSOP	DGN	8	2500	364.0	364.0	27.0
UCC27524DR	SOIC	D	8	2500	853.0	449.0	35.0
UCC27524DSDR	SON	DSD	8	3000	367.0	367.0	35.0
UCC27524DSDT	SON	DSD	8	250	210.0	185.0	35.0
UCC27525DGNR	HVSSOP	DGN	8	2500	364.0	364.0	27.0
UCC27525DR	SOIC	D	8	2500	853.0	449.0	35.0
UCC27525DSDR	SON	DSD	8	3000	367.0	367.0	35.0
UCC27525DSDT	SON	DSD	8	250	210.0	185.0	35.0
UCC27526DSDR	SON	DSD	8	3000	367.0	367.0	35.0

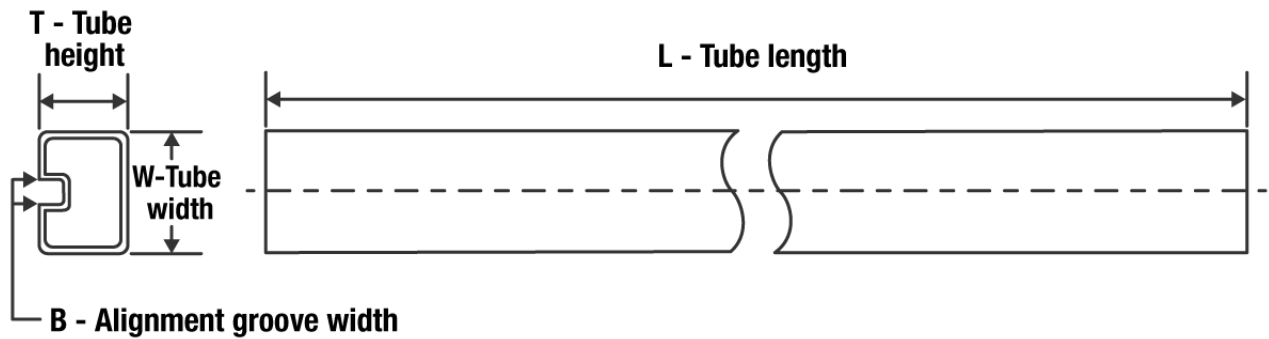
**TUBE**

\*All dimensions are nominal

Device	Package Name	Package Type	Pins	SPQ	L (mm)	W (mm)	T (μm)	B (mm)
UCC27523D	D	SOIC	8	75	506.6	8	3940	4.32
UCC27523DGN	DGN	HVSSOP	8	80	330	6.55	500	2.88
UCC27524D	D	SOIC	8	75	506.6	8	3940	4.32
UCC27524DGN	DGN	HVSSOP	8	80	330	6.55	500	2.88
UCC27524P	P	PDIP	8	50	506	13.97	11230	4.32
UCC27525D	D	SOIC	8	75	506.6	8	3940	4.32
UCC27525DGN	DGN	HVSSOP	8	80	330	6.55	500	2.88

## GENERIC PACKAGE VIEW

**DSD 8**

**WSON - 0.8 mm max height**

**3 X 3, 0.8 mm pitch**

PLASTIC QUAD FLATPACK - NO LEAD

This image is a representation of the package family, actual package may vary.  
Refer to the product data sheet for package details.

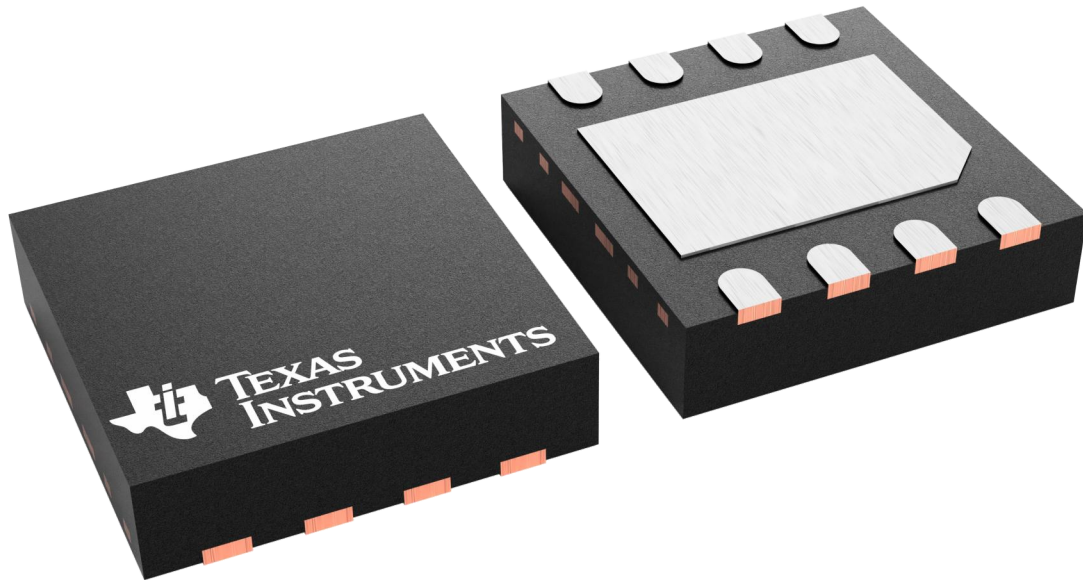

4227007/A

# DSD0008B

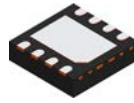

# PACKAGE OUTLINE

## WSON - 0.8 mm max height

PLASTIC SMALL OUTLINE - NO LEAD

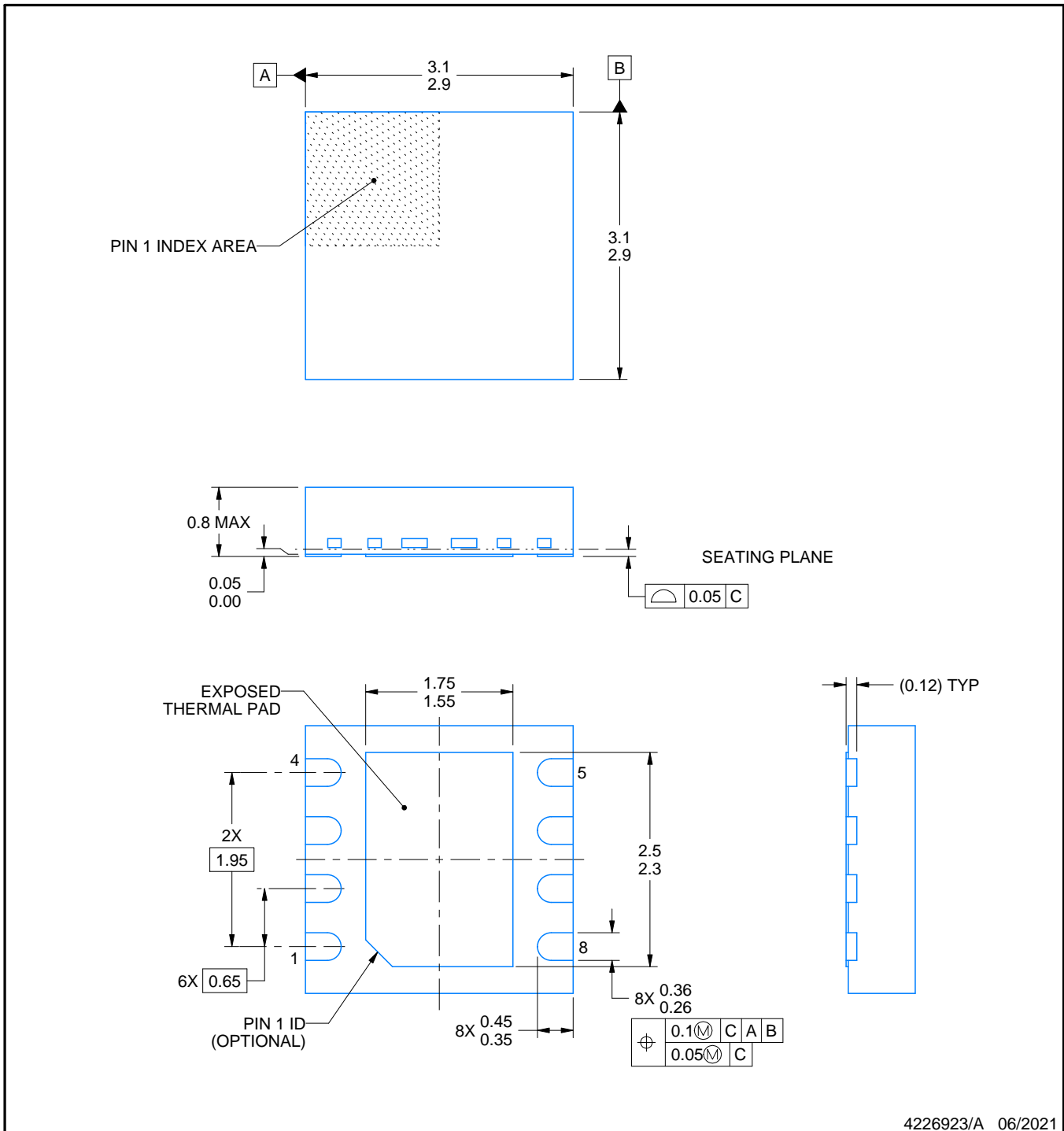

4226923/A 06/2021

### NOTES:

1. All linear dimensions are in millimeters. Any dimensions in parenthesis are for reference only. Dimensioning and tolerancing per ASME Y14.5M.
2. This drawing is subject to change without notice.
3. The package thermal pad must be soldered to the printed circuit board for thermal and mechanical performance.



# EXAMPLE STENCIL DESIGN

DSD0008B

WSON - 0.8 mm max height

PLASTIC SMALL OUTLINE - NO LEAD

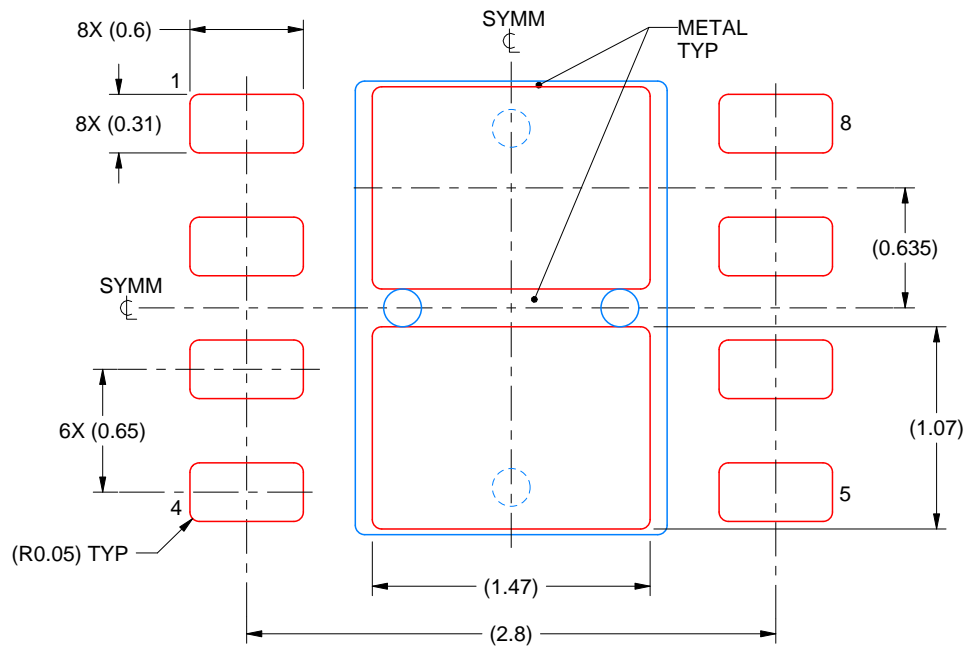

SOLDER PASTE EXAMPLE  
BASED ON 0.125 mm THICK STENCIL

EXPOSED PAD  
82% PRINTED SOLDER COVERAGE BY AREA  
SCALE:25X

4226923/A 06/2021

NOTES: (continued)

6. Laser cutting apertures with trapezoidal walls and rounded corners may offer better paste release. IPC-7525 may have alternate design recommendations.

## GENERIC PACKAGE VIEW

**DGN 8**

**PowerPAD VSSOP - 1.1 mm max height**

3 x 3, 0.65 mm pitch

SMALL OUTLINE PACKAGE

This image is a representation of the package family, actual package may vary.  
Refer to the product data sheet for package details.

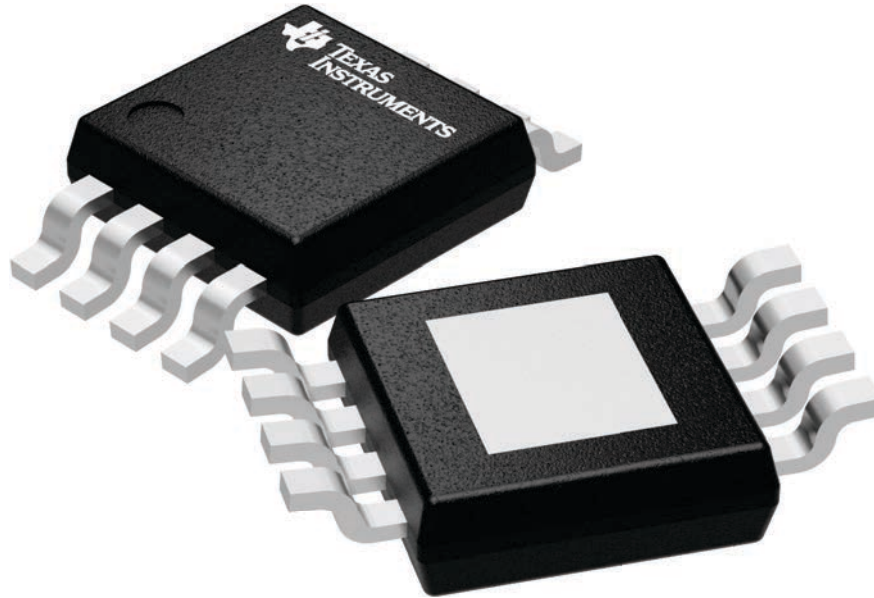

4225482/A

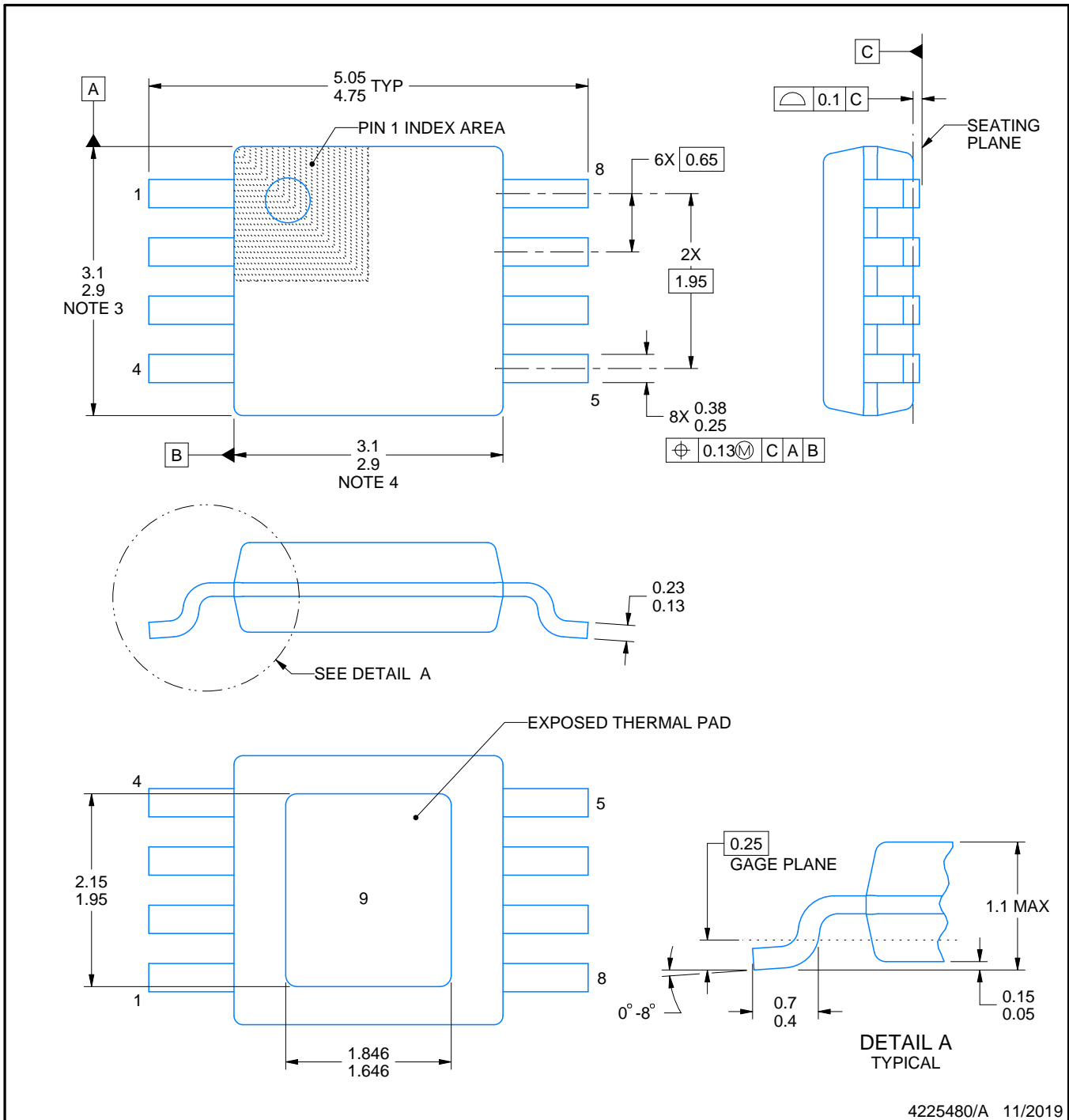
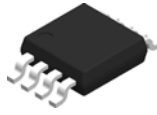

NOTES:

PowerPAD is a trademark of Texas Instruments.

1. All linear dimensions are in millimeters. Any dimensions in parenthesis are for reference only. Dimensioning and tolerancing per ASME Y14.5M.
2. This drawing is subject to change without notice.
3. This dimension does not include mold flash, protrusions, or gate burrs. Mold flash, protrusions, or gate burrs shall not exceed 0.15 mm per side.
4. This dimension does not include interlead flash. Interlead flash shall not exceed 0.25 mm per side.
5. Reference JEDEC registration MO-187.

# EXAMPLE BOARD LAYOUT

DGN0008G

PowerPAD™ VSSOP - 1.1 mm max height

SMALL OUTLINE PACKAGE

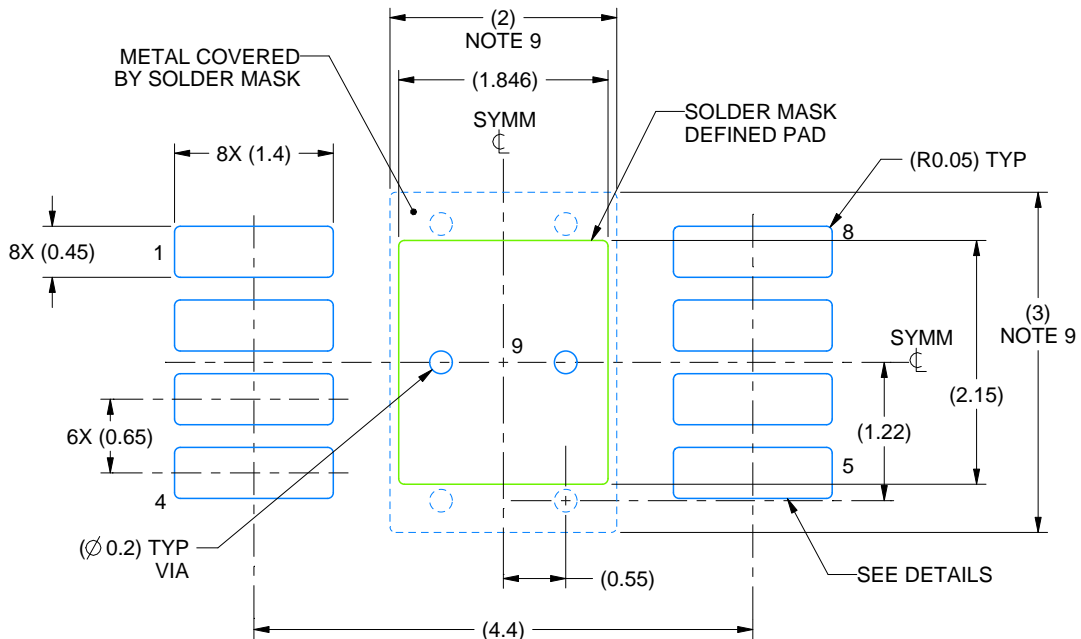

LAND PATTERN EXAMPLE  
EXPOSED METAL SHOWN  
SCALE: 15X



SOLDER MASK DETAILS

4225480/A 11/2019

NOTES: (continued)

6. Publication IPC-7351 may have alternate designs.
7. Solder mask tolerances between and around signal pads can vary based on board fabrication site.
8. Vias are optional depending on application, refer to device data sheet. If any vias are implemented, refer to their locations shown on this view. It is recommended that vias under paste be filled, plugged or tented.
9. Size of metal pad may vary due to creepage requirement.

# EXAMPLE STENCIL DESIGN

DGN0008G

PowerPAD™ VSSOP - 1.1 mm max height

SMALL OUTLINE PACKAGE

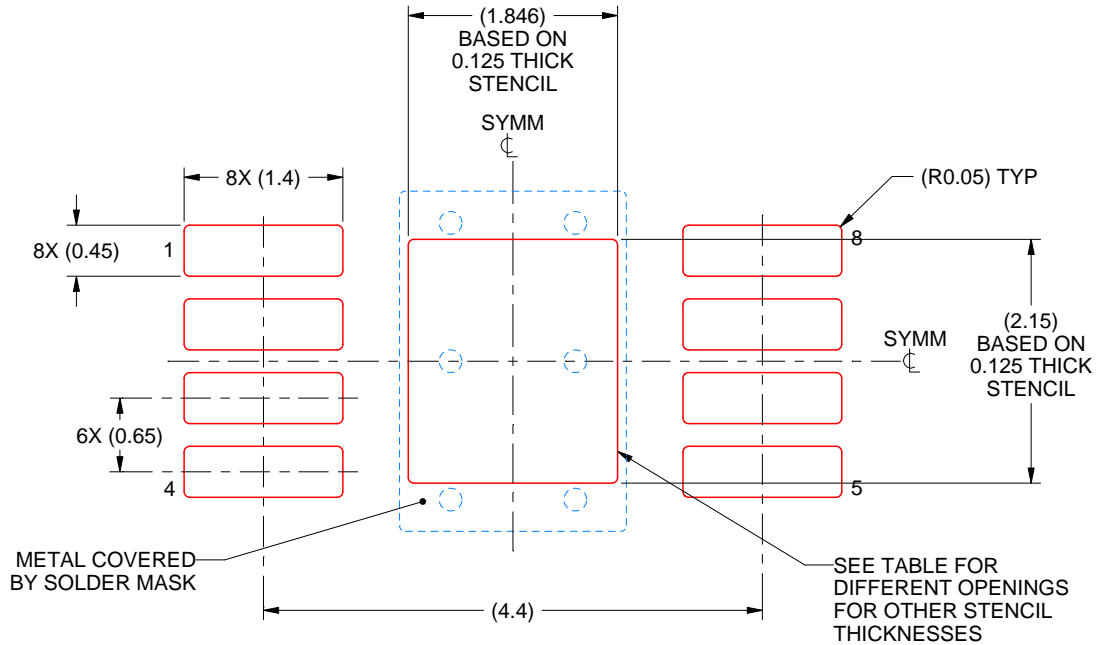

**SOLDER PASTE EXAMPLE**  
EXPOSED PAD 9:  
100% PRINTED SOLDER COVERAGE BY AREA  
SCALE: 15X

STENCIL THICKNESS	SOLDER STENCIL OPENING
0.1	2.06 X 2.40
0.125	1.846 X 2.15 (SHOWN)
0.15	1.69 X 1.96
0.175	1.56 X 1.82

4225480/A 11/2019

NOTES: (continued)

10. Laser cutting apertures with trapezoidal walls and rounded corners may offer better paste release. IPC-7525 may have alternate design recommendations.
11. Board assembly site may have different recommendations for stencil design.



D0008A

# PACKAGE OUTLINE

SOIC - 1.75 mm max height

SMALL OUTLINE INTEGRATED CIRCUIT



4214825/C 02/2019

NOTES:

1. Linear dimensions are in inches [millimeters]. Dimensions in parenthesis are for reference only. Controlling dimensions are in inches. Dimensioning and tolerancing per ASME Y14.5M.
2. This drawing is subject to change without notice.
3. This dimension does not include mold flash, protrusions, or gate burrs. Mold flash, protrusions, or gate burrs shall not exceed  $.006$  [0.15] per side.
4. This dimension does not include interlead flash.
5. Reference JEDEC registration MS-012, variation AA.

# EXAMPLE BOARD LAYOUT

D0008A

SOIC - 1.75 mm max height

SMALL OUTLINE INTEGRATED CIRCUIT



LAND PATTERN EXAMPLE  
EXPOSED METAL SHOWN  
SCALE:8X



SOLDER MASK DETAILS

4214825/C 02/2019

NOTES: (continued)

- 6. Publication IPC-7351 may have alternate designs.
- 7. Solder mask tolerances between and around signal pads can vary based on board fabrication site.

# EXAMPLE STENCIL DESIGN

D0008A

SOIC - 1.75 mm max height

SMALL OUTLINE INTEGRATED CIRCUIT



SOLDER PASTE EXAMPLE  
BASED ON .005 INCH [0.125 MM] THICK STENCIL  
SCALE:8X

4214825/C 02/2019

NOTES: (continued)

8. Laser cutting apertures with trapezoidal walls and rounded corners may offer better paste release. IPC-7525 may have alternate design recommendations.
9. Board assembly site may have different recommendations for stencil design.

P (R-PDIP-T8)

PLASTIC DUAL-IN-LINE PACKAGE



- NOTES:
- A. All linear dimensions are in inches (millimeters).
  - B. This drawing is subject to change without notice.
  - C. Falls within JEDEC MS-001 variation BA.

## 重要声明和免责声明

TI“按原样”提供技术和可靠性数据（包括数据表）、设计资源（包括参考设计）、应用或其他设计建议、网络工具、安全信息和其他资源，不保证没有瑕疵且不做任何明示或暗示的担保，包括但不限于对适销性、某特定用途方面的适用性或不侵犯任何第三方知识产权的暗示担保。

这些资源可供使用 TI 产品进行设计的熟练开发人员使用。您将自行承担以下全部责任：(1) 针对您的应用选择合适的 TI 产品，(2) 设计、验证并测试您的应用，(3) 确保您的应用满足相应标准以及任何其他功能安全、信息安全、监管或其他要求。

这些资源如有变更，恕不另行通知。TI 授权您仅可将这些资源用于研发本资源所述的 TI 产品的应用。严禁对这些资源进行其他复制或展示。您无权使用任何其他 TI 知识产权或任何第三方知识产权。您应全额赔偿因在这些资源的使用中对 TI 及其代表造成的任何索赔、损害、成本、损失和债务，TI 对此概不负责。

TI 提供的产品受 [TI 的销售条款](#) 或 [ti.com](#) 上其他适用条款/TI 产品随附的其他适用条款的约束。TI 提供这些资源并不会扩展或以其他方式更改 TI 针对 TI 产品发布的适用的担保或担保免责声明。

TI 反对并拒绝您可能提出的任何其他或不同的条款。

邮寄地址：Texas Instruments, Post Office Box 655303, Dallas, Texas 75265

Copyright © 2022，德州仪器 (TI) 公司