

UCC53x0 单通道隔离式栅极驱动器

1 特性

- 特性选项
 - 分离输出 (UCC53x0S)
 - 以 GND2 为基准的 UVLO (UCC53x0E)
 - 米勒钳位选项 (UCC53x0M)
- 8 引脚 D (4mm 爬电) 和 DWV (8.5mm 爬电) 封装
- 60ns (典型值) 传播延迟
- 100kV/μs 最低 CMTI
- 隔离层寿命达 40 年以上
- 3V 至 15V 输入电源电压
- 高达 33V 的驱动器电源电压
 - 8V 和 12V UVLO 选项
- 输入引脚具有负 5V 电压处理能力
- 安全相关认证:
 - 7000V_{PK} 隔离 DWV (计划) 和 4242V_{PK} 隔离 D (符合 DIN V VDE V 0884-11:2017-01 和 DIN EN 61010-1 标准)
 - 5000V_{RMS} DWV 和 3000V_{RMS} D 隔离等级长达 1 分钟 (符合 UL 1577 标准)
 - 符合 GB4943.1-2011 D 和 DWV 标准的 CQC 认证 (计划)
- CMOS 输入
- 工作温度范围: -40°C 至 +125°C

2 应用

- 电机驱动器
- 高压直流到直流转换器
- UPS 和 PSU
- 混合动力汽车 (HEV) 和电动车 (EV) 电源模块
- 光伏逆变器

4 功能框图 (S、E 和 M 版本)

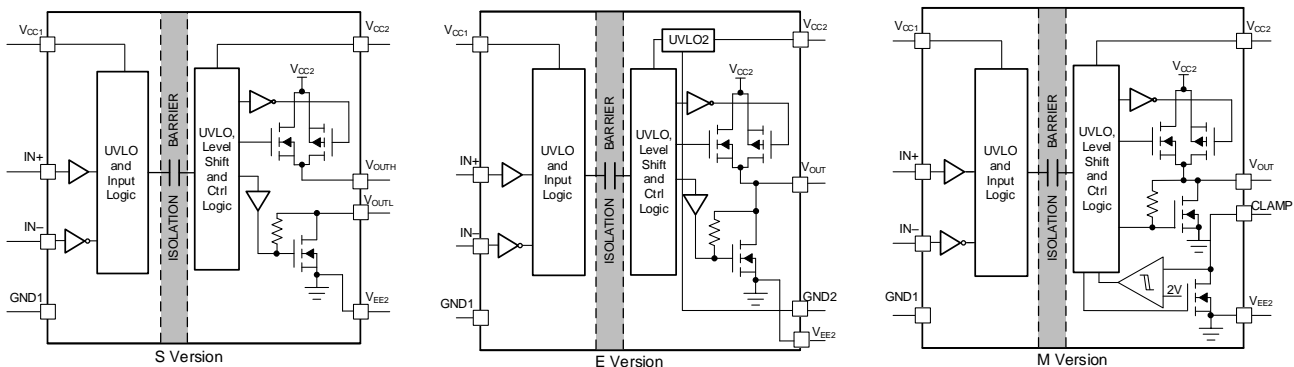

Copyright © 2018, Texas Instruments Incorporated

3 说明

UCC53x0 是一系列单通道隔离式栅极驱动器，用于驱动 MOSFET、IGBT、SiC MOSFET 和 GaN FET (UCC5350SBD)。UCC53x0S 提供分离输出，可分别控制上升和下降时间。UCC53x0M 将晶体管的栅极连接到内部钳位，以防止米勒电流造成假接通。

UCC53x0E 的 UVLO2 以 GND2 为基准，以获取真实的 UVLO 读数。

UCC53x0 采用 4mm SOIC-8 (D) 或 8.5mm SOIC-8 (DWV) 封装，可分别支持高达 3kV_{RMS} 和 5kV_{RMS} 的隔离电压。凭借这些各种不同的选项，UCC53x0 系列非常适合电机驱动器和工业电源。

与光耦合器相比，UCC53x0 系列的部件间偏移更低，传播延迟更小，工作温度更高，并且 CMTI 更高。

器件信息(1)

可订购部件号	最低拉电流和灌电流	说明
UCC5310MC	2.4A 和 1.1A	米勒钳位
UCC5320SC	2.4A 和 2.2A	分离输出
UCC5320EC	2.4A 和 2.2A	UVLO 以 IGBT 发射极为基准
UCC5350MC	5A 和 5A	米勒钳位
UCC5350SB	5A 和 5A	具有 8V UVLO 的分离输出
UCC5390SC	10A 和 10A	分离输出
UCC5390EC	10A 和 10A	UVLO 以 IGBT 发射极为基准

(1) 如需了解所有可用封装，请参阅数据表末尾的可订购产品附录。

(2) 有关器件的详细比较，请参见 [器件比较表](#)



目录

1	特性	1	Configuration	22
2	应用	1	10 Detailed Description	25
3	说明	1	10.1 Overview	25
4	功能框图 (S、E 和 M 版本)	1	10.2 Functional Block Diagram	25
5	修订历史记录	3	10.3 Feature Description	27
6	Device Comparison Table	4	10.4 Device Functional Modes	31
7	Pin Configuration and Function	5	11 Application and Implementation	33
8	Specifications	6	11.1 Application Information	33
8.1	Absolute Maximum Ratings	6	11.2 Typical Application	33
8.2	ESD Ratings	6	12 Power Supply Recommendations	39
8.3	Recommended Operating Conditions	6	13 Layout	40
8.4	Thermal Information	7	13.1 Layout Guidelines	40
8.5	Power Ratings	7	13.2 Layout Example	41
8.6	Insulation Specifications for D Package	8	13.3 PCB Material	43
8.7	Insulation Specifications for DWV Package	9	14 器件和文档支持	44
8.8	Safety-Related Certifications For D Package	10	14.1 文档支持	44
8.9	Safety-Related Certifications For DWV Package	10	14.2 认证	44
8.10	Safety Limiting Values	10	14.3 相关链接	44
8.11	Electrical Characteristics	11	14.4 接收文档更新通知	44
8.12	Switching Characteristics	13	14.5 社区资源	44
8.13	Insulation Characteristics Curves	14	14.6 商标	44
8.14	Typical Characteristics	15	14.7 静电放电警告	44
9	Parameter Measurement Information	22	14.8 术语表	44
9.1	Propagation Delay, Inverting, and Noninverting		15 机械、封装和可订购信息	45

5 修订历史记录

注：之前版本的页码可能与当前版本有所不同。

Changes from Revision E (October 2018) to Revision F	Page
• 已删除 从第 2 个项目中删除了“(UCC5390EC)”。现在有三个已发行的宽体器件	1
• 已添加 在“安全相关认证”中添加了“DIN EN 61010-1”	1
• 已添加 在整个“安全相关认证”项目中添加了“(计划)”	1
• 已更改 在“说明”中使用开关类型信息更改了“引脚配置和驱动强度 型号”	1
• Changed creepage and clearance from 9 mm to 8.5 mm in Insulation Specifications and throughout datasheet	9
• Added VDE and CQC certification for D package and UL file number for DWV package	10
• Changed test condition for V_{OH}	11
• 已更改 a minor detail to the UCC53x0M figures	29
• 已更改 typical application circuit for E Version to include capacitors on negative bias	34

Changes from Revision D (May 2018) to Revision E	Page
• Changed UCC5310 DWV package from Preview to Final.	4
• Changed UCC5320 DWV package from Preview to Final.	4

Changes from Revision C (February 2018) to Revision D	Page
• 已更改 将 UCC5390EC 的销售状态从“预览”更改成了“生产”。	1

Changes from Revision B (August 2017) to Revision C	Page
• 已添加 将 UCC5350SBD、UCC5320SCDWV、UCC5310MCDWV 和 UCC5390ECDWV 器件添加至数据表	1
• 已更改 特性、应用、说明和功能框图，以包括 E 和 M 版本，以及 DWV 封装信息。	1
• Added UCC5350SB to the pin configuration and function	5
• Added Minimum Storage Temperature	6
• Changed from VDE V 0884-10 to VDE V 0884-11 in insulation specification and safety-related certification table	8
• Changed Safety Limiting Values	10
• Deleted test conditions for Supply Currents	11
• 已添加 Typical Curves and Test Conditions to include UCC5390 and UCC5350 information	15
• 已删除 Device I/O Figure	32
• 已更改 ESD Figure	32
• 已添加 在认证部分添加 UL 在线认证目录	44

Changes from Revision A (June 2017) to Revision B	Page
• 已更改 最低环境工作温度为 -55°C 至 -40°C	1

Changes from Original (June 2017) to Revision A	Page
• 已删除 从标题中删除了可用于未来 10A 器件的 17A 规格	1

6 Device Comparison Table

DEVICE OPTION ⁽¹⁾	PACKAGE	MINIMUM SOURCE CURRENT	MINIMUM SINK CURRENT	PIN CONFIGURATION	UVLO	ISOLATION RATING
UCC5310MC	D	2.4 A	1.1 A	Miller clamp	12 V	3-kV _{RMS}
	DWV					5-kV _{RMS}
UCC5320EC	D	2.4 A	2.2 A	UVLO with reference to GND2	12 V	3-kV _{RMS}
UCC5320SC	D	2.4 A	2.2 A	Split output	12 V	3-kV _{RMS}
	DWV					5-kV _{RMS}
UCC5350MC	D	5 A	5 A	Miller clamp	12 V	3-kV _{RMS}
UCC5350SB	D	5 A	5 A	Split Output	8 V	3-kV _{RMS}
UCC5390EC	D	10 A	10 A	UVLO with reference to GND2	12 V	3-kV _{RMS}
	DWV					5-kV _{RMS}
UCC5390SC	D	10 A	10 A	Split output	12 V	3-kV _{RMS}

(1) The S, E, and M suffixes are part of the orderable part number. See the [机械、封装和可订购信息](#) section for the full orderable part number.

7 Pin Configuration and Function

UCC5320S, UCC5350SB, and UCC5390S
8-Pin SOIC
Top View

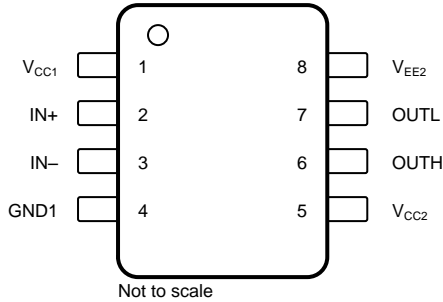

UCC5310M and UCC5350M
8-Pin SOIC
Top View

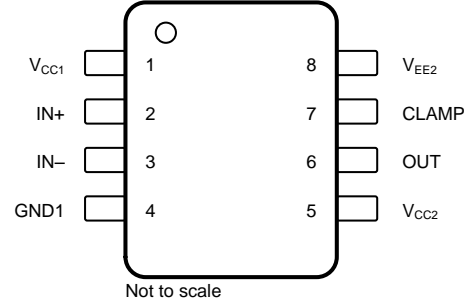

UCC5320E and UCC5390E
8-Pin SOIC
Top View

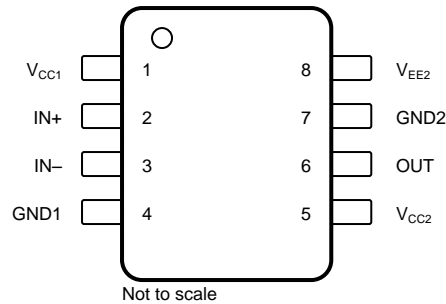

Pin Functions

NAME	PIN NO.			TYPE	DESCRIPTION
	UCC53x0S	UCC53x0M	UCC53x0E		
CLAMP	—	7	—	I	Active Miller-clamp input found on the UCC53x0M used to prevent false turnon of the power switches.
GND1	4	4	4	G	Input ground. All signals on the input side are referenced to this ground.
GND2	—	—	7	G	Gate-drive common pin. Connect this pin to the IGBT emitter. UVLO referenced to GND2 in the UCC53x0E.
IN+	2	2	2	I	Noninverting gate-drive voltage-control input. The IN+ pin has a CMOS input threshold. This pin is pulled low internally if left open. Use 表 4 to understand the input and output logic of these devices.
IN-	3	3	3	I	Inverting gate-drive voltage control input. The IN- pin has a CMOS input threshold. This pin is pulled high internally if left open. Use 表 4 to understand the input and output logic of these devices.
OUT	—	6	6	O	Gate-drive output for UCC53x0E and UCC53x0M versions.
OUTH	6	—	—	O	Gate-drive pullup output found on the UCC53x0S.
OUTL	7	—	—	O	Gate-drive pulldown output found on the UCC53x0S.
V _{CC1}	1	1	1	P	Input supply voltage. Connect a locally decoupled capacitor to GND. Use a low-ESR or ESL capacitor located as close to the device as possible.
V _{CC2}	5	5	5	P	Positive output supply rail. Connect a locally decoupled capacitor to V _{EE2} . Use a low-ESR or ESL capacitor located as close to the device as possible.
V _{EE2}	8	8	8	P	Negative output supply rail for E version, and GND for S and M versions. Connect a locally decoupled capacitor to GND2 for E version. Use a low-ESR or ESL capacitor located as close to the device as possible.

8 Specifications

8.1 Absolute Maximum Ratings

Over operating free air temperature range (unless otherwise noted)⁽¹⁾

		MIN	MAX	UNIT
Input bias pin supply voltage	$V_{CC1} - GND1$	$GND1 - 0.3$	18	V
Driver bias supply	$V_{CC2} - V_{EE2}$	-0.3	35	V
V_{EE2} bipolar supply voltage for E version	$V_{EE2} - GND2$	-17.5	0.3	V
Output signal voltage	$V_{OUTH} - V_{EE2}, V_{OUTL} - V_{EE2}, V_{OUT} - V_{EE2}, V_{CLAMP} - V_{EE2}$	$V_{EE2} - 0.3$	$V_{CC2} + 0.3$	V
Input signal voltage	$V_{IN+} - GND1, V_{IN-} - GND1$	$GND1 - 5$	$V_{CC1} + 0.3$	V
Junction temperature, T_J ⁽²⁾		-40	150	°C
Storage temperature, T_{stg}		-65	150	°C

- (1) Stresses beyond those listed under *Absolute Maximum Ratings* may cause permanent damage to the device. These are stress ratings only, which do not imply functional operation of the device at these or any other conditions beyond those indicated under *Recommended Operating Conditions*. Exposure to absolute-maximum-rated conditions for extended periods may affect device reliability.
- (2) To maintain the recommended operating conditions for T_J , see the [Thermal Information](#).

8.2 ESD Ratings

		VALUE	UNIT
$V_{(ESD)}$	Electrostatic discharge		
	Human body model (HBM), per ANSI/ESDA/JEDEC JS-001 ⁽¹⁾	±4000	V
Charged device model (CDM), per JEDEC specification JESD22-C101 ⁽²⁾	±1500		

- (1) JEDEC document JEP155 states that 500-V HBM allows safe manufacturing with a standard ESD control process.
- (2) JEDEC document JEP157 states that 250-V CDM allows safe manufacturing with a standard ESD control process.

8.3 Recommended Operating Conditions

Over operating free-air temperature range (unless otherwise noted)

		MIN	NOM	MAX	UNIT
V_{CC1}	Supply voltage, input side	3		15	V
V_{CC2}	Positive supply voltage output side ($V_{CC2} - V_{EE2}$), UCC53x0	13.2		33	V
V_{CC2}	Positive supply voltage output side ($V_{CC2} - V_{EE2}$), UCC5350SBD	9.5		33	V
V_{EE2}	Bipolar supply voltage for E version ($V_{EE2} - GND2$), UCC53x0	-16		0	V
V_{SUP2}	Total supply voltage output side ($V_{CC2} - V_{EE2}$), UCC53x0	13.2		33	V
T_A	Ambient temperature	-40		125	°C

8.4 Thermal Information

THERMAL METRIC ⁽¹⁾	UCC53x0		UNIT
	D (SOIC)	DWV (SOIC)	
	8 PINS	8 PINS	
$R_{\theta JA}$ Junction-to-ambient thermal resistance	109.5	119.8	°C/W
$R_{\theta JC(top)}$ Junction-to-case (top) thermal resistance	43.1	64.1	°C/W
$R_{\theta JB}$ Junction-to-board thermal resistance	51.2	65.4	°C/W
Ψ_{JT} Junction-to-top characterization parameter	18.3	37.6	°C/W
Ψ_{JB} Junction-to-board characterization parameter	50.7	63.7	°C/W

(1) For more information about traditional and new thermal metrics, see the [Semiconductor and IC Package Thermal Metrics](#) application report.

8.5 Power Ratings

PARAMETER	TEST CONDITIONS	MIN	TYP	MAX	UNIT
D Package					
P_D Maximum power dissipation on input and output	$V_{CC1} = 15\text{ V}$, $V_{CC2} = 15\text{ V}$, $f = 2.1\text{-MHz}$, 50% duty cycle, square wave, 2.2-nF load			1.14	W
P_{D1} Maximum input power dissipation				0.05	W
P_{D2} Maximum output power dissipation				1.09	W
DWV Package					
P_D Maximum power dissipation on input and output	$V_{CC1} = 15\text{ V}$, $V_{CC2} = 15\text{ V}$, $f = 1.9\text{-MHz}$, 50% duty cycle, square wave, 2.2-nF load			1.04	W
P_{D1} Maximum input power dissipation				0.05	W
P_{D2} Maximum output power dissipation				0.99	W

8.6 Insulation Specifications for D Package

PARAMETER		TEST CONDITIONS	VALUE	UNIT
			D	
CLR	External Clearance ⁽¹⁾	Shortest pin-to-pin distance through air	≥ 4	mm
CPG	External Creepage ⁽¹⁾	Shortest pin-to-pin distance across the package surface	≥ 4	mm
DTI	Distance through the insulation	Minimum internal gap (internal clearance)	> 21	μm
CTI	Comparative tracking index	DIN EN 60112 (VDE 0303–11); IEC 60112	> 600	V
	Material Group	According to IEC 60664–1	I	
Overvoltage category per IEC 60664-1		Rated mains voltage ≤ 150 V _{RMS}	I-IV	
		Rated mains voltage ≤ 300 V _{RMS}	I-III	
DIN V VDE 0884–11: 2017–01⁽²⁾				
V _{IORM}	Maximum repetitive peak isolation voltage	AC voltage (bipolar)	990	V _{PK}
V _{IOWM}	Maximum isolation working voltage	AC voltage (sine wave); time dependent dielectric breakdown (TDDb) test;	700	V _{RMS}
V _{IOTM}	Maximum transient isolation voltage	V _{TEST} = V _{IOTM} , t = 60 s (qualification) ; V _{TEST} = 1.2 × V _{IOTM} , t = 1 s (100% production)	4242	V _{PK}
V _{IOSM}	Maximum surge isolation voltage ⁽³⁾	Test method per IEC 62368-1, 1.2/50-μs waveform, V _{TEST} = 1.3 × V _{IOSM} (qualification)	4242	V _{PK}
q _{pd}	Apparent charge ⁽⁴⁾	Method a: After I/O safety test subgroup 2/3, V _{ini} = V _{IOTM} , t _{ini} = 60 s V _{pd(m)} = 1.2 × V _{IORM} , t _m = 10 s	≤ 5	pC
		Method a: After environmental tests subgroup 1, V _{ini} = V _{IOTM} , t _{ini} = 60 s; V _{pd(m)} = 1.2 × V _{IORM} , t _m = 10 s	≤ 5	
		Method b1: At routine test (100% production) and preconditioning (type test), V _{ini} = 1.2 × V _{IOTM} , t _{ini} = 1 s; V _{pd(m)} = 1.5 × V _{IORM} , t _m = 1 s	≤ 5	
C _{IO}	Barrier capacitance, input to output ⁽⁵⁾	V _{IO} = 0.4 × sin (2πft), f = 1 MHz	1.2	pF
R _{IO}	Isolation resistance, input to output ⁽⁵⁾	V _{IO} = 500 V, T _A = 25°C	> 10 ¹²	Ω
		V _{IO} = 500 V, 100°C ≤ T _A ≤ 125°C	> 10 ¹¹	
		V _{IO} = 500 V at T _S = 150°C	> 10 ⁹	
	Pollution degree		2	
	Climatic category		40/125/21	
UL 1577				
V _{ISO}	Withstand isolation voltage	V _{TEST} = V _{ISO} , t = 60 s (qualification); V _{TEST} = 1.2 × V _{ISO} , t = 1 s (100% production)	3000	V _{RMS}

- (1) Creepage and clearance requirements should be applied according to the specific equipment isolation standards of an application. Care should be taken to maintain the creepage and clearance distance of a board design to ensure that the mounting pads of the isolator on the printed-circuit board do not reduce this distance. Creepage and clearance on a printed-circuit board become equal in certain cases. Techniques such as inserting grooves, ribs, or both on a printed circuit board are used to help increase these specifications.
- (2) This coupler is suitable for basic electrical insulation only within the maximum operating ratings. Compliance with the safety ratings shall be ensured by means of suitable protective circuits.
- (3) Testing is carried out in air or oil to determine the intrinsic surge immunity of the isolation barrier.
- (4) Apparent charge is electrical discharge caused by a partial discharge (pd).
- (5) All pins on each side of the barrier tied together creating a two-pin device.

8.7 Insulation Specifications for DWV Package

PARAMETER		TEST CONDITIONS	VALUE	UNIT
			DWV	
CLR	External Clearance ⁽¹⁾	Shortest pin-to-pin distance through air	≥ 8.5	mm
CPG	External Creepage ⁽¹⁾	Shortest pin-to-pin distance across the package surface	≥ 8.5	mm
DTI	Distance through the insulation	Minimum internal gap (internal clearance)	> 21	μm
CTI	Comparative tracking index	DIN EN 60112 (VDE 0303–11); IEC 60112	> 600	V
	Material Group	According to IEC 60664–1	I	
Overvoltage category per IEC 60664-1		Rated mains voltage ≤ 600 V _{RMS}	I-III	
		Rated mains voltage ≤ 1000 V _{RMS}	I-II	
DIN V VDE 0884–11: 2017–01⁽²⁾				
V _{IORM}	Maximum repetitive peak isolation voltage	AC voltage (bipolar)	2121	V _{PK}
V _{IOWM}	Maximum isolation working voltage	AC voltage (sine wave); time dependent dielectric breakdown (TDDb) test	1500	V _{RMS}
		DC Voltage	2121	V _{DC}
V _{IOTM}	Maximum transient isolation voltage	V _{TEST} = V _{IOTM} , t = 60 s (qualification) ; V _{TEST} = 1.2 × V _{IOTM} , t = 1 s (100% production)	7000	V _{PK}
V _{IOSM}	Maximum surge isolation voltage ⁽³⁾	Test method per IEC 62368-1, 1.2/50-μs waveform, V _{TEST} = 1.6 × V _{IOSM} (qualification)	8000	V _{PK}
q _{pd}	Apparent charge ⁽⁴⁾	Method a: After I/O safety test subgroup 2/3, V _{ini} = V _{IOTM} , t _{ini} = 60 s V _{pd(m)} = 1.2 × V _{IORM} , t _m = 10 s	≤ 5	pC
		Method a: After environmental tests subgroup 1, V _{ini} = V _{IOTM} , t _{ini} = 60 s; V _{pd(m)} = 1.6 × V _{IORM} , t _m = 10 s	≤ 5	
		Method b1: At routine test (100% production) and preconditioning (type test), V _{ini} = 1.2 × V _{IOTM} , t _{ini} = 1 s; V _{pd(m)} = 1.875 × V _{IORM} , t _m = 1 s	≤ 5	
C _{IO}	Barrier capacitance, input to output ⁽⁵⁾	V _{IO} = 0.4 × sin(2πft), f = 1 MHz	1.2	pF
R _{IO}	Isolation resistance, input to output ⁽⁵⁾	V _{IO} = 500 V, T _A = 25°C	> 10 ¹²	Ω
		V _{IO} = 500 V, 100°C ≤ T _A ≤ 125°C	> 10 ¹¹	
		V _{IO} = 500 V at T _S = 150°C	> 10 ⁹	
	Pollution degree		2	
	Climatic category		40/125/21	
UL 1577				
V _{ISO}	Withstand isolation voltage	V _{TEST} = V _{ISO} , t = 60 s (qualification); V _{TEST} = 1.2 × V _{ISO} , t = 1 s (100% production)	5000	V _{RMS}

- Creepage and clearance requirements should be applied according to the specific equipment isolation standards of an application. Care should be taken to maintain the creepage and clearance distance of a board design to ensure that the mounting pads of the isolator on the printed-circuit board do not reduce this distance. Creepage and clearance on a printed-circuit board become equal in certain cases. Techniques such as inserting grooves, ribs, or both on a printed circuit board are used to help increase these specifications.
- This coupler is suitable for safe electrical insulation only within the safety ratings. Compliance with the safety ratings shall be ensured by means of suitable protective circuits.
- Testing is carried out in air or oil to determine the intrinsic surge immunity of the isolation barrier.
- Apparent charge is electrical discharge caused by a partial discharge (pd).
- All pins on each side of the barrier tied together creating a two-pin device.

8.8 Safety-Related Certifications For D Package

VDE	UL	CQC
Certified according to DIN V VDE V 0884–11:2017–01 and DIN EN 61010-1 (VDE 0411-1):2011-07	Recognized under UL 1577 Component Recognition Program	Certified according to GB 4943.1–2011
Basic Insulation Maximum Transient Isolation Overvoltage, 4242 V _{PK} ; Maximum Repetitive Peak Voltage, 990 V _{PK} ; Maximum Surge Isolation Voltage, 4242 V _{PK}	Single protection, 3000 V _{RMS}	Basic Insulation, Altitude ≤ 5000m, Tropical Climate, 700 V _{RMS} Maximum Working Voltage
Certificate Number: 40047657	File Number: E181974	Certification number: CQC18001199354

8.9 Safety-Related Certifications For DWV Package

VDE	UL	CQC
Plan to certify according to DIN V VDE V 0884–11:2017–01 and DIN EN 61010-1	Recognized under UL 1577 Component Recognition Program	Plan to certify according to GB 4943.1–2011
Reinforced Insulation Maximum Transient isolation Overvoltage, 7000 V _{PK} ; Maximum Repetitive Peak Isolation Voltage, 2121 V _{PK} ; Maximum Surge Isolation Voltage, 8000 V _{PK}	Single protection, 5000 V _{RMS}	Reinforced Insulation, Altitude ≤ 5000 m, Tropical Climate
Certification planned	File Number: E181974	Certification planned

8.10 Safety Limiting Values

Safety limiting intends to minimize potential damage to the isolation barrier upon failure of input or output circuitry.

PARAMETER	TEST CONDITIONS	MIN	TYP	MAX	UNIT
D PACKAGE					
I _S Safety output supply current	R _{θJA} = 109.5°C/W, V _{CC2} = 15 V, T _J = 150°C, T _A = 25°C, see 图 1			73	mA
	R _{θJA} = 109.5°C/W, V _{CC2} = 30 V, T _J = 150°C, T _A = 25°C, see 图 1	Output side		36	
P _S Safety output supply power	R _{θJA} = 109.5°C/W, T _J = 150°C, T _A = 25°C, see 图 3	Input side		0.05	W
		Output side		1.09	
		Total		1.14	
T _S Maximum safety temperature ⁽¹⁾				150	°C
DWV PACKAGE					
I _S Safety input, output, or supply current	R _{θJA} = 119.8°C/W, V _I = 15 V, T _J = 150°C, T _A = 25°C, see 图 2	Output side		66	mA
	R _{θJA} = 119.8°C/W, V _I = 30 V, T _J = 150°C, T _A = 25°C, see 图 2	Output side		33	
P _S Safety input, output, or total power	R _{θJA} = 119.8°C/W, T _J = 150°C, T _A = 25°C, see 图 4	Input side		0.05	W
		Output side		0.99	
		Total		1.04	
T _S Maximum safety temperature ⁽¹⁾				150	°C

(1) The maximum safety temperature, T_S, has the same value as the maximum junction temperature, T_J, specified for the device. The I_S and P_S parameters represent the safety current and safety power respectively. The maximum limits of I_S and P_S should not be exceeded. These limits vary with the ambient temperature, T_A.

The junction-to-air thermal resistance, R_{θJA}, in the [Thermal Information](#) table is that of a device installed on a high-K test board for leaded surface-mount packages. Use these equations to calculate the value for each parameter:

$$T_J = T_A + R_{\theta JA} \times P, \text{ where } P \text{ is the power dissipated in the device.}$$

$$T_{J(max)} = T_S = T_A + R_{\theta JA} \times P_S, \text{ where } T_{J(max)} \text{ is the maximum allowed junction temperature.}$$

$$P_S = I_S \times V_I, \text{ where } V_I \text{ is the maximum input voltage.}$$

8.11 Electrical Characteristics

$V_{CC1} = 3.3\text{ V}$ or 5 V , $0.1\text{-}\mu\text{F}$ capacitor from V_{CC1} to GND1, $V_{CC2} = 15\text{ V}$, $1\text{-}\mu\text{F}$ capacitor from V_{CC2} to V_{EE2} , $C_L = 100\text{-pF}$, $T_A = -40^\circ\text{C}$ to $+125^\circ\text{C}$, (unless otherwise noted)

PARAMETER		TEST CONDITIONS	MIN	TYP	MAX	UNIT
SUPPLY CURRENTS						
I_{VCC1}	Input supply quiescent current			1.67	2.4	mA
I_{VCC2}	Output supply quiescent current			1.1	1.8	mA
SUPPLY VOLTAGE UNDERVOLTAGE THRESHOLDS						
$V_{IT+(UVLO1)}$	VCC1 Positive-going UVLO threshold voltage			2.6	2.8	V
$V_{IT-(UVLO1)}$	VCC1 Negative-going UVLO threshold voltage		2.4	2.5		V
$V_{hys(UVLO1)}$	VCC1 UVLO threshold hysteresis			0.1		V
UCC5310MC, UCC5320SC, UCC5320EC, UCC5390SC, UCC5390EC, and UCC5350MC UVLO THRESHOLDS (12-V UVLO Version)						
$V_{IT+(UVLO2)}$	VCC2 Positive-going UVLO threshold voltage			12	13	V
$V_{IT-(UVLO2)}$	VCC2 Negative-going UVLO threshold voltage		10.3	11		V
$V_{hys(UVLO2)}$	VCC2 UVLO threshold voltage hysteresis			1		V
UCC5350SB UVLO THRESHOLD (8-V UVLO Version)						
$V_{IT+(UVLO2)}$	VCC2 Positive-going UVLO threshold voltage			8.7	9.4	V
$V_{IT-(UVLO2)}$	VCC2 Negative-going UVLO threshold voltage		7.3	8.0		V
$V_{hys(UVLO2)}$	VCC2 UVLO threshold voltage hysteresis			0.7		V
LOGIC I/O						
$V_{IT+(IN)}$	Positive-going input threshold voltage (IN+, IN-)			$0.55 \times V_{CC1}$	$0.7 \times V_{CC1}$	V
$V_{IT-(IN)}$	Negative-going input threshold voltage (IN+, IN-)		$0.3 \times V_{CC1}$	$0.45 \times V_{CC1}$		V
$V_{hys(IN)}$	Input hysteresis voltage (IN+, IN-)			$0.1 \times V_{CC1}$		V
I_{IH}	High-level input leakage at IN+	IN+ = V_{CC1}		40	240	μA
I_{IL}	Low-level input leakage at IN-	IN- = GND1		-240	-40	μA
		IN- = GND1 - 5 V		-310	-80	
GATE DRIVER STAGE						
V_{OH}	High-level output voltage (VCC2 - OUT) and (VCC2 - OUTH)	$I_{OUT} = -20\text{ mA}$		100	240	mV
V_{OL}	Low level output voltage (OUT and OUTL)	UCC5320SC and UCC5320EC, IN+ = low, IN- = high; $I_O = 20\text{ mA}$		9.4	13	mV
		UCC5310MC, IN+ = low, IN- = high; $I_O = 20\text{ mA}$		17	26	
		UCC5390SC and UCC5390EC, IN+ = low, IN- = high; $I_O = 20\text{ mA}$		2	3	
		UCC5350MC and UCC5350SB, IN+ = low, IN- = high; $I_O = 20\text{ mA}$		5	7	

Electrical Characteristics (continued)
 $V_{CC1} = 3.3\text{ V}$ or 5 V , $0.1\text{-}\mu\text{F}$ capacitor from V_{CC1} to GND1, $V_{CC2} = 15\text{ V}$, $1\text{-}\mu\text{F}$ capacitor from V_{CC2} to V_{EE2} , $C_L = 100\text{-pF}$, $T_A = -40^\circ\text{C}$ to $+125^\circ\text{C}$, (unless otherwise noted)

PARAMETER		TEST CONDITIONS	MIN	TYP	MAX	UNIT
I_{OH}	Peak source current	UCC5320SC and UCC5320EC, IN+ = high, IN- = low	2.4	4.3		A
		UCC5310MC, IN+ = high, IN- = low	2.4	4.3		
		UCC5390SC and UCC5390EC, IN+ = high, IN- = low	10	17		
		UCC5350MC, IN+ = high, IN- = low	5	10		
		UCC5350SB IN+ = high, IN- = low	5	8.5		
I_{OL}	Peak sink current	UCC5320SC and UCC5320EC, IN+ = low, IN- = high	2.2	4.4		A
		UCC5310MC, IN+ = low, IN- = high	1.1	2.2		
		UCC5390SC and UCC5390EC, IN+ = low, IN- = high	10	17		
		UCC5350MC, IN+ = low, IN- = high	5	10		
		UCC5350SB IN+ = low, IN- = high	5	10		
ACTIVE MILLER CLAMP (UCC53xxM only)						
V_{CLAMP}	Low-level clamp voltage	UCC5310MC, $I_{CLAMP} = 20\text{ mA}$		26	50	mV
		UCC5350MC, $I_{CLAMP} = 20\text{ mA}$		7	10	
I_{CLAMP}	Clamp low-level current	UCC5310MC, $V_{CLAMP} = V_{EE2} + 15\text{ V}$	1.1	2.2		A
		UCC5350MC, $V_{CLAMP} = V_{EE2} + 15\text{ V}$	5	10		
$I_{CLAMP(L)}$	Clamp low-level current for low output voltage	UCC5310MC, $V_{CLAMP} = V_{EE2} + 2\text{ V}$	0.7	1.5		A
		UCC5350MC, $V_{CLAMP} = V_{EE2} + 2\text{ V}$	5	10		
$V_{CLAMP-TH}$	Clamp threshold voltage	UCC5310MC and UCC5350MC		2.1	2.3	V
SHORT CIRCUIT CLAMPING						
$V_{CLP-OUT}$	Clamping voltage ($V_{OUTH} - V_{CC2}$ or $V_{OUT} - V_{CC2}$)	IN+ = high, IN- = low, $t_{CLAMP} = 10\text{ }\mu\text{s}$, I_{OUTH} or $I_{OUT} = 500\text{ mA}$		1	1.3	V
$V_{CLP-OUT}$	Clamping voltage ($V_{EE2} - V_{OUTL}$ or $V_{EE2} - V_{CLAMP}$ or $V_{EE2} - V_{OUT}$)	IN+ = low, IN- = high, $t_{CLAMP} = 10\text{ }\mu\text{s}$, I_{CLAMP} or $I_{OUTL} = -500\text{ mA}$		1.5		V
		IN+ = low, IN- = high, I_{CLAMP} or $I_{OUTL} = -20\text{ mA}$		0.9	1	
ACTIVE PULLDOWN						
V_{OUTSD}	Active pulldown voltage on OUTL, CLAMP, OUT	I_{OUTL} or $I_{OUT} = 0.1 \times I_{OUTL(typ)}$, $V_{CC2} =$ open		1.8	2.5	V

8.12 Switching Characteristics

$V_{CC1} = 3.3\text{ V}$ or 5 V , $0.1\text{-}\mu\text{F}$ capacitor from V_{CC1} to GND1, $V_{CC2} = 15\text{ V}$, $1\text{-}\mu\text{F}$ capacitor from V_{CC2} to V_{EE2} , $T_A = -40^\circ\text{C}$ to $+125^\circ\text{C}$, (unless otherwise noted)

PARAMETER		TEST CONDITIONS	MIN	TYP	MAX	UNIT
t_r	Output-signal rise time	UCC5320SC, UCC5320EC, and UCC5310MC, $C_{LOAD} = 1\text{ nF}$		12	28	ns
		UCC5390SC, UCC5350SB, UCC5390EC, and UCC5350MC, $C_{LOAD} = 1\text{ nF}$		10	26	ns
t_f	Output-signal fall time	UCC5320SC and UCC5320EC, $C_{LOAD} = 1\text{ nF}$		10	25	ns
		UCC5310MC, $C_{LOAD} = 1\text{ nF}$		10	26	ns
		UCC5390SC, UCC5350SB, UCC5390EC, and UCC5350MC, $C_{LOAD} = 1\text{ nF}$		10	22	ns
t_{PLH}	Propagation delay (default versions), high	UCC5320SC and UCC5320EC, $C_{LOAD} = 100\text{ pF}$		60	72	ns
		UCC5310MC, $C_{LOAD} = 100\text{ pF}$		60	75	ns
		UCC5390SC, UCC5350SB, UCC5390EC, and UCC5350MC, $C_{LOAD} = 100\text{ pF}$		65	100	ns
t_{PHL}	Propagation delay (default versions), low	UCC5320CS and UCC5320EC, $C_{LOAD} = 100\text{ pF}$		60	75	ns
		UCC5310MC, $C_{LOAD} = 100\text{ pF}$		60	75	ns
		UCC5390SC, UCC5350SB, UCC5390EC, and UCC5350MC, $C_{LOAD} = 100\text{ pF}$		65	100	ns
t_{UVLO1_rec}	UVLO recovery delay of V_{CC1}	See 图 55		30		μs
t_{UVLO2_rec}	UVLO recovery delay of V_{CC2}	See 图 55		50		μs
t_{PWD}	Pulse width distortion $ t_{PHL} - t_{PLH} $	UCC5320SC and UCC5320EC, $C_{LOAD} = 100\text{ pF}$		1	20	ns
		UCC5310MC, $C_{LOAD} = 100\text{ pF}$		1	20	ns
		UCC5390SC, UCC5350SB, and UCC5390EC, $C_{LOAD} = 100\text{ pF}$		1	20	ns
		UCC5350MC, $C_{LOAD} = 100\text{ pF}$		1	20	ns
$t_{sk(pp)}$	Part-to-part skew ⁽¹⁾	UCC5320SC and UCC5320EC, $C_{LOAD} = 100\text{ pF}$		1	25	ns
		UCC5310MC, $C_{LOAD} = 100\text{ pF}$		1	25	ns
		UCC5390SC, UCC5350SB, and UCC5390EC, $C_{LOAD} = 100\text{ pF}$		1	25	ns
		UCC5350MC, $C_{LOAD} = 100\text{ pF}$		1	25	ns
CMTI	Common-mode transient immunity	PWM is tied to GND or V_{CC1} , $V_{CM} = 1200\text{ V}$	100	120		kV/ μs

(1) $t_{sk(pp)}$ is the magnitude of the difference in propagation delay times between the output of different devices switching in the same direction while operating at identical supply voltages, temperature, input signals and loads guaranteed by characterization.

8.13 Insulation Characteristics Curves



图 1. Thermal Derating Curve for Limiting Current per VDE for D Package



图 2. Thermal Derating Curve for Limiting Current per VDE for DWV Package

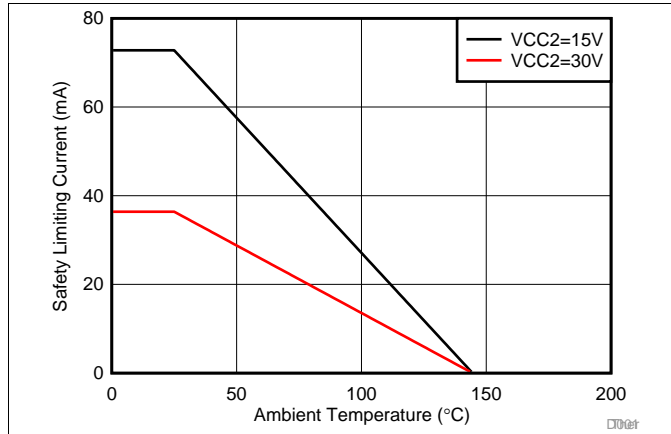

图 3. Thermal Derating Curve for Limiting Power per VDE for D Package

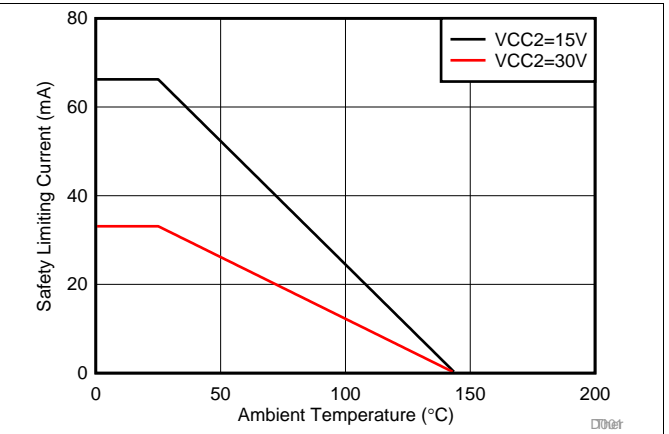

图 4. Thermal Derating Curve for Limiting Power per VDE for DWV Package

8.14 Typical Characteristics

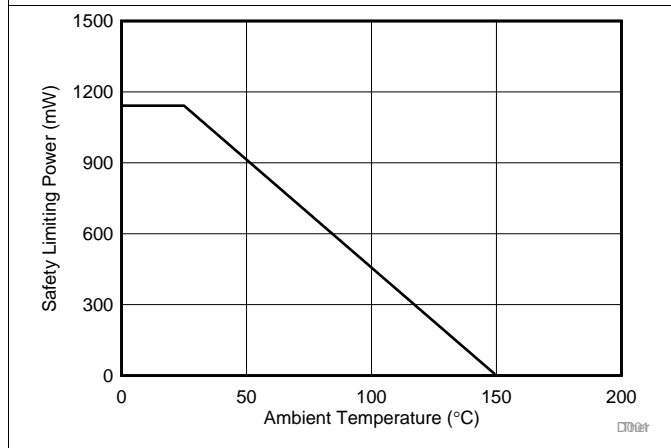
$V_{CC1} = 3.3\text{ V}$ or 5 V , $0.1\text{-}\mu\text{F}$ capacitor from V_{CC1} to GND1 , $V_{CC2} = 15\text{ V}$, $1\text{-}\mu\text{F}$ capacitor from V_{CC2} to V_{EE2} , $C_{LOAD} = 1\text{ nF}$, $T_A = -40^\circ\text{C}$ to $+125^\circ\text{C}$, (unless otherwise noted)

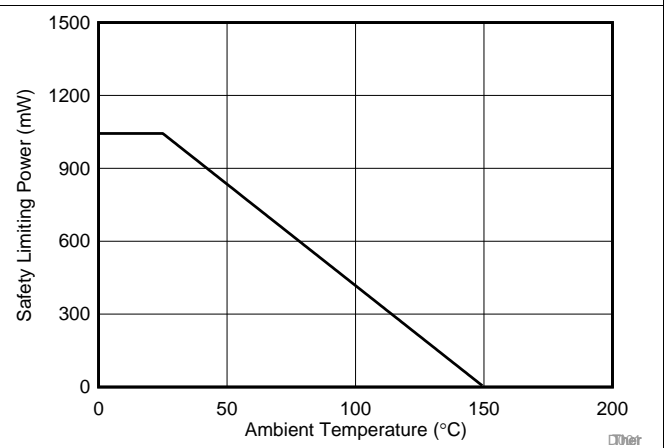

图 5. Output-High Drive Current vs Output Voltage



图 6. Output-High Drive Current vs Output Voltage

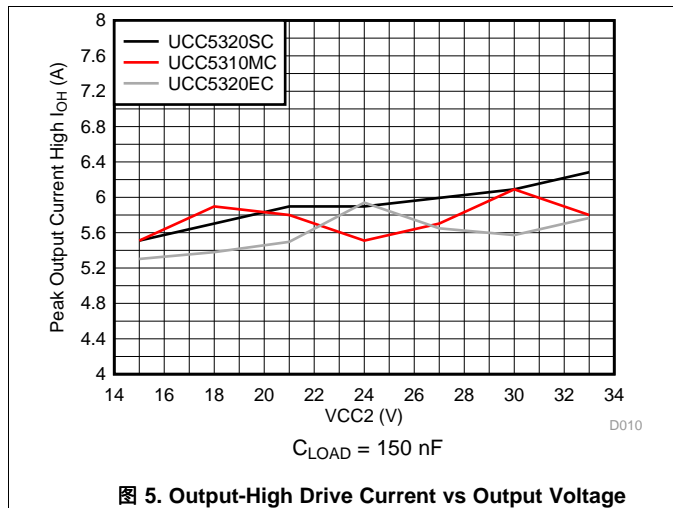

图 7. UCC5350SBD Output-High Drive Current vs Output Voltage

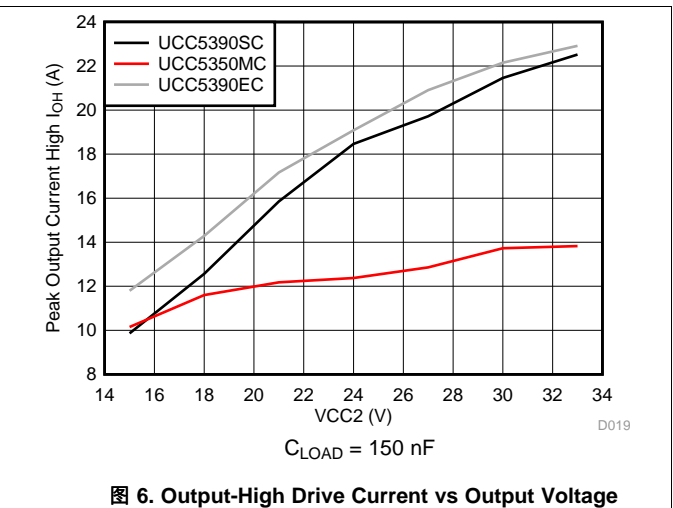

图 8. Output-Low Drive Current vs Output Voltage

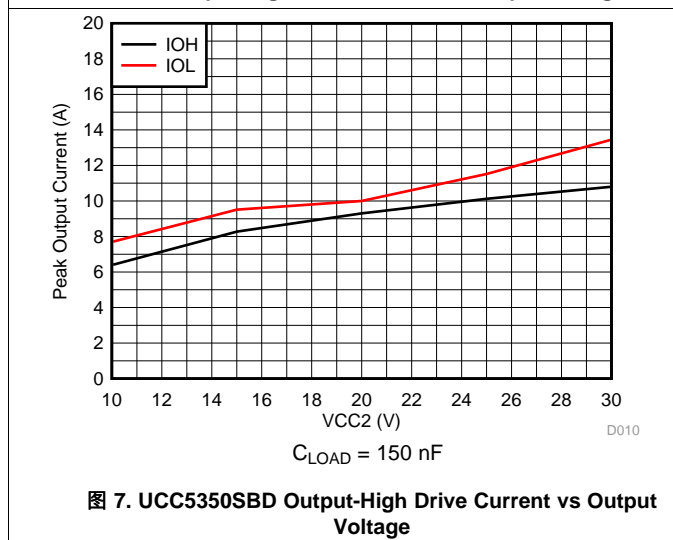

图 9. Output-Low Drive Current vs Output Voltage

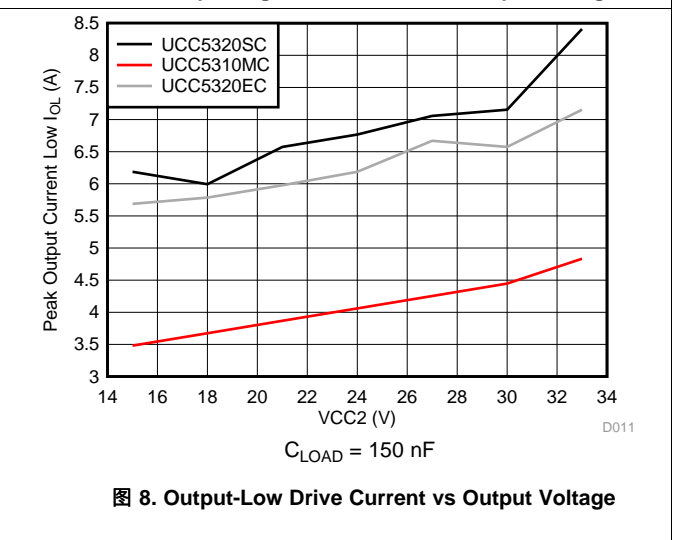

图 10. I_{CC1} Supply Current vs Temperature

Typical Characteristics (接下页)

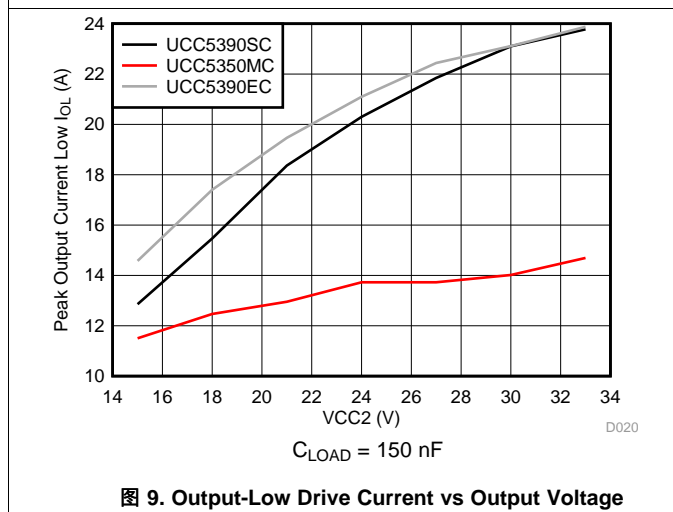
$V_{CC1} = 3.3\text{ V}$ or 5 V , $0.1\text{-}\mu\text{F}$ capacitor from V_{CC1} to $GND1$, $V_{CC2} = 15\text{ V}$, $1\text{-}\mu\text{F}$ capacitor from V_{CC2} to V_{EE2} , $C_{LOAD} = 1\text{ nF}$, $T_A = -40^\circ\text{C}$ to $+125^\circ\text{C}$, (unless otherwise noted)

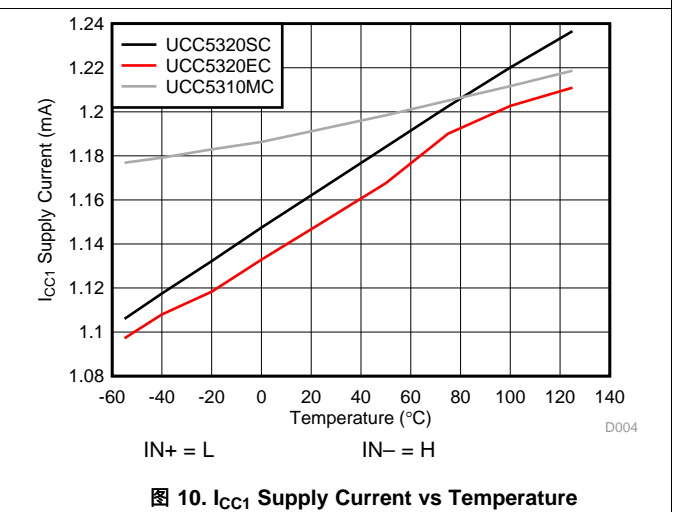

图 11. I_{CC1} Supply Current vs Temperature



图 12. I_{CC1} Supply Current vs Temperature

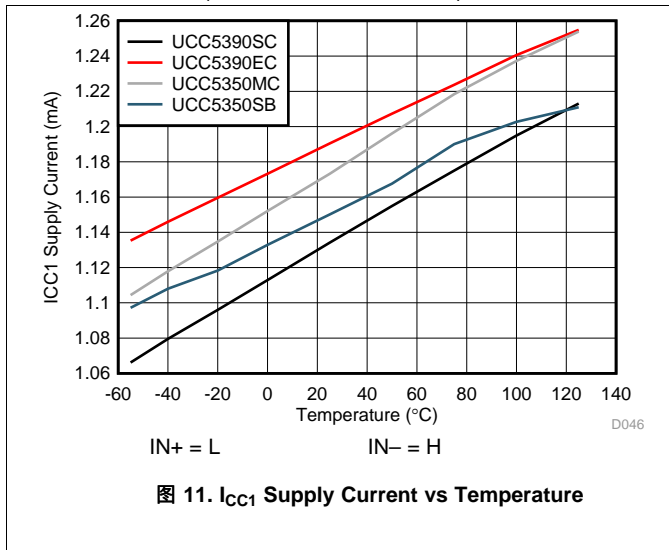

图 13. I_{CC1} Supply Current vs Temperature

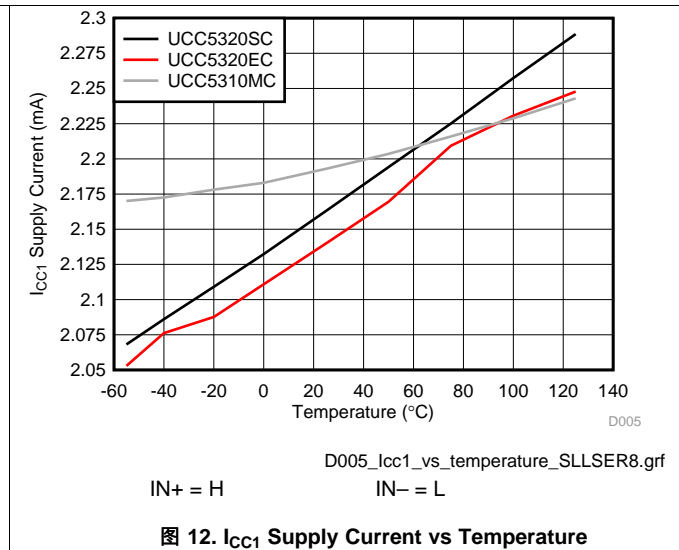

图 14. I_{CC1} Supply Current vs Input Frequency

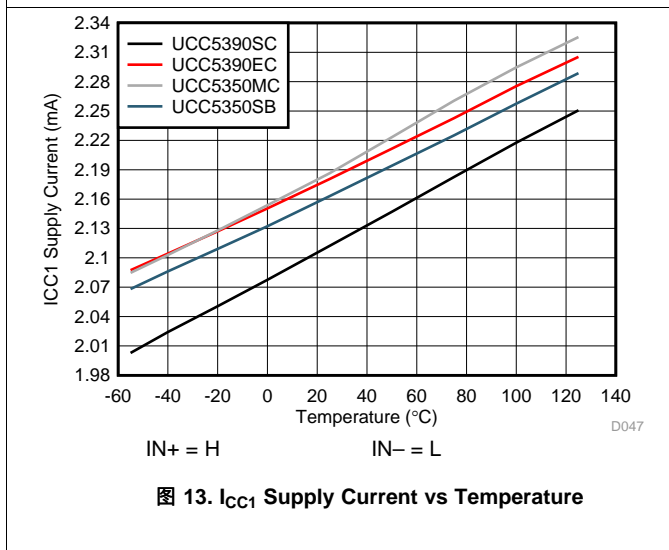

图 15. I_{CC1} Supply Current vs Input Frequency

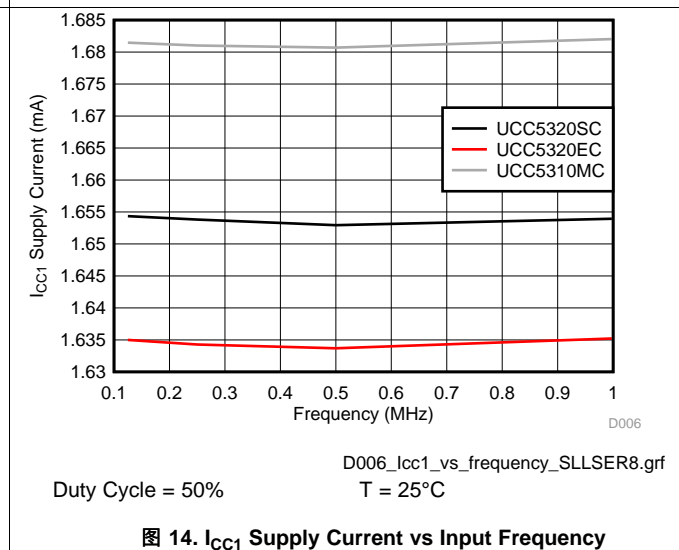

图 16. I_{CC2} Supply Current vs Temperature

Typical Characteristics (接下页)

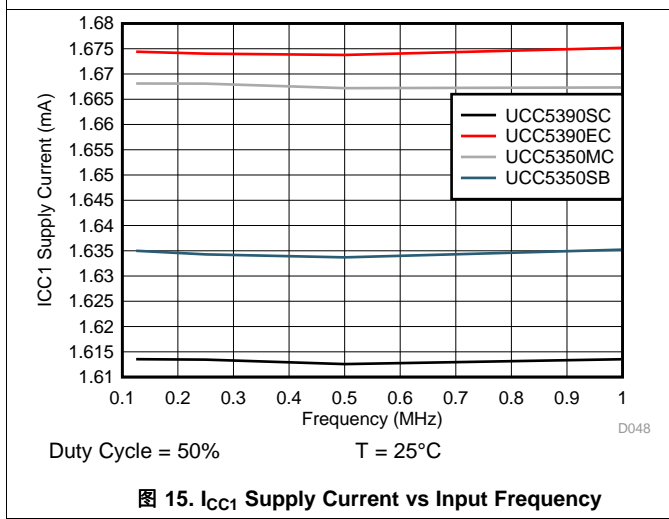
$V_{CC1} = 3.3\text{ V}$ or 5 V , $0.1\text{-}\mu\text{F}$ capacitor from V_{CC1} to GND1 , $V_{CC2} = 15\text{ V}$, $1\text{-}\mu\text{F}$ capacitor from V_{CC2} to V_{EE2} , $C_{LOAD} = 1\text{ nF}$, $T_A = -40^\circ\text{C}$ to $+125^\circ\text{C}$, (unless otherwise noted)

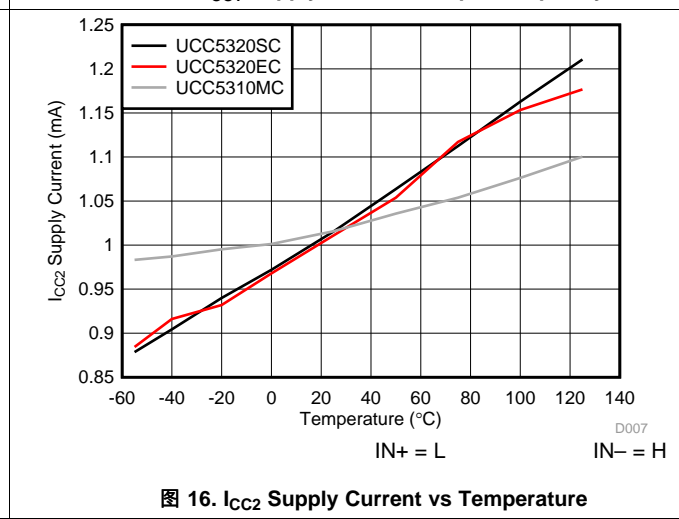

图 17. I_{CC2} Supply Current vs Temperature



图 18. I_{CC2} Supply Current vs Temperature

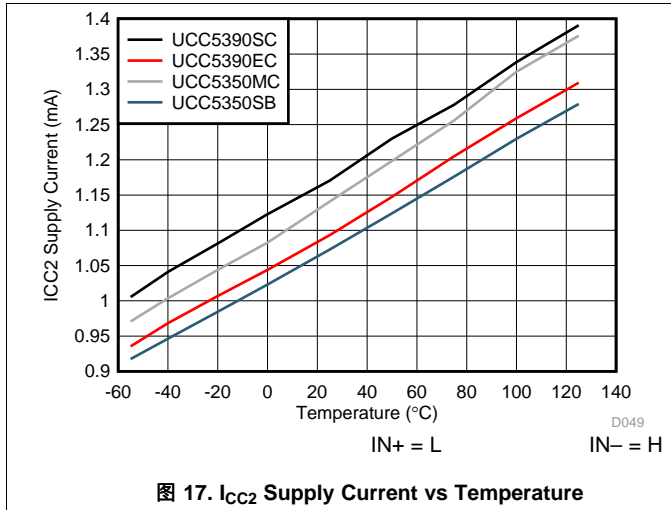

图 19. I_{CC2} Supply Current vs Temperature

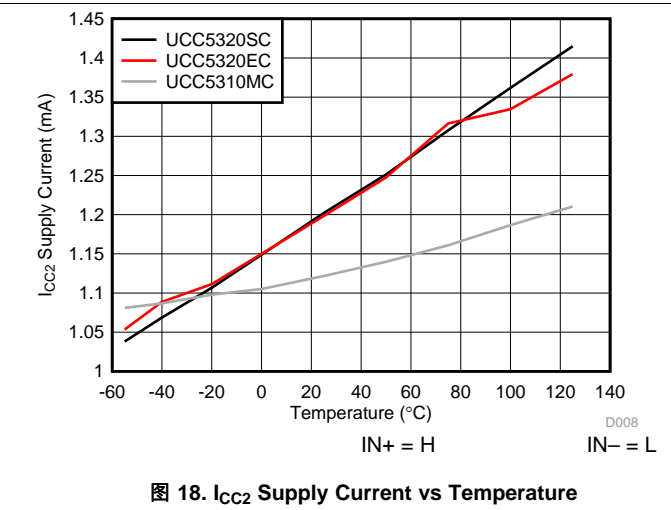

图 20. I_{CC2} Supply Current vs Input Frequency

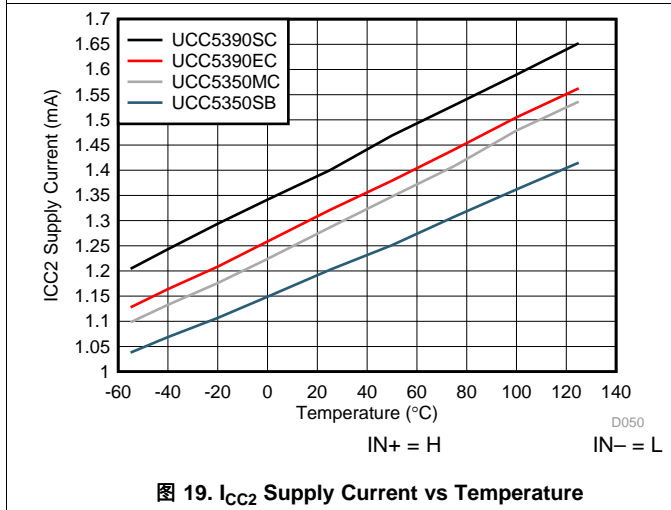

图 21. I_{CC2} Supply Current vs Input Frequency

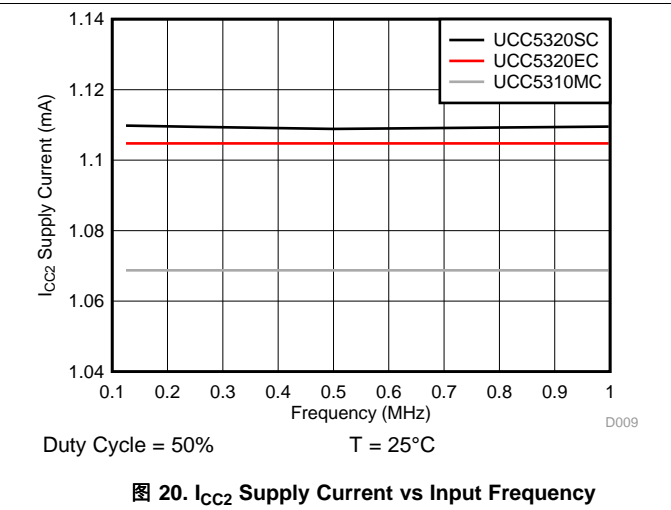

图 22. I_{CC2} Supply Current vs Load Capacitance

Typical Characteristics (接下页)

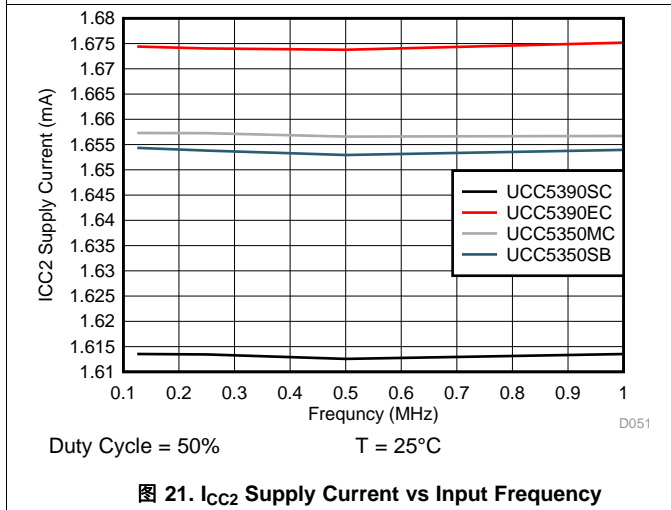
$V_{CC1} = 3.3\text{ V}$ or 5 V , $0.1\text{-}\mu\text{F}$ capacitor from V_{CC1} to GND1 , $V_{CC2} = 15\text{ V}$, $1\text{-}\mu\text{F}$ capacitor from V_{CC2} to V_{EE2} , $C_{LOAD} = 1\text{ nF}$, $T_A = -40^\circ\text{C}$ to $+125^\circ\text{C}$, (unless otherwise noted)

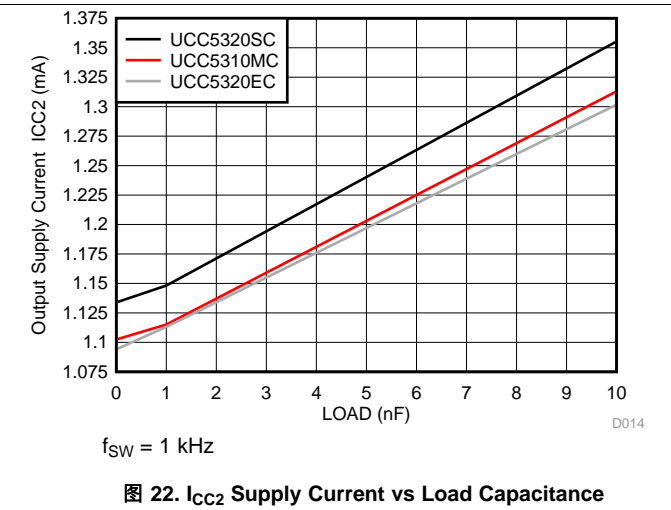

图 23. I_{CC2} Supply Current vs Load Capacitance



图 24. UCC5310M V_{Clamp} vs Temperature

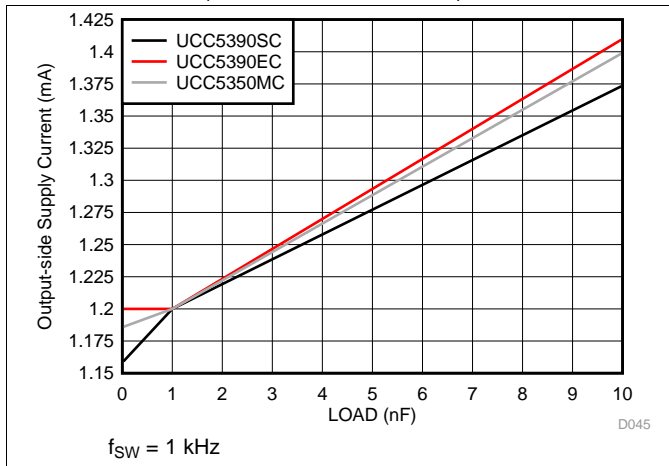

图 25. UCC5350M V_{Clamp} vs Temperature

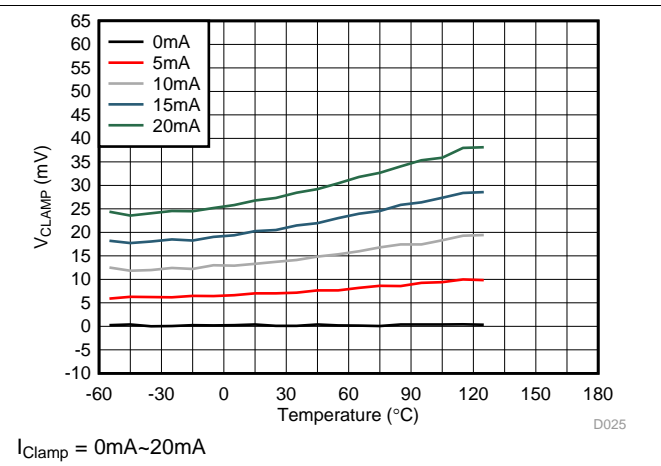

图 26. $V_{Clamp-TH}$ vs Temperature

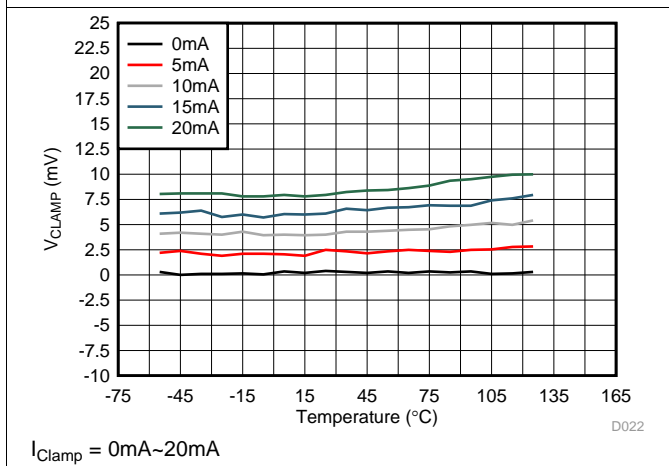

图 27. Rise Time vs Temperature

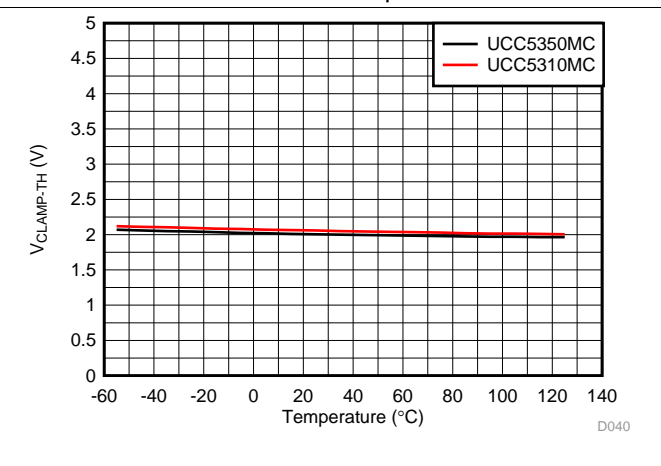

图 28. Rise Time vs Temperature

Typical Characteristics (接下页)

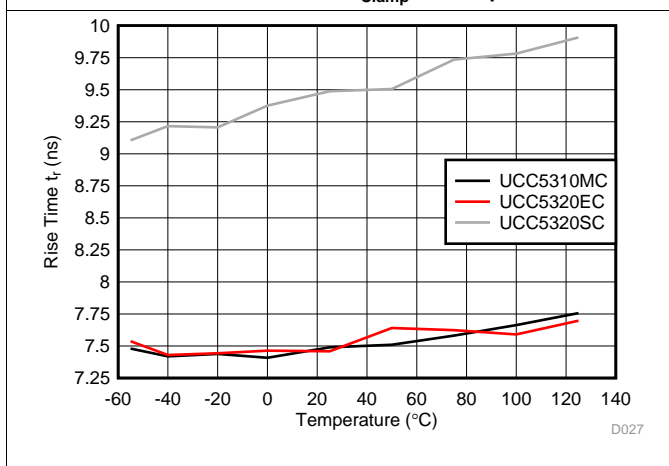
$V_{CC1} = 3.3\text{ V}$ or 5 V , $0.1\text{-}\mu\text{F}$ capacitor from V_{CC1} to $GND1$, $V_{CC2} = 15\text{ V}$, $1\text{-}\mu\text{F}$ capacitor from V_{CC2} to V_{EE2} , $C_{LOAD} = 1\text{ nF}$, $T_A = -40^\circ\text{C}$ to $+125^\circ\text{C}$, (unless otherwise noted)

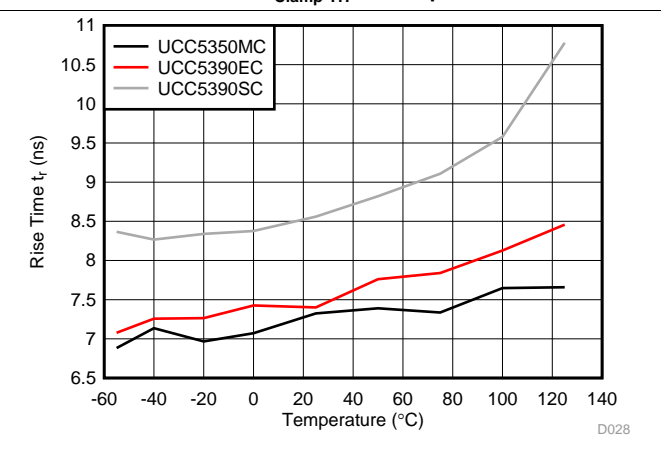

图 29. Fall Time Vs Temperature



图 30. Fall Time vs Temperature

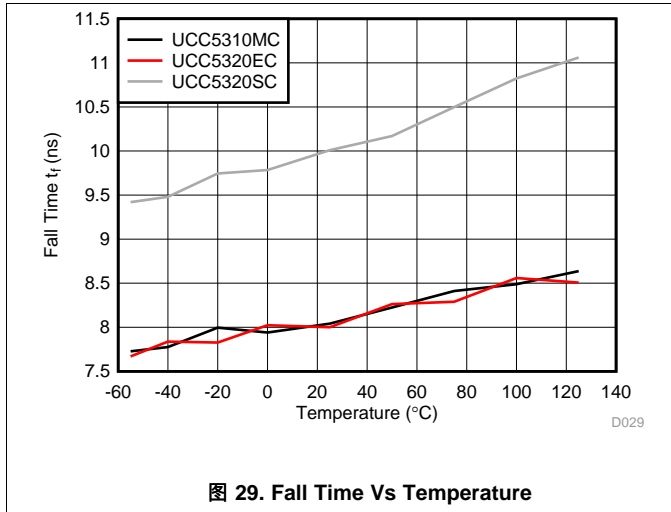

图 31. Propagation Delay t_{PLH} vs Temperature

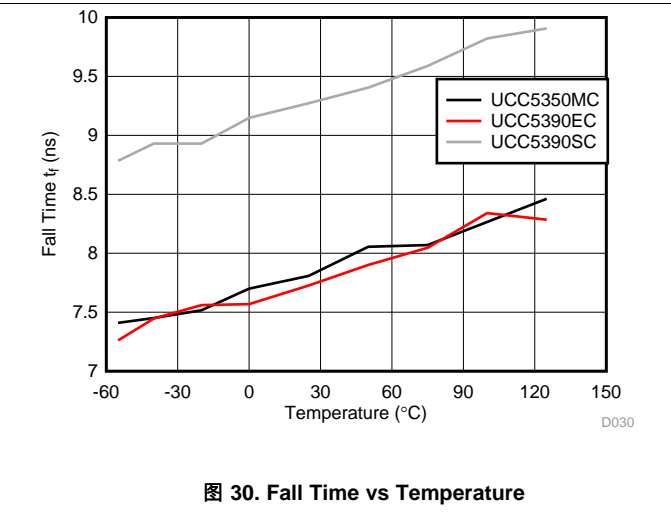

图 32. Propagation Delay t_{PLH} vs Temperature

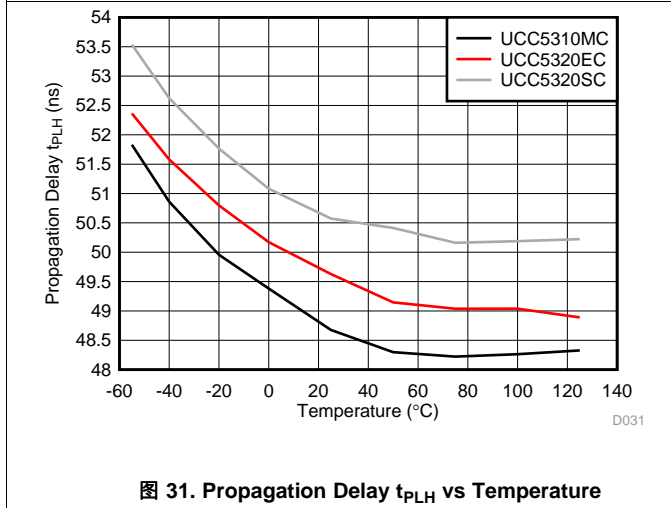

图 33. UCC5350SBD Propagation Delay vs Temperature

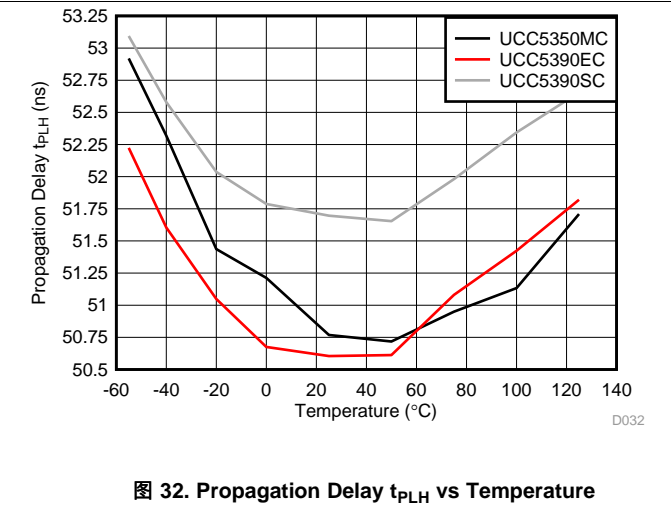

图 34. Propagation Delay t_{PHL} vs Temperature

Typical Characteristics (接下页)

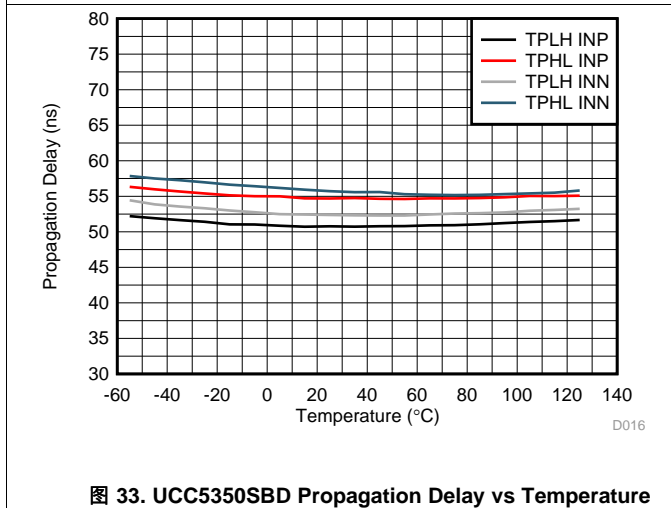
$V_{CC1} = 3.3\text{ V}$ or 5 V , $0.1\text{-}\mu\text{F}$ capacitor from V_{CC1} to $GND1$, $V_{CC2} = 15\text{ V}$, $1\text{-}\mu\text{F}$ capacitor from V_{CC2} to V_{EE2} , $C_{LOAD} = 1\text{ nF}$, $T_A = -40^\circ\text{C}$ to $+125^\circ\text{C}$, (unless otherwise noted)

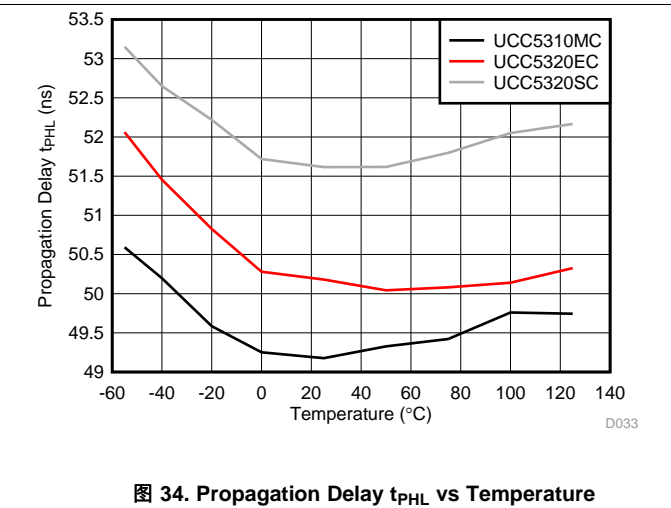

图 35. Propagation Delay t_{PHL} vs Temperature



图 36. Rise Time vs Load Capacitance

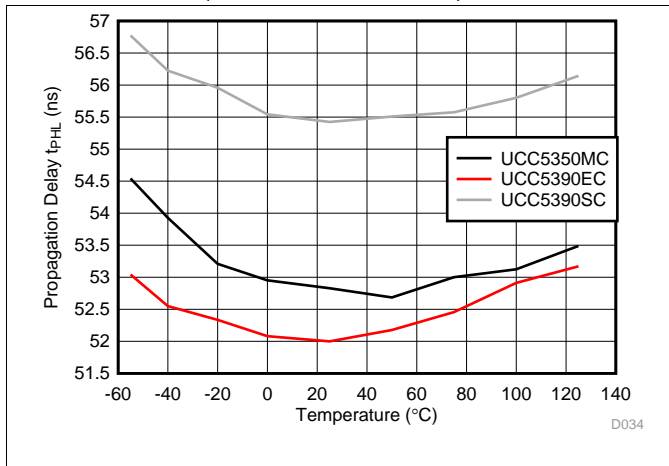

图 37. Rise Time vs Load Capacitance

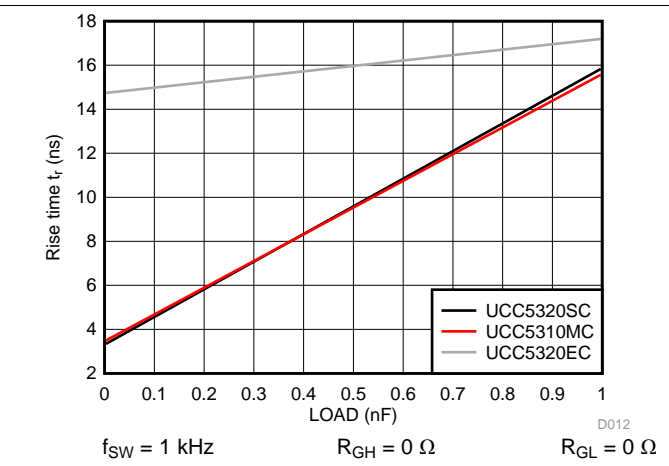

图 38. UCC5350SBD Rise Time vs C_L and V_{CC2}

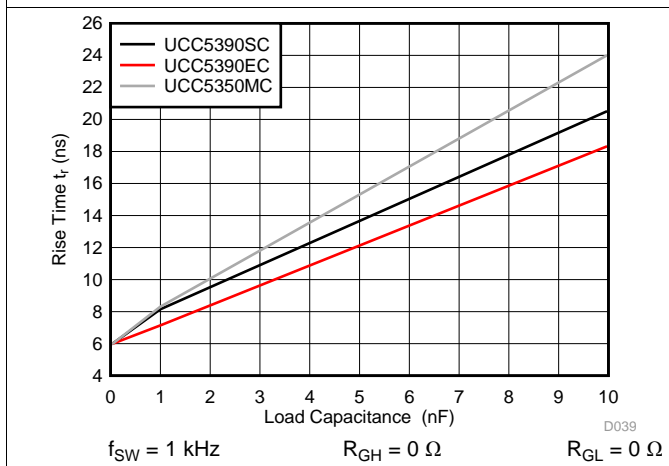

图 39. Fall Time vs Load Capacitance

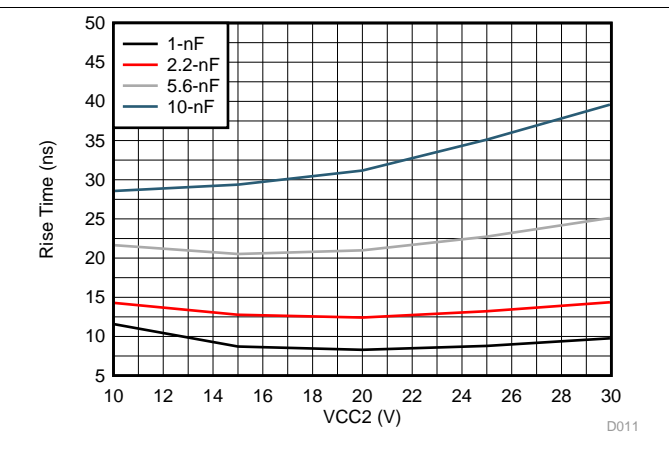

图 40. Fall Time vs Load Capacitance

Typical Characteristics (接下页)

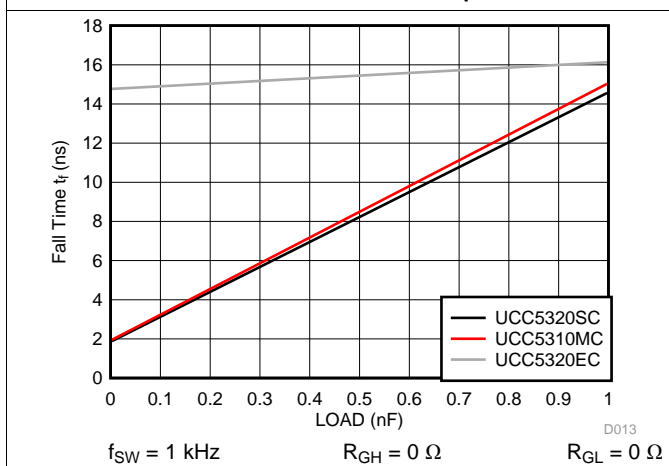
$V_{CC1} = 3.3\text{ V}$ or 5 V , $0.1\text{-}\mu\text{F}$ capacitor from V_{CC1} to GND1 , $V_{CC2} = 15\text{ V}$, $1\text{-}\mu\text{F}$ capacitor from V_{CC2} to V_{EE2} , $C_{\text{LOAD}} = 1\text{ nF}$, $T_A = -40^\circ\text{C}$ to $+125^\circ\text{C}$, (unless otherwise noted)

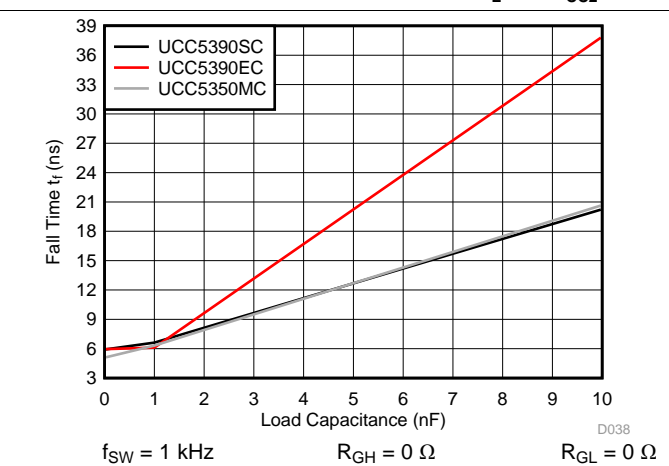

图 41. UCC5350SBD Fall Time vs C_L and V_{CC2}

9 Parameter Measurement Information

9.1 Propagation Delay, Inverting, and Noninverting Configuration

图 42 shows the propagation delay OUTH and OUTL for noninverting configurations. 图 43 shows the propagation delay with the inverting configuration. These figures also demonstrate the method used to measure the rise (t_r) and fall (t_f) times.

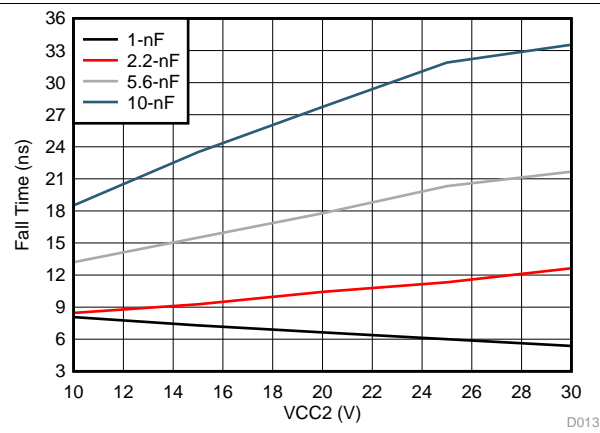

图 42. OUTH and OUTL Propagation Delay, Noninverting Configuration



图 43. OUTH and OUTL Propagation Delay, Inverting Configuration

Propagation Delay, Inverting, and Noninverting Configuration (接下页)

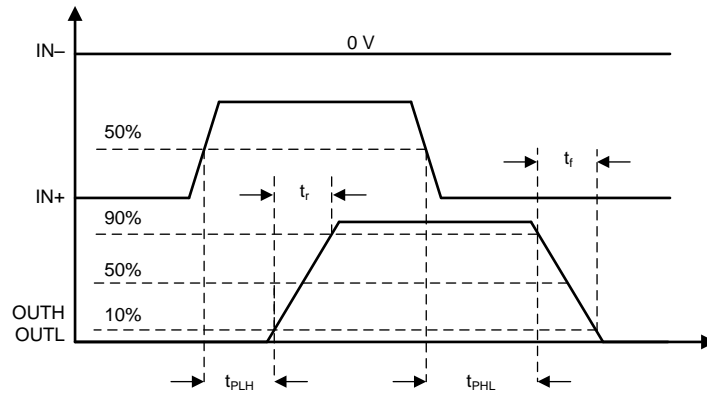
9.1.1 CMTI Testing

图 44, 图 45, and 图 46 are simplified diagrams of the CMTI testing configuration used for each device type.

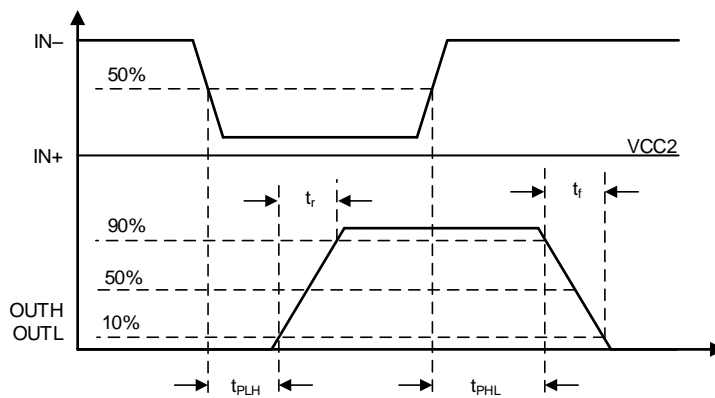
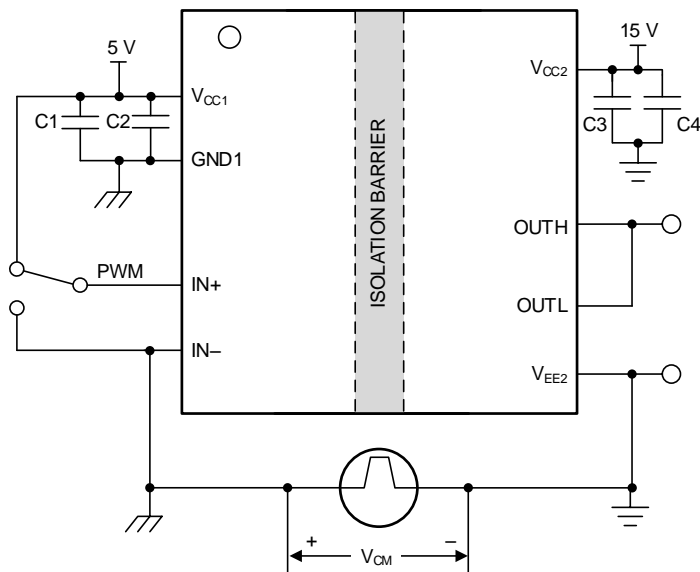

Copyright © 2017, Texas Instruments Incorporated

图 44. CMTI Test Circuit for Split Output (UCC53x0S)

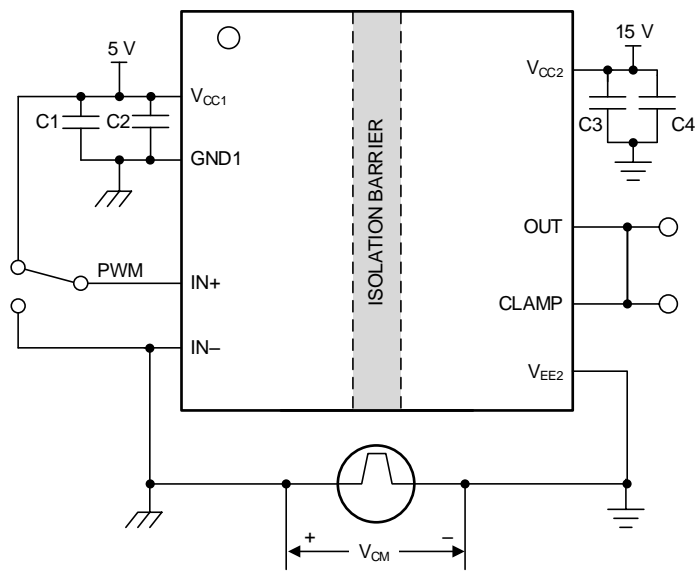

Copyright © 2017, Texas Instruments Incorporated

图 45. CMTI Test Circuit for Miller Clamp (UCC53x0M)

Propagation Delay, Inverting, and Noninverting Configuration (接下页)

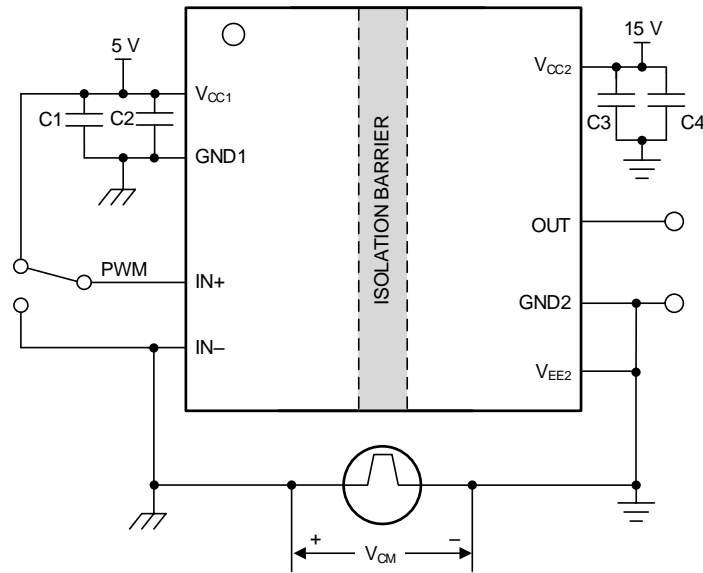

Copyright © 2017, Texas Instruments Incorporated

图 46. CMTI Test Circuit for UVLO2 with Respect to GND2 (UCC53x0E)

10 Detailed Description

10.1 Overview

The UCC53x0 family of isolated gate drivers has three variations: split output, Miller clamp, and UVLO2 referenced to GND2 (see [Device Comparison Table](#)). The isolation inside the UCC53x0 family of devices is implemented with high-voltage SiO₂-based capacitors. The signal across the isolation has an on-off keying (OOK) modulation scheme to transmit the digital data across a silicon dioxide based isolation barrier (see [Figure 48](#)). The transmitter sends a high-frequency carrier across the barrier to represent one digital state and sends no signal to represent the other digital state. The receiver demodulates the signal after advanced signal conditioning and produces the output through a buffer stage. The UCC53x0 devices also incorporate advanced circuit techniques to maximize the CMTI performance and minimize the radiated emissions from the high frequency carrier and IO buffer switching. The conceptual block diagram of a digital capacitive isolator, [Figure 47](#), shows a functional block diagram of a typical channel.

[Figure 47](#) shows how the input signal passes through the capacitive isolation barrier through modulation (OOK) and signal conditioning.

10.2 Functional Block Diagram

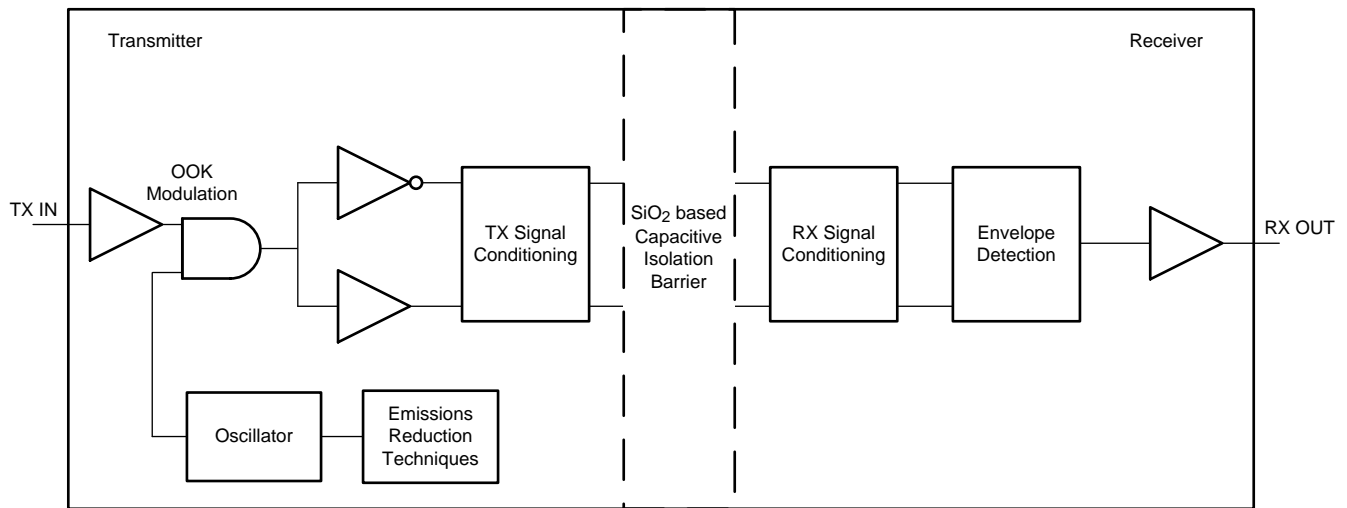

Copyright © 2017, Texas Instruments Incorporated

图 47. Conceptual Block Diagram of a Capacitive Data Channel



图 48. On-Off Keying (OOK) Based Modulation Scheme

Functional Block Diagram (接下页)



图 49. Functional Block Diagram — Split Output (UCC53x0S)

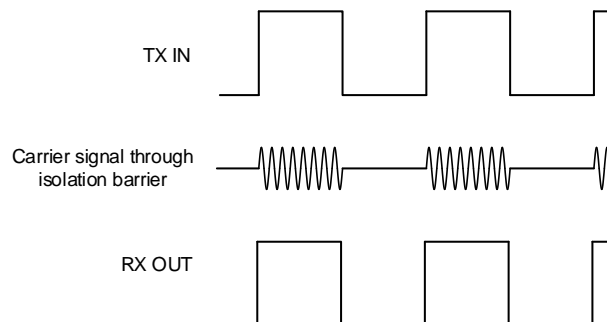

图 50. Functional Block Diagram — Miller Clamp (UCC53x0M)

Feature Description (接下页)

10.3.3 Output Stage

The output stages of the UCC53x0 family feature a pullup structure that delivers the highest peak-source current when it is most needed which is during the Miller plateau region of the power-switch turnon transition (when the power-switch drain or collector voltage experiences dV/dt). The output stage pullup structure features a P-channel MOSFET and an additional pullup N-channel MOSFET in parallel. The function of the N-channel MOSFET is to provide a brief boost in the peak-sourcing current, which enables fast turn-on. Fast turn-on is accomplished by briefly turning on the N-channel MOSFET during a narrow instant when the output is changing states from low to high. 表 1 lists the typical internal resistance values of the pullup and pulldown structure.

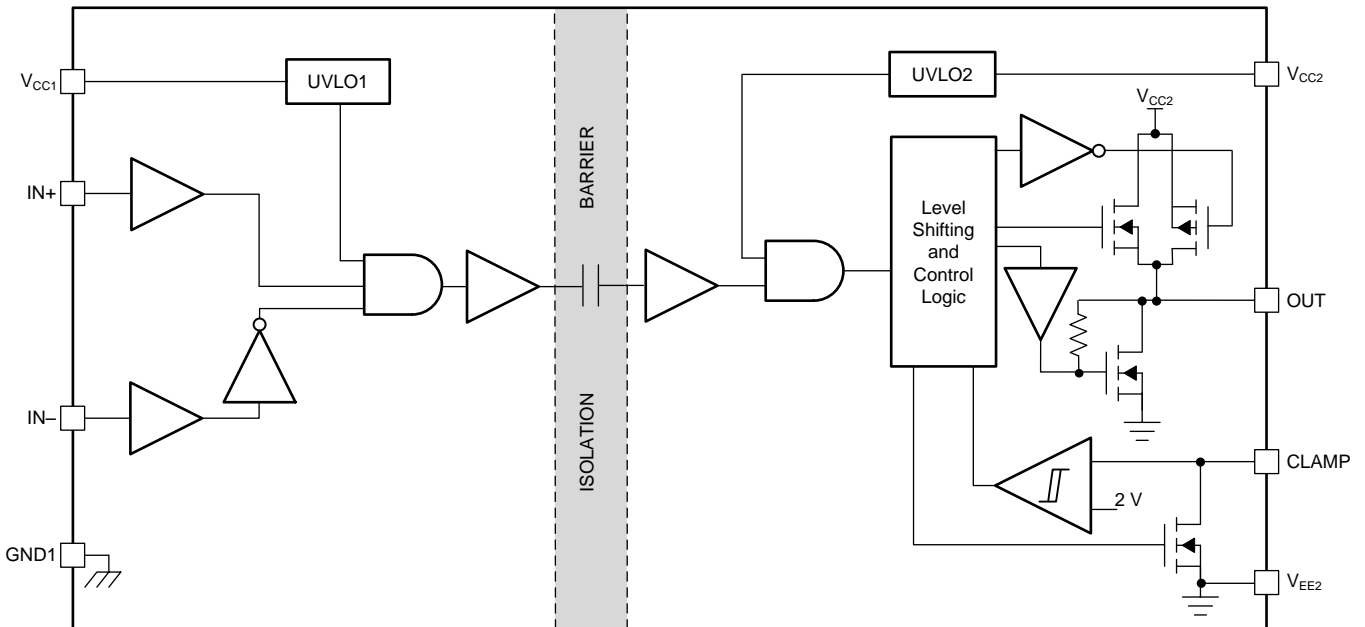
表 1. UCC53x0 On-Resistance

DEVICE OPTION	R_{NMOS}	R_{OH}	R_{OL}	R_{CLAMP}	UNIT
UCC5320SC and UCC5320EC	4.5	12	0.65	Not applicable	Ω
UCC5310MC	4.5	12	1.3	1.3	Ω
UCC5390SC and UCC5390EC	0.76	12	0.13	Not applicable	Ω
UCC5350MC	1.54	12	0.26	0.26	Ω
UCC5350SB	1.54	12	0.26	Not applicable	Ω

The R_{OH} parameter is a DC measurement and is representative of the on-resistance of the P-channel device only. This parameter is only for the P-channel device, because the pullup N-channel device is held in the OFF state in DC condition and is turned on only for a brief instant when the output is changing states from low to high. Therefore, the effective resistance of the UCC53x0 pullup stage during this brief turnon phase is much lower than what is represented by the R_{OH} parameter, which yields a faster turnon. The turnon-phase output resistance is the parallel combination $R_{OH} \parallel R_{NMOS}$.

The pulldown structure in the UCC53x0 S and E versions is simply composed of an N-channel MOSFET. For the M version, an additional FET is connected in parallel with the pulldown structure when the CLAMP and OUT pins are connected to the gate of the IGBT or MOSFET. The output voltage swing between V_{CC2} and V_{EE2} provides rail-to-rail operation.



图 52. Output Stage—S Version



图 53. Output Stage—E Version

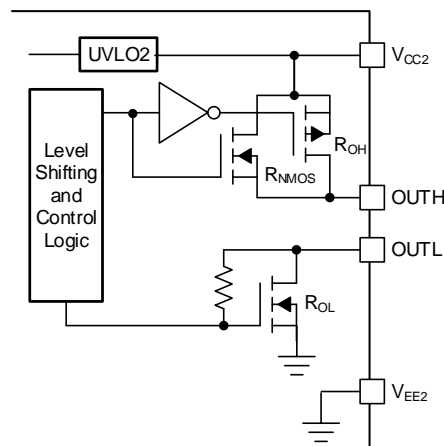

图 54. Output Stage—M Version

10.3.4 Protection Features

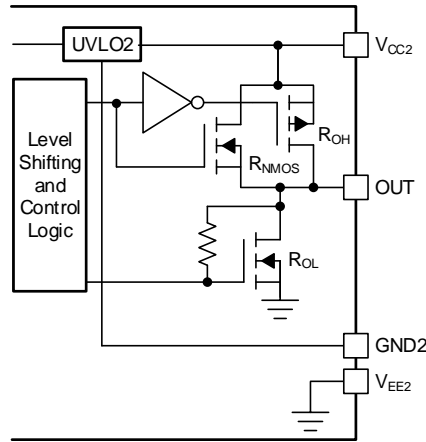
10.3.4.1 Undervoltage Lockout (UVLO)

UVLO functions are implemented for both the V_{CC1} and V_{CC2} supplies between the V_{CC1} and $GND1$, and V_{CC2} and V_{EE2} pins to prevent an underdriven condition on IGBTs and MOSFETs. When V_{CC} is lower than $V_{IT+ (UVLO)}$ at device start-up or lower than $V_{IT- (UVLO)}$ after start-up, the voltage-supply UVLO feature holds the effected output low, regardless of the input pins ($IN+$ and $IN-$) as shown in 表 4. The V_{CC} UVLO protection has a hysteresis feature ($V_{hys (UVLO)}$). This hysteresis prevents chatter when the power supply produces ground noise; this allows the device to permit small drops in bias voltage, which occurs when the device starts switching and operating current consumption increases suddenly. 图 55 shows the UVLO functions.

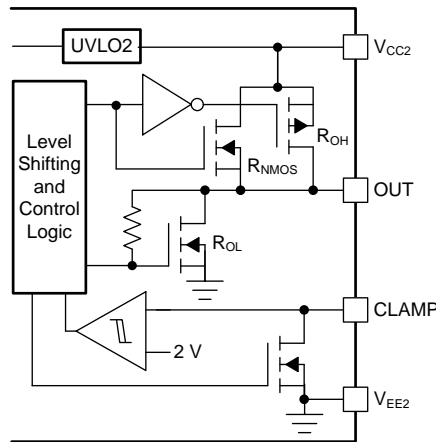
表 2. UCC53x0 V_{CC1} UVLO Logic

CONDITION	INPUTS		OUTPUTS	
	IN+	IN-	OUTH	OUT, OUTL
$V_{CC1} - GND1 < V_{IT+ (UVLO1)}$ during device start-up	H	L	Hi-Z	L
	L	H	Hi-Z	L
	H	H	Hi-Z	L
	L	L	Hi-Z	L

表 2. UCC53x0 V_{CC1} UVLO Logic (接下页)

CONDITION	INPUTS		OUTPUTS	
	IN+	IN–	OUTH	OUT, OUTL
$V_{CC1} - GND1 < V_{IT-(UVLO1)}$ after device start-up	H	L	Hi-Z	L
	L	H	Hi-Z	L
	H	H	Hi-Z	L
	L	L	Hi-Z	L

表 3. UCC53x0 V_{CC2} UVLO Logic

CONDITION	INPUTS		OUTPUTS	
	IN+	IN–	OUTH	OUT, OUTL
$V_{CC2} - V_{EE2} < V_{IT+(UVLO2)}$ during device start-up	H	L	Hi-Z	L
	L	H	Hi-Z	L
	H	H	Hi-Z	L
	L	L	Hi-Z	L
$V_{CC2} - V_{EE2} < V_{IT-(UVLO2)}$ after device start-up	H	L	Hi-Z	L
	L	H	Hi-Z	L
	H	H	Hi-Z	L
	L	L	Hi-Z	L

When V_{CC1} or V_{CC2} drops below the UVLO1 or UVLO2 threshold, a delay, t_{UVLO1_rec} or t_{UVLO2_rec} , occurs on the output when the supply voltage rises above $V_{IT+(UVLO)}$ or $V_{IT+(UVLO2)}$ again. 图 55 shows this delay.

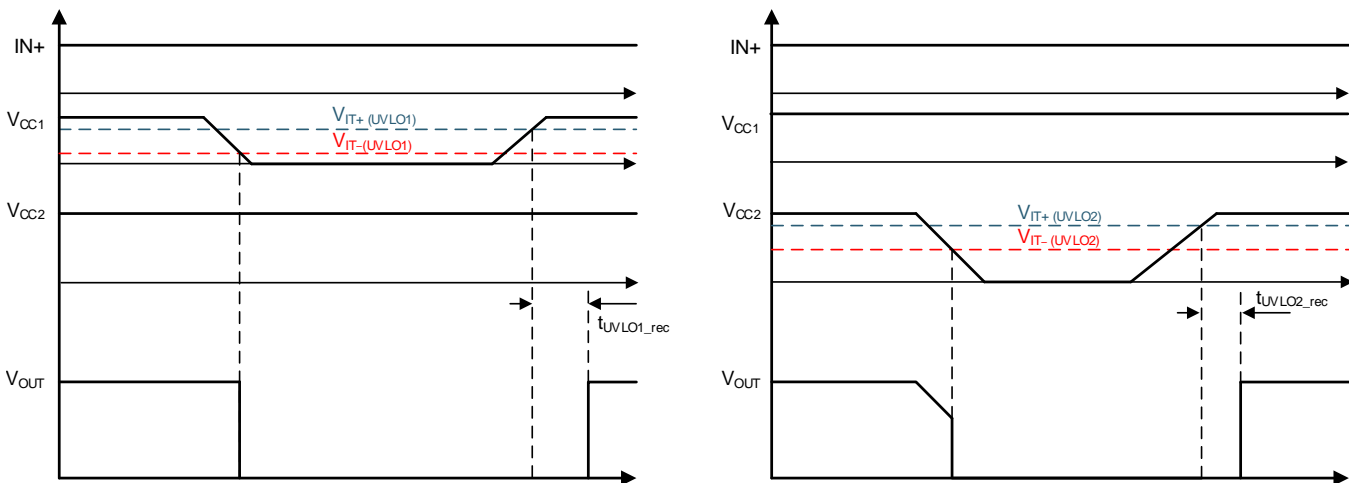
图 55. UVLO Functions

10.3.4.2 Active Pulldown

The active pulldown function is used to pull the IGBT or MOSFET gate to the low state when no power is connected to the V_{CC2} supply. This feature prevents false IGBT and MOSFET turnon on the OUT, OUTL, and CLAMP pins by clamping the output to approximately 2 V.

When the output stages of the driver are in an unbiased or UVLO condition, the driver outputs are held low by an active clamp circuit that limits the voltage rise on the driver outputs. In this condition, the upper PMOS is resistively held off by a pullup resistor while the lower NMOS gate is tied to the driver output through a 500-k Ω resistor. In this configuration, the output is effectively clamped to the threshold voltage of the lower NMOS device, which is approximately 1.5 V when no bias power is available.

10.3.4.3 Short-Circuit Clamping

The short-circuit clamping function is used to clamp voltages at the driver output and pull the active Miller clamp pins slightly higher than the V_{CC2} voltage during short-circuit conditions. The short-circuit clamping function helps protect the IGBT or MOSFET gate from overvoltage breakdown or degradation. The short-circuit clamping function is implemented by adding a diode connection between the dedicated pins and the V_{CC2} pin inside the driver. The internal diodes can conduct up to 500-mA current for a duration of 10 μ s and a continuous current of 20 mA. Use external Schottky diodes to improve current conduction capability as needed.

10.3.4.4 Active Miller Clamp (UCC53x0M)

The active Miller-clamp function is used to prevent false turn-on of the power switches caused by Miller current in applications where a unipolar power supply is used. The active Miller-clamp function is implemented by adding a low impedance path between the power-switch gate terminal and ground (V_{EE2}) to sink the Miller current. With the Miller-clamp function, the power-switch gate voltage is clamped to less than 2 V during the off state. [图 58](#) shows a typical application circuit of UCC5310M and UCC5350M.

10.4 Device Functional Modes

[表 4](#) lists the functional modes for the UCC53x0 devices assuming V_{CC1} and V_{CC2} are in the recommended range.

表 4. Function Table for UCC53x0S

IN+	IN–	OUTH	OUTL
Low	X	Hi-Z	Low
X	High	Hi-Z	Low
High	Low	High	High-Z

表 5. Function Table for UCC53x0M and UCC53x0E

IN+	IN–	OUT
Low	X	Low
X	High	Low
High	Low	High

10.4.1 ESD Structure

图 56 shows the multiple diodes involved in the ESD protection components of the UCC53x0 devices . This provides pictorial representation of the absolute maximum rating for the device.



图 56. ESD Structure

11 Application and Implementation

注

Information in the following applications sections is not part of the TI component specification, and TI does not warrant its accuracy or completeness. TI's customers are responsible for determining suitability of components for their purposes. Customers should validate and test their design implementation to confirm system functionality.

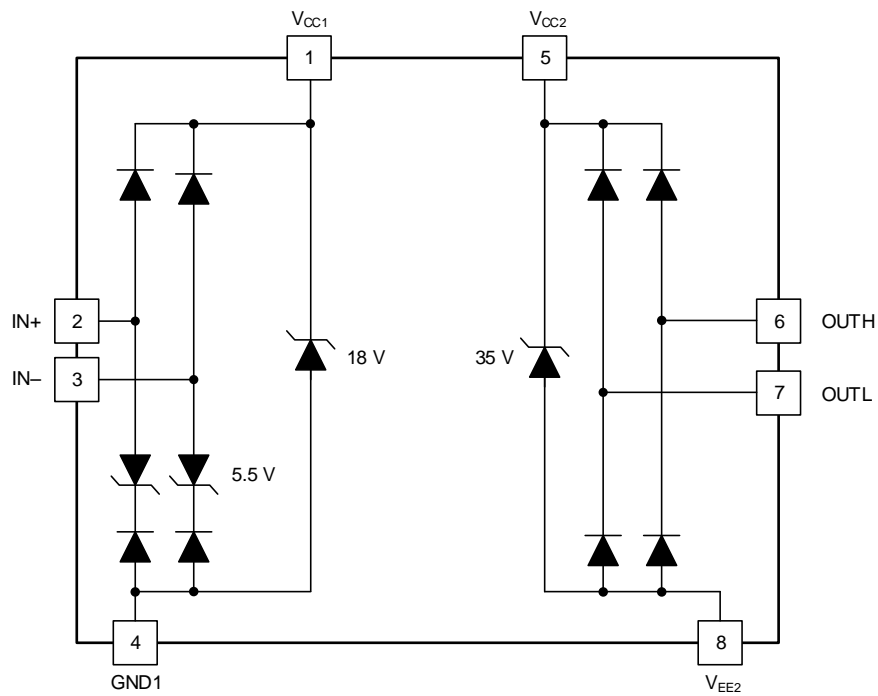
11.1 Application Information

The UCC53x0 is a family of simple, isolated gate drivers for power semiconductor devices, such as MOSFETs, IGBTs, or SiC MOSFETs. The family of devices is intended for use in applications such as motor control, solar inverters, switched-mode power supplies, and industrial inverters.

The UCC53x0 family of devices has three pinout configurations, featuring split outputs, Miller clamp, and UVLO with reference to GND2. The UCC5320SC, UCC5350SB, and UCC5390SC have a split output, OUTH and OUTL. The two pins can be used to separately decouple the power transistor turnon and turnoff commutations. The UCC5310MC and UCC5350MC feature active Miller clamping, which can be used to prevent false turn-on of the power transistors induced by the Miller current. The UCC5320EC and UCC5390EC offer true UVLO protection by monitoring the voltage between the V_{CC2} and GND2 pins to prevent the power transistors from operating in a saturation region. The UCC53x0 family of devices comes in an 8-pin D and 8-pin DWV package options and have a creepage, or clearance, of 4 mm and 8.5 mm respectively, which are suitable for applications where basic or reinforced isolation is required. Different drive strengths enable a simple driver platform to be used for applications demanding power transistors with different power ratings. Specifically, the UCC5390 device offers a 10-A minimum drive current which can help remove the external current buffer used to drive high power transistors.

11.2 Typical Application

The circuits in 图 57, 图 58, and 图 59 show a typical application for driving IGBTs.

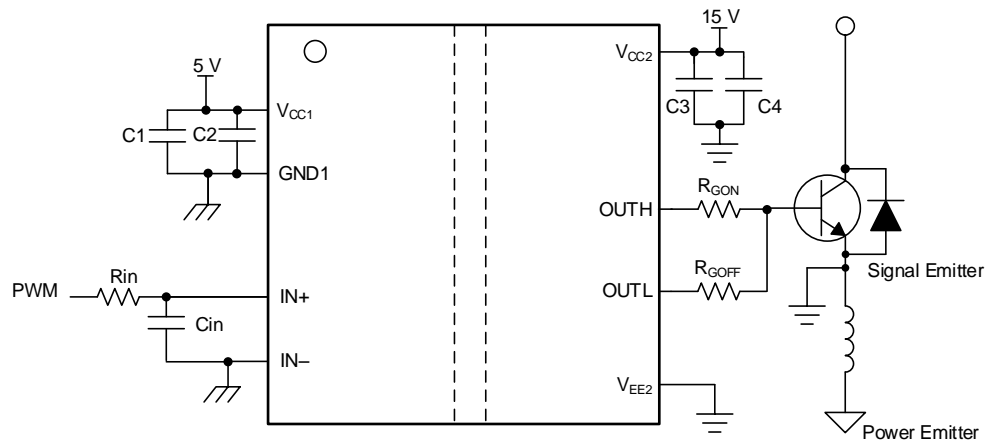

Copyright © 2017, Texas Instruments Incorporated

图 57. Typical Application Circuit for UCC53x0S to Drive IGBT

Typical Application (接下页)

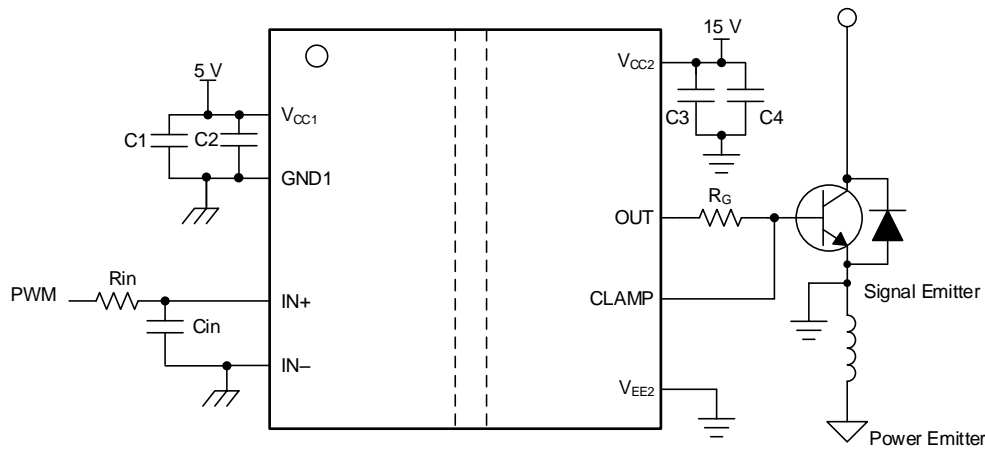

Copyright © 2017, Texas Instruments Incorporated

图 58. Typical Application Circuit for UCC5310M and UCC5350M to Drive IGBT

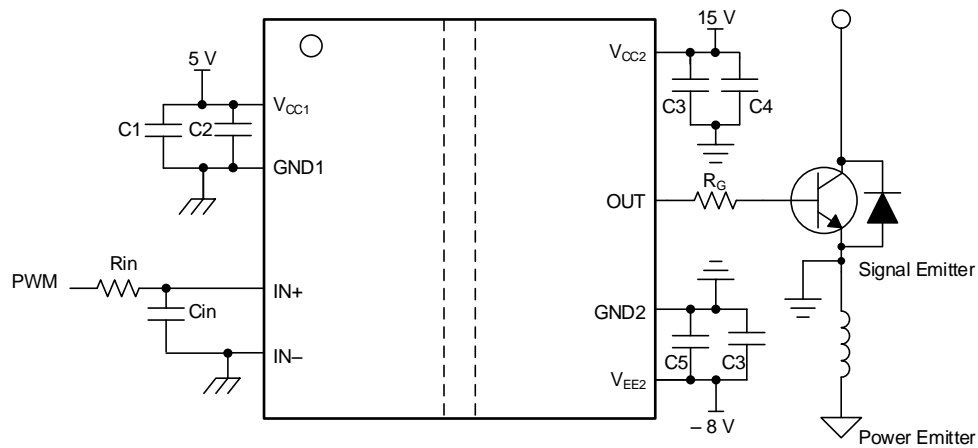

Copyright © 2018, Texas Instruments Incorporated

图 59. Typical Application Circuit for UCC5320E and UCC5390E to Drive IGBT

11.2.1 Design Requirements

表 6 lists the recommended conditions to observe the input and output of the UCC5320S split-output gate driver with the IN- pin tied to the GND1 pin.

表 6. UCC5320S Design Requirements

PARAMETER	VALUE	UNIT
V _{CC1}	3.3	V
V _{CC2}	15	V
IN+	3.3	V
IN-	GND1	-
Switching frequency	10	kHz
IGBT	IKW50N65H5	-

11.2.2 Detailed Design Procedure

11.2.2.1 Designing IN+ and IN– Input Filter

TI recommends that users avoid shaping the signals to the gate driver in an attempt to slow down (or delay) the signal at the output. However, a small input filter, R_{IN} - C_{IN} , can be used to filter out the ringing introduced by nonideal layout or long PCB traces.

Such a filter should use an R_{IN} resistor with a value from 0 Ω to 100 Ω and a C_{IN} capacitor with a value from 10 pF to 1000 pF. In the example, the selected value for R_{IN} is 51 Ω and C_{IN} is 33 pF, with a corner frequency of approximately 100 MHz.

When selecting these components, pay attention to the trade-off between good noise immunity and propagation delay.

11.2.2.2 Gate-Driver Output Resistor

The external gate-driver resistors, $R_{G(ON)}$ and $R_{G(OFF)}$ are used to:

1. Limit ringing caused by parasitic inductances and capacitances
2. Limit ringing caused by high voltage or high current switching dv/dt , di/dt , and body-diode reverse recovery
3. Fine-tune gate drive strength, specifically peak sink and source current to optimize the switching loss
4. Reduce electromagnetic interference (EMI)

The output stage has a pullup structure consisting of a P-channel MOSFET and an N-channel MOSFET in parallel. The combined peak source current is 4.3 A for the UCC5320 family and 17 A for the UCC5390 family. Use [公式 1](#) to estimate the peak source current using the UCC5320S as an example.

$$I_{OH} = \min \left(4.3 \text{ A}, \frac{V_{CC2}}{R_{NMOS} \parallel R_{OH} + R_{ON} + R_{GFET_Int}} \right)$$

where

- R_{ON} is the external turnon resistance.
- R_{GFET_Int} is the power transistor internal gate resistance, found in the power transistor data sheet. We will assume 0 Ω for our example
- I_{OH} is the peak source current which is the minimum value between 4.3 A, the gate-driver peak source current, and the calculated value based on the gate-drive loop resistance. (1)

In this example, the peak source current is approximately 1.8 A as calculated in [公式 2](#).

$$I_{OH} = \frac{V_{CC2}}{R_{NMOS} \parallel R_{OH} + R_{ON} + R_{GFET_Int}} = \frac{15 \text{ V}}{4.5 \Omega \parallel 12 \Omega + 5.1 \Omega + 0 \Omega} \approx 1.8 \text{ A} \quad (2)$$

Similarly, use [公式 3](#) to calculate the peak sink current.

$$I_{OL} = \min \left(4.4 \text{ A}, \frac{V_{CC2}}{R_{OL} + R_{OFF} + R_{GFET_Int}} \right)$$

where

- R_{OFF} is the external turnoff resistance.
- I_{OL} is the peak sink current which is the minimum value between 4.4 A, the gate-driver peak sink current, and the calculated value based on the gate-drive loop resistance. (3)

In this example, the peak sink current is the minimum of [公式 4](#) and 4.4 A.

$$I_{OL} = \frac{V_{CC2}}{R_{OL} + R_{OFF} + R_{GFET_Int}} = \frac{15 \text{ V}}{0.65 \Omega + 10 \Omega + 0 \Omega} \approx 1.4 \text{ A} \quad (4)$$

注

The estimated peak current is also influenced by PCB layout and load capacitance. Parasitic inductance in the gate-driver loop can slow down the peak gate-drive current and introduce overshoot and undershoot. Therefore, TI strongly recommends that the gate-driver loop should be minimized. Conversely, the peak source and sink current is dominated by loop parasitics when the load capacitance (C_{ISS}) of the power transistor is very small (typically less than 1 nF) because the rising and falling time is too small and close to the parasitic ringing period.

11.2.2.3 Estimate Gate-Driver Power Loss

The total loss, P_G , in the gate-driver subsystem includes the power losses (P_{GD}) of the UCC53x0 device and the power losses in the peripheral circuitry, such as the external gate-drive resistor.

The P_{GD} value is the key power loss which determines the thermal safety-related limits of the UCC53x0 device, and it can be estimated by calculating losses from several components.

The first component is the static power loss, P_{GDQ} , which includes quiescent power loss on the driver as well as driver self-power consumption when operating with a certain switching frequency. The P_{GDQ} parameter is measured on the bench with no load connected to the OUT or OUTH and OUTL pins at a given V_{CC1} , V_{CC2} , switching frequency, and ambient temperature. In this example, V_{CC1} is 3.3V and V_{CC2} is 15 V. The current on each power supply, with PWM switching from 0 V to 3.3 V at 10 kHz, is measured to be $I_{CC1} = 1.67$ mA and $I_{CC2} = 1.11$ mA. Therefore, use [公式 5](#) to calculate P_{GDQ} .

$$P_{GDQ} = V_{CC1} \times I_{VCC1} + V_{CC2} \times I_{CC2} \approx 22\text{mW} \quad (5)$$

The second component is the switching operation loss, P_{GDO} , with a given load capacitance which the driver charges and discharges the load during each switching cycle. Use [公式 6](#) to calculate the total dynamic loss from load switching, P_{GSW} .

$$P_{GSW} = V_{CC2} \times Q_G \times f_{SW}$$

where

- Q_G is the gate charge of the power transistor at V_{CC2} . (6)

So, for this example application the total dynamic loss from load switching is approximately 18 mW as calculated in [公式 7](#).

$$P_{GSW} = 15 \text{ V} \times 120 \text{ nC} \times 10 \text{ kHz} = 18 \text{ mW} \quad (7)$$

Q_G represents the total gate charge of the power transistor switching 520 V at 50 A, and is subject to change with different testing conditions. The UCC5320S gate-driver loss on the output stage, P_{GDO} , is part of P_{GSW} . P_{GDO} is equal to P_{GSW} if the external gate-driver resistance and power-transistor internal resistance are 0 Ω , and all the gate driver-loss will be dissipated inside the UCC5320S. If an external turn-on and turn-off resistance exists, the total loss is distributed between the gate driver pull-up/down resistance, external gate resistance, and power-transistor internal resistance. Importantly, the pull-up/down resistance is a linear and fixed resistance if the source/sink current is not saturated to 4.3 A/4.4 A, however, it will be non-linear if the source/sink current is saturated. Therefore, P_{GDO} is different in these two scenarios.

Case 1 - Linear Pull-Up/Down Resistor:

$$P_{GDO} = \frac{P_{GSW}}{2} \left(\frac{R_{OH} \parallel R_{NMOS}}{R_{OH} \parallel R_{NMOS} + R_{ON} + R_{GFET_Int}} + \frac{R_{OL}}{R_{OL} + R_{OFF} + R_{GFET_Int}} \right) \quad (8)$$

In this design example, all the predicted source and sink currents are less than 4.3 A and 4.4 A, therefore, use [公式 9](#) to estimate the UCC53x0 gate-driver loss.

$$P_{GDO} = \frac{18 \text{ mW}}{2} \left(\frac{12 \Omega \parallel 4.5 \Omega}{12 \Omega \parallel 4.5 \Omega + 5.1 \Omega + 0 \Omega} + \frac{0.65 \Omega}{0.65 \Omega + 10 \Omega + 0 \Omega} \right) \approx 4.1 \text{ mW} \quad (9)$$

Case 2 - Nonlinear Pull-Up/Down Resistor:

$$P_{GDO} = f_{SW} \times \left[4.3 \text{ A} \times \int_0^{T_{R_Sys}} (V_{CC2} - V_{OUTH}(t)) dt + 4.4 \text{ A} \times \int_0^{T_{F_Sys}} V_{OUTL}(t) dt \right]$$

where

- $V_{OUTH/L}(t)$ is the gate-driver OUTH and OUTL pin voltage during the turnon and turnoff period. In cases where the output is saturated for some time, this value can be simplified as a constant-current source (4.3 A at turnon and 4.4 A at turnoff) charging or discharging a load capacitor. Then, the $V_{OUTH/L}(t)$ waveform will be linear and the T_{R_Sys} and T_{F_Sys} can be easily predicted. (10)

For some scenarios, if only one of the pullup or pulldown circuits is saturated and another one is not, the P_{GDO} is a combination of case 1 and case 2, and the equations can be easily identified for the pullup and pulldown based on this discussion.

Use [公式 11](#) to calculate the total gate-driver loss dissipated in the UCC53x0 gate driver, P_{GD} .

$$P_{GD} = P_{GDQ} + P_{GDO} = 22\text{mW} + 4.1 \text{ mW} = 26.1 \text{ mW} \quad (11)$$

11.2.2.4 Estimating Junction Temperature

Use [公式 12](#) to estimate the junction temperature (T_J) of the UCC53x0 family.

$$T_J = T_C + \Psi_{JT} \times P_{GD}$$

where

- T_C is the UCC53x0 case-top temperature measured with a thermocouple or some other instrument.
- Ψ_{JT} is the junction-to-top characterization parameter from the [Thermal Information](#) table. (12)

Using the junction-to-top characterization parameter (Ψ_{JT}) instead of the junction-to-case thermal resistance ($R_{\theta JC}$) can greatly improve the accuracy of the junction temperature estimation. The majority of the thermal energy of most ICs is released into the PCB through the package leads, whereas only a small percentage of the total energy is released through the top of the case (where thermocouple measurements are usually conducted). The $R_{\theta JC}$ resistance can only be used effectively when most of the thermal energy is released through the case, such as with metal packages or when a heat sink is applied to an IC package. In all other cases, use of $R_{\theta JC}$ will inaccurately estimate the true junction temperature. The Ψ_{JT} parameter is experimentally derived by assuming that the dominant energy leaving through the top of the IC will be similar in both the testing environment and the application environment. As long as the recommended layout guidelines are observed, junction temperature estimations can be made accurately to within a few degrees Celsius.

11.2.3 Selecting V_{CC1} and V_{CC2} Capacitors

Bypass capacitors for the V_{CC1} and V_{CC2} supplies are essential for achieving reliable performance. TI recommends choosing low-ESR and low-ESL, surface-mount, multi-layer ceramic capacitors (MLCC) with sufficient voltage ratings, temperature coefficients, and capacitance tolerances.

注

DC bias on some MLCCs will impact the actual capacitance value. For example, a 25-V, 1- μF X7R capacitor is measured to be only 500 nF when a DC bias of 15- V_{DC} is applied.

11.2.3.1 Selecting a V_{CC1} Capacitor

A bypass capacitor connected to the V_{CC1} pin supports the transient current required for the primary logic and the total current consumption, which is only a few milliamperes. Therefore, a 50-V MLCC with over 100 nF is recommended for this application. If the bias power-supply output is located a relatively long distance from the V_{CC1} pin, a tantalum or electrolytic capacitor with a value greater than 1 μF should be placed in parallel with the MLCC.

11.2.3.2 Selecting a V_{CC2} Capacitor

A 50-V, 10- μF MLCC and a 50-V, 0.22- μF MLCC are selected for the C_{VCC2} capacitor. If the bias power supply output is located a relatively long distance from the V_{CC2} pin, a tantalum or electrolytic capacitor with a value greater than 10 μF should be used in parallel with C_{VCC2} .

11.2.3.3 Application Circuits With Output Stage Negative Bias

When parasitic inductances are introduced by nonideal PCB layout and long package leads (such as TO-220 and TO-247 type packages), ringing in the gate-source drive voltage of the power transistor could occur during high di/dt and dv/dt switching. If the ringing is over the threshold voltage, unintended turnon and shoot-through could occur. Applying a negative bias on the gate drive is a popular way to keep such ringing below the threshold. A few examples of implementing negative gate-drive bias follow.

图 60 shows the first example with negative bias turnoff on the output using a Zener diode on the isolated power-supply output stage. The negative bias is set by the Zener diode voltage. If the isolated power supply is equal to 20 V, the turnoff voltage is -5.1 V and the turnon voltage is $20\text{ V} - 5.1\text{ V} \approx 15\text{ V}$.

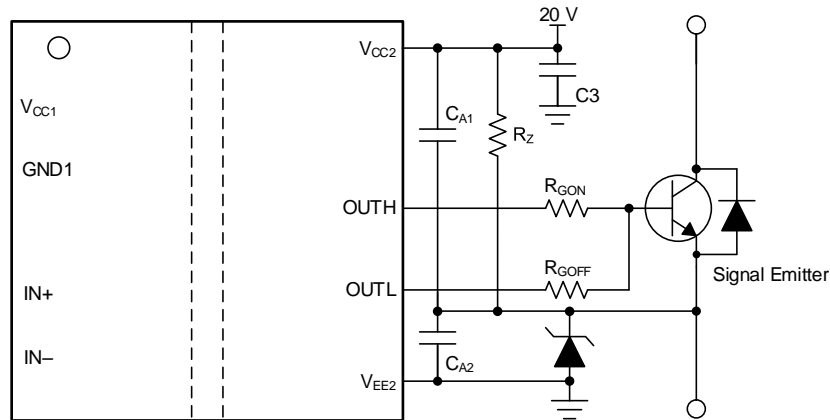

Copyright © 2017, Texas Instruments Incorporated

图 60. Negative Bias With Zener Diode on Iso-Bias Power-Supply Output

图 61 shows another example which uses two supplies (or single-input, double-output power supply). The power supply across V_{CC2} and GND2 determines the positive drive output voltage and the power supply across V_{EE2} and GND2 determines the negative turnoff voltage. This solution requires more power supplies than the first example, however, it provides more flexibility when setting the positive and negative rail voltages.

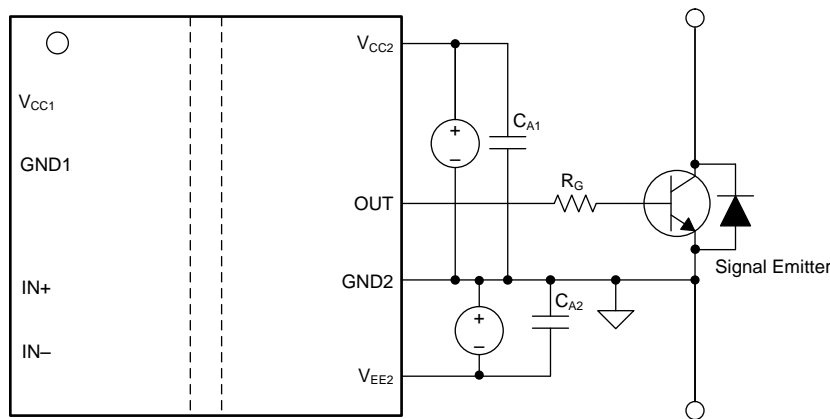

Copyright © 2017, Texas Instruments Incorporated

图 61. Negative Bias With Two Iso-Bias Power Supplies (UCC5320E and UCC5390E)

11.2.4 Application Curve

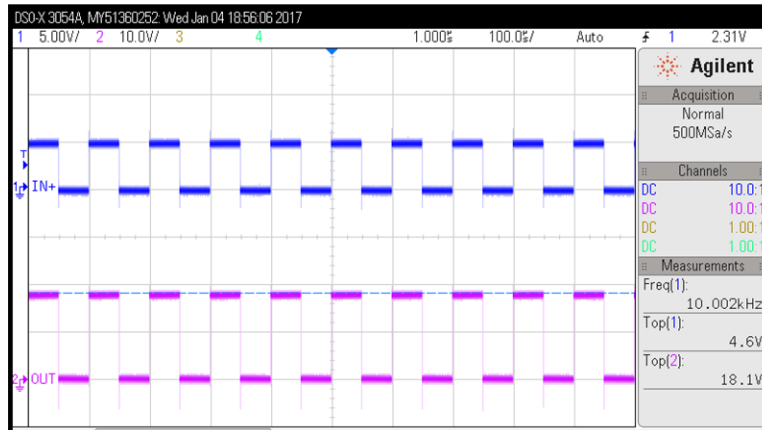

$$V_{CC2} = 20 \text{ V} \quad V_{EE2} = \text{GND} \quad f_{SW} = 10 \text{ kHz}$$

图 62. PWM Input And Gate Voltage Waveform

12 Power Supply Recommendations

The recommended input supply voltage (V_{CC1}) for the UCC53x0 device is from 3 V to 15 V. The lower limit of the range of output bias-supply voltage (V_{CC2}) is determined by the internal UVLO protection feature of the device. The V_{CC1} and V_{CC2} voltages should not fall below their respective UVLO thresholds for normal operation, or else the gate-driver outputs can become clamped low for more than 50 μs by the UVLO protection feature. For more information on UVLO, see the [Undervoltage Lockout \(UVLO\)](#) section. The higher limit of the V_{CC2} range depends on the maximum gate voltage of the power device that is driven by the UCC53x0 device, and should not exceed the recommended maximum V_{CC2} of 33 V. A local bypass capacitor should be placed between the V_{CC2} and V_{EE2} pins, with a value of 220-nF to 10- μF for device biasing. TI recommends placing an additional 100-nF capacitor in parallel with the device biasing capacitor for high frequency filtering. Both capacitors should be positioned as close to the device as possible. Low-ESR, ceramic surface-mount capacitors are recommended. Similarly, a bypass capacitor should also be placed between the V_{CC1} and GND1 pins. Given the small amount of current drawn by the logic circuitry within the input side of the UCC53x0 device, this bypass capacitor has a minimum recommended value of 100 nF.

If only a single, primary-side power supply is available in an application, isolated power can be generated for the secondary side with the help of a transformer driver such as Texas Instruments' [SN6501](#) or [SN6505A](#). For such applications, detailed power supply design and transformer selection recommendations are available in [SN6501 Transformer Driver for Isolated Power Supplies data sheet](#) and [SN6505A Low-Noise 1-A Transformer Drivers for Isolated Power Supplies data sheet](#).

13 Layout

13.1 Layout Guidelines

Designers must pay close attention to PCB layout to achieve optimum performance for the UCC53x0. Some key guidelines are:

- Component placement:
 - Low-ESR and low-ESL capacitors must be connected close to the device between the V_{CC1} and GND1 pins and between the V_{CC2} and V_{EE2} pins to bypass noise and to support high peak currents when turning on the external power transistor.
 - To avoid large negative transients on the V_{EE2} pins connected to the switch node, the parasitic inductances between the source of the top transistor and the source of the bottom transistor must be minimized.
- Grounding considerations:
 - Limiting the high peak currents that charge and discharge the transistor gates to a minimal physical area is essential. This limitation decreases the loop inductance and minimizes noise on the gate terminals of the transistors. The gate driver must be placed as close as possible to the transistors.
- High-voltage considerations:
 - To ensure isolation performance between the primary and secondary side, avoid placing any PCB traces or copper below the driver device. A PCB cutout or groove is recommended in order to prevent contamination that may compromise the isolation performance.
- Thermal considerations:
 - A large amount of power may be dissipated by the UCC53x0 if the driving voltage is high, the load is heavy, or the switching frequency is high (for more information, see the [Estimate Gate-Driver Power Loss](#) section). Proper PCB layout can help dissipate heat from the device to the PCB and minimize junction-to-board thermal impedance (θ_{JB}).
 - Increasing the PCB copper connecting to the V_{CC2} and V_{EE2} pins is recommended, with priority on maximizing the connection to V_{EE2} . However, the previously mentioned high-voltage PCB considerations must be maintained.
 - If the system has multiple layers, TI also recommends connecting the V_{CC2} and V_{EE2} pins to internal ground or power planes through multiple vias of adequate size. These vias should be located close to the IC pins to maximize thermal conductivity. However, keep in mind that no traces or coppers from different high voltage planes are overlapping.

13.2 Layout Example

Figure 63 shows a PCB layout example with the signals and key components labeled.

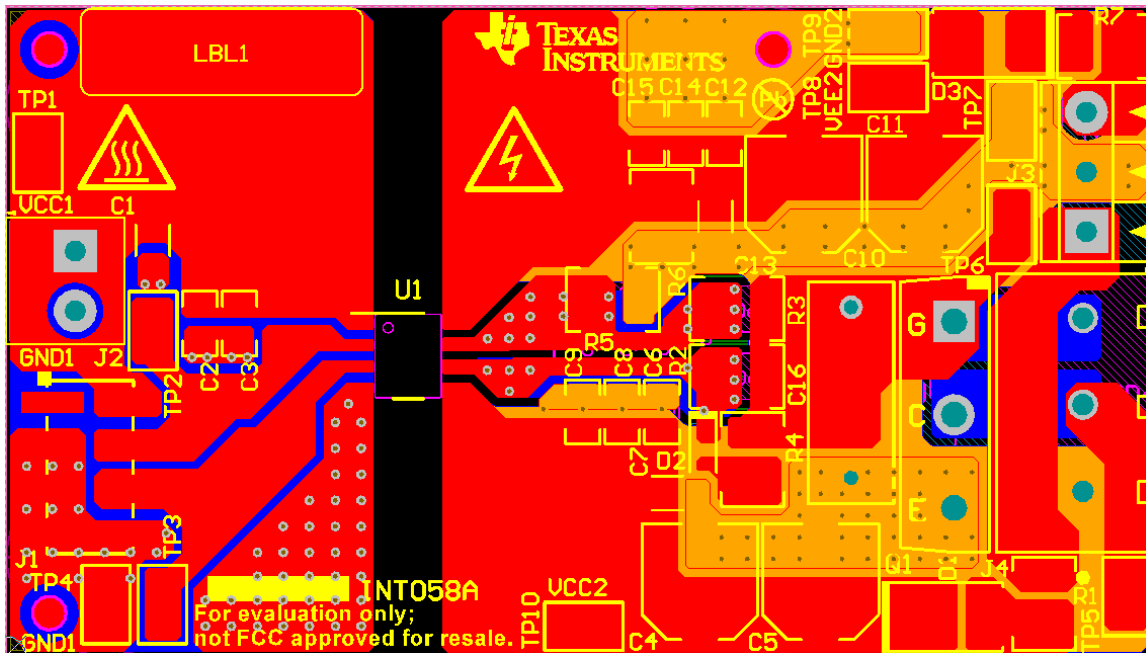

- (1) No PCB traces or copper are located between the primary and secondary side, which ensures isolation performance.

Figure 63. Layout Example

Layout Example (接下页)

图 64 和 图 65 显示顶层和底层走线和铜箔。



图 64. Top-Layer Traces and Copper



图 65. Bottom-Layer Traces and Copper (Flipped)

Layout Example (接下页)

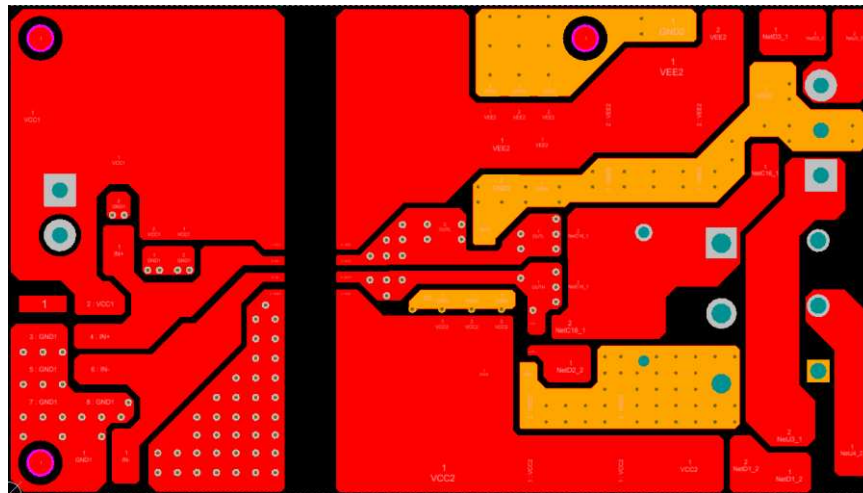
图 66 shows the 3D layout of the top view of the PCB.

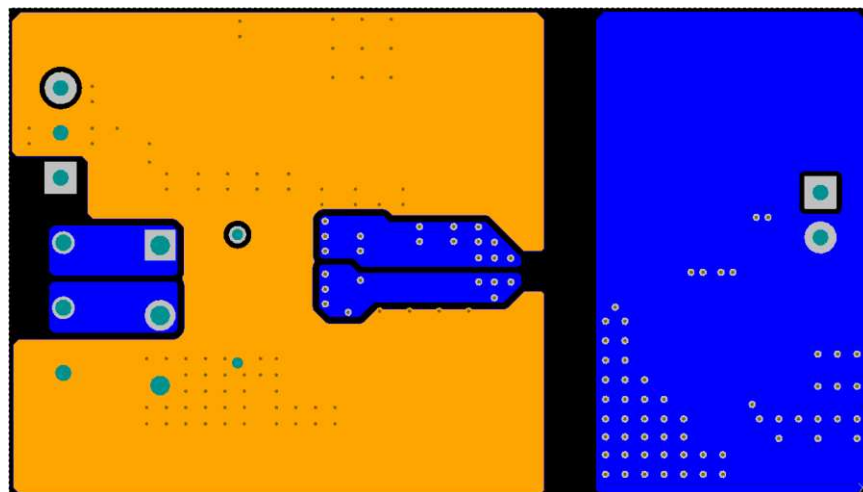
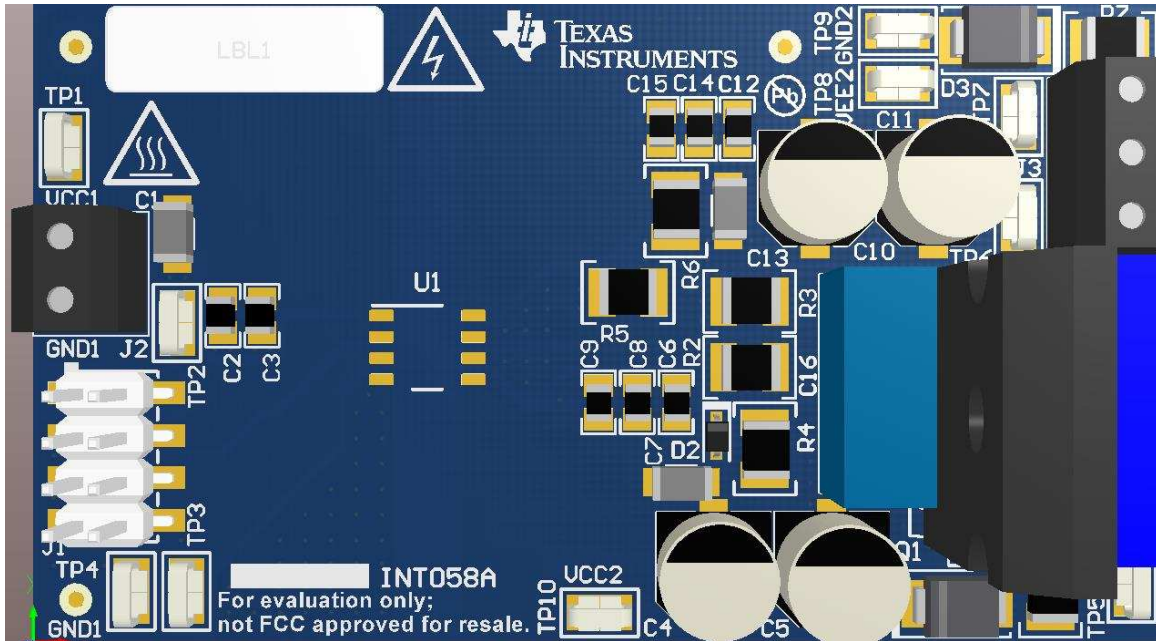

(1) The location of the PCB cutout between primary side and secondary sides ensures isolation performance.

图 66. 3-D PCB View

13.3 PCB Material

Use standard FR-4 UL94V-0 printed circuit board. This PCB is preferred over cheaper alternatives because of lower dielectric losses at high frequencies, less moisture absorption, greater strength and stiffness, and the self-extinguishing flammability-characteristics.

图 67 shows the recommended layer stack.



图 67. Recommended Layer Stack

14 器件和文档支持

14.1 文档支持

14.1.1 相关文档

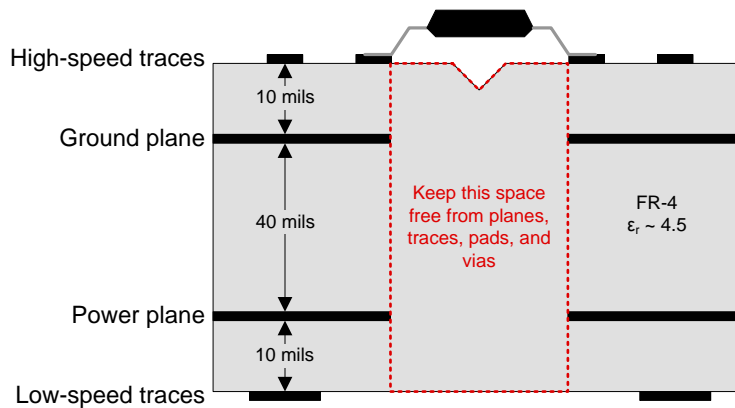
请参阅如下相关文档:

- 德州仪器 (TI), [《数字隔离器设计指南》](#)
- 德州仪器 (TI), [隔离相关术语](#)
- 德州仪器 (TI), [《SN6501 用于隔离式电源的变压器驱动器》数据表](#)
- 德州仪器 (TI), [《SN6505A 用于隔离式电源的低噪声 1A 变压器驱动器》数据表](#)
- 德州仪器 (TI), [UCC53x0xD 评估模块用户指南](#)

14.2 认证

UL 在线认证目录, [“FPPT2.E181974 非光学隔离器件 - 组件”证书编号: 20170718-E181974,](#)

14.3 相关链接

下表列出了快速访问链接。类别包括技术文档、支持和社区资源、工具和软件, 以及立即订购快速访问。

表 7. 相关链接

器件	产品文件夹	立即订购	技术文档	工具与软件	支持和社区
UCC5310	请单击此处	请单击此处	请单击此处	请单击此处	请单击此处
UCC5320	请单击此处	请单击此处	请单击此处	请单击此处	请单击此处
UCC5350	请单击此处	请单击此处	请单击此处	请单击此处	请单击此处
UCC5390	请单击此处	请单击此处	请单击此处	请单击此处	请单击此处

14.4 接收文档更新通知

要接收文档更新通知, 请导航至 [TI.com.cn](#) 上的器件产品文件夹。单击右上角的 [通知我](#) 进行注册, 即可每周接收产品信息更改摘要。有关更改的详细信息, 请查看任何已修订文档中包含的修订历史记录。

14.5 社区资源

下列链接提供到 TI 社区资源的连接。链接的内容由各个分销商“按照原样”提供。这些内容并不构成 TI 技术规范, 并且不一定反映 TI 的观点; 请参阅 TI 的 [《使用条款》](#)。

TI E2E™ 在线社区 [TI 的工程师对工程师 \(E2E\) 社区](#)。此社区的创建目的在于促进工程师之间的协作。在 [e2e.ti.com](#) 中, 您可以咨询问题、分享知识、拓展思路并与同行工程师一道帮助解决问题。

设计支持 [TI 参考设计支持](#) 可帮助您快速查找有帮助的 E2E 论坛、设计支持工具以及技术支持的联系信息。

14.6 商标

E2E is a trademark of Texas Instruments.
All other trademarks are the property of their respective owners.

14.7 静电放电警告



ESD 可能会损坏该集成电路。德州仪器 (TI) 建议通过适当的预防措施处理所有集成电路。如果不遵守正确的处理措施和安装程序, 可能会损坏集成电路。

ESD 的损坏小至导致微小的性能降级, 大至整个器件故障。精密的集成电路可能更容易受到损坏, 这是因为非常细微的参数更改都可能会导致器件与其发布的规格不相符。

14.8 术语表

SLYZ022 — [TI 术语表](#)。

这份术语表列出并解释术语、缩写和定义。

15 机械、封装和可订购信息

以下页面包含机械、封装和可订购信息。这些信息是指定器件的最新可用数据。数据如有变更，恕不另行通知，且不会对此文档进行修订。如需获取此数据表的浏览器版本，请查阅左侧的导航栏。

D0008B
PACKAGE OUTLINE
SOIC - 1.75 mm max height

SOIC

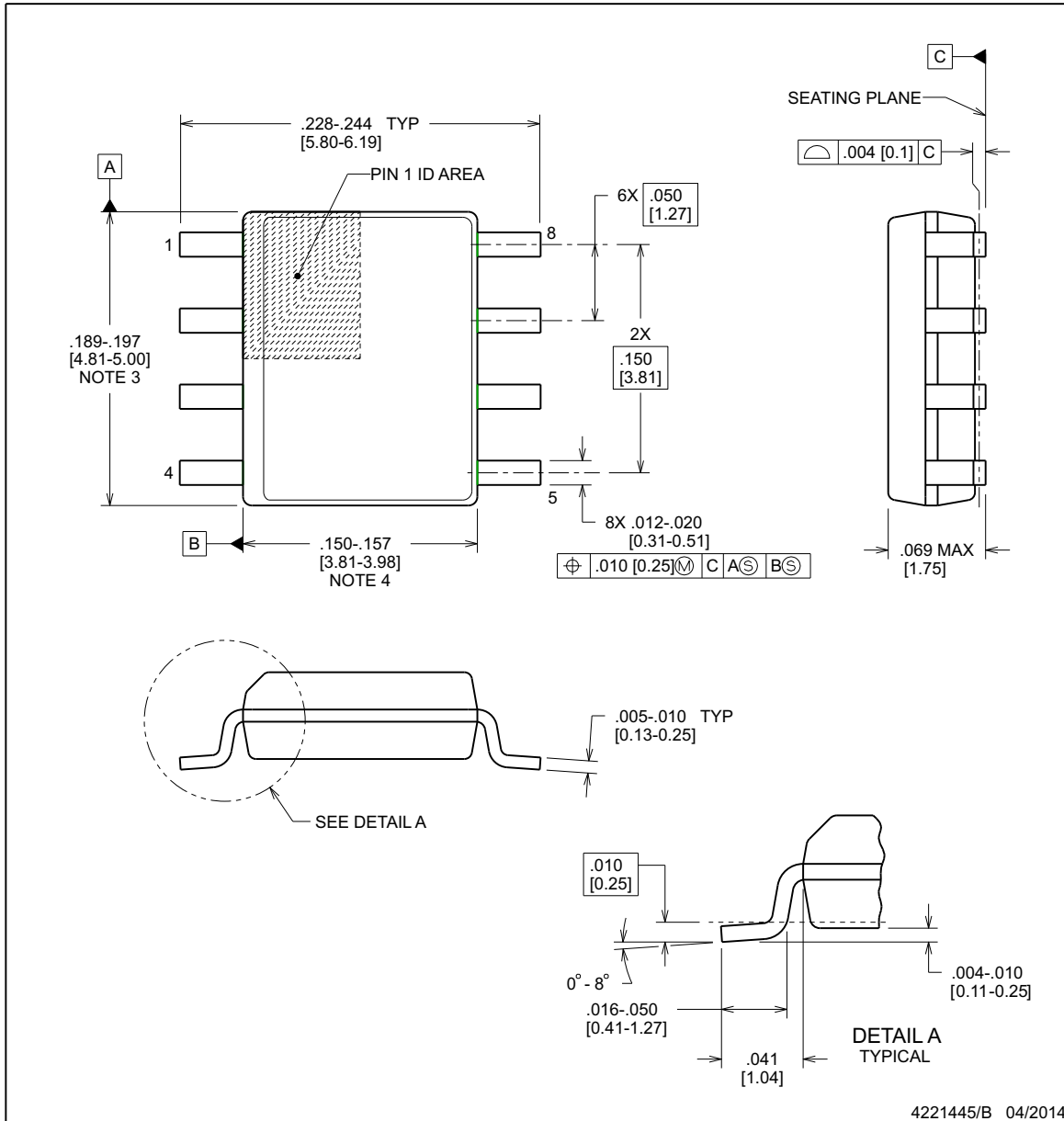
NOTES:

1. Linear dimensions are in inches [millimeters]. Dimensions in parenthesis are for reference only. Controlling dimensions are in inches. Dimensioning and tolerancing per ASME Y14.5M.
2. This drawing is subject to change without notice.
3. This dimension does not include mold flash, protrusions, or gate burrs. Mold flash, protrusions, or gate burrs shall not exceed $.006$ [0.15], per side.
4. This dimension does not include interlead flash.
5. Reference JEDEC registration MS-012, variation AA.

EXAMPLE BOARD LAYOUT

D0008B

SOIC - 1.75 mm max height

SOIC

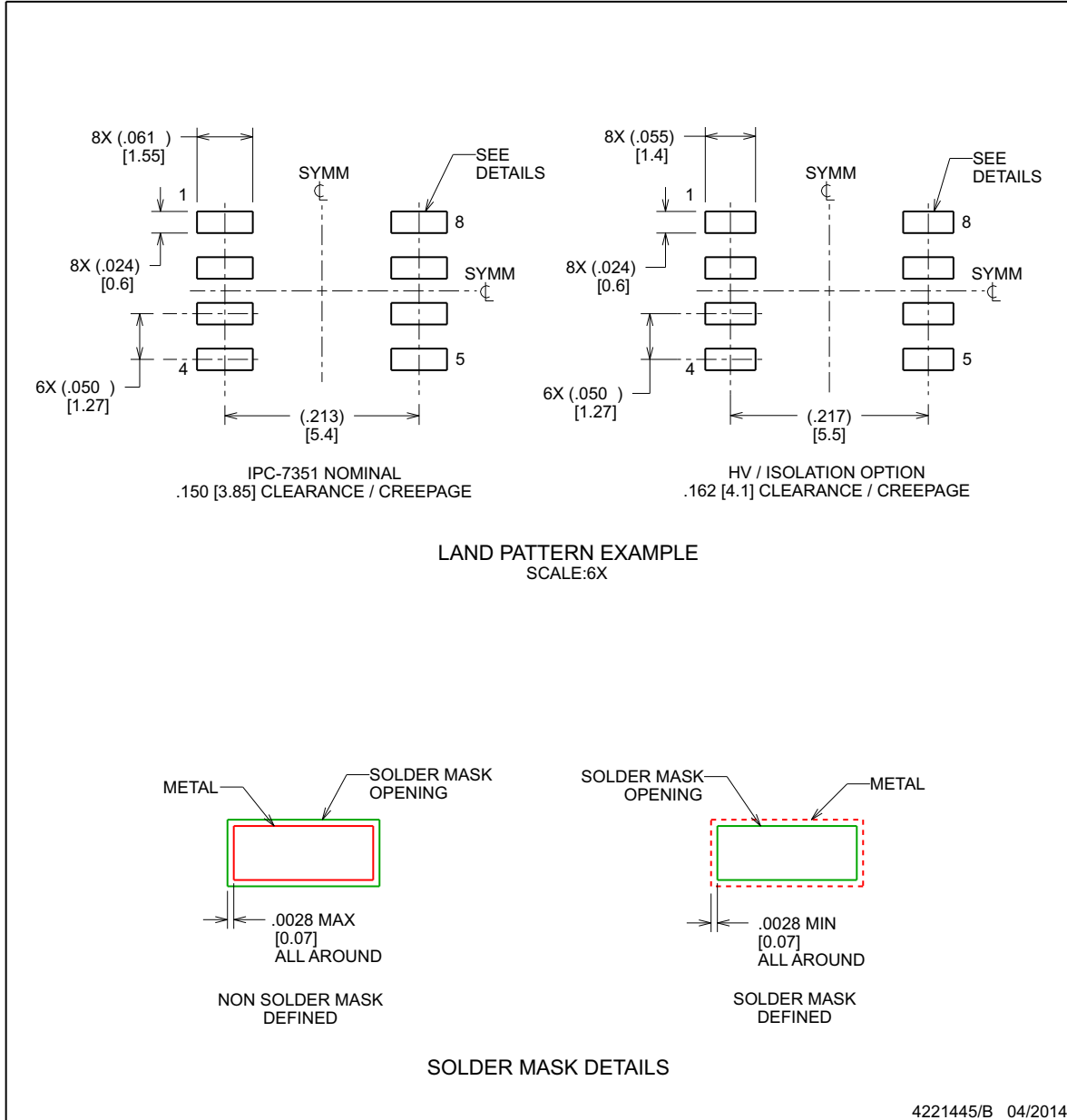

NOTES: (continued)

- 6. Publication IPC-7351 may have alternate designs.
- 7. Solder mask tolerances between and around signal pads can vary based on board fabrication site.

EXAMPLE STENCIL DESIGN

D0008B
SOIC - 1.75 mm max height

SOIC

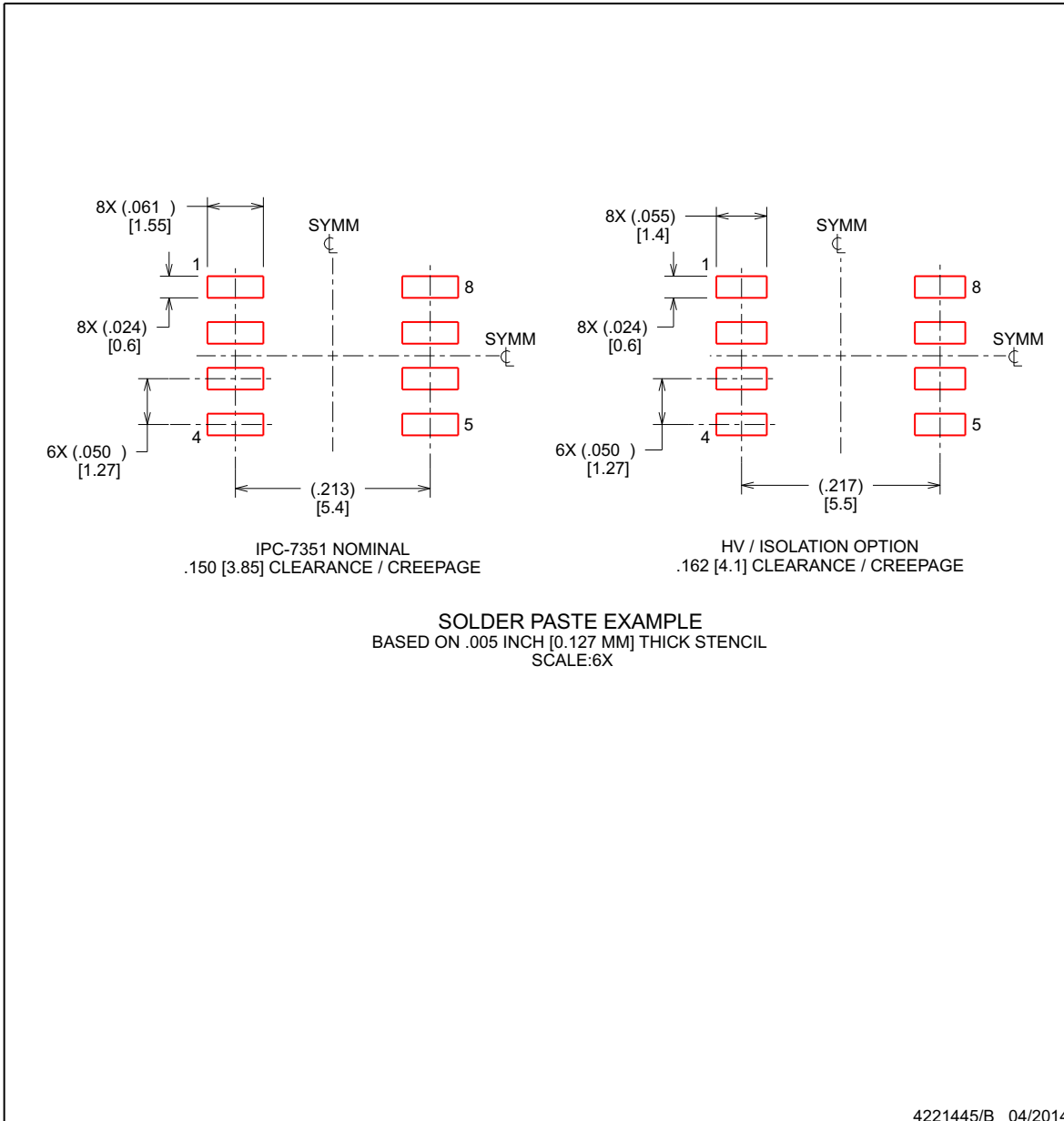

NOTES: (continued)

8. Laser cutting apertures with trapezoidal walls and rounded corners may offer better paste release. IPC-7525 may have alternate design recommendations.
9. Board assembly site may have different recommendations for stencil design.

PACKAGING INFORMATION

Orderable Device	Status (1)	Package Type	Package Drawing	Pins	Package Qty	Eco Plan (2)	Lead finish/ Ball material (6)	MSL Peak Temp (3)	Op Temp (°C)	Device Marking (4/5)	Samples
UCC5310MCD	ACTIVE	SOIC	D	8	75	RoHS & Green	NIPDAU	Level-2-260C-1 YEAR	-40 to 125	5310M	Samples
UCC5310MCDR	ACTIVE	SOIC	D	8	2500	RoHS & Green	NIPDAU	Level-2-260C-1 YEAR	-40 to 125	5310M	Samples
UCC5310MCDWV	ACTIVE	SOIC	DWV	8	64	RoHS & Green	NIPDAU	Level-2-260C-1 YEAR	-40 to 125	5310MC	Samples
UCC5310MCDWVR	ACTIVE	SOIC	DWV	8	1000	RoHS & Green	NIPDAU	Level-2-260C-1 YEAR	-40 to 125	5310MC	Samples
UCC5320ECD	ACTIVE	SOIC	D	8	75	RoHS & Green	NIPDAU	Level-2-260C-1 YEAR	-40 to 125	5320E	Samples
UCC5320ECDR	ACTIVE	SOIC	D	8	2500	RoHS & Green	NIPDAU	Level-2-260C-1 YEAR	-40 to 125	5320E	Samples
UCC5320SCD	ACTIVE	SOIC	D	8	75	RoHS & Green	NIPDAU	Level-2-260C-1 YEAR	-40 to 125	5320S	Samples
UCC5320SCDR	ACTIVE	SOIC	D	8	2500	RoHS & Green	NIPDAU	Level-2-260C-1 YEAR	-40 to 125	5320S	Samples
UCC5320SCDWV	ACTIVE	SOIC	DWV	8	64	RoHS & Green	NIPDAU	Level-2-260C-1 YEAR	-40 to 125	5320SC	Samples
UCC5320SCDWVR	ACTIVE	SOIC	DWV	8	1000	RoHS & Green	NIPDAU	Level-2-260C-1 YEAR	-40 to 125	5320SC	Samples
UCC5350MCD	ACTIVE	SOIC	D	8	75	RoHS & Green	NIPDAU	Level-2-260C-1 YEAR	-40 to 125	5350M	Samples
UCC5350MCDR	ACTIVE	SOIC	D	8	2500	RoHS & Green	NIPDAU	Level-2-260C-1 YEAR	-40 to 125	5350M	Samples
UCC5350MCDWV	ACTIVE	SOIC	DWV	8	64	RoHS & Green	NIPDAU	Level-2-260C-1 YEAR	-40 to 125	5350MC	Samples
UCC5350MCDWVR	ACTIVE	SOIC	DWV	8	1000	RoHS & Green	NIPDAU	Level-2-260C-1 YEAR	-40 to 125	5350MC	Samples
UCC5350SBD	ACTIVE	SOIC	D	8	75	RoHS & Green	NIPDAU	Level-2-260C-1 YEAR	-40 to 125	5350SB	Samples
UCC5350SBDR	ACTIVE	SOIC	D	8	2500	RoHS & Green	NIPDAU	Level-2-260C-1 YEAR	-40 to 125	5350SB	Samples
UCC5390ECD	ACTIVE	SOIC	D	8	75	RoHS & Green	NIPDAU	Level-2-260C-1 YEAR	-40 to 125	53X0E	Samples
UCC5390ECDR	ACTIVE	SOIC	D	8	2500	RoHS & Green	NIPDAU	Level-2-260C-1 YEAR	-40 to 125	53X0E	Samples
UCC5390ECDWV	ACTIVE	SOIC	DWV	8	64	RoHS & Green	NIPDAU	Level-2-260C-1 YEAR	-40 to 125	5390EC	Samples
UCC5390ECDWVR	ACTIVE	SOIC	DWV	8	1000	RoHS & Green	NIPDAU	Level-2-260C-1 YEAR	-40 to 125	5390EC	Samples

Orderable Device	Status (1)	Package Type	Package Drawing	Pins	Package Qty	Eco Plan (2)	Lead finish/ Ball material (6)	MSL Peak Temp (3)	Op Temp (°C)	Device Marking (4/5)	Samples
UCC5390SCD	ACTIVE	SOIC	D	8	75	RoHS & Green	NIPDAU	Level-2-260C-1 YEAR	-40 to 125	53X0S	Samples
UCC5390SCDR	ACTIVE	SOIC	D	8	2500	RoHS & Green	NIPDAU	Level-2-260C-1 YEAR	-40 to 125	53X0S	Samples

(1) The marketing status values are defined as follows:

ACTIVE: Product device recommended for new designs.

LIFEBUY: TI has announced that the device will be discontinued, and a lifetime-buy period is in effect.

NRND: Not recommended for new designs. Device is in production to support existing customers, but TI does not recommend using this part in a new design.

PREVIEW: Device has been announced but is not in production. Samples may or may not be available.

OBSOLETE: TI has discontinued the production of the device.

(2) **RoHS:** TI defines "RoHS" to mean semiconductor products that are compliant with the current EU RoHS requirements for all 10 RoHS substances, including the requirement that RoHS substance do not exceed 0.1% by weight in homogeneous materials. Where designed to be soldered at high temperatures, "RoHS" products are suitable for use in specified lead-free processes. TI may reference these types of products as "Pb-Free".

RoHS Exempt: TI defines "RoHS Exempt" to mean products that contain lead but are compliant with EU RoHS pursuant to a specific EU RoHS exemption.

Green: TI defines "Green" to mean the content of Chlorine (Cl) and Bromine (Br) based flame retardants meet JS709B low halogen requirements of <=1000ppm threshold. Antimony trioxide based flame retardants must also meet the <=1000ppm threshold requirement.

(3) MSL, Peak Temp. - The Moisture Sensitivity Level rating according to the JEDEC industry standard classifications, and peak solder temperature.

(4) There may be additional marking, which relates to the logo, the lot trace code information, or the environmental category on the device.

(5) Multiple Device Markings will be inside parentheses. Only one Device Marking contained in parentheses and separated by a "~" will appear on a device. If a line is indented then it is a continuation of the previous line and the two combined represent the entire Device Marking for that device.

(6) Lead finish/Ball material - Orderable Devices may have multiple material finish options. Finish options are separated by a vertical ruled line. Lead finish/Ball material values may wrap to two lines if the finish value exceeds the maximum column width.

Important Information and Disclaimer: The information provided on this page represents TI's knowledge and belief as of the date that it is provided. TI bases its knowledge and belief on information provided by third parties, and makes no representation or warranty as to the accuracy of such information. Efforts are underway to better integrate information from third parties. TI has taken and continues to take reasonable steps to provide representative and accurate information but may not have conducted destructive testing or chemical analysis on incoming materials and chemicals. TI and TI suppliers consider certain information to be proprietary, and thus CAS numbers and other limited information may not be available for release.

In no event shall TI's liability arising out of such information exceed the total purchase price of the TI part(s) at issue in this document sold by TI to Customer on an annual basis.

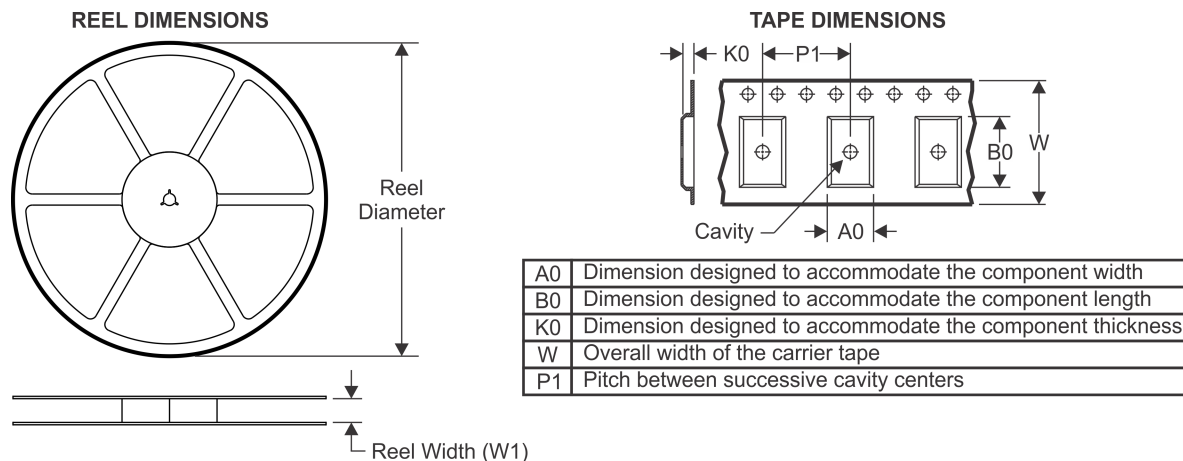
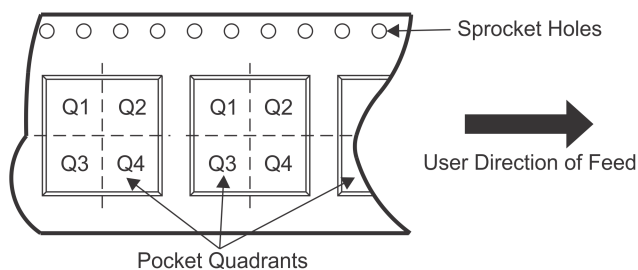
TAPE AND REEL INFORMATION

QUADRANT ASSIGNMENTS FOR PIN 1 ORIENTATION IN TAPE

*All dimensions are nominal

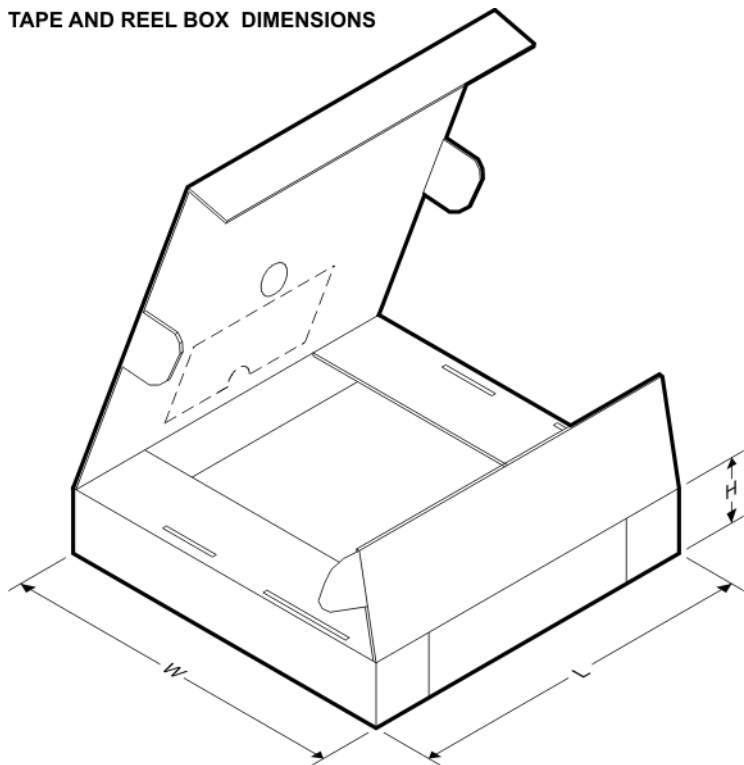
Device	Package Type	Package Drawing	Pins	SPQ	Reel Diameter (mm)	Reel Width W1 (mm)	A0 (mm)	B0 (mm)	K0 (mm)	P1 (mm)	W (mm)	Pin1 Quadrant
UCC5310MCDR	SOIC	D	8	2500	330.0	12.4	6.4	5.2	2.1	8.0	12.0	Q1
UCC5310MCDWVR	SOIC	DWV	8	1000	330.0	16.4	12.05	6.15	3.3	16.0	16.0	Q1
UCC5320ECDR	SOIC	D	8	2500	330.0	12.4	6.4	5.2	2.1	8.0	12.0	Q1
UCC5320SCDR	SOIC	D	8	2500	330.0	12.4	6.4	5.2	2.1	8.0	12.0	Q1
UCC5320SCDWVR	SOIC	DWV	8	1000	330.0	16.4	12.05	6.15	3.3	16.0	16.0	Q1
UCC5350MCDR	SOIC	D	8	2500	330.0	12.4	6.4	5.2	2.1	8.0	12.0	Q1
UCC5350MCDWVR	SOIC	DWV	8	1000	330.0	16.4	12.05	6.15	3.3	16.0	16.0	Q1
UCC5350SBDR	SOIC	D	8	2500	330.0	12.4	6.4	5.2	2.1	8.0	12.0	Q1
UCC5390ECDR	SOIC	D	8	2500	330.0	12.4	6.4	5.2	2.1	8.0	12.0	Q1
UCC5390ECDWVR	SOIC	DWV	8	1000	330.0	16.4	12.05	6.15	3.3	16.0	16.0	Q1
UCC5390SCDR	SOIC	D	8	2500	330.0	12.4	6.4	5.2	2.1	8.0	12.0	Q1

TAPE AND REEL BOX DIMENSIONS

*All dimensions are nominal

Device	Package Type	Package Drawing	Pins	SPQ	Length (mm)	Width (mm)	Height (mm)
UCC5310MCDR	SOIC	D	8	2500	350.0	350.0	43.0
UCC5310MCDWVR	SOIC	DWV	8	1000	350.0	350.0	43.0
UCC5320ECDR	SOIC	D	8	2500	350.0	350.0	43.0
UCC5320SCDR	SOIC	D	8	2500	350.0	350.0	43.0
UCC5320SCDWVR	SOIC	DWV	8	1000	350.0	350.0	43.0
UCC5350MCDR	SOIC	D	8	2500	350.0	350.0	43.0
UCC5350MCDWVR	SOIC	DWV	8	1000	350.0	350.0	43.0
UCC5350SBDR	SOIC	D	8	2500	350.0	350.0	43.0
UCC5390ECDR	SOIC	D	8	2500	350.0	350.0	43.0
UCC5390ECDWVR	SOIC	DWV	8	1000	350.0	350.0	43.0
UCC5390SCDR	SOIC	D	8	2500	350.0	350.0	43.0

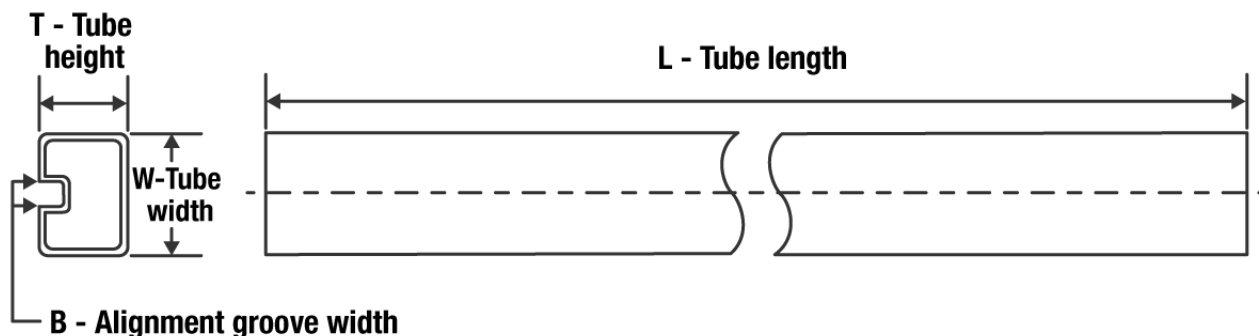
TUBE

*All dimensions are nominal

Device	Package Name	Package Type	Pins	SPQ	L (mm)	W (mm)	T (μm)	B (mm)
UCC5310MCD	D	SOIC	8	75	505.46	6.76	3810	4
UCC5310MCDWV	DWV	SOIC	8	64	505.46	13.94	4826	6.6
UCC5320ECD	D	SOIC	8	75	505.46	6.76	3810	4
UCC5320SCD	D	SOIC	8	75	505.46	6.76	3810	4
UCC5320SCDWV	DWV	SOIC	8	64	505.46	13.94	4826	6.6
UCC5350MCD	D	SOIC	8	75	505.46	6.76	3810	4
UCC5350MCDWV	DWV	SOIC	8	64	505.46	13.94	4826	6.6
UCC5350SBD	D	SOIC	8	75	505.46	6.76	3810	4
UCC5390ECD	D	SOIC	8	75	505.46	6.76	3810	4
UCC5390ECDWV	DWV	SOIC	8	64	505.46	13.94	4826	6.6
UCC5390SCD	D	SOIC	8	75	505.46	6.76	3810	4

PACKAGE OUTLINE

DWV0008A



SOIC - 2.8 mm max height

SOIC

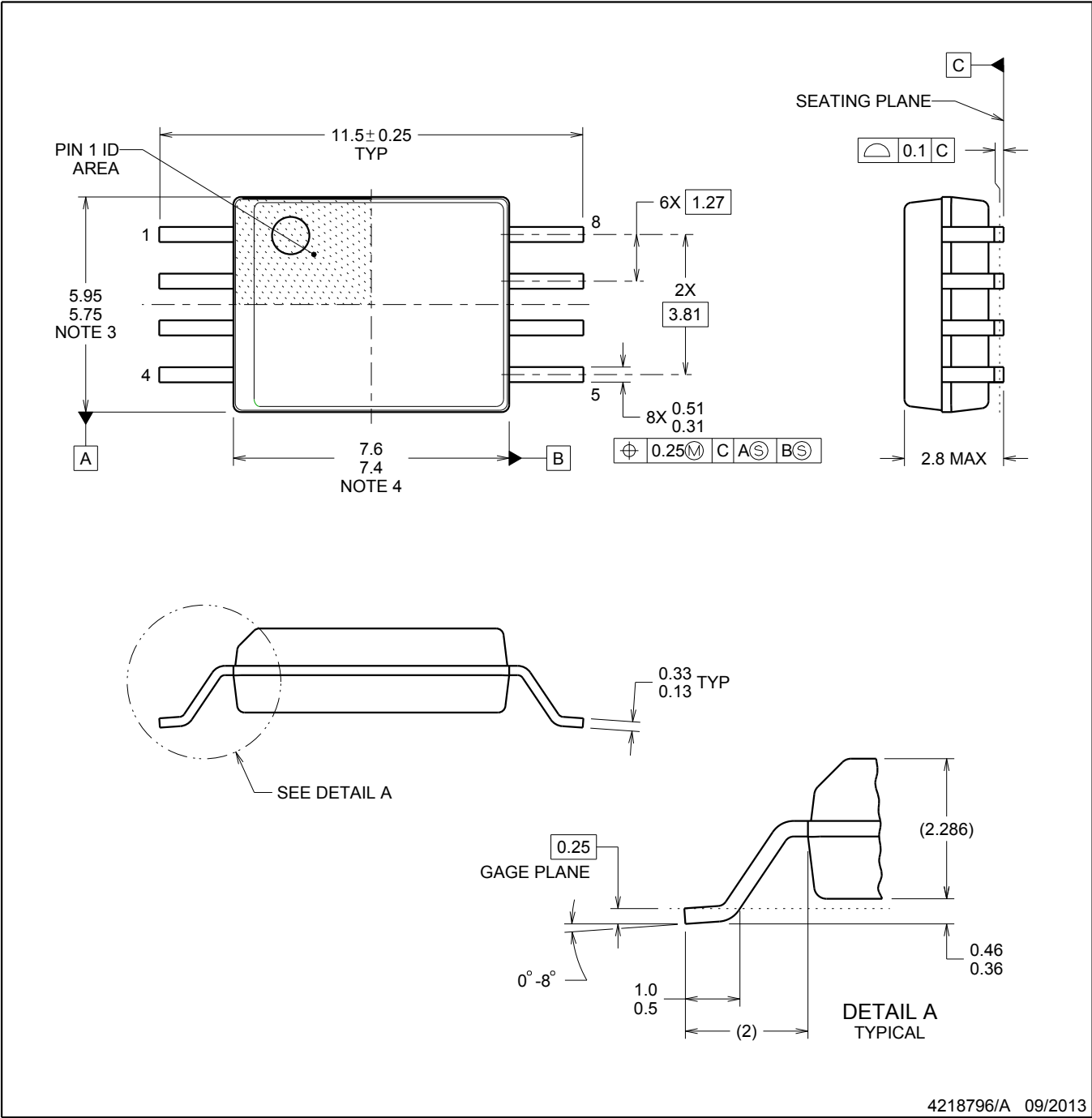

NOTES:

1. All linear dimensions are in millimeters. Dimensions in parenthesis are for reference only. Dimensioning and tolerancing per ASME Y14.5M.
2. This drawing is subject to change without notice.
3. This dimension does not include mold flash, protrusions, or gate burrs. Mold flash, protrusions, or gate burrs shall not exceed 0.15 mm, per side.
4. This dimension does not include interlead flash. Interlead flash shall not exceed 0.25 mm, per side.

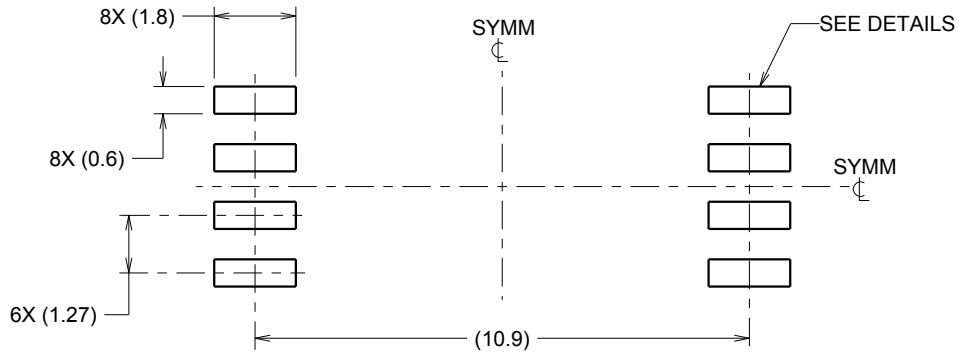

LAND PATTERN EXAMPLE
 9.1 mm NOMINAL CLEARANCE/CREEPAGE
 SCALE:6X

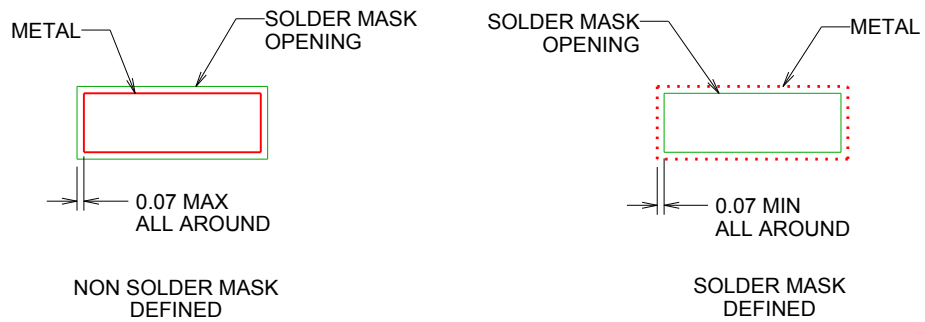

SOLDER MASK DETAILS

4218796/A 09/2013

NOTES: (continued)

- 5. Publication IPC-7351 may have alternate designs.
- 6. Solder mask tolerances between and around signal pads can vary based on board fabrication site.

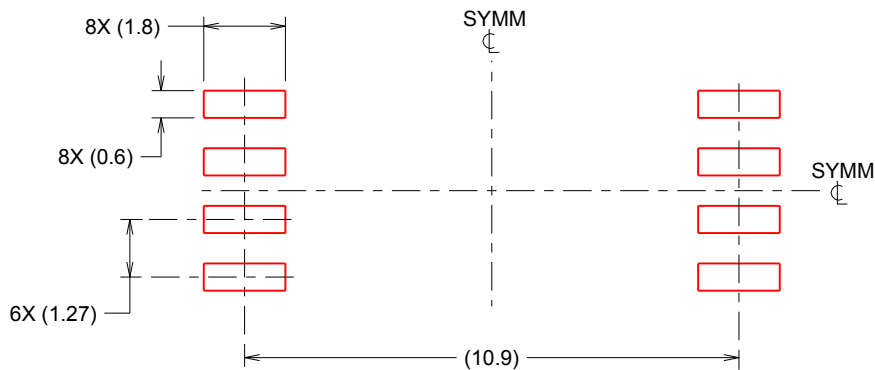

SOLDER PASTE EXAMPLE
 BASED ON 0.125 mm THICK STENCIL
 SCALE:6X

4218796/A 09/2013

NOTES: (continued)

- 7. Laser cutting apertures with trapezoidal walls and rounded corners may offer better paste release. IPC-7525 may have alternate design recommendations.
- 8. Board assembly site may have different recommendations for stencil design.



D0008A

PACKAGE OUTLINE

SOIC - 1.75 mm max height

SMALL OUTLINE INTEGRATED CIRCUIT



4214825/C 02/2019

NOTES:

- Linear dimensions are in inches [millimeters]. Dimensions in parenthesis are for reference only. Controlling dimensions are in inches. Dimensioning and tolerancing per ASME Y14.5M.
- This drawing is subject to change without notice.
- This dimension does not include mold flash, protrusions, or gate burrs. Mold flash, protrusions, or gate burrs shall not exceed $.006$ [0.15] per side.
- This dimension does not include interlead flash.
- Reference JEDEC registration MS-012, variation AA.

EXAMPLE BOARD LAYOUT

D0008A

SOIC - 1.75 mm max height

SMALL OUTLINE INTEGRATED CIRCUIT



LAND PATTERN EXAMPLE
EXPOSED METAL SHOWN
SCALE:8X



SOLDER MASK DETAILS

4214825/C 02/2019

NOTES: (continued)

6. Publication IPC-7351 may have alternate designs.

7. Solder mask tolerances between and around signal pads can vary based on board fabrication site.

EXAMPLE STENCIL DESIGN

D0008A

SOIC - 1.75 mm max height

SMALL OUTLINE INTEGRATED CIRCUIT



SOLDER PASTE EXAMPLE
BASED ON .005 INCH [0.125 MM] THICK STENCIL
SCALE:8X

4214825/C 02/2019

NOTES: (continued)

8. Laser cutting apertures with trapezoidal walls and rounded corners may offer better paste release. IPC-7525 may have alternate design recommendations.
9. Board assembly site may have different recommendations for stencil design.

重要声明和免责声明

TI“按原样”提供技术和可靠性数据（包括数据表）、设计资源（包括参考设计）、应用或其他设计建议、网络工具、安全信息和其他资源，不保证没有瑕疵且不做任何明示或暗示的担保，包括但不限于对适销性、某特定用途方面的适用性或不侵犯任何第三方知识产权的暗示担保。

这些资源可供使用 TI 产品进行设计的熟练开发人员使用。您将自行承担以下全部责任：(1) 针对您的应用选择合适的 TI 产品，(2) 设计、验证并测试您的应用，(3) 确保您的应用满足相应标准以及任何其他功能安全、信息安全、监管或其他要求。

这些资源如有变更，恕不另行通知。TI 授权您仅可将这些资源用于研发本资源所述的 TI 产品的应用。严禁对这些资源进行其他复制或展示。您无权使用任何其他 TI 知识产权或任何第三方知识产权。您应全额赔偿因在这些资源的使用中对 TI 及其代表造成的任何索赔、损害、成本、损失和债务，TI 对此概不负责。

TI 提供的产品受 [TI 的销售条款](#) 或 [ti.com](#) 上其他适用条款/TI 产品随附的其他适用条款的约束。TI 提供这些资源并不会扩展或以其他方式更改 TI 针对 TI 产品发布的适用的担保或担保免责声明。

TI 反对并拒绝您可能提出的任何其他或不同的条款。

邮寄地址：Texas Instruments, Post Office Box 655303, Dallas, Texas 75265

Copyright © 2022，德州仪器 (TI) 公司