

# ***XIO1100***

## ***Data Manual***

Literature Number: SLLS690C  
April 2006 Revised August 2011



---

## Contents

<i>Section</i>	<i>Page</i>
<b>1 XIO1100 Features</b> .....	<b>1</b>
<b>2 Description</b> .....	<b>1</b>
2.1 Ordering Information .....	1
2.2 Functional Description .....	2
2.3 Power Management .....	2
2.3.1 P0 .....	3
2.3.2 P0s .....	3
2.3.3 P1 .....	3
2.4 Clock .....	3
2.5 Reset .....	3
2.6 Receiver Detection .....	4
2.7 Receiver Clock Tolerance Compensation .....	4
2.8 Error Detection .....	4
2.8.1 8B/10B Decode Error .....	5
2.8.2 Elastic Buffer Overflow Error .....	5
2.8.3 Elastic Buffer Underflow Error .....	5
2.8.4 Disparity Error .....	5
2.9 Loopback .....	5
2.10 Electrical Idle .....	5
2.11 Polarity Inversion .....	5
2.12 Setting Negative Parity .....	5
2.13 Terminal Assignments .....	6
2.14 Terminal Descriptions .....	8
<b>3 Electrical Characteristics</b> .....	<b>12</b>
3.1 Absolute Maximum Ratings† .....	12
3.2 Recommended Operating Conditions .....	12
3.3 PCI Express Differential Transmitter Output Ranges .....	13
3.4 PCI Express Differential Receiver Input Ranges .....	15
3.5 Express Differential Reference Clock Input Ranges .....	18
3.6 Electrical Characteristics Over Recommended Operating Conditions (VDD_IO) .....	19
3.7 Implementation-Specific Timing .....	19
<b>4 Timing Diagrams</b> .....	<b>20</b>
<b>5 Application Information</b> .....	<b>24</b>
5.1 Component Connection .....	24
5.2 XIO1100 Component Placement .....	25
5.3 Power Supply Filtering Recommendations .....	25
5.4 PCIe Layout Guidelines .....	27
5.5 PIPE Interface Layout Guidelines .....	28
<b>6 Mechanical Data</b> .....	<b>29</b>

---

## List of Figures

<i>Figure</i>	<i>Page</i>
Figure 2-1. XIO1100 Functional Block Diagram .....	2
Figure 4-1. TI-PIPE Input Timing .....	20
Figure 4-2. TI-PIPE Data Output Timing .....	21
Figure 4-3. TI-PIPE Output Functional Timing .....	22
Figure 4-4. TI-PIPE Input Functional Timing .....	23
Figure 5-1. External Component Connections .....	24
Figure 5-2. Filter Designs .....	26

---

## List of Tables

<i>Table</i>	<i>Page</i>
Table 2-1. Clock Selection .....	3
Table 2-2. RX_STATUS Loopback Detection Code .....	4
Table 2-3. 100-pin GGB Signal Name Sorted by Terminal Number .....	6
Table 2-4. 100-pin GGB Signal Name Sorted Alphabetically .....	7
Table 2-5. XIO1100 Terminals .....	8

## 1 XIO1100 Features

- **X1 PCI Express™ Serial Link**
  - PCI Express 1.1 Compliant
  - Selectable Reference Clock (100 MHz, 125 MHz)
  - Low-Power Capability
- **TI-PIPE MAC Interface**
  - Source-Synchronous TX and RX Ports
  - 125 MHz TX/RX Clocks
  - Selectable 16-Bit SDR or 8-Bit DDR Mode
- **100-Pin MicroStar™ BGA Package**
- **Selectable 1.5-V or 1.8-V LVCMOS Buffers.**

TI and MicroStar BGA are trademarks of Texas Instruments Incorporated  
PCI Express is a trademark of PCI-SIG

## 2 Description

The XIO1100 is a PCI Express™ PHY that is compliant with *PCI Express Base Specification Revision 1.1* and that interfaces the PCI Express Media Access Layer (MAC) to a PCI Express serial link by using a modified version of the interface described in *PHY Interface for the PCI Express™ Architecture* (also known as PIPE interface) by Intel Corporation. This modified version of the PIPE interface is referred to as a TI-PIPE interface throughout this data manual.

The TI-PIPE interface is a pin-configurable interface that can be configured as either a 16-bit or an 8-bit interface.

- The 16-bit TI-PIPE interface is a 125 MHz 16-bit parallel interface with a 16-bit output bus (RXDATA) that is clocked by the RXCLK output clock and a 16-bit input bus (TXDATA) that is clocked by the TXCLK input clock. Both buses are clocked using Single Data Rate (SDR) clocking in which the data transitions are on the rising edge of the associated clock.
- The 8-bit TI-PIPE interface is a 250 MHz 8-bit parallel interface with an 8-bit output bus (RXDATA) that is clocked by the RXCLK output clock and an 8-bit input bus (TXDATA) that is clocked by the TXCLK input clock. Both buses are clocked using Double Data Rate (DDR) clocking in which the data transitions are on both the rising edge and the falling edge of the clock.

The XIO1100 PHY interfaces to a 2.5 Gbps PCI Express serial link with a transmit differential pair (TXP and TXN) and a receive differential pair (RXP and RXN). Incoming data at the XIO1100 PHY receive differential pair (RXP and RXN) is forwarded to the MAC on the RXDATA output bus. Data received from the MAC on the TXDATA input bus is forwarded to the XIO1100 PHY transfer differential pair (TXP and TXN).

The XIO1100 is also responsible for handling the 8B/10B encoding/decoding and scrambling/unscrambling of the outgoing data. In addition, XIO1100 can recover/interpolate the clock on the receiver side based on the transitions guaranteed by the use of the 8B/10B mechanism and supply this to the receive side of the data link layer logic.

In addition to the TI-PIPE interface, the XIO1100 has some TI-proprietary side-band signals that some customers may wish to use to take advantage of additional XIO1100 low-power state features (for example, disabling the PLL during the L1 power state).

### 2.1 Ordering Information

ORDERING NUMBER	VOLTAGE	TEMPERATURE	PACKAGE
XIO1100	3.3/1.8/1.5	0°C to 70°C	100-terminal GGB

## 2.2 Functional Description

The XIO1100 meets all of the requirements for a PCI-Express PHY as defined by Section 4, Physical Layer Specifications, of the PCI-SIG document *PCI Express Base Specification*. The XIO1100 conforms to the functional behavior described in *PHY Interface for the PCI Express™ Architecture* by Intel Corporation. There are only two differences between the XIO1100 TI-PIPE interface and the Intel PIPE interface.

The PIPE interface uses a single SDR clock source to clock both the RXDATA and the TXDATA. The TI-PIPE interface uses two source synchronous clocks, RX\_CLK and TX\_CLK, to clock the RXDATA and TXDATA. RXDATA uses RX\_CLK and TXDATA uses TX\_CLK.

In the 8-bit mode, the TI-PIPE interface is a DDR (Double Data Rate) interface. In the 16-bit mode, it is an SDR (Single Data Rate) interface. The PIPE interface is always an SDR interface.

Figure 2-1 shows a functional block diagram of the XIO1100.

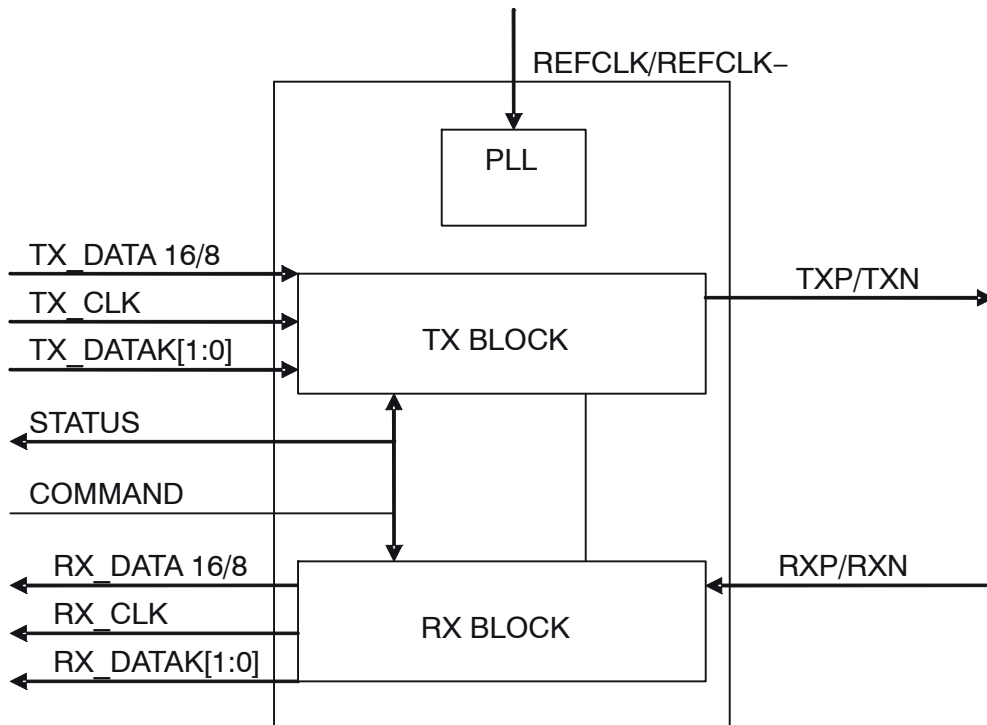

Figure 2-1. XIO1100 Functional Block Diagram

## 2.3 Power Management

The three power states are:

- P0
- P0s
- P1

### 2.3.1 P0

P0 is the normal operation state for the XIO1100. The POWERDOWN[1:0] input signals define which of the three power states that an XIO110 is in at any given time. In states P0, P0s, and P1, the XIO1100 is required to keep P\_CLK operational. For all state transitions between these three states, the XIO1100 indicates successful transition into the designated power state by a single cycle assertion of PHY\_STATUS. For all power state transitions, the MAC must not begin any operational sequence or more power state transitions until the XIO1100 has indicated that the initial state transition is finished. P2 state and beacon are not supported.

In the P0 state, all internal clocks in the XIO1100 are operational. P0 is the only state where the XIO1100 transmits and receives PCI Express signaling. P0 is the appropriate PHY power management state for most states in the Link Training and Status State Machine (LTSSM). Exceptions are listed as follows for each lower power XIO1100 state.

### 2.3.2 P0s

In the P0s state, RX\_CLK output stays operational. The MAC moves the XIO1100 to this state only when the transmit channel is idle. P0s state is used when the transmitter is in state Tx\_L0s.Idle. If the receiver detects an electrical idle while the XIO1100 is in either P0 or P0s power states, the receiver portion of the XIO1100 takes appropriate power saving measures.

### 2.3.3 P1

In the P1 state, selected internal clocks in the XIO1100 will be turned off. RX\_CLK output will stay operational. The MAC moves the XIO1100 to this state only when both transmit and receive channels are idle. The XIO1100 does not indicate successful entry into P1 (by asserting PhyStatus) until RX\_CLK is stable and the operating dc common mode voltage is stable and within specification (in accordance with *PCI Express Base Specification*). P1 is used for the Disabled state, all Detect states, and L1.Idle state of the Link Training and Status State Machine (LTSSM). While in P1 state, the optional P1\_SLEEP input signal can be used to reduce even more power consumption by disabling the RX\_CLK signal. However, the P1\_SLEEP input must not be asserted when the XIO1100 is in any state other than P1 state, and the XIO1100 must not be transitioned out of the P1 state as long as P1\_SLEEP is asserted.

## 2.4 Clock

The RX\_CLK of XIO1100 is derived from the REFCLK input. A 100 MHz differential clock or a 125 MHz single ended clock can be used as the source clock. The frequency selection is determined by CLK\_SEL. If CLK\_SEL is low during /RESET transitioning from a low state to a high state, the source clock at REFCLK+/REFCLK- is a 100 MHz differential clock. If CLK\_SEL is high during /RESET transitioning from a low state to a high state, the source clock at REFCLK+ is a 125 MHz single ended clock. In this case, REFCLK- needs to be tied to VSS.

**Table 2–1. Clock Selection**

	RX_CLK
CLK_SEL = 0	100 MHz differential clock
CLK_SEL = 1	125 MHz single ended clock

## 2.5 Reset

When the MAC resets the XIO1100 (initial power on), the MAC must hold the XIO1100 in reset until power and REFCLK to the XIO1100 are stable. The XIO1100 signals that RX\_CLK is valid (RX\_CLK has been running at its operational frequency for at least one clock), and the XIO1100 is in the specified power state by the de-assertion of PhyStatus. While Reset# is asserted, the MAC must have TxDetectRx/Loopback de-asserted, TxEleIdle asserted, TxCompliance de-asserted, RxPolarity de-asserted, and PowerDown = P1.

## 2.6 Receiver Detection

While in the P1 power state, XIO1100 can be instructed to perform a receiver detection operation to determine if there is a receiver at the other end of the link. The MAC requests XIO1100 to do a receiver detect sequence by asserting TXDETECTRX/LOOPBACK high. Upon completion of the receiver detection operation, the XIO1100 asserts PHY\_STATUS high for one RX\_CLK cycle. While PHY\_STATUS is high, XIO1100 drives the proper receiver status code onto the RX\_STATUS[2:0] signals according to Table 2–2. After the receiver detection has completed (as signaled by the assertion of PhyStatus), the MAC must de-assert TxDetectRx/Loopback before initiating another receiver detection or a power state transition.

**Table 2–2. RX\_STATUS Loopback Detection Code**

RX_STATUS[2:0]	RECEIVER STATUS
000	Receiver not present
011	Receiver present

NOTE: TX\_DET\_LOOPBACK must remain asserted until XIO1100 asserts the PHY\_STATUS.

## 2.7 Receiver Clock Tolerance Compensation

The XIO1100 receiver contains an elastic buffer that compensates for differences in frequencies between bit rates at the two ends of a link. The elastic buffer is capable of holding at least seven symbols to tolerate worst-case differences (600ppm) in frequency and worst-case intervals between SKP ordered-sets, where an SKP order-set is a set of symbols transmitted as a group. The first symbol of a SKP ordered-set is a COM (0xBC) and is followed by three SKP (0x1C) symbols. The purpose of SKP ordered-sets is to allow the receiving device (in this case, XIO1100) to adjust the data stream that is being received to prevent the elastic buffer from either overflowing or underflowing due to any differences between the clocking frequencies of the transmitting device and the receiving device. The XIO1100 monitors the data stream received at the RXP/RXN differential pair for SKP ordered-sets.

When the XIO1100 detects that an SKP ordered-set is being received, it either adds or removes SKP symbols from the data stream, depending on the current state of the elastic buffer. If the elastic buffer is in danger of underflowing, SKP symbols are added to the ordered-set before it is loaded into the buffer. If the elastic buffer is in danger of overflowing, SKP symbols are removed from the ordered-set before it is loaded into the buffer.

When the XIO1100 detects a SKP ordered-set, the XIO1100 asserts an Add SKP code (001b) on the RX\_STATUS[2:0] bus in the same RX\_CLK cycle that it asserts the COM (0xBC) symbol on the RX\_DATA[15:0] bus, if it is adding a SKP symbol to the data stream. In the case of removing an SKP symbol, the XIO1100 asserts the Remove SKP code (010b) to the RX\_STATUS[2:0] when the COM symbol is asserted.

## 2.8 Error Detection

If a detectable receive error occurs, the appropriate error code is asserted on the RX\_STATUS[2:0] pins for one RX\_CLK cycle as close as possible to the point in the data stream where the error occurred. There are four error conditions that can be encoded on the RXSTATUS signals. If more than one error happens to occur on a received byte (or set of bytes transferred across a 16-bit interface), the errors are signaled with the following priority:

- 8B/10B decode error
- Elastic buffer overflow
- Elastic buffer underflow
- Disparity error

If an error occurs during a SKP ordered-set, such that the error code and the SKP code occur concurrently, the error code has priority over the SKP code.

### 2.8.1 8B/10B Decode Error

When XIO1100 detects an 8B/10B decode error, it asserts an EDB (0xFE) symbol in the data on the RX\_DATA[15:0] where the bad byte occurred (only the erroneous byte is replaced with the EDB symbol; the other byte is still valid data). In the same RX\_CLK clock cycle that the EDB symbol is asserted on the RX\_DATA[15:0] bus, the 8B/10B decode error code (100b) is asserted on the RX\_STATUS[2:0] bus. Since the 8B/10B decoding error has priority over all other receive error codes, it could mask out a disparity error occurring on the other byte of data being clocked onto the RX\_DATA[15:0] with the EDB symbol.

### 2.8.2 Elastic Buffer Overflow Error

When the elastic buffer overflows, data is lost during reception. XIO1100 generates an elastic buffer overflow error when this occurs. The elastic buffer overflow error code (101b) is asserted on the RX\_STATUS[2:0] on the RX\_CLK clock cycle that the omitted data would have been asserted. The remaining data asserted on the RX\_DATA[15:0] bus is still valid data, but the elastic buffer overflow error code on the RX\_STATUS[2:0] just marks a discontinuity point in the data stream being received.

### 2.8.3 Elastic Buffer Underflow Error

When the elastic buffer underflows, EDB (0xFE) symbols are inserted into the data stream on the RX\_DATA[15:0] bus to fill the holes created by the gaps between valid data. For every RX\_CLK clock cycle, an EDB symbol is asserted on the RX\_DATA[15:0] bus, and an elastic buffer underflow error code (111b) is asserted on the RX\_STATUS[2:0] bus.

### 2.8.4 Disparity Error

When the XIO1100 detects a disparity error, it asserts a disparity error code (111b) on the RX\_STATUS[2:0] bus in the same RX\_CLK clock cycle that it asserts the erroneous data on the RX\_DATA[15:0] bus. However, it is not possible to discern which byte had the disparity error.

## 2.9 Loopback

The XIO1100 begins a loopback operation when the MAC asserts TX\_DET\_LOOPBACK while holding TX\_ELECIDLE de-asserted. The XIO1100 stops transmitting data to the TXP/TXN signaling pair from the TI-PIPE interface and begins transmitting the data received at the RXP/RXN signaling pair on the TXP/TXN signaling pair. This data is not routed through the 8B/10B coding/encoding paths. While in the loopback operation, the received data is still sent to the RXDATA[15:0] bus of the TI-PIPE interface. The data sent to the RXDATA[15:0] bus is routed through the 10B/8B decoder. The XIO1100 terminates the loopback operation and returns to transmitting TXDATA[15:0] over the TXP/TXN signaling pair when the TX\_DET\_LOOPBACK signal is de-asserted.

## 2.10 Electrical Idle

The XIO1100 expects the MAC to issue the required COM (K28.5) symbol and the required number of IDL symbols (K28.3) on TXDATA[7:0] before asserting the TX\_ELECTRICAL signal. The XIO1100 meets the requirements of the Electrical Requirements of a PCI Express PHY (for these requirements, see Section 4.3.1.9, Electrical Idle, and Table B-2 in Appendix B of *PCI Express Base Specification Revision 1.1*).

## 2.11 Polarity Inversion

Polarity inversion can happen in many places in the receive chain, including somewhere in the serial path, as symbols are placed into the elastic buffer or as symbols are removed from the elastic buffer. The XIO1100 inverts the data received on the RXP/RXN signaling pair when RxPolarity is asserted. The inverted data will begin showing up on the RXDATA within 20 RX\_CLKS of when RxPolarity is asserted.

## 2.12 Setting Negative Parity

To set the running disparity to negative, TxCompliance is asserted for one clock cycle that matches with the data that is to be transmitted with negative disparity.

## 2.13 Terminal Assignments

The XIO1100 is packaged in a 100-pin GGB BGA package. See Section 6 for GGB-package terminal diagram.

Table 2–3 lists the terminal assignments in terminal-number order with corresponding signal names for the GGB package.

Table 2–4 lists the terminal assignments arranged in alphanumerical order by signal name with corresponding terminal numbers for the GGB package.

**Table 2–3. 100-pin GGB Signal Name Sorted by Terminal Number**

GGB NUMBER	SIGNAL NAME	GGB NUMBER	SIGNAL NAME	GGB NUMBER	SIGNAL NAME	GGB NUMBER	SIGNAL NAME
A3	RX_DATA8	C9	RESERVED	G11	VSSA	L6	CLK_SEL
A4	RX_DATA9	C10	VSSA	G12	TXP	L7	VDD_IO
A5	RX_DATA11	C12	RXN	G13	TXN	L8	VSS
A6	RX_DATA13	C13	RXP	H1	TX_DATA13	L9	POWERDOWN1
A7	RX_DATA15	D1	RX_DATA4	H2	TX_DATA14	L10	DDR_EN
A8	RX_DATAK0	D2	RX_DATA5	H3	RX_VALID	L12	VDD_15_COMB
A9	RESERVED	D3	VSS	H11	VDD_33_COMB	L13	VDD_33_COM_IO
A10	RESERVED	D11	VDDA_33	H12	VDDA_15	M3	TX_DATA6
A11	REFCLK-	D12	VSSA	H13	VDDA_15	M4	TX_DATA5
B3	RX_ELECIDLE	D13	VSSA	J1	TX_DATA11	M5	TX_DATA3
B4	RX_DATA10	E1	RX_DATA2	J2	TX_DATA12	M6	TX_DATA1
B5	RX_DATA12	E2	RX_DATA3	J3	VSS	M7	TX_DATAK1
B6	RX_DATA14	E3	RX_STATUS0	J11	VSS	M8	TX_CLK
B7	RX_DATAK1	E11	VDDA_15	J12	VDDA_33	M9	POWERDOWN0
B8	RX_CLK	E12	VSSA	J13	VDDA_33	M10	P1_SLEEP
B9	RESERVED	E13	VDD_15	K1	TX_DATA9	M11	VREG_PD
B10	RESERVED	F1	RX_DATA0	K2	TX_DATA10	N3	TX_DATA7
B11	REFCLK+	F2	RX_DATA1	K3	VDD_IO	N4	TX_DATA4
C1	RX_DATA7	F3	VDD_IO	K11	VSSA	N5	TX_DATA2
C2	RX_DATA6	F11	VDD_15	K12	R0	N6	TX_DATA0
C4	VSS	F12	VSS	K13	R1	N7	TX_DATAK0
C5	VDD_IO	F13	VSSA	L1	TX_DATA8	N8	TXCOMPLIANCE
C6	RX_POLARITY	G1	RX_STATUS1	L2	VSS	N9	TXELECIDLE
C7	VDD_15_CORE	G2	TX_DATA15	L4	VDD_15_CORE	N10	PHY_STATUS
C8	VSS	G3	RX_STATUS2	L5	TXDETECTRX/L OOPBACK	N11	RESETN

Table 2–4. 100-pin GGB Signal Name Sorted Alphabetically

SIGNAL NAME	GGB NUMBER	SIGNAL NAME	GGB NUMBER	SIGNAL NAME	GGB NUMBER	SIGNAL NAME	GGB NUMBER
CLK_SEL	L6	RX_DATA8	A3	TX_DATA6	M3	VDD_IO	F3
P1_SLEEP	M10	RX_DATA9	A4	TX_DATA7	N3	VDD_IO	K3
DDR_EN	L10	RX_DATA10	B4	TX_DATA8	L1	VDD_IO	L7
PHY_STATUS	N10	RX_DATA11	A5	TX_DATA9	K1	VDD_IO	C5
POWERDOWN0	M9	RX_DATA12	B5	TX_DATA10	K2	VDDA_15	H12
POWERDOWN1	L9	RX_DATA13	A6	TX_DATA11	J1	VDDA_15	E11
R0	K12	RX_DATA14	B6	TX_DATA12	J2	VDDA_15	H13
R1	K13	RX_DATA15	A7	TX_DATA13	H1	VDDA_33	J13
REFCLK-	A11	RX_DATAK0	A8	TX_DATA14	H2	VDDA_33	D11
REFCLK+	B11	RX_DATAK1	B7	TX_DATA15	G2	VREG_PD	M11
RESERVED	B9	RX_ELECIDLE	B3	TX_DATAK0	N7	VSS	D3
RESERVED	A10	RX_POLARITY	C6	TX_DATAK1	M7	VSS	J3
RESERVED	B10	RX_STATUS0	E3	TXCOMPLIANCE	N8	VSS	L2
RESERVED	A9	RX_STATUS1	G1	TXDETECTRX/ LOOPBACK	L5	VSS	L8
RESERVED	C9	RX_STATUS2	G3	TXELECIDLE	N9	VSS	J11
/RESET	N11	RX_VALID	H3	TXN	G13	VSS	F12
RX_CLK	B8	RXN	C12	TXP	G12	VSS	C8
RX_DATA0	F1	RXP	C13	VDD_15	F11	VSS	C4
RX_DATA1	F2	TX_CLK	M8	VDD_15	E13	VSSA	K11
RX_DATA2	E1	TX_DATA0	N6	VDD_15_COMB	L12	VSSA	G11
RX_DATA3	E2	TX_DATA1	M6	VDD_15_CORE	L4	VSSA	F13
RX_DATA4	D1	TX_DATA2	N5	VDD_15_CORE	C7	VSSA	E12
RX_DATA5	D2	TX_DATA3	M5	VDDA_33	J12	VSSA	D13
RX_DATA6	C2	TX_DATA4	N4	VDD_33_COM_IO	L13	VSSA	D12
RX_DATA7	C1	TX_DATA5	M4	VDD_33_COMB	H11	VSSA	C10

## 2.14 Terminal Descriptions

Table 2–5 describes the XIO1100 terminals. The terminals are grouped by functionality.

**Table 2–5. XIO1100 Terminals**

TERMINAL		I/O	DESCRIPTION
NAME	NO.		
<b>PIPE INTERFACE</b>			
/RESET	N11	I	Reset the device. This signal is active low and asynchronous.
POWERDOWN[1:0]	L9, M9	I	Power State Control: Value: Description 00: P0, normal operation (used for all Polling, Configuration, Recovery, Loop-back, and Hot-Reset states, and the L0 state of the LTSSM) 01: P0s, low recovery time latency, power-saving state (used for the TX_L0s.idle state of the LTSSM) 10: P1, longer recovery time (64µs max) latency, lower power state (used for the disabled state, all detect states, and the L1.idle state of the LTSSM)
PHY_STATUS	N10	O	Used to communicate completion of several PHY functions, including power management state transitions and receiver detection
TX_CLK	M8	I	Synchronous input clock for TX_DATA[15:0] and TX_DATAK[1:0] inputs If the DDR_EN signal is low during /RESET transitioning from a low state to a high state, TX_CLK is a SDR clock and TX_DATA[15:0] and TX_DATAK[1:0] are latched on the rising edge of TX_CLK. If the DDR_EN signal is high during /RESET transitioning from a low state to a high state, TX_CLK is a DDR clock and TX_DATA[7:0] and TX_DATAK[0] are latched on both the rising and the falling edge of TX_CLK. TX_DATA[15:8] and TX_DATAK[1] are not used.
TX_DATA[15:0]	G2, H2, H1, J2, J1, K2, K1, L1, N3, M3, M4, N4, M5, N5, M6, N6	I	Parallel Data Transmit Bus If the DDR_EN signal is low during /RESET transitioning from a low state to a high state, TX_DATA[15:0] is latched off the bus on the rising edge of TX_CLK. TX_DATA[7:0] represents the first symbol and TX_DATA[15:8] represents the second symbol to be transmitted over the TXN and TXP differential signal pair. If the DDR_EN signal is high during /RESET transitioning from a low state to a high state, TX_DATA[7:0] is latched off the bus on both edges of the TX_CLK. TX_DATA[15:8] is not used and should be grounded. The data on TX_DATA[7:0] during the rising edge of the clock represents the first symbol and data on TX_DATA[7:0] during the falling edge of the clock represents the second symbol to be transmitted over the TXN and TXP differential signal pair.
TX_DATAK[1:0]	M7, N7	I	Data/Control for the Parallel Data Transmit Bus If the DDR_EN signal is low during /RESET transitioning from a low state to a high state, TX_DATAK[0] corresponds to the TX_DATA[7:0] and TX_DATAK[1] to TX_DATA[15:8]. If the DDR_EN signal is high during /RESET transitioning from a low state to a high state, the state of TX_DATAK[0] corresponds to the data on the TX_DATA[7:0] bus during the same phase of the clock. TX_DATAK[1] is not used and should be grounded. A value of zero indicates that the corresponding TXDATA bits contain data information; a value of one indicates that the corresponding TXDATA bits contain a control byte.

NOTE: The TI-PIPE interface can operate at either 1.5 V or 1.8 V, depending on the voltage level of V<sub>DD\_IO</sub>. If V<sub>DD\_IO</sub> is 1.5 V, the TI-PIPE interface operates at 1.5 V level. If V<sub>DD\_IO</sub> is 1.8 V, the TI-PIPE interface operates at 1.8 V level.

Table 2–5. XIO1100 Terminals (Continued)

TERMINAL		I/O	DESCRIPTION
TX_ELECIDLE	N9	I	Forces TXN/TXP outputs to electrical idle. When de-asserting low while in P0 state (POWERDOWN[1:0] = 00), indicates that valid data is on the TXDATA bus and that this data should be transmitted. When asserted high while in P0s state (POWERDOWN[1:0] = 01), always asserted for P0s state. When asserted high while in P1 state (POWERDOWN[1:0] = 10), always asserted for P1 state.
TX_COMPLIANCE	N8	I	Transmit Compliance Pattern When asserted high, the XIO1100 sets the running disparity to negativity. Used when transmitting the compliance pattern.
TX_DET_LOOPBACK	L5	I	Begin Receive Detect/Begin Loop-Back Input to device to either begin a receive detect operation or enter loop-back mode.
RX_CLK	B8	O	Synchronous Output Clock for RX_DATA[15:0] and RX_DATAK[1:0] outputs If the DDR_EN signal is low during /RESET transitioning from a low state to a high state, RX_CLK is a SDR clock, and RX_DATA[15:0] and RX_DATAK[1:0] are latched on the rising edge of RX_CLK. If the DDR_EN signal is high during /RESET transitioning from a low state to a high state, RX_CLK is a DDR clock and RX_DATA[7:0] and RX_DATAK[0] are latched on both the rising and falling edge of the RX_CLK. RX_DATA[15:8] and RX_DATAK[1] are not used. RX_CLK is also used as the internal PCLK for the XIO1100.
RX_DATA[15:0]	A7, B6, A6, B5, A5, B4, A4, A3, C1, C2, D2, D1, E2, E1, F2, F1	O	Parallel Data Receive Bus If the DDR_EN signal is low during /RESET transitioning from a low state to a high state, RX_DATA[15:0] is latched on the rising edge of the RX_CLK. RX_DATA[7:0] represents the first symbol received, and RX_DATA[15:8] represents the second symbol received from the RXN and RXP differential signal pair. If the DDR_EN signal is high during /RESET transitioning from a low state to a high state, RX_DATA[7:0] is latched on both the rising edge and falling edge of the RX_CLK. The data on RX_DATA[7:0] during the rising edge of the RX_CLK represents the first symbol received, and the data on RX_DATA[7:0] during the falling edge of the RX_CLK represents the second symbol received from the RXN and RXP differential signal pair. RX_DATA[15:8] is not used.
RX_DATAK[1:0]	B7, A8	O	Data/Control for the parallel data receive bus If the DDR_EN signal is low during /RESET transitioning from a low state to a high state, the state of RX_DATAK[0] corresponds to RX_DATA[7:0], and RX_DATAK[1] corresponds to RX_DATA[15:8]. If the DDR_EN signal is high during /RESET transitioning from a low state to a high state, the state of RX_DATA[0] corresponds to the data on RX_DATA[7:0] during the same phase of the clock. RX_DATAK[1] is not used. A value of zero indicates that the corresponding RXDATA bits contain data information. A value of one indicates that the corresponding RXDATA bits contain a control byte.

NOTE: The TI-PIPE interface can operate at either 1.5 V or 1.8 V, depending on the voltage level of  $V_{DD\_IO}$ . If  $V_{DD\_IO}$  is 1.5 V, the TI-PIPE interface operates at 1.5 V level. If  $V_{DD\_IO}$  is 1.8 V, the TI-PIPE interface operates at 1.8 V level.

Table 2–5. XIO1100 Terminals (Continued)

TERMINAL		I/O	DESCRIPTION
RX_STATUS[2:0]	G3, G1, E3	O	Encodes receiver status and error codes for the received data stream and receive detection, as follows: Value: Description 000: Received data ok 001: 1 SKP added 010: 1 SKP removed 011: Receiver detected 100: 8B/10B decode error 101: Elastic buffer overflow 110: Elastic buffer underflow 111: Receive disparity error
RX_VALID	H3	O	Indicates symbol lock and valid data on RX_DATA[15:0] and RX_DATAK[1:0]
RX_POLARITY	C6	I	Instructs the XIO1100 to perform polarity inversion on the RXN and RXP differential signal pair. Asserting a high on this signal instructs the XIO1100 to perform the polarity inversion.
RX_ELECIDLE	B3	O	Indicates receiver detection of an electrical idle of the RXP and RXN signal pair. This is an asynchronous signal.
<b>REFERENCE CLOCK PIN</b>			
REFCLK+ REFCLK–	B11 A11	I	The positive and negative terminals for the input reference clock. If CLK_SEL is low during /RESET transitioning from low to high, a 100 MHz clock source has to be applied to REFCLK+ and REFCLK–. If CLK_SEL is high during /RESET transitioning from low to high, a 125 MHz clock source has to be applied to REFCLK+. REFCLK– is not used and should be grounded.
R0 R1	K12 K13	I	Terminals for a 14.56KΩ 1% resistors (recommended 5.90K and 8.66K resistors in series)
<b>TRANSMIT AND RECEIVE PIN</b>			
TXP	G12	O	PCI express link differential pair TX positive terminal
TXN	G13	O	PCI express link differential pair TX negative terminal
RXP	C13	I	PCI express link differential pair RX positive terminal. The XIO1100 has integrated 50-Ω termination resistor to VSS on the RXP terminal, eliminating the need for external components.
RXN	C12	I	PCI express link differential pair RX negative terminal. The XIO1100 has integrated 50-Ω termination resistor to VSS on the RXN terminal, eliminating the need for external components.
<b>MISC</b>			
P1_SLEEP	M10	I	P1 low-power enable. This input, when asserted high, enables a low-power mode when the XIO1100 enters the P1 state. If the input is asserted when the power-down state is P1 (POWERDOWN[1:0] = 10), the device enters a low-power mode. In this mode, the PLL is disabled and the RX_CLK is unavailable. The P1_SLEEP input must not be asserted when the XIO1100 is in any state other than P1 state and the XIO1100 must not be transitioned out of the P1 state as long as P1_SLEEP is asserted.

NOTE: The TI–PIPE interface can operate at either 1.5 V or 1.8 V, depending on the voltage level of V<sub>DD\_IO</sub>. If V<sub>DD\_IO</sub> is 1.5 V, the TI–PIPE interface operates at 1.5 V level. If V<sub>DD\_IO</sub> is 1.8 V, the TI–PIPE interface operates at 1.8 V level.

Table 2–5. XIO1100 Terminals (Continued)

TERMINAL		I/O	DESCRIPTION
CLK_SEL	L6	I	<p>Clock Select</p> <p>This input, when asserted low during /RESET transitioning from low to high, selects the 100 MHz differential clock source. A 100MHz clock source has to be applied to REFCLK+ and REFCLK–.</p> <p>This input, when asserted high during /RESET transitioning to high, selects the 125 MHz single ended clock source. A 125 MHz clock source has to be applied to REFCLK+. REFCLK– has to be connected to VSS.</p>
VREG_PD	M11	I	This pin must be pulled to GND during normal operation.
DDR_EN	L10	I	<p>DDR_EN</p> <p>This input, when asserted high during /RESET transitioning to low state to high state, defines the TI–PIPE interface to be a 8–bit DDR interface; otherwise, it is an 16-bit SDR interface.</p> <p>Value: Description            1: DDR_EN is an 8–bit DDR interface            0: DDR_EN is a 16–bit SDR interface</p>
<b>RESERVED</b>			
RESERVED	B9		RESERVED
RESERVED	A10		RESERVED
RESERVED	B10		RESERVED
RESERVED	A9		RESERVED
RESERVED	C9		RESERVED. This pin needs to be pulled to GND during normal operation.
<b>POWER SUPPLY TERMINALS</b>			
VDD_15	E13, F11	PWR	1.5–V digital power supply.
VDD_15_CORE	C7, L4	PWR	1.5–V core voltage.
VDDA_15	E11, H12, H13	PWR	1.5–V analog power supply.
VDD_15_COMB	L12	PWR	1.5–V main power output. It should be connected to a filter network of 0.01μF, 1μF, and 1000pF capacitors.
VDDA_33	D11, J12, J13	PWR	3.3–V analog power supply.
VDD_33_COMB	H11	PWR	3.3–V main output. It should be connected to a filter network of 0.01μF, 1μF, and 1000pF capacitors.
VDD_33_COMB_IO	L13	PWR	3.3–V I/O output. It should be connected to a filter network of 0.01μF, 1μF, and 1000pF capacitors.
VDD_IO	C5, F3, K3, L7	PWR	Power supply for digital I/O. Can be either 1.5 V or 1.8 V depending on desired signaling level.
VSS	D3, J3, L2, L8, J11, F12, C4, C8	GND	Digital ground.
VSSA	K11, G11, F13, E12, D13, D12, C10	GND	Analog ground.

NOTE: The TI–PIPE interface can operate at either 1.5 V or 1.8 V, depending on the voltage level of V<sub>DD\_IO</sub>. If V<sub>DD\_IO</sub> is 1.5 V, the TI–PIPE interface operates at 1.5 V level. If V<sub>DD\_IO</sub> is 1.8 V, the TI–PIPE interface operates at 1.8 V level.

### 3 Electrical Characteristics

#### 3.1 Absolute Maximum Ratings†

Supply voltage range:	3.3 V Supply	.....	-0.5 V to 3.6 V
	1.8 V Supply	.....	-0.5 V to 1.95 V
	1.5 V Supply	.....	-0.5 V to 1.65 V
Input voltage range,	V <sub>I</sub> : PCI Express (RX)	.....	-0.6 V to 0.6 V
	V <sub>I</sub> : PCI Express REFCLK (single-ended)	.....	-0.5 V to V <sub>DDA_33</sub> + 0.5 V
	V <sub>I</sub> : PCI Express REFCLK (differential)	.....	-0.5 V to V <sub>DD_15</sub> + 0.5 V
Input clamp current, (V <sub>I</sub> < 0 or V <sub>I</sub> > V <sub>DD</sub> ) (see Note 1)			±20 mA
Output clamp current, (V <sub>O</sub> < 0 or V <sub>O</sub> > V <sub>DD</sub> ) (see Note 2)			±20 mA
Human body model (HBM) ESD performance			1500 V
Charged device model (CDM) ESD performance			500 V
Storage temperature range, T <sub>stg</sub>			-65°C to 150°C

† Stresses beyond those listed under absolute maximum ratings may cause permanent damage to the device. These are stress ratings only, and functional operation of the device at these or any other conditions beyond those indicated under recommended operating conditions is not implied. Exposure to absolute-maximum-rated conditions for extended periods may affect device reliability.

- NOTES: 1. Applies for external input and bidirectional buffers. V<sub>I</sub> < 0 or V<sub>I</sub> > V<sub>DD</sub>.  
 2. Applies to external output and bidirectional buffers. V<sub>O</sub> < 0 or V<sub>O</sub> > V<sub>DD</sub>.

#### 3.1.1 Current Consumption

MODE	TX	RX	VDDIO	VDD15	VDD33	UNITS
L0	on	on	89	102	5.4	mA
L0s	idle	on	89	81	1.3	mA
	on	idle	66	93	4.3	mA
L1	idle	idle	66	72	1.3	mA
	on	idle	66	94	4.3	mA
	L1_sleep		75	10	1.3	mA

#### 3.2 Recommended Operating Conditions

		OPERATION	MIN	NOM	MAX	UNIT
V <sub>DD_15</sub>	Supply voltage	1.5 V	1.35	1.5	1.65	V
V <sub>DDA_15</sub>						
V <sub>DD_15_CORE</sub>						
V <sub>DDA_33</sub>	Supply voltage	3.3 V	3	3.3	3.6	V
V <sub>DD_IO</sub> (1.5 V)	Supply voltage (I/O)	1.5V	1.35	1.5	1.65	V
V <sub>DD_IO</sub> (1.8 V)	Supply voltage (I/O)	1.8V	1.65	1.8	1.95	V
T <sub>A</sub>	Operating ambient temperature range		0	25	70	°C
T <sub>J</sub>	Virtual junction temperature (Note 3)		0	25	115	°C

NOTES: 3. The junction temperature reflects simulated conditions. The customer is responsible for verifying junction temperature.

NOTE: The TI-PIPE interface can operate either at 1.5 V or 1.8 V, depending on the voltage level of V<sub>DD\_IO</sub>. If V<sub>DD\_IO</sub> is 1.5 V, the TI-PIPE interface operates at 1.5 V level. If V<sub>DD\_IO</sub> is 1.8 V, the TI-PIPE interface operates at 1.8 V level.

### 3.3 PCI Express Differential Transmitter Output Ranges

PARAMETER	TERMINALS	MIN	NOM	MAX	UNIT	COMMENTS
UI Unit interval	TXP, TXN	399.88	400	400.12	ps	Each UI is 400 ps $\pm$ 300 ppm. UI does not account for SSC-dictated variations. See Note 4.
$V_{TX-DIFFp-p}$ Differential peak-to-peak output voltage	TXP, TXN	0.8		1.2	V	$V_{TX-DIFFp-p} = 2 *  V_{TXP} - V_{TXN} $ See Note 5.
$V_{TX-DE-RATIO}$ De-emphasized differential output voltage (ratio)	TXP, TXN	-3.0	-3.5	-4.0	dB	This is the ratio of the $V_{TX-DIFFp-p}$ of the second and following bits after a transition divided by the $V_{TX-DIFFp-p}$ of the first bit after a transition. See Note 5.
$T_{TX-EYE}$ Minimum TX eye width	TXP, TXN	0.75			UI	The maximum transmitter jitter can be derived as $T_{TXMAX-JITTER} = 1 - T_{TX-EYE} = 0.3$ UI See Notes 5 and 6.
$T_{TX-EYE-MEDIAN-to-MAX-JITTER}$ Maximum time between the jitter median and maximum deviation from the median	TXP, TXN			0.15	UI	Jitter is defined as the measurement variation of the crossing points ( $V_{TX-DIFFp-p} = 0$ V) in relation to recovered TX UI. A recovered TX UI is calculated over 3500 consecutive UIs of sample data. Jitter is measured using all edges of the 250 consecutive UIs in the center of the 3500 UIs used for calculating the TX UI. See Notes 5 and 6.
$T_{TX-RISE}$ , $T_{TX-FALL}$ P/N TX output rise/fall time	TXP, TXN	0.125			UI	See Notes 5 and 8.
$V_{TX-CM-ACp}$ RMS ac peak common mode output voltage	TXP, TXN			20	mV	$V_{TX-CM-ACp} = \text{RMS}( V_{TXP} + V_{TXN} /2 - V_{TX-CM-DC})$ $V_{TX-CM-DC} = DC_{(avg)}$ of $ V_{TXP} + V_{TXN} /2$ See Note 5.
$V_{TX-CM-DC-ACTIVE-IDLE-DELTA}$ Absolute delta of dc common mode voltage during L0 and electrical idle.	TXP, TXN	0		100	mV	$ V_{TX-CM-DC} - V_{TX-CM-Idle-DC}  \leq 100$ mV $V_{TX-CM-DC} = DC_{(avg)}$ of $ V_{TXP} + V_{TXN} /2$ [during L0] $V_{TX-CM-Idle-DC} = DC_{(avg)}$ of $ V_{TXP} + V_{TXN} /2$ [during electrical idle] See Note 5.
$V_{TX-CM-DC-LINE-DELTA}$ Absolute delta of dc common mode voltage between P and N	TXP, TXN	0		25	mV	$ V_{TXP-CM-DC} - V_{TXN-CM-DC}  \leq 25$ mV when $V_{TXP-CM-DC} = DC_{(avg)}$ of $ V_{TXP} $ $V_{TXN-CM-DC} = DC_{(avg)}$ of $ V_{TXN} $ See Note 5.

- NOTES:
- No test load is necessarily associated with this value.
  - Specified at the measurement point into a timing and voltage compliance test load and measured over any 250 consecutive TX UIs.
  - A  $T_{TX-EYE} = 0.75$  UI provides for a total sum of deterministic and random jitter budget of  $T_{TX-JITTER-MAX} = 0.25$  UI for the transmitter collected over any 250 consecutive TX UIs. The  $T_{TX-EYE-MEDIAN-to-MAX-JITTER}$  specification ensures a jitter distribution in which the median and the maximum deviation from the median is less than half of the total TX jitter budget collected over any 250 consecutive TX UIs. It must be noted that the median is not the same as the mean. The jitter median describes the point in time where the number of jitter points on either side is approximately equal, as opposed to the averaged time value.
  - The transmitter input impedance results in a differential return loss greater than or equal to 12 dB and a common mode return loss greater than or equal to 6 dB over a frequency range of 50 MHz to 1.25 GHz. This input impedance requirement applies to all valid input levels. The reference impedance for return loss measurements is 50  $\Omega$  to ground for both the P and N lines. Note that the use of the series capacitors  $C_{TX}$  is optional for the return loss measurement.
  - Measured between 20% and 80% at transmitter package terminals into a test load for both  $V_{TXP}$  and  $V_{TXN}$

PARAMETER	TERMINALS	MIN	NOM	MAX	UNIT	COMMENTS
$V_{TX-IDLE-DIFFp}$ Electrical idle differential peak output voltage	TXP, TXN	0		20	mV	$V_{TX-IDLE-DIFFp} =  V_{TXP-Idle} - V_{TXN-Idle}  \leq 20$ mV See Note 5.
$V_{TX-RCV-DETECT}$ The amount of voltage change allowed during receiver detection	TXP, TXN			600	mV	The total amount of voltage change that a transmitter can apply to sense whether a low impedance receiver is present.
$V_{TX-DC-CM}$ The TX dc common mode voltage	TXP, TXN	0		3.6	V	The allowed dc common mode voltage under any condition.
$I_{TX-SHORT}$ TX short circuit current limit	TXP, TXN			90	mA	Total current the transmitter can provide when shorted to its ground
$T_{TX-IDLE-MIN}$ Minimum time spent in electrical idle	TXP, TXN	50			UI	Minimum time a transmitter must be in electrical Idle. Utilized by the receiver to start looking for an electrical idle exit after successfully receiving an electrical idle ordered set.
$T_{TX-IDLE-SET-to-IDLE}$ Maximum time to transition to a valid electrical idle after sending an electrical idle ordered set	TXP, TXN			20	UI	After sending an electrical idle ordered set, the transmitter must meet all electrical idle specifications within this time. This is considered a debounce time for the transmitter to meet electrical idle after transitioning from L0.
$T_{TX-IDLE-to-DIFF-DATA}$ Maximum time to transition to valid TX specifications after leaving an electrical idle condition	TXP, TXN			20	UI	Maximum time to meet all TX specifications when transitioning from electrical idle to sending differential data. This is considered a debounce time for the TX to meet all TX specifications after leaving electrical idle.
$RL_{TX-DIFF}$ Differential return loss	TXP, TXN	10			dB	Measured over 50 MHz to 1.25 GHz. See Note 7.
$RL_{TX-CM}$ Common mode return loss	TXP, TXN	6			dB	Measured over 50 MHz to 1.25 GHz. See Note 7.
$Z_{TX-DIFF-DC}$ DC differential TX impedance	TXP, TXN	80	100	120	$\Omega$	TX dc differential mode low impedance

- NOTES:
- No test load is necessarily associated with this value.
  - Specified at the measurement point into a timing and voltage compliance test load and measured over any 250 consecutive TX UIs.
  - A  $T_{TX-EYE} = 0.75$  UI provides for a total sum of deterministic and random jitter budget of  $T_{TX-JITTER-MAX} = 0.25$  UI for the transmitter collected over any 250 consecutive TX UIs. The  $T_{TX-EYE-MEDIAN-to-MAX-JITTER}$  specification ensures a jitter distribution in which the median and the maximum deviation from the median is less than half of the total TX jitter budget collected over any 250 consecutive TX UIs. It must be noted that the median is not the same as the mean. The jitter median describes the point in time where the number of jitter points on either side is approximately equal, as opposed to the averaged time value.
  - The transmitter input impedance results in a differential return loss greater than or equal to 12 dB and a common mode return loss greater than or equal to 6 dB over a frequency range of 50 MHz to 1.25 GHz. This input impedance requirement applies to all valid input levels. The reference impedance for return loss measurements is 50  $\Omega$  to ground for both the P and N lines. Note that the use of the series capacitors  $C_{TX}$  is optional for the return loss measurement.
  - Measured between 20% and 80% at transmitter package terminals into a test load for both  $V_{TXP}$  and  $V_{TXN}$

PARAMETER	TERMINALS	MIN	NOM	MAX	UNIT	COMMENTS
$Z_{TX-DC}$ Transmitter dc impedance	TXP, TXN	40			$\Omega$	Required TXP as well as TXN dc impedance during all states
$C_{TX}$ AC coupling capacitor	TXP, TXN	75		200	nF	All transmitters are ac-coupled and are required on the PWB.

- NOTES:
- No test load is necessarily associated with this value.
  - Specified at the measurement point into a timing and voltage compliance test load and measured over any 250 consecutive TX UIs.
  - A  $T_{TX-EYE} = 0.75$  UI provides for a total sum of deterministic and random jitter budget of  $T_{TX-JITTER-MAX} = 0.25$  UI for the transmitter collected over any 250 consecutive TX UIs. The  $T_{TX-EYE-MEDIAN-to-MAX-JITTER}$  specification ensures a jitter distribution in which the median and the maximum deviation from the median is less than half of the total TX jitter budget collected over any 250 consecutive TX UIs. It must be noted that the median is not the same as the mean. The jitter median describes the point in time where the number of jitter points on either side is approximately equal, as opposed to the averaged time value.
  - The transmitter input impedance results in a differential return loss greater than or equal to 12 dB and a common mode return loss greater than or equal to 6 dB over a frequency range of 50 MHz to 1.25 GHz. This input impedance requirement applies to all valid input levels. The reference impedance for return loss measurements is 50  $\Omega$  to ground for both the P and N lines. Note that the use of the series capacitors  $C_{TX}$  is optional for the return loss measurement.
  - Measured between 20% and 80% at transmitter package terminals into a test load for both  $V_{TXP}$  and  $V_{TXN}$

### 3.4 PCI Express Differential Receiver Input Ranges

PARAMETER	TERMINALS	MIN	NOM	MAX	UNIT	COMMENTS
UI Unit interval	RXP, RXN	399.88	400	400.12	ps	Each UI is 400 ps $\pm$ 300 ppm. UI does not account for SSC-dictated variations. See Note 9.
$V_{RX-DIFFp-p}$ Differential input peak-to-peak voltage	RXP, RXN	0.175		1.200	V	$V_{RX-DIFFp-p} = 2 *  V_{RXP} - V_{RXN} $ See Note 10.
$T_{RX-EYE}$ Minimum receiver eye width	RXP, RXN	0.4			UI	The maximum interconnect media and transmitter jitter that can be tolerated by the receiver is derived as $T_{RX-MAX-JITTER} = 1 - T_{RX-EYE} = 0.6$ UI. See Notes 10 and 11.

- NOTES:
- No test load is necessarily associated with this value.
  - Specified at the measurement point and measured over any 250 consecutive UIs. A test load must be used as the RX device when taking measurements. If the clocks to the RX and TX are not derived from the same reference clock, the TX UI recovered from 3500 consecutive UI is used as a reference for the eye diagram.
  - A  $T_{RX-EYE} = 0.40$  UI provides for a total sum of 0.60 UI deterministic and random jitter budget for the transmitter and interconnect collected any 250 consecutive UIs. The  $T_{RX-EYE-MEDIAN-to-MAX-JITTER}$  specification ensures a jitter distribution in which the median and the maximum deviation from the median is less than half of the total UI jitter budget collected over any 250 consecutive TX UIs. It must be noted that the median is not the same as the mean. The jitter median describes the point in time where the number of jitter points on either side is approximately equal, as opposed to the averaged time value. If the clocks to the RX and TX are not derived from the same reference clock, the TX UI recovered from 3500 consecutive UIs must be used as the reference for the eye diagram.
  - The receiver input impedance results in a differential return loss greater than or equal to 15 dB with the P line biased to 300 mV and the N line biased to -300 mV and a common mode return loss greater than or equal to 6 dB (no bias required) over a frequency range of 50 MHz to 1.25 GHz. This input impedance requirement applies to all valid input levels. The reference impedance for return loss measurements is 50  $\Omega$  to ground for both the P and N line (i.e., as measured by a Vector Network Analyzer with 50- $\Omega$  probes). The use of the series capacitors  $C_{TX}$  is optional for the return loss measurement.
  - Impedance during all link training status state machine (LTSSM) states. When transitioning from a PCI Express reset to the detect state (the initial state of the LTSSM), there is a 5-ms transition time before receiver termination values must be met on the unconfigured lane of a port.
  - The RX dc common mode impedance that exists when no power is present or PCI Express reset is asserted. This helps ensure that the receiver detect circuit does not falsely assume a receiver is powered on when it is not. This term must be measured at 300 mV above the RX ground.

PARAMETER	TERMINALS	MIN	NOM	MAX	UNIT	COMMENTS
$T_{RX-EYE-MEDIAN-to-MAX-JITTER}$ Maximum time between the jitter median and maximum deviation from the median	RXP, RXN			0.3	UI	Jitter is defined as the measurement variation of the crossing points ( $V_{RX-DIFFP-p} = 0\text{ V}$ ) in relation to recovered TX UI. A recovered TX UI is calculated over 3500 consecutive UIs of sample data. Jitter is measured using all edges of the 250 consecutive UIs in the center of the 3500 UIs used for calculating the TX UI. See Notes 10 and 11.
$V_{RX-CM-ACp}$ AC peak common mode input voltage	RXP, RXN			150	mV	$V_{RX-CM-ACp} = \text{RMS}( V_{RXP} + V_{RXN} /2 - V_{RX-CM-DC})$ $V_{RX-CM-DC} = DC_{(avg)} \text{ of }  V_{RXP} + V_{RXN} /2$ See Note 10.
$RL_{RX-DIFF}$ Differential return loss	RXP, RXN	10			dB	Measured over 50 MHz to 1.25 GHz with the P and N lines biased at +300 mV and -300 mV, respectively. See Note 12.
$RL_{RX-CM}$ Common mode return loss	RXP, RXN	6			dB	Measured over 50 MHz to 1.25 GHz with the P and N lines biased at +300 mV and -300 mV, respectively. See Note 12.
$Z_{RX-DIFF-DC}$ DC differential input impedance	RXP, RXN	80	100	120	$\Omega$	RX dc differential mode impedance. See Note 13.
$Z_{RX-DC}$ DC input impedance	RXP, RXN	40	50	60	$\Omega$	Required RXP as well as RXN dc impedance (50 $\Omega$ $\pm$ 20% tolerance). See Notes 10 and 13.
$Z_{RX-HIGH-IMP-DC}$ Powered-down dc input impedance	RXP, RXN	200k			$\Omega$	Required RXP as well as RXN dc impedance when the receiver terminations do not have power. See Note 14.

NOTES: 9. No test load is necessarily associated with this value.

10. Specified at the measurement point and measured over any 250 consecutive UIs. A test load must be used as the RX device when taking measurements. If the clocks to the RX and TX are not derived from the same reference clock, the TX UI recovered from 3500 consecutive UI is used as a reference for the eye diagram.
11. A  $T_{RX-EYE} = 0.40$  UI provides for a total sum of 0.60 UI deterministic and random jitter budget for the transmitter and interconnect collected any 250 consecutive UIs. The  $T_{RX-EYE-MEDIAN-to-MAX-JITTER}$  specification ensures a jitter distribution in which the median and the maximum deviation from the median is less than half of the total UI jitter budget collected over any 250 consecutive TX UIs. It must be noted that the median is not the same as the mean. The jitter median describes the point in time where the number of jitter points on either side is approximately equal, as opposed to the averaged time value. If the clocks to the RX and TX are not derived from the same reference clock, the TX UI recovered from 3500 consecutive UIs must be used as the reference for the eye diagram.
12. The receiver input impedance results in a differential return loss greater than or equal to 15 dB with the P line biased to 300 mV and the N line biased to -300 mV and a common mode return loss greater than or equal to 6 dB (no bias required) over a frequency range of 50 MHz to 1.25 GHz. This input impedance requirement applies to all valid input levels. The reference impedance for return loss measurements is 50  $\Omega$  to ground for both the P and N line (i.e., as measured by a Vector Network Analyzer with 50- $\Omega$  probes). The use of the series capacitors  $C_{TX}$  is optional for the return loss measurement.
13. Impedance during all link training status state machine (LTSSM) states. When transitioning from a PCI Express reset to the detect state (the initial state of the LTSSM), there is a 5-ms transition time before receiver termination values must be met on the unconfigured lane of a port.
14. The RX dc common mode impedance that exists when no power is present or PCI Express reset is asserted. This helps ensure that the receiver detect circuit does not falsely assume a receiver is powered on when it is not. This term must be measured at 300 mV above the RX ground.

PARAMETER	TERMINALS	MIN	NOM	MAX	UNIT	COMMENTS
$V_{RX-IDLE-DET-DIFFp-p}$ Electrical idle detect threshold	RXP, RXN	65		175	mV	$V_{RX-IDLE-DET-DIFFp-p} = 2 *  V_{RXP} - V_{RXN} $ measured at the receiver package terminals
$T_{RX-IDLE-DET-DIFF-ENTER-TIME}$ Unexpected electrical idle enter detect threshold integration time	RXP, RXN			10	ms	An unexpected electrical idle ( $V_{RX-DIFFp-p} < V_{RX-IDLE-DET-DIFFp-p}$ ) must be recognized no longer than $T_{RX-IDLE-DET-DIFF-ENTER-TIME}$ to signal an unexpected idle condition.

- NOTES:
9. No test load is necessarily associated with this value.
  10. Specified at the measurement point and measured over any 250 consecutive UIs. A test load must be used as the RX device when taking measurements. If the clocks to the RX and TX are not derived from the same reference clock, the TX UI recovered from 3500 consecutive UI is used as a reference for the eye diagram.
  11. A  $T_{RX-EYE} = 0.40$  UI provides for a total sum of 0.60 UI deterministic and random jitter budget for the transmitter and interconnect collected any 250 consecutive UIs. The  $T_{RX-EYE-MEDIAN-to-MAX-JITTER}$  specification ensures a jitter distribution in which the median and the maximum deviation from the median is less than half of the total UI jitter budget collected over any 250 consecutive TX UIs. It must be noted that the median is not the same as the mean. The jitter median describes the point in time where the number of jitter points on either side is approximately equal, as opposed to the averaged time value. If the clocks to the RX and TX are not derived from the same reference clock, the TX UI recovered from 3500 consecutive UIs must be used as the reference for the eye diagram.
  12. The receiver input impedance results in a differential return loss greater than or equal to 15 dB with the P line biased to 300 mV and the N line biased to -300 mV and a common mode return loss greater than or equal to 6 dB (no bias required) over a frequency range of 50 MHz to 1.25 GHz. This input impedance requirement applies to all valid input levels. The reference impedance for return loss measurements is 50  $\Omega$  to ground for both the P and N line (i.e., as measured by a Vector Network Analyzer with 50- $\Omega$  probes). The use of the series capacitors  $C_{TX}$  is optional for the return loss measurement.
  13. Impedance during all link training status state machine (LTSSM) states. When transitioning from a PCI Express reset to the detect state (the initial state of the LTSSM), there is a 5-ms transition time before receiver termination values must be met on the unconfigured lane of a port.
  14. The RX dc common mode impedance that exists when no power is present or PCI Express reset is asserted. This helps ensure that the receiver detect circuit does not falsely assume a receiver is powered on when it is not. This term must be measured at 300 mV above the RX ground.

### 3.5 Express Differential Reference Clock Input Ranges

PARAMETER	TERMINALS	MIN	NOM	MAX	UNIT	COMMENTS
$f_{IN-DIFF}$ Differential input frequency	REFCLK+ REFCLK-		100		MHz	The input frequency is 100 MHz + 300 ppm and - 2800 ppm including SSC-dictated variations.
$f_{IN-SE}$ Single-ended input frequency	REFCLK+		125		MHz	The input frequency is 125 MHz + 300 ppm and - 300 ppm.
$V_{RX-DIFFp-p}$ Differential input peak-to-peak voltage	REFCLK+ REFCLK-	0.175		1.200	V	$V_{RX-DIFFp-p} = 2 *  V_{REFCLK+} - V_{REFCLK-} $
$V_{IH-SE}$	REFCLK+	$0.7 V_{DD\_33}$		$V_{DD\_33}$	V	Single-ended, reference clock mode high-level input voltage
$V_{IL-SE}$	REFCLK+	0		$0.3 V_{DD\_33}$	V	Single-ended, reference clock mode low-level input voltage
$V_{RX-CM-ACp}$ AC peak common mode input voltage	REFCLK+ REFCLK-			140	mV	$V_{RX-CM-ACp} = \text{RMS}( V_{REFCLK+} + V_{REFCLK-} /2 - V_{RX-CM-DC})$ $V_{RX-CM-DC} = DC_{(avg)} \text{ of }  V_{REFCLK+} + V_{REFCLK-} /2$
Duty cycle	REFCLK+ REFCLK-	40%		60%		Differential and single-ended waveform input duty cycle
$Z_{RX-DIFF-DC}$ DC differential input impedance	REFCLK+ REFCLK-		20		k $\Omega$	REFCLK+/- dc differential mode impedance
$Z_{RX-DC}$ DC input impedance	REFCLK+ REFCLK-		20		k $\Omega$	REFCLK+ dc single-ended mode impedance

NOTE 15: The XIO1100 is compliant with the defined system jitter models for a PCI-Express reference clock and associated TX/RX link. These system jitter models are described in the *PCI-Express Jitter Modeling*, Revision 1.0RD document. Any usage of the XIO1100 in a system configuration that does not conform to the defined system jitter models requires the system designer to validate the system jitter budgets.

### 3.6 Electrical Characteristics Over Recommended Operating Conditions ( $V_{DD\_IO}$ )

PARAMETER	OPERATION	TEST CONDITIONS	MIN	TYP	MAX	UNIT
$V_{IH}$	High-level input voltage (Note 16)	$V_{DD\_IO}$	$0.7 V_{DD\_IO}$		$V_{DD\_IO}$	V
$V_{IL}$	Low-level input voltage (Note 16)	$V_{DD\_IO}$	0		$0.3 V_{DD\_IO}$	V
$V_I$	Input voltage		0		$V_{DD\_IO}$	V
$V_O$	Output voltage (Note 17)		0		$V_{DD\_IO}$	V
$t_T$	Input transition time ( $t_{rise}$ and $t_{fall}$ )		0		25	ns
$V_{OH}$	High-level output voltage	$V_{DD\_IO}$	$I_{OH} = -8$ mA	$0.8 V_{DD\_IO}$		V
$V_{OL}$	Low-level output voltage	$V_{DD\_IO}$	$I_{OL} = 8$ mA		$0.22 V_{DD\_IO}$	V
$I_{OH}$	High-level output current			-8		mA
$I_{OL}$	Low-level output current			8		mA
$I_{OZ}$	High-impedance, output current (Note 17)	$V_{DD\_IO}$	$V_I = 0$ to $V_{DD\_IO}$		$\pm 20$	$\mu$ A
$I_I$	Input current (Note 18)	$V_{DD\_IO}$	$V_I = 0$ to $V_{DD\_IO}$		$\pm 1$	$\mu$ A

NOTES: 16. Applies to external inputs and bidirectional buffers.

17. Applies to external outputs and bidirectional buffers.

18. Applies to external input buffers.

### 3.7 Implementation-Specific Timing

TIMING	DESCRIPTION	NORM	MAX
Transmit Latency	Time for data moving between the parallel interface and the PCI Express serial lines. Timing is measured from when the data is transferred across the parallel interface (i.e., the rising edge of TX_CLK) and when the first bit of the equivalent 10-bit symbol is transmitted on the Tx+/Tx- serial lines.	29.2 ns	33.2 ns
Receive Latency	Time for data moving between the parallel interface and the PCI Express serial lines. Timing is measured from when the first bit of a 10-bit symbol is available on the Rx+/Rx- serial lines to when the corresponding 8-bit data is transferred across the parallel interface (i.e., the rising edge of RX_CLK).	77.2 ns	93.2 ns
Loopback Enable Latency	Amount of time that the XIO1100 requires to begin looping back receive data. Duration is from when TxDetectRx/Loopback is asserted until the receive data is being transmitted on the serial pins.	25.2 ns	29.2 ns
N_FTS with Common Clock	Number of FTS ordered sets required by the receiver to obtain reliable bit and symbol lock when operating with a common clock.	23	23
N_FTS without Common Clock	Number of FTS ordered sets required by the receiver to obtain reliable bit and symbol lock when operating without a common clock.	255	255
XIO1100 Lock Time	Amount of time required for the XIO1100 receiver to obtain reliable bit and symbol lock after valid TSx ordered-sets are present at the receiver.	2.0 $\mu$ s	4.0 $\mu$ s
P0s to P0 Transitioning Time	Amount of time required for the XIO1100 to return to the P0 state after having been in the P0s state. Time is measured from when the MAC sets the PowerDown signals to P0 until the XIO1100 asserts PhyStatus. The XIO1100 asserts PhyStatus when it is ready to begin data transmission and reception.	28.0 ns	32.0 ns
P1 to P0 Transitioning Time	Amount of time required for the XIO1100 to return to the P0 state after having been in the P1 state. Time is measured from when the MAC sets the PowerDown signals to P0 until the XIO1100 asserts PhyStatus. The XIO1100 asserts PhyStatus when it is ready to begin data transmission and reception.	28.0 ns	32.0 ns
Reset to Ready Time	Timed from when Reset# is de-asserted until the XIO1100 de-asserts PHY_STATUS.	10.0 ns	11.0 ns

## 4 Timing Diagrams

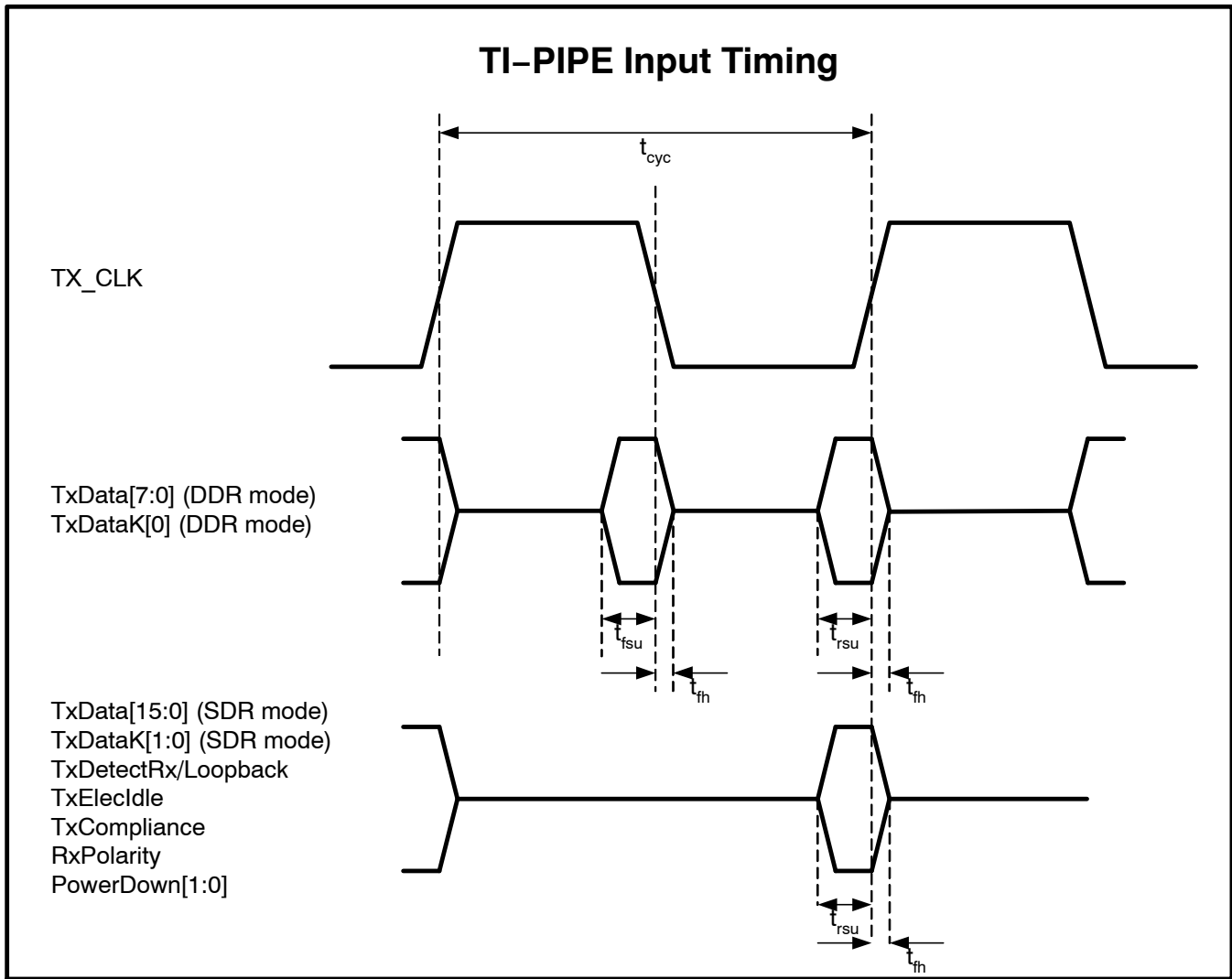

Figure 4-1. TI-PIPE Input Timing

PARAMETER	DESCRIPTION	VALUE
tcyc	Period, TX_CLK	8 ns (TYP)
trsu	Input Setup to TX_CLK rising	1.3 ns (MAX)
trh	Input Hold from TX_CLK rising	0.1 ns (MIN)
tfsu	Input Setup to TX_CLK falling	1.3 ns (MAX)
tfh	Input Hold from TX_CLK falling	0.1 ns (MIN)

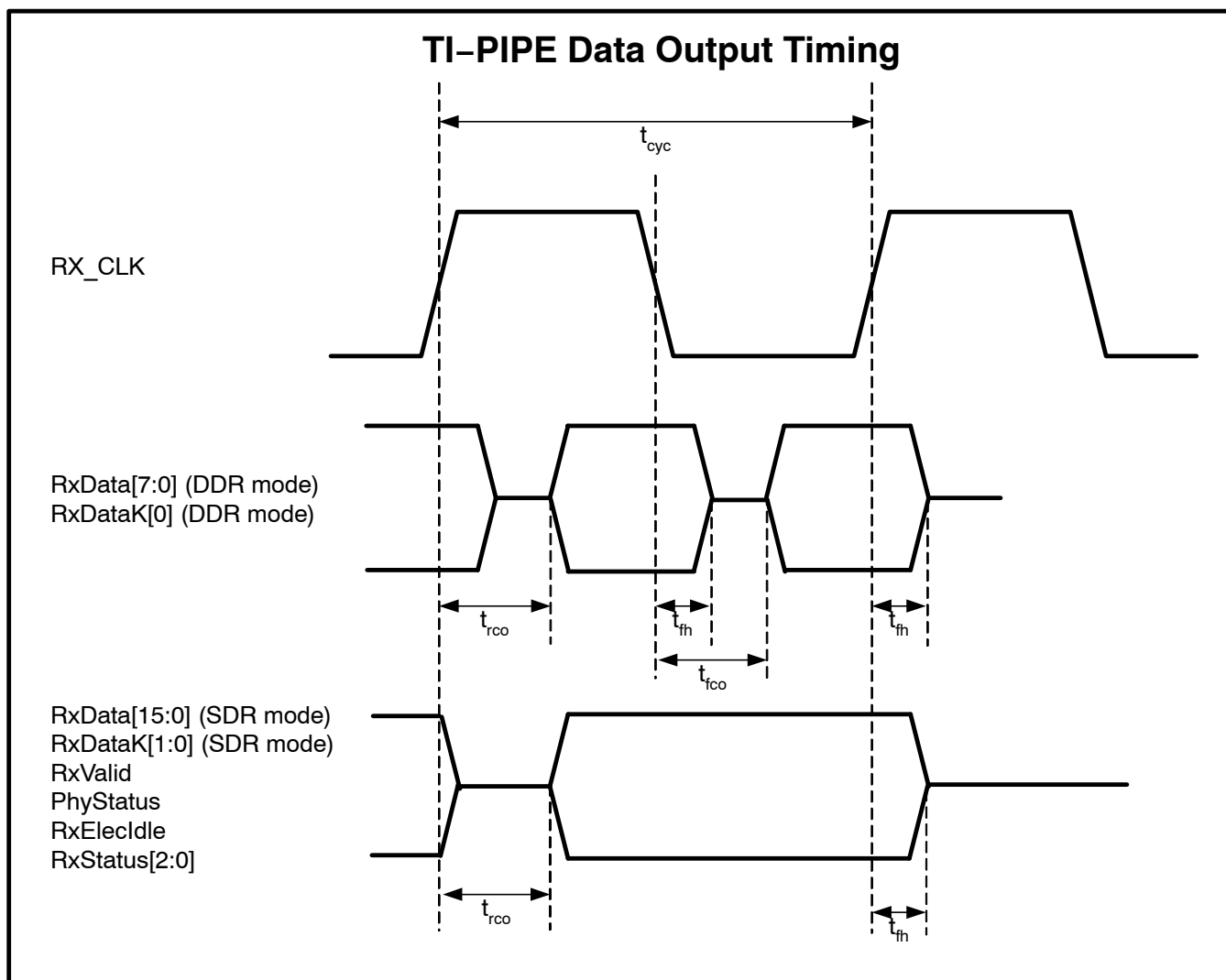

Figure 4-2. TI-PIPE Data Output Timing

PARAMETER	DESCRIPTION	VALUE
$t_{cyc}$	Period, <b>RX_CLK</b>	8.0 ns (TYP)
$t_{rco}$	Clock to output, <b>RX_CLK</b> rising	2.0 ns (MAX)
$t_{rh}$	Output hold, <b>RX_CLK</b> rising	0.7 ns (MIN)
$t_{fco}$	Clock to output, <b>RX_CLK</b> falling	2.0 ns (MAX)
$t_{fh}$	Output hold, <b>RX_CLK</b> falling	0.7 ns (MIN)

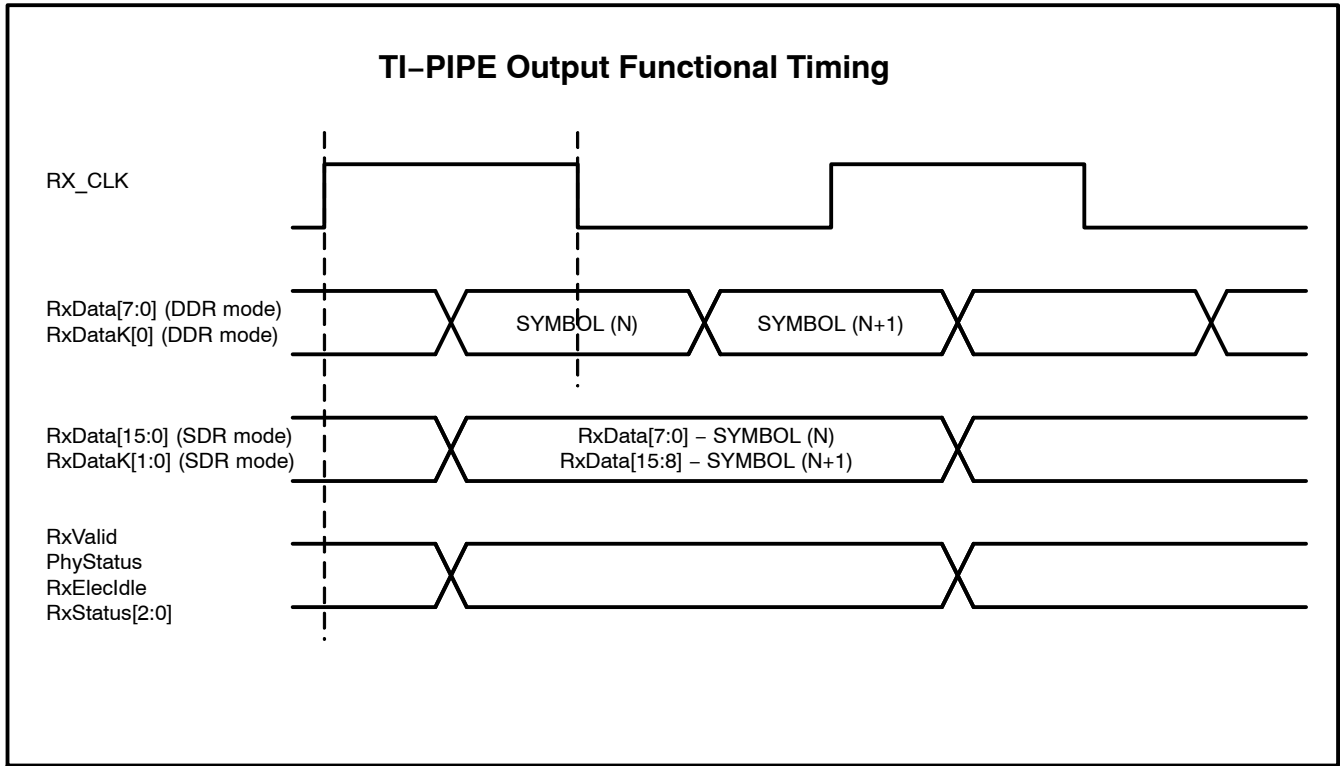

Figure 4-3. TI-PIPE Output Functional Timing

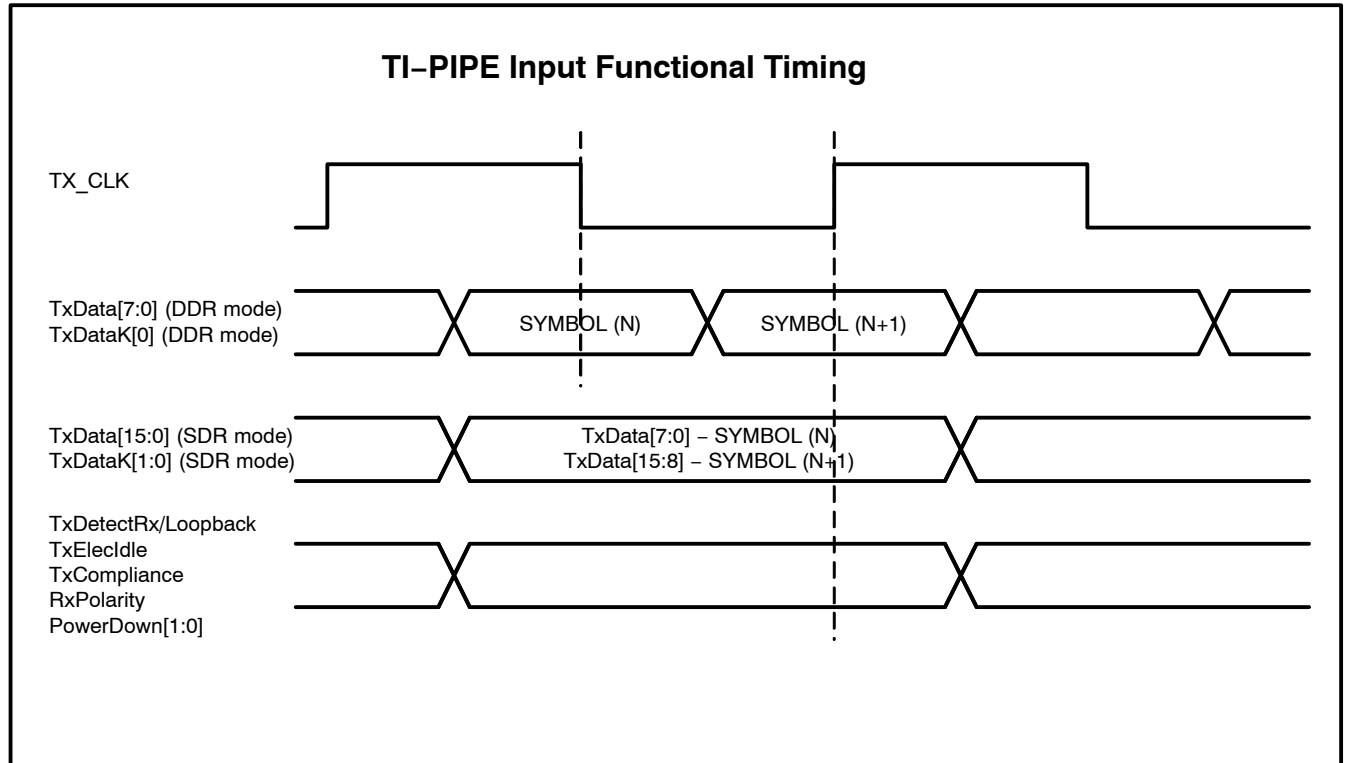

Figure 4-4. TI-PIPE Input Functional Timing

## 5 Application Information

### 5.1 Component Connection

Details regarding connection of components to the various terminals of the XIO1100 are discussed primarily in entries for each terminal in the terminal functions table.

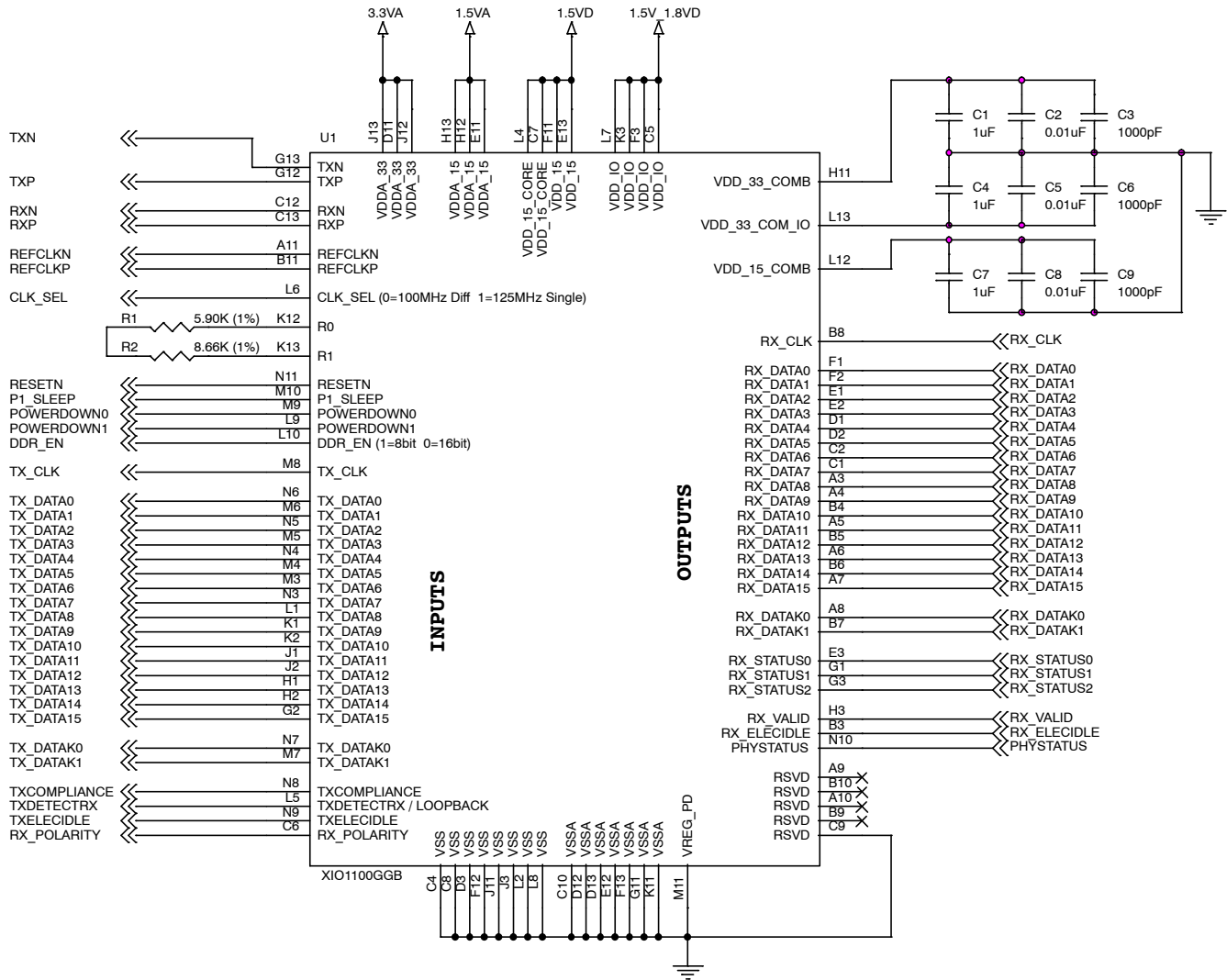

Figure 5-1. External Component Connections

Figure 5-1 does not show the decoupling capacitors for the power supplies. Texas Instruments recommends using at least one 0.1  $\mu\text{F}$  capacitor for each power supply pin. In addition to the 0.1  $\mu\text{F}$  capacitor, Texas Instruments recommends adding 0.01  $\mu\text{F}$  and 0.001  $\mu\text{F}$  capacitors for each analog power supply pin. Texas Instruments also recommends isolating the analog power from the digital power.

## 5.2 XIO1100 Component Placement

The filter network on VDD\_33\_COMB, VDD\_33\_COMB\_IO, and VDD\_15\_COMB needs to be placed as close as possible to each pin (specifically H11, L13, and L12). It is recommended that the trace width for these three pins be at least 10 mils.

The R0 and R1 terminals connect to an external resistor to set the drive current for the PCI Express TX driver. The recommended resistor value is 14,560- $\Omega$  with 1% tolerance. A 14,560- $\Omega$  resistor is a custom value. To eliminate the need for a custom resistor, two series resistors are recommended: a 5,900- $\Omega$  1% resistor and an 8,660- $\Omega$  1% resistor. Trace lengths must be kept short to minimize noise coupling into the reference resistor terminals.

## 5.3 Power Supply Filtering Recommendations

To meet the PCI Express jitter specifications, low-noise power supplies are required on several of the XIO1100 voltage terminals. The power terminals that require low-noise power include VDDA\_15 and VDDA\_33. This section provides guidelines for the filter design to create low-noise power sources.

The least expensive solution for low-noise power sources is to filter existing 3.3 V and 1.5 V power supplies. This solution requires analysis of the noise frequencies present on the power supplies. The XIO1100 has external interfaces operating at clock rates of 100 MHz, 125 MHz, 250 MHz, and 2.5 GHz. Other devices located near the XIO1100 may produce switching noise at different frequencies. Also, the power supplies that generate the 3.3 V and 1.5 V power rails may add low frequency ripple noise. Linear regulators have feedback loops that typically operate in the 100 kHz range. Switching power supplies typically have operating frequencies in the 500 kHz range. When analyzing power supply noise frequencies, the first, third, and fifth harmonic of every clock source should be considered.

Critical analog circuits within the XIO1100 must be shielded from this power-supply noise. The fundamental requirement for a filter design is to reduce power-supply noise to a peak-to-peak amplitude of less than 25 mV. This maximum noise amplitude should apply to all frequencies from 0 Hz to 12.5 GHz.

The following information should be considered when designing a power supply filter:

1. Ideally, the series resonance frequency for each filter component should be greater than the fifth harmonic of the maximum clock frequency. With a maximum clock frequency of 1.25 GHz, the third harmonic is 3.75 GHz and the fifth harmonic is 6.25 GHz. Finding inductors and capacitors with a series resonance frequency above 6.25 GHz is both difficult and expensive. Components with a series resonance frequency in the 4 to 6 GHz range are a good compromise.
2. The inductor(s) associated with the filter must have a dc resistance low enough to pass the required current for the connected power terminals. The voltage drop across the inductor must be low enough to meet the minus 10% voltage margin requirement associated with each XIO1100 power terminal. Power supply output voltage variation must be considered, as well as voltage drops associated with any connector pins and circuit board power distribution geometries.
3. The Q versus frequency curve associated with the inductor must be appropriate to reduce power terminal noise to less than the maximum peak-to-peak amplitude requirement for the XIO1100. Recommending a specific inductor is difficult, because every system design is different and therefore the noise frequencies and noise amplitudes are different. Many factors influence the inductor selection for the filter design. Power supplies must have adequate input and output filtering. A sufficient number of bulk and bypass capacitors is required to minimize switching noise. Assuming that board level power is properly filtered and minimal low frequency noise is present, frequencies less than 10 MHz, an inductor with a Q greater than 20 from approximately 10 MHz to 3 GHz should be adequate for most system applications.
4. The series component(s) in the filter may either be an inductor or a ferrite bead. Testing has been performed on both component types. When measuring PCI Express link jitter, the inductor or ferrite bead solutions produce equal results. When measuring circuit board EMI, the ferrite bead is a superior solution.

5. When designing filters associated with power distribution, the power supply is a low-impedance source, and the device power terminals are a low-impedance load. The best filter for this application is a T filter. See Figure 5–2 for a T filter circuit. Some systems may require this type of filter design if the power supplies or nearby components are exceptionally noisy. This type of filter design is recommended if a significant amount of low frequency noise (frequencies less than 10 MHz) is present in a system.
6. For most applications a Pi filter is adequate. See Figure 5–2 for a Pi filter circuit. When implementing a Pi filter, the two capacitors and the inductor must be located next to each other on the circuit board and must be connected together with wide, low impedance traces. Capacitor ground connections must be short and low-impedance.
7. If a significant amount of high frequency noise (frequencies greater than 300 MHz) is present in a system, creating an internal circuit board capacitor helps reduce this noise. This capacitor is accomplished by locating power and ground planes next to each other in the circuit board stack-up. A gap of 0.003 mils between the power and ground planes significantly reduces this high frequency noise.
8. Another option for filtering high-frequency logic noise is to create an internal board capacitor using signal layer copper plates. When a component requires a low-noise power supply, usually the Pi filter is located near the component. A plate capacitor may be created directly under the Pi filter. In the circuit board stack-up, select a signal layer that is physically located next to a ground plane. Then, generate an internal 0.25 inch by 0.25 inch plate on that signal layer. Assuming a 0.006 mil gap between the signal layer plate and the internal ground plane, this arrangement generates a 12 pF capacitor. By connecting this plate capacitor to the trace between the Pi filter and the component's power terminals, an internal circuit board high frequency bypass capacitor is created. This solution is extremely effective for switching frequencies above 300 MHz.

Figure 5–2 illustrates two different filter designs that may be used with the XIO1100 to provide low-noise power to critical power terminals.

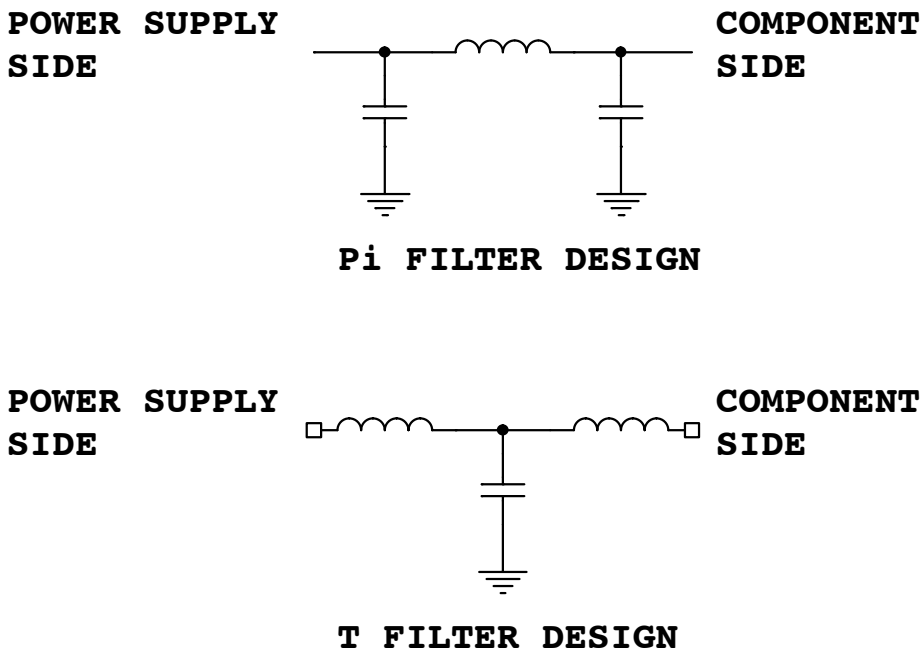

Figure 5–2. Filter Designs

## 5.4 PCIe Layout Guidelines

The XIO1100 TXP and TXN terminals comprise a low-voltage, 100- $\Omega$  differentially driven signal pair. The RXP and RXN terminals for the XIO1100 receive a low-voltage, 100- $\Omega$  differentially driven signal pair. The XIO1100 has integrated 50- $\Omega$  termination resistors to VSS on both the RXP and RXN terminals, eliminating the need for external components.

Each lane of the differential signal pair must be ac-coupled. The recommended value for the series capacitor is 0.1  $\mu$ F. To minimize stray capacitance associated with the series capacitor circuit board solder pads, 0402-sized capacitors are recommended.

When routing a 2.5-Gb/s low-voltage, 100- $\Omega$  differentially driven signal pair, the following circuit board design guidelines must be considered:

1. The PCI Express drivers and receivers are designed to operate with adequate bit error rate margins over a 20" maximum length signal pair routed through FR4 circuit board material.
2. Each differential signal pair must be 100- $\Omega$  differential impedance with each single-ended lane measuring in the range of 50- $\Omega$  to 55- $\Omega$  impedance to ground.
3. The differential signal trace lengths associated with a PCI Express high-speed link must be length matched to minimize signal jitter. This length-matching requirement applies only to the P and N signals within a differential pair. The transmitter differential pair does not need to be length matched to the receiver differential pair. The absolute maximum trace length difference between the TXP signal and TXN signal must be less than 5 mils. This value also applies to the RXP and RXN signal pair.
4. If a differential signal pair is broken into segments by vias, series capacitors, or connectors, the length of the positive signal trace must be length matched to the negative signal trace for each segment. Trace length differences over all segments are additive and must be less than 5 mils.
5. The location of the series capacitors is critical. For add-in cards, the series capacitors are located between the TXP/TXN terminals and the PCI Express connector. In addition, the capacitors are placed near the PCI Express connector. This translates to two capacitors on the motherboard for the downstream link, and two capacitors on the add-in card for the upstream link. If both the upstream device and the downstream device reside on the same circuit board, the capacitors are located near the TXP/TXN terminals for each link.
6. The number of vias must be minimized. Each signal trace via reduces the maximum trace length by approximately 2 inches. For example: if 6 vias are needed, the maximum trace length is 8 inches.
7. When routing a differential signal pair, 45-degree angles are preferred over 90-degree angles. Signal trace length matching is easier with 45-degree angles, and overall signal trace length is reduced.
8. The differential signal pairs must not be routed over gaps in the power planes or ground planes. This causes impedance mismatches.
9. If vias are used to change from one signal layer to another signal layer, it is important to maintain the same 50- $\Omega$  impedance reference to the ground plane. Changing reference planes causes signal trace impedance mismatches. If changing reference planes cannot be prevented, bypass capacitors connecting the two reference planes next to the signal trace vias help reduce the impedance mismatch.

If possible, the differential signal pairs must be routed on the top and bottom layers of a circuit board. Signal propagation speeds are faster on external signal layers.

The XIO1100 supports two options for the PCI Express reference clock: a 100-MHz common differential reference clock or a 125-MHz asynchronous single-ended reference clock. Both implementations are described.

The first option is a system-wide 100-MHz differential reference clock. A single clock source with multiple differential clock outputs is connected to all PCI Express devices in the system. The differential connection between the clock source and each PCI Express device is point-to-point. This system implementation is referred to as a common clock design.

The XIO1100 is optimized for this type of system clock design. The REFCLK+ and REFCLK- terminals provide differential reference clock inputs to the XIO1100. The circuit board routing rules associated with the 100-MHz differential reference clock are the same as the 2.5-Gb/s TX and RX link routing rules already described. The only difference is that the differential reference clock does not require series capacitors. The requirement is a dc connection from the clock driver output to the XIO1100 receiver input.

Terminating the differential clock signal is circuit-board-design specific. However, the XIO1100 design has no internal 50- $\Omega$ -to-ground termination resistors. Both REFCLK inputs, which are at approximately 20 k $\Omega$  to ground, are high-impedance inputs.

The second option is a 125-MHz asynchronous single-ended reference clock. For this case, the devices at each end of the PCI Express link have different clock sources. The XIO1100 has a 125-MHz single-ended reference clock option for asynchronous clocking designs. When the CLK\_SEL input terminal is tied to VSS, this clocking mode is enabled.

The single-ended reference clock is attached to the REFCLK+ terminal. The REFCLK+ input, which is at approximately 20 k $\Omega$ , is a high-impedance input. Any clock termination design must account for a high-impedance input. The REFCLK- terminal needs to be attached to VSS.

## 5.5 PIPE Interface Layout Guidelines

The XIO1100 PIPE interface can operate at either 125 MHz or 250 MHz, depending on the state of the DDR\_EN pin. Due to the high frequencies, high-speed design techniques should be employed. When routing the PIPE interface, the following circuit board design guidelines must be considered:

1. Due to the synchronous clock design of the XIO1100, the TX\_DATA path and the RX\_DATA path do not require a matched length with respect to each other.
2. The TX\_DATA path signals should be length matched to each other. The tolerance is dependent on the setup/hold times for both the FPGA or ASIC and the XIO1100.
3. The RX\_DATA path signals should be length matched to each other. The tolerance is dependent on the setup/hold times for both the FPGA or ASIC and the XIO1100.
4. Because of the edge rates of the PIPE interface (0.9 ns rise and fall time at a 10 pF load), it is important to keep the traces as short as possible. It is recommended to keep the trace length below 2.5 inches (assuming FR4 and a velocity of 172 ps per inch) to reduce the effect of crosstalk. Obviously, increasing the edge-to-edge spacing of the traces also reduces the effect of crosstalk.
5. In cases where the trace length is long and/or goes through a connector, it is recommended to use series termination resistors on each PIPE signal. These resistors need to be placed as close as possible to the source (resistors for the RX\_DATA path next to the XIO1100 and resistors for the TX\_DATA path next to the FPGA or ASIC). The value of the series termination resistor depends on the impedance ( $Z_0$ ) of the trace. Normally, the value of this resistor is  $Z_0$  minus the output impedance of the driver. For the XIO1100, the output impedance of the RX\_DATA path is 25- $\Omega$  (typ).

It is recommended to model your design before going to fabrication. An I/O Buffer Information Specification (IBIS) model of the XIO1100 is available upon request.

# 6 Mechanical Data

**PACKAGING INFORMATION**

Orderable Device	Status (1)	Package Type	Package Drawing	Pins	Package Qty	Eco Plan (2)	Lead finish/ Ball material (6)	MSL Peak Temp (3)	Op Temp (°C)	Device Marking (4/5)	Samples
XIO1100ZWS	ACTIVE	NFBGA	ZWS	100	160	RoHS & Green	SNAGCU	Level-3-260C-168 HR	0 to 70	XIO1100	<a href="#">Samples</a>
XIO1100ZWSR	ACTIVE	NFBGA	ZWS	100	1000	RoHS & Green	SNAGCU	Level-3-260C-168 HR	0 to 70	XIO1100	<a href="#">Samples</a>

(1) The marketing status values are defined as follows:

**ACTIVE:** Product device recommended for new designs.

**LIFEBUY:** TI has announced that the device will be discontinued, and a lifetime-buy period is in effect.

**NRND:** Not recommended for new designs. Device is in production to support existing customers, but TI does not recommend using this part in a new design.

**PREVIEW:** Device has been announced but is not in production. Samples may or may not be available.

**OBSELETE:** TI has discontinued the production of the device.

(2) **RoHS:** TI defines "RoHS" to mean semiconductor products that are compliant with the current EU RoHS requirements for all 10 RoHS substances, including the requirement that RoHS substance do not exceed 0.1% by weight in homogeneous materials. Where designed to be soldered at high temperatures, "RoHS" products are suitable for use in specified lead-free processes. TI may reference these types of products as "Pb-Free".

**RoHS Exempt:** TI defines "RoHS Exempt" to mean products that contain lead but are compliant with EU RoHS pursuant to a specific EU RoHS exemption.

**Green:** TI defines "Green" to mean the content of Chlorine (Cl) and Bromine (Br) based flame retardants meet JS709B low halogen requirements of <=1000ppm threshold. Antimony trioxide based flame retardants must also meet the <=1000ppm threshold requirement.

(3) MSL, Peak Temp. - The Moisture Sensitivity Level rating according to the JEDEC industry standard classifications, and peak solder temperature.

(4) There may be additional marking, which relates to the logo, the lot trace code information, or the environmental category on the device.

(5) Multiple Device Markings will be inside parentheses. Only one Device Marking contained in parentheses and separated by a "~" will appear on a device. If a line is indented then it is a continuation of the previous line and the two combined represent the entire Device Marking for that device.

(6) Lead finish/Ball material - Orderable Devices may have multiple material finish options. Finish options are separated by a vertical ruled line. Lead finish/Ball material values may wrap to two lines if the finish value exceeds the maximum column width.

**Important Information and Disclaimer:**The information provided on this page represents TI's knowledge and belief as of the date that it is provided. TI bases its knowledge and belief on information provided by third parties, and makes no representation or warranty as to the accuracy of such information. Efforts are underway to better integrate information from third parties. TI has taken and continues to take reasonable steps to provide representative and accurate information but may not have conducted destructive testing or chemical analysis on incoming materials and chemicals. TI and TI suppliers consider certain information to be proprietary, and thus CAS numbers and other limited information may not be available for release.

In no event shall TI's liability arising out of such information exceed the total purchase price of the TI part(s) at issue in this document sold by TI to Customer on an annual basis.



**TAPE AND REEL INFORMATION**

**QUADRANT ASSIGNMENTS FOR PIN 1 ORIENTATION IN TAPE**



\*All dimensions are nominal

Device	Package Type	Package Drawing	Pins	SPQ	Reel Diameter (mm)	Reel Width W1 (mm)	A0 (mm)	B0 (mm)	K0 (mm)	P1 (mm)	W (mm)	Pin1 Quadrant
XIO1100ZWSR	NFBGA	ZWS	100	1000	330.0	24.4	12.35	12.35	2.3	16.0	24.0	Q1

**TAPE AND REEL BOX DIMENSIONS**

\*All dimensions are nominal

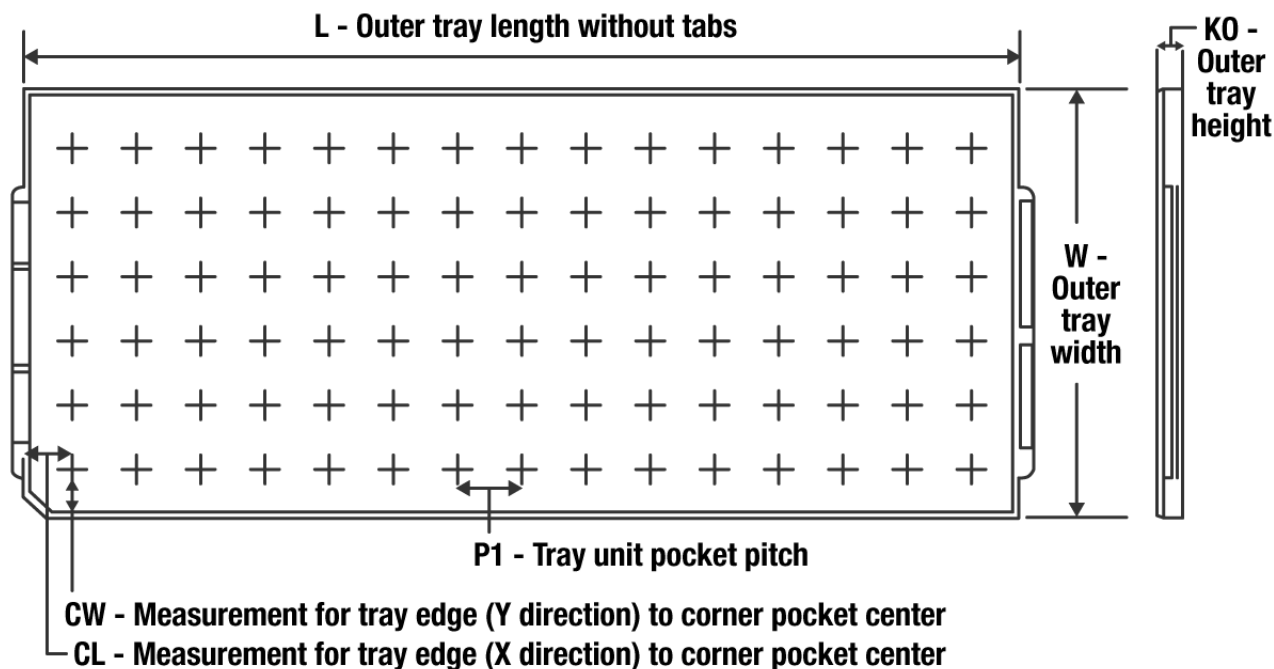
Device	Package Type	Package Drawing	Pins	SPQ	Length (mm)	Width (mm)	Height (mm)
XIO1100ZWSR	NFBGA	ZWS	100	1000	336.6	336.6	41.3

**TRAY**

Chamfer on Tray corner indicates Pin 1 orientation of packed units.

\*All dimensions are nominal

Device	Package Name	Package Type	Pins	SPQ	Unit array matrix	Max temperature (°C)	L (mm)	W (mm)	K0 (µm)	P1 (mm)	CL (mm)	CW (mm)
XIO1100ZWS	ZWS	NFBGA	100	160	8 x 20	150	315	135.9	7620	15.4	11.2	19.65

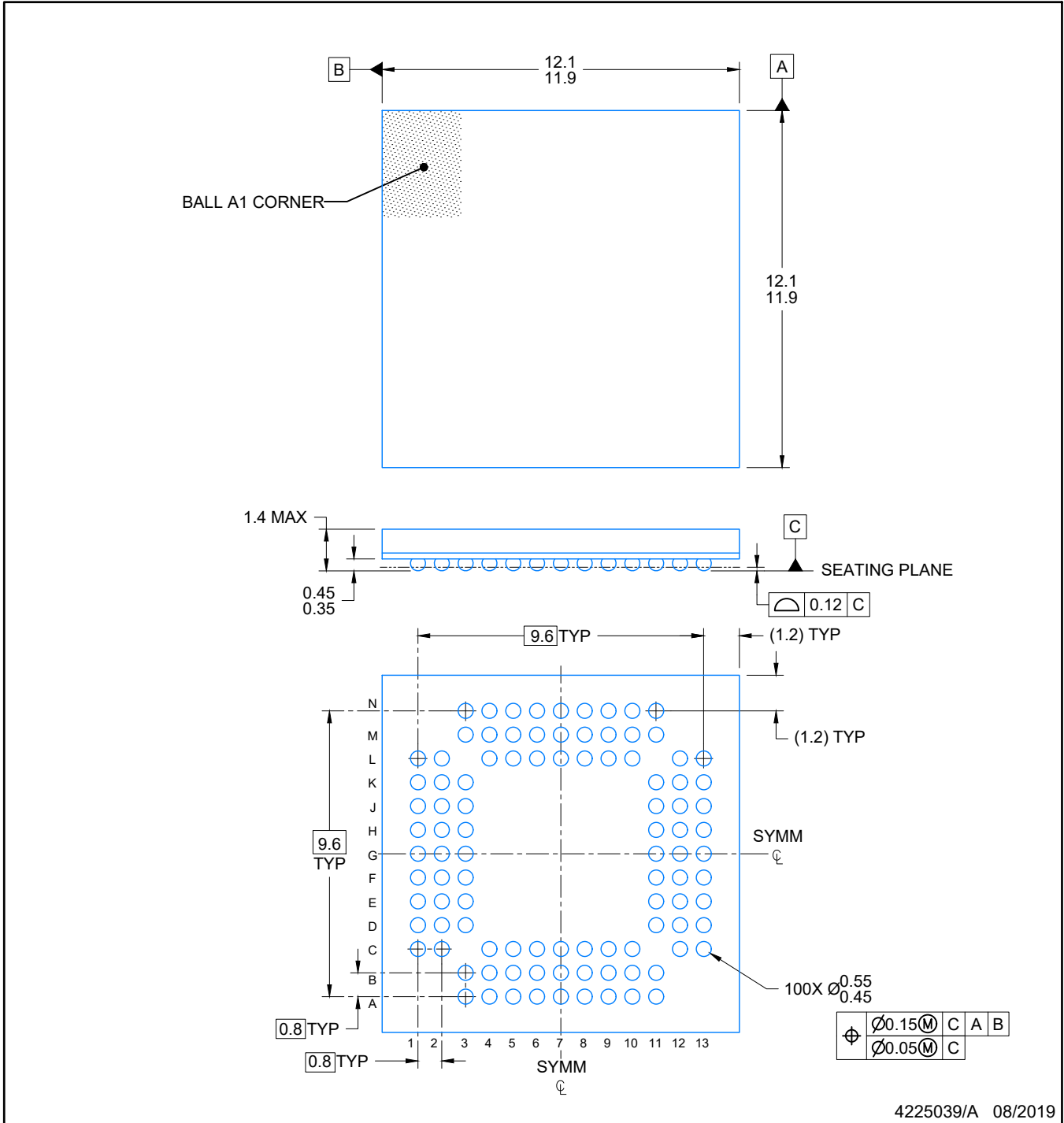

4225039/A 08/2019

NOTES:

NanoFree is a trademark of Texas Instruments.

1. All linear dimensions are in millimeters. Any dimensions in parenthesis are for reference only. Dimensioning and tolerancing per ASME Y14.5M.
2. This drawing is subject to change without notice.

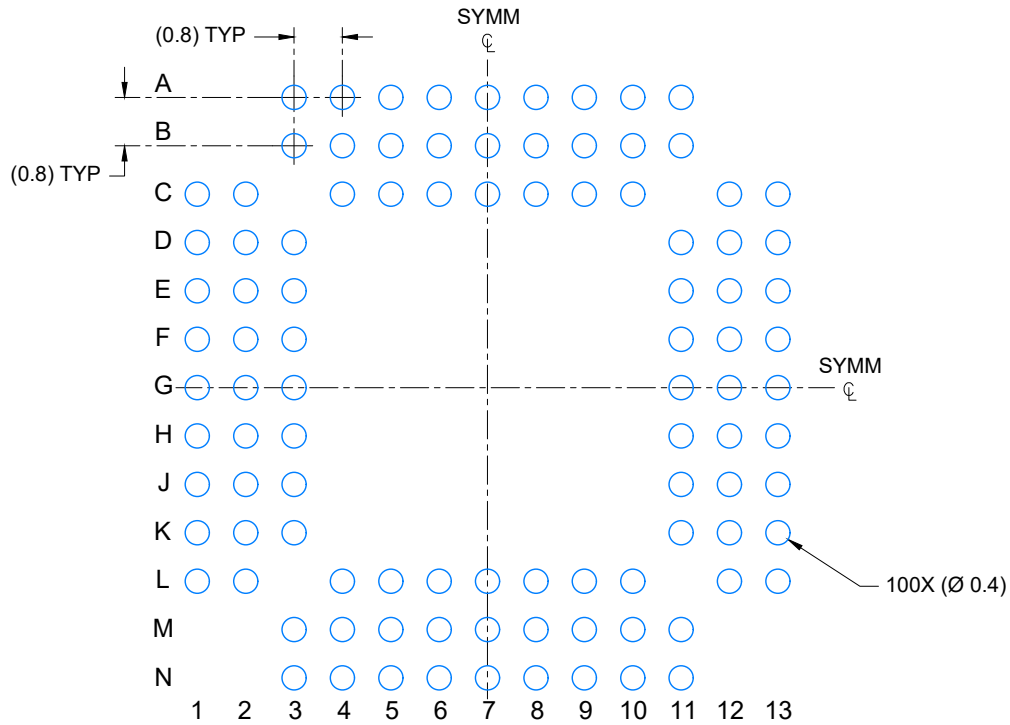

LAND PATTERN EXAMPLE  
SCALE: 8X

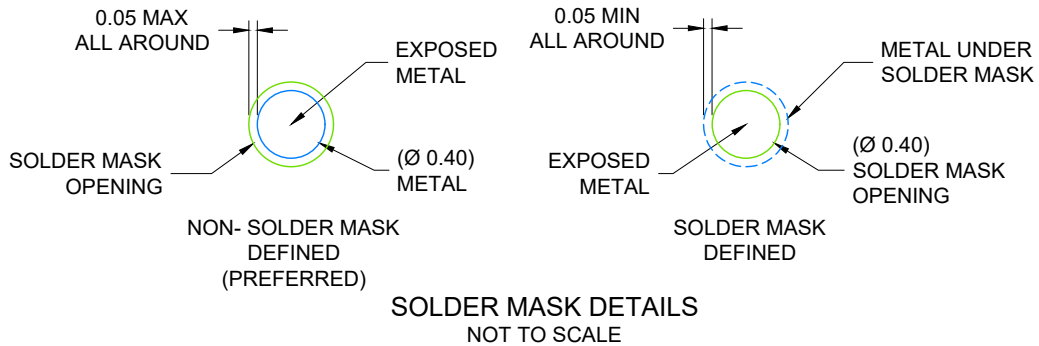

4225039/A 08/2019

NOTES: (continued)

- Final dimensions may vary due to manufacturing tolerance considerations and also routing constraints. Refer to Texas Instruments Literature number SNVA009 ([www.ti.com/lit/snva009](http://www.ti.com/lit/snva009)).

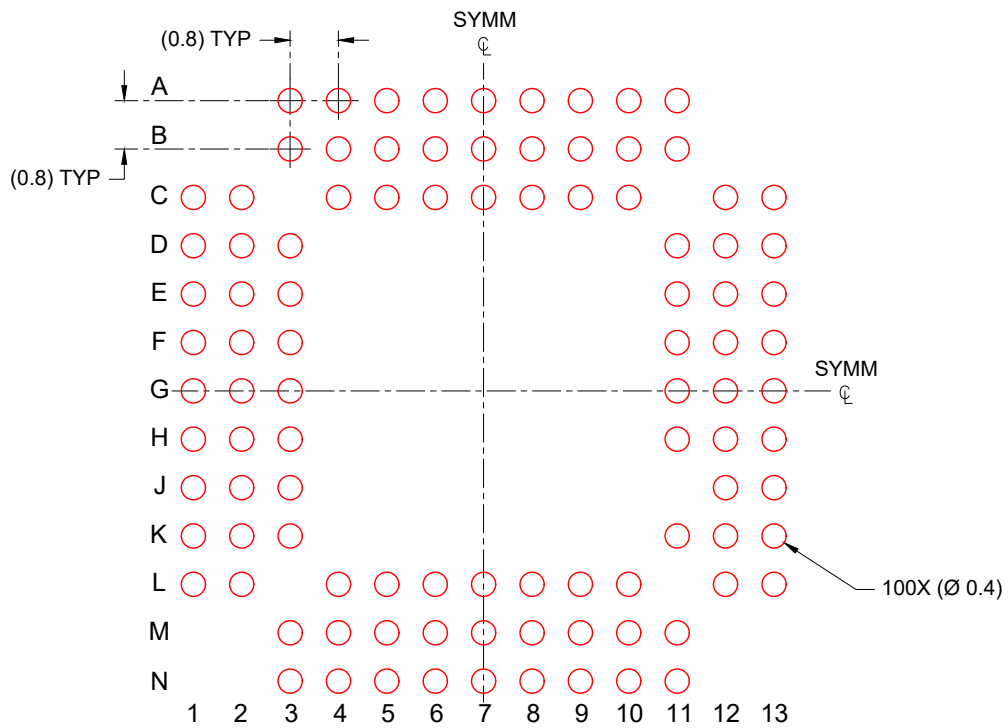

SOLDER PASTE EXAMPLE  
BASED ON 0.150 mm THICK STENCIL  
SCALE: 8X

4225039/A 08/2019

NOTES: (continued)

- 4. Laser cutting apertures with trapezoidal walls and rounded corners may offer better paste release.

## IMPORTANT NOTICE AND DISCLAIMER

TI PROVIDES TECHNICAL AND RELIABILITY DATA (INCLUDING DATA SHEETS), DESIGN RESOURCES (INCLUDING REFERENCE DESIGNS), APPLICATION OR OTHER DESIGN ADVICE, WEB TOOLS, SAFETY INFORMATION, AND OTHER RESOURCES "AS IS" AND WITH ALL FAULTS, AND DISCLAIMS ALL WARRANTIES, EXPRESS AND IMPLIED, INCLUDING WITHOUT LIMITATION ANY IMPLIED WARRANTIES OF MERCHANTABILITY, FITNESS FOR A PARTICULAR PURPOSE OR NON-INFRINGEMENT OF THIRD PARTY INTELLECTUAL PROPERTY RIGHTS.

These resources are intended for skilled developers designing with TI products. You are solely responsible for (1) selecting the appropriate TI products for your application, (2) designing, validating and testing your application, and (3) ensuring your application meets applicable standards, and any other safety, security, regulatory or other requirements.

These resources are subject to change without notice. TI grants you permission to use these resources only for development of an application that uses the TI products described in the resource. Other reproduction and display of these resources is prohibited. No license is granted to any other TI intellectual property right or to any third party intellectual property right. TI disclaims responsibility for, and you will fully indemnify TI and its representatives against, any claims, damages, costs, losses, and liabilities arising out of your use of these resources.

TI's products are provided subject to [TI's Terms of Sale](#) or other applicable terms available either on [ti.com](http://ti.com) or provided in conjunction with such TI products. TI's provision of these resources does not expand or otherwise alter TI's applicable warranties or warranty disclaimers for TI products.

TI objects to and rejects any additional or different terms you may have proposed.

Mailing Address: Texas Instruments, Post Office Box 655303, Dallas, Texas 75265  
Copyright © 2022, Texas Instruments Incorporated