

## ULQ200xA-Q1 High-Voltage High-Current Darlington Transistor Arrays

### 1 Features

- Qualified for Automotive Applications
- ESD Protection Exceeds 200 V Using Machine Model (C = 200 pF, R = 0)
- 500-mA-Rated Collector Current (Single Output)
- High-Voltage Outputs: 50 V
- Output Clamp Diodes
- Inputs Compatible With Various Types of Logic
- Relay-Driver Applications

### 2 Applications

- Relay Drivers
- Stepper and DC Brushed Motor Drivers
- Lamp Drivers
- Display Drivers (LED and Gas Discharge)
- Line Drivers
- Logic Buffers

### 3 Description

The ULQ200xA-Q1 devices are high-voltage high-current Darlington transistor arrays. Each consists of seven npn Darlington pairs that feature high-voltage outputs with common-cathode clamp diodes for switching inductive loads. The collector-current rating of a single Darlington pair is 500 mA. The Darlington pairs can be paralleled for higher current capability.

The ULQ2003A-Q1 has a 2.7-k $\Omega$  series base resistor for each Darlington pair, for operation directly with TTL or 5-V CMOS devices. The ULQ2004A-Q1 has a 10.5-k $\Omega$  series base resistor to allow operation directly from CMOS devices that use supply voltages of 6 V to 15 V. The required input current of the ULQ2004A-Q1 is below that of the ULQ2003A-Q1.

#### Device Information<sup>(1)</sup>

PART NUMBER	PACKAGE	BODY SIZE (NOM)
ULQ2003A-Q1	SOIC (16)	9.90 mm x 3.90 mm
	TSSOP (16)	5.00 mm x 4.40 mm
ULQ2004A-Q1	SOIC (16)	9.90 mm x 3.90 mm

(1) For all available packages, see the orderable addendum at the end of the data sheet.

#### Simplified Block Diagram

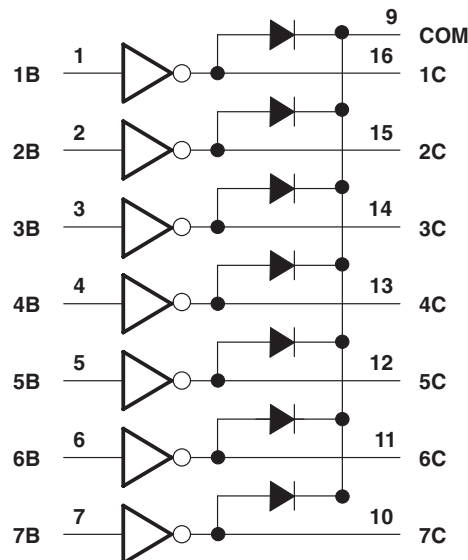

## Table of Contents

<p><b>1 Features</b> ..... 1</p> <p><b>2 Applications</b> ..... 1</p> <p><b>3 Description</b> ..... 1</p> <p><b>4 Revision History</b>..... 2</p> <p><b>5 Pin Configuration and Functions</b> ..... 3</p> <p><b>6 Specifications</b>..... 4</p> <p>    6.1 Absolute Maximum Ratings ..... 4</p> <p>    6.2 ESD Ratings..... 4</p> <p>    6.3 Recommended Operating Conditions..... 4</p> <p>    6.4 Thermal Information ..... 4</p> <p>    6.5 Electrical Characteristics, ULQ2003AT and ULQ2003AQ..... 5</p> <p>    6.6 Electrical Characteristics, ULQ2004AT..... 5</p> <p>    6.7 Switching Characteristics, ULQ2003A and ULQ2004A ..... 6</p> <p>    6.8 Dissipation Ratings ..... 6</p> <p>    6.9 Typical Characteristics ..... 6</p> <p><b>7 Parameter Measurement Information</b> ..... 7</p> <p><b>8 Detailed Description</b> ..... 9</p> <p>    8.1 Overview ..... 9</p>	<p>    8.2 Functional Block Diagram ..... 9</p> <p>    8.3 Feature Description..... 10</p> <p>    8.4 Device Functional Modes..... 10</p> <p><b>9 Application and Implementation</b> ..... 11</p> <p>    9.1 Application Information..... 11</p> <p>    9.2 Typical Application ..... 11</p> <p>    9.3 System Examples ..... 14</p> <p><b>10 Power Supply Recommendations</b> ..... 15</p> <p><b>11 Layout</b>..... 15</p> <p>    11.1 Layout Guidelines ..... 15</p> <p>    11.2 Layout Example ..... 15</p> <p><b>12 Device and Documentation Support</b> ..... 16</p> <p>    12.1 Related Links ..... 16</p> <p>    12.2 Community Resources..... 16</p> <p>    12.3 Trademarks ..... 16</p> <p>    12.4 Electrostatic Discharge Caution..... 16</p> <p>    12.5 Glossary ..... 16</p> <p><b>13 Mechanical, Packaging, and Orderable Information</b> ..... 16</p>
--	---

## 4 Revision History

NOTE: Page numbers for previous revisions may differ from page numbers in the current version.

Changes from Revision D (April 2010) to Revision E	Page
<ul style="list-style-type: none"> <li>• Added <i>Pin Configuration and Functions</i> section, <i>ESD Ratings</i> table, <i>Feature Description</i> section, <i>Device Functional Modes</i>, <i>Application and Implementation</i> section, <i>Power Supply Recommendations</i> section, <i>Layout</i> section, <i>Device and Documentation Support</i> section, and <i>Mechanical, Packaging, and Orderable Information</i> section ..... 1</li> </ul>	1

## 5 Pin Configuration and Functions

**D or PW Package  
16-Pin SOIC or TSSOP  
Top View**

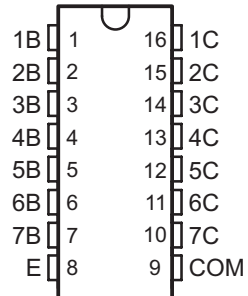

**Pin Functions**

PIN		I/O	DESCRIPTION
NO.	NAME		
1	1B	I	Channel 1 through 7 Darlington base input
2	2B		
3	3B		
4	4B		
5	5B		
6	6B		
7	7B		
8	E	—	Common emitter shared by all channels (typically tied to ground)
9	COM	—	Common cathode node for flyback diodes (required for inductive loads)
10	7C	O	Channel 1 through 7 Darlington collector output
11	6C		
12	5C		
13	4C		
14	3C		
15	2C		
16	1C		

## 6 Specifications

### 6.1 Absolute Maximum Ratings

 at 25°C free-air temperature (unless otherwise noted)<sup>(1)</sup>

		MIN	MAX	UNIT	
V <sub>CE</sub>	Collector-emitter voltage		50	V	
	Clamp diode reverse voltage <sup>(2)</sup>		50	V	
V <sub>I</sub>	Input voltage <sup>(2)</sup>		30	V	
	Peak collector current	See <a href="#">Figure 16</a>	500	mA	
I <sub>OK</sub>	Output clamp current		500	mA	
	Total emitter-terminal current		–2.5	A	
P <sub>D</sub>	Continuous total power dissipation	See <a href="#">Dissipation Ratings</a>			
T <sub>A</sub>	Operating free-air temperature	ULQ200xAT	–40	105	°C
		ULQ200xAQ	–40	125	
T <sub>J</sub>	Junction temperature		150	°C	
T <sub>stg</sub>	Storage temperature	–65	150	°C	

- (1) Stresses beyond those listed under Absolute Maximum Ratings may cause permanent damage to the device. These are stress ratings only, and functional operation of the device at these or any other conditions beyond those indicated under [Recommended Operating Conditions](#) is not implied. Exposure to absolute-maximum-rated conditions for extended periods may affect device reliability.
- (2) All voltage values are with respect to the emitter/substrate terminal E, unless otherwise noted.

### 6.2 ESD Ratings

		VALUE	UNIT	
V <sub>(ESD)</sub>	Electrostatic discharge	Human-body model (HBM), per AEC Q100-002 <sup>(1)</sup>	±2000	V
		Charged-device model (CDM), per AEC Q100-011	±500	

- (1) AEC Q100-002 indicates HBM stressing is done in accordance with the ANSI/ESDA/JEDEC JS-001 specification.

### 6.3 Recommended Operating Conditions

over operating free-air temperature range (unless otherwise noted)

		MIN	MAX	UNIT
V <sub>CE</sub>	Collector-emitter voltage	0	50	V
T <sub>J</sub>	Junction temperature	–40	125	°C

### 6.4 Thermal Information

THERMAL METRIC <sup>(1)</sup>		ULQ2003A-Q1, ULQ2004A-Q1	ULQ2003A-Q1	UNIT
		D (SOIC)	PW (TSSOP)	
		16 PINS	16 PINS	
R <sub>θJA</sub>	Junction-to-ambient thermal resistance	73	108	°C/W

- (1) For more information about traditional and new thermal metrics, see the *Semiconductor and IC Package Thermal Metrics* application report, [SPRA953](#).

## 6.5 Electrical Characteristics, ULQ2003AT and ULQ2003AQ

over recommended operating conditions (unless otherwise noted)

PARAMETER		TEST CONDITIONS		MIN	TYP	MAX	UNIT
$V_{I(on)}$	On-state input voltage	$V_{CE} = 2\text{ V}$ , see <a href="#">Figure 10</a>	$I_C = 200\text{ mA}$			2.7	V
			$I_C = 250\text{ mA}$			2.9	
			$I_C = 300\text{ mA}$			3	
$V_{CE(sat)}$	Collector-emitter saturation voltage	$I_I = 250\text{ }\mu\text{A}, I_C = 100\text{ mA}$ , see <a href="#">Figure 9</a>	ULQ2003AT		0.9	1.2	V
			ULQ2003AQ		1	1.3	
		$I_I = 350\text{ }\mu\text{A}, I_C = 200\text{ mA}$ , see <a href="#">Figure 9</a>	ULQ2003AT		1	1.4	
			ULQ2003AQ		1	1.5	
		$I_I = 500\text{ }\mu\text{A}, I_C = 350\text{ mA}$ , see <a href="#">Figure 9</a>	ULQ2003AT		1.2	1.7	
			ULQ2003AQ		1.2	1.8	
$I_{CEX}$	Collector cutoff current	$V_{CE} = 50\text{ V}$ , $I_I = 0$ , see <a href="#">Figure 3</a>	$T_A = 25^\circ\text{C}$			100	$\mu\text{A}$
			$T_A = 105^\circ\text{C}$ , ULQ2003AT			165	
$V_F$	Clamp forward voltage	$I_F = 350\text{ mA}$ , see <a href="#">Figure 8</a>			1.7	2.2	V
$I_{I(off)}$	Off-state input current	$V_{CE} = 50\text{ V}$ , $I_C = 500\text{ }\mu\text{A}$ , see <a href="#">Figure 5</a>		30	65		$\mu\text{A}$
$I_I$	Input current	$V_I = 3.85\text{ V}$ , see <a href="#">Figure 6</a>			0.93	1.35	mA
$I_R$	Clamp reverse current	$V_R = 50\text{ V}$ , $T_A = 25^\circ\text{C}$ , see <a href="#">Figure 7</a>				100	$\mu\text{A}$
$C_i$	Input capacitance	$V_I = 0$ , $f = 1\text{ MHz}$			15	25	pF

## 6.6 Electrical Characteristics, ULQ2004AT

over recommended operating conditions (unless otherwise noted)

PARAMETER		TEST CONDITIONS		MIN	TYP	MAX	UNIT	
$V_{I(on)}$	On-state input voltage	$V_{CE} = 2\text{ V}$ , see <a href="#">Figure 10</a>	$I_C = 125\text{ mA}$			5	V	
			$I_C = 200\text{ mA}$			6		
			$I_C = 275\text{ mA}$			7		
			$I_C = 350\text{ mA}$			8		
$V_{CE(sat)}$	Collector-emitter saturation voltage	$I_I = 250\text{ }\mu\text{A}, I_C = 100\text{ mA}$ , see <a href="#">Figure 9</a>			0.9	1.1	V	
			$I_I = 350\text{ }\mu\text{A}, I_C = 200\text{ mA}$ , see <a href="#">Figure 9</a>			1		1.3
			$I_I = 500\text{ }\mu\text{A}, I_C = 350\text{ mA}$ , see <a href="#">Figure 9</a>			1.2		1.6
$I_{CEX}$	Collector cutoff current	$V_{CE} = 50\text{ V}$ , $I_I = 0$ , See <a href="#">Figure 3</a>	$T_A = 25^\circ\text{C}$			50	$\mu\text{A}$	
			$T_A = 105^\circ\text{C}$					
		$V_{CE} = 50\text{ V}$ , see <a href="#">Figure 4</a>	$I_I = 0$			100		
			$V_I = 1\text{ V}$			500		
$V_F$	Clamp forward voltage	$I_F = 350\text{ mA}$ , see <a href="#">Figure 8</a>			1.7	2.1	V	
$I_{I(off)}$	Off-state input current	$V_{CE} = 50\text{ V}$ , $I_C = 500\text{ }\mu\text{A}$ , see <a href="#">Figure 5</a>		50	65		$\mu\text{A}$	
$I_I$	Input current	$V_I = 5\text{ V}$ , see <a href="#">Figure 6</a>			0.35	0.5	mA	
		$V_I = 12\text{ V}$ , , see <a href="#">Figure 6</a>			1	1.45		
$I_R$	Clamp reverse current	$V_R = 50\text{ V}$ , see <a href="#">Figure 7</a>	$T_A = 25^\circ\text{C}$			50	$\mu\text{A}$	
			$T_A = 105^\circ\text{C}$			100		
$C_i$	Input capacitance	$V_I = 0$ , $f = 1\text{ MHz}$			15	25	pF	

### 6.7 Switching Characteristics, ULQ2003A and ULQ2004A

over recommended operating conditions (unless otherwise noted)

PARAMETER		TEST CONDITIONS	MIN	TYP	MAX	UNIT
$t_{PLH}$	Propagation delay time, low- to high-level output	See Figure 11		1	10	$\mu s$
$t_{PHL}$	Propagation delay time, high- to low-level output	See Figure 11		1	10	$\mu s$
$V_{OH}$	High-level output voltage after switching	$V_S = 50 V, I_O = 300 mA$ , See Figure 12	$V_S - 500$			mV

### 6.8 Dissipation Ratings

PACKAGE	$T_A = 25^\circ C$ POWER RATING	DERATING FACTOR ABOVE $T_A = 25^\circ C$	$T_A = 85^\circ C$ POWER RATING	$T_A = 105^\circ C$ POWER RATING	$T_A = 125^\circ C$ POWER RATING
D	950 mW	7.6 mW/ $^\circ C$	494 mW	342 mW	190 mW

### 6.9 Typical Characteristics

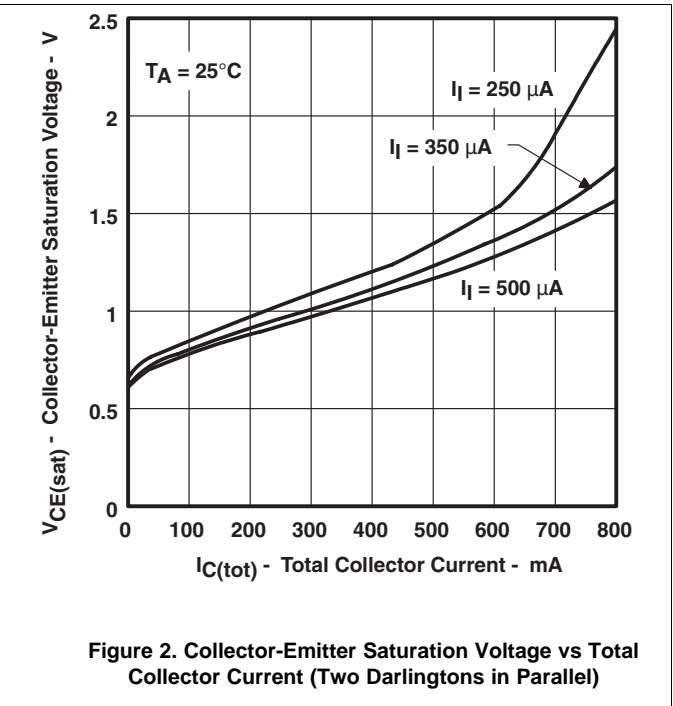
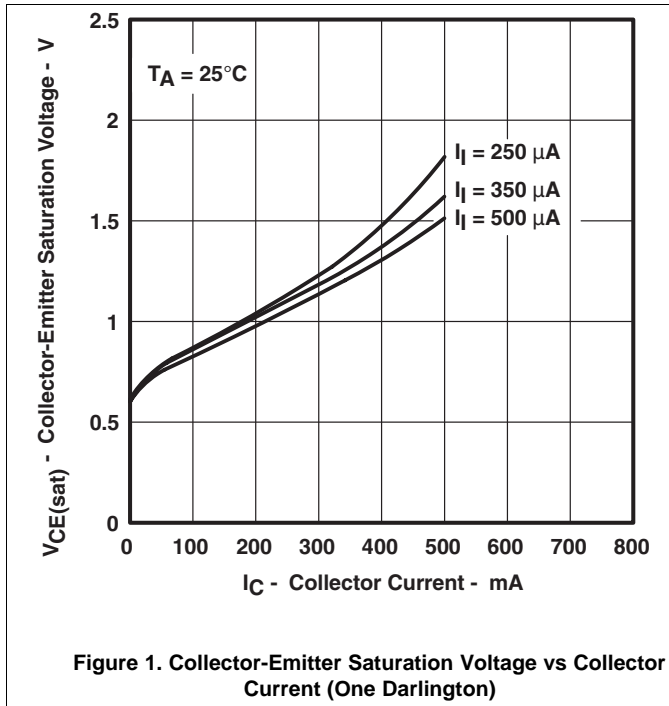

## 7 Parameter Measurement Information

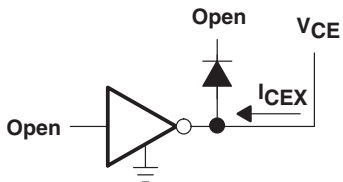

Figure 3.  $I_{CEX}$  Test Circuit

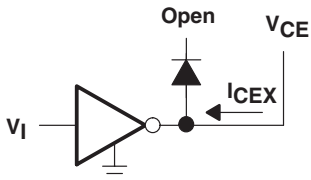

Figure 4.  $I_{CEX}$  Test Circuit

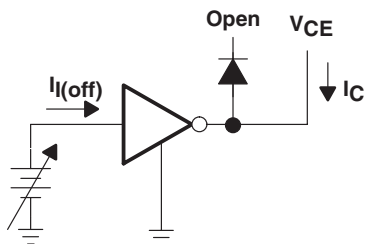
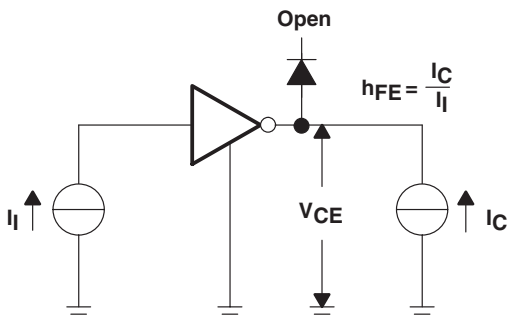

Figure 5.  $I_{I(off)}$  Test Circuit



- A.  $I_I$  is fixed for measuring  $V_{CE(sat)}$ , variable for measuring  $h_{FE}$ .

Figure 9.  $h_{FE}$ ,  $V_{CE(sat)}$  Test Circuit

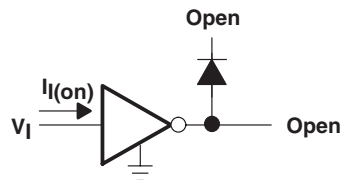

Figure 6.  $I_I$  Test Circuit

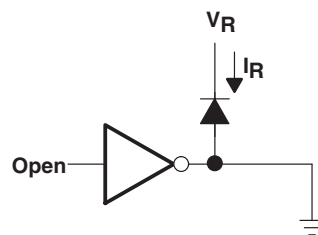

Figure 7.  $I_R$  Test Circuit

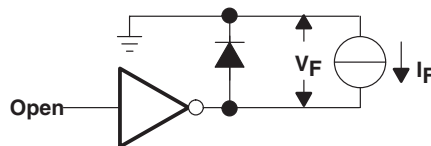

Figure 8.  $V_F$  Test Circuit

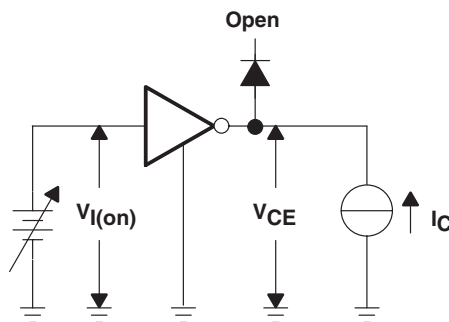
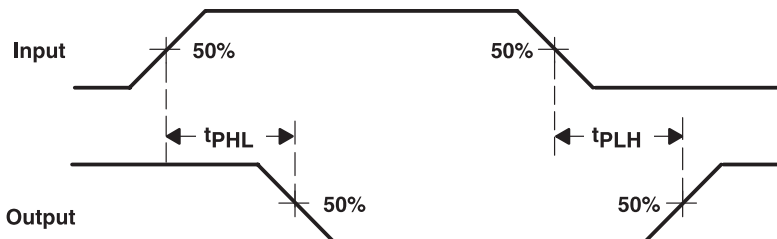
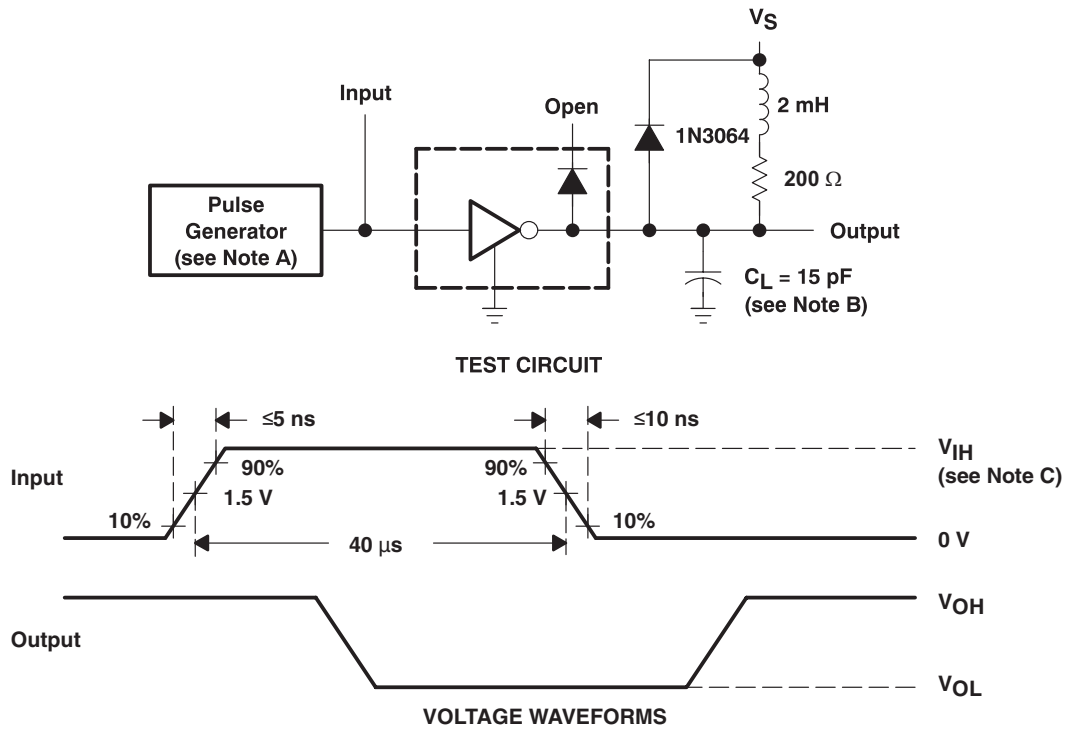

Figure 10.  $V_{I(on)}$  Test Circuit



VOLTAGE WAVEFORMS

Figure 11. Propagation Delay-Time Waveforms



- A. The pulse generator has the following characteristics: PRR = 12.5 kHz,  $Z_O = 50 \Omega$ .
- B.  $C_L$  includes probe and jig capacitance.
- C. For testing the ULQ2003A,  $V_{IH} = 3 \text{ V}$ ; for the ULQ2004A,  $V_{IH} = 8 \text{ V}$ .

**Figure 12. Latch-Up Test Circuit and Voltage Waveforms**

## 8 Detailed Description

### 8.1 Overview

This standard device has proven ubiquity and versatility across a wide range of applications. This is due to integration of 7 Darlington transistors of the device that are capable of sinking up to 500 mA and wide GPIO range capability.

The ULQ200xA-Q1 devices comprise seven high-voltage, high-current NPN Darlington transistor pairs. All units feature a common emitter and open collector outputs. To maximize their effectiveness, these units contain suppression diodes for inductive loads. The ULN200xA-Q1 devices have a series base resistor to each Darlington pair, thus allowing operation directly with TTL or CMOS operating at supply voltages of 5 V or 3.3 V. The ULQ2003xA-Q1 device offers solutions to a great many interface needs, including solenoids, relays, lamps, small motors, and LEDs. Applications requiring sink currents beyond the capability of a single output may be accommodated by paralleling the outputs.

This device can operate over a wide temperature range (–40°C to 105°C for ULQ200xAT or –40°C to 125°C for ULQ2003AQ).

### 8.2 Functional Block Diagram

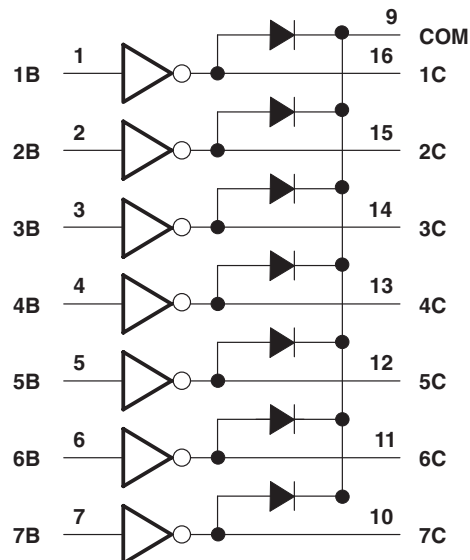

**Figure 13. Logic Diagram**

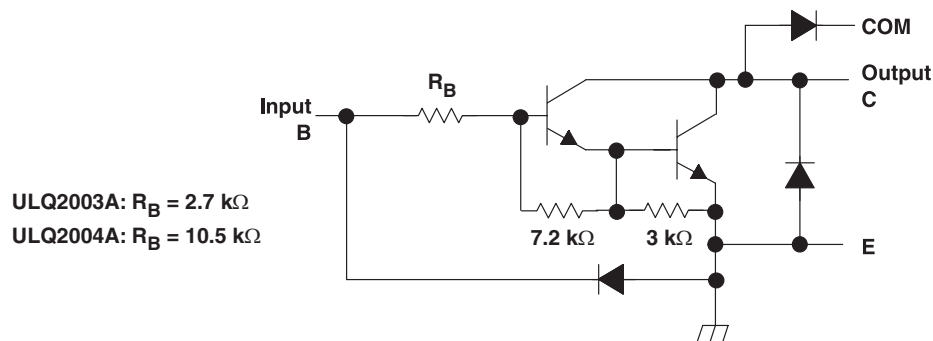
**Functional Block Diagram (continued)**

- A. All resistor values shown are nominal.
- B. The collector-emitter diode is a parasitic structure and should not be used to conduct current. If the collector(s) go below ground an external Schottky diode should be added to clamp negative undershoots.

**Figure 14. Schematics (Each Darlington Pair)**
**8.3 Feature Description**

Each channel of the ULQ200xA-Q1 devices consist of Darlington connected NPN transistors. This connection creates the effect of a single transistor with a very high-current gain ( $\beta^2$ ). This can be as high as 10,000 A/A at certain currents. The very high  $\beta$  allows for high-output current drive with a very low input current, essentially equating to operation with low GPIO voltages.

The GPIO voltage is converted to base current through the 2.7-k $\Omega$  or 10.5-k $\Omega$  resistor connected between the input and base of the predriver Darlington NPN. The 7.2-k $\Omega$  and 3-k $\Omega$  resistors connected between the base and emitter of each respective NPN act as pulldowns and suppress the amount of leakage that may occur from the input.

The diodes connected between the output and COM pin is used to suppress the kick-back voltage from an inductive load that is excited when the NPN drivers are turned off (stop sinking) and the stored energy in the coils causes a reverse current to flow into the coil supply through the kick-back diode.

In normal operation the diodes on base and collector pins to emitter will be reversed biased. If these diodes are forward biased, internal parasitic NPN transistors will draw (a nearly equal) current from other (nearby) device pins.

**8.4 Device Functional Modes**
**8.4.1 Inductive Load Drive**

When the COM pin is tied to the coil supply voltage, ULQ200xA-Q1 devices are able to drive inductive loads and suppress the kick-back voltage through the internal free-wheeling diodes.

**8.4.2 Resistive Load Drive**

When driving a resistive load, a pullup resistor is needed in order for the ULQ200xA-Q1 devices to sink current and for there to be a logic high level. The COM pin can be left floating for these applications.

## 9 Application and Implementation

### NOTE

Information in the following applications sections is not part of the TI component specification, and TI does not warrant its accuracy or completeness. TI's customers are responsible for determining suitability of components for their purposes. Customers should validate and test their design implementation to confirm system functionality.

### 9.1 Application Information

Typically, the ULQ200xA-Q1 device drives a high-voltage or high-current (or both) peripheral from an MCU or logic device that cannot tolerate these conditions. This design is a common application of ULQ200xA-Q1 device, driving inductive loads. This includes motors, solenoids and relays. Figure 15 shows an example of driving multiple inductive loads.

### 9.2 Typical Application

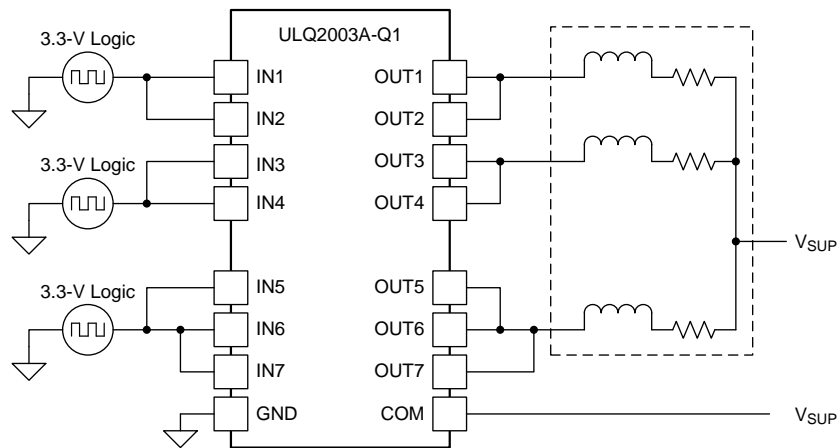

Figure 15. ULQ2003A-Q1 Device as Inductive Load Driver

#### 9.2.1 Design Requirements

For this design example, use the parameters listed in Table 1 as the input parameters.

Table 1. Design Parameters

DESIGN PARAMETER	EXAMPLE VALUE
GPIO voltage	3.3 V or 5 V
Coil supply voltage	12 V to 48 V
Number of channels	7
Output current ( $R_{COIL}$ )	20 mA to 300 mA per channel
Duty cycle	100%

## 9.2.2 Detailed Design Procedure

When using ULQ2003A-Q1 device in a coil driving application, determine the following:

- Input voltage range
- Temperature range
- Output and drive current
- Power dissipation

### 9.2.2.1 Drive Current

The coil voltage ( $V_{SUP}$ ), coil resistance ( $R_{COIL}$ ), and low-level output voltage ( $V_{CE(SAT)}$  or  $V_{OL}$ ) determine the coil current.

$$I_{COIL} = (V_{SUP} - V_{CE(SAT)}) / R_{COIL} \quad (1)$$

### 9.2.2.2 Low-Level Output Voltage

The low-level output voltage ( $V_{OL}$ ) is the same as  $V_{CE(SAT)}$  and can be determined by [Figure 1](#) or [Figure 2](#).

### 9.2.2.3 Power Dissipation and Temperature

The number of coils driven is dependent on the coil current and on-chip power dissipation. The number of coils driven can be determined by [Figure 16](#).

For a more accurate determination of number of coils possible, use [Equation 2](#) to calculate ULQ200xA-Q1 device on-chip power dissipation  $P_D$ :

$$P_D = \sum_{i=1}^N V_{OLi} \times I_{Li}$$

where

- $N$  is the number of channels active together
- $V_{OLi}$  is the  $OUT_i$  pin voltage for the load current  $I_{Li}$ . This is the same as  $V_{CE(SAT)}$  (2)

To ensure reliability of ULQ200xA-Q1 device and the system, the on-chip power dissipation must be lower than or equal to the maximum allowable power dissipation ( $PD_{(MAX)}$ ) dictated by [Equation 3](#).

$$PD_{(MAX)} = \frac{(T_{J(MAX)} - T_A)}{\theta_{JA}}$$

where

- $T_{J(max)}$  is the target maximum junction temperature
- $T_A$  is the operating ambient temperature
- $R_{\theta JA}$  is the package junction to ambient thermal resistance (3)

Limit the die junction temperature of the ULQ200xA-Q1 device to less than 125°C. The IC junction temperature is directly proportional to the on-chip power dissipation.

9.2.3 Application Curve

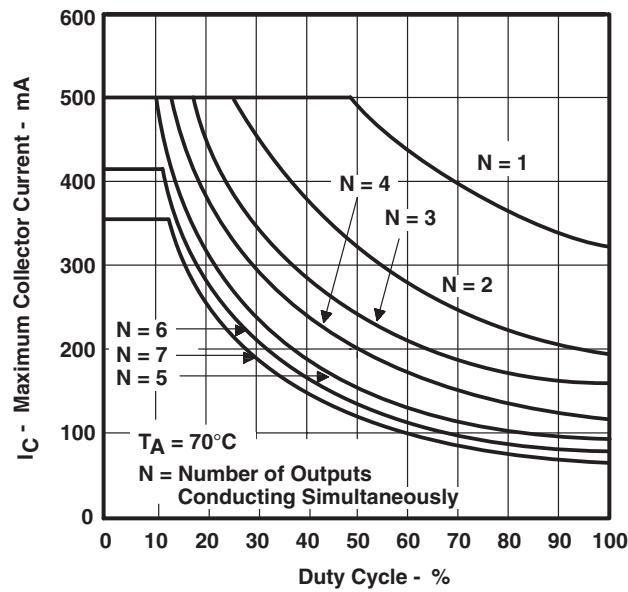

Figure 16. D Package Maximum Collector Current vs Duty Cycle

### 9.3 System Examples

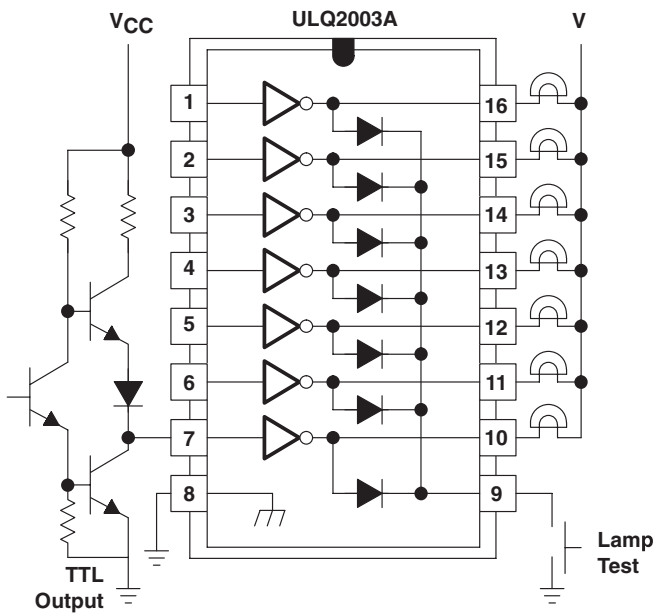

Figure 17. TTL to Load

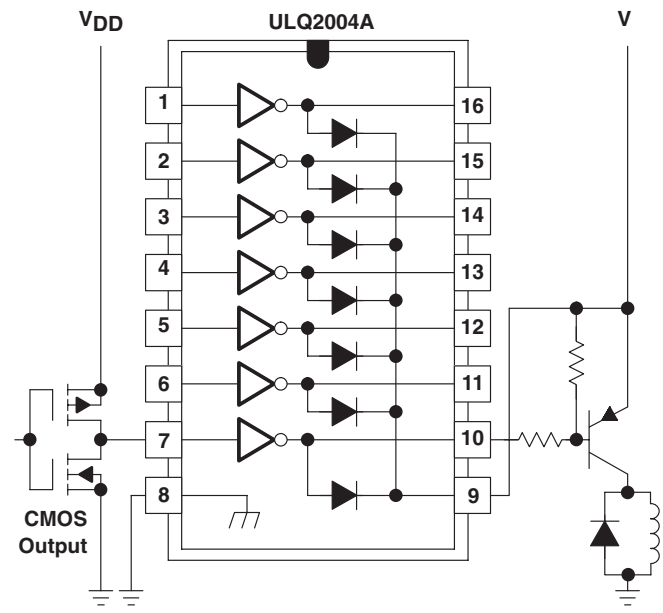

Figure 18. Buffer for Higher Current Loads

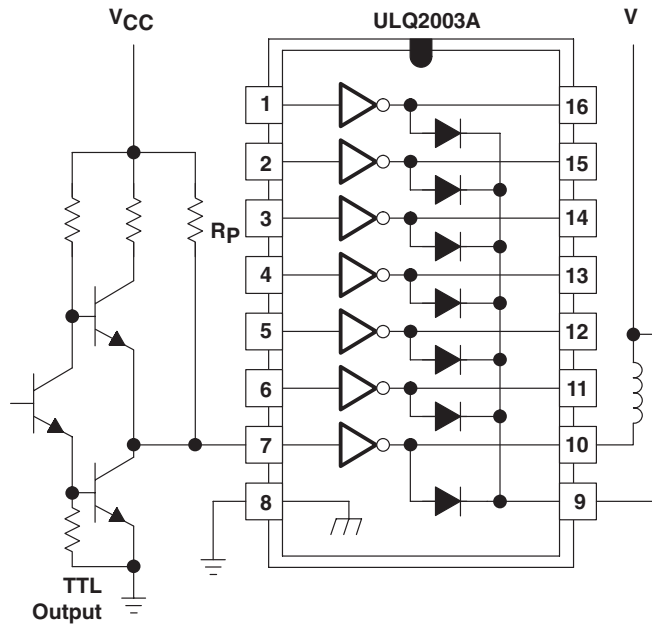

Figure 19. Use of Pullup Resistors to Increase Drive Current

## 10 Power Supply Recommendations

This device does not need a power supply. However, the COM pin is typically tied to the system power supply. When this is the case, it is very important to ensure that the output voltage does not heavily exceed the COM pin voltage. This discrepancy heavily forward biases the fly-back diodes and causes a large current to flow into COM, potentially damaging the on-chip metal or over-heating the device.

## 11 Layout

### 11.1 Layout Guidelines

Thin traces can be used on the input due to the low-current logic that is typically used to drive the ULQ200xA-Q1 devices. Take care to separate the input channels as much as possible, as to eliminate crosstalk. TI recommends thick traces for the output to drive whatever high currents that may be needed. Wire thickness can be determined by the current density of the trace material and desired drive current.

Because all of the channels currents return to a common emitter, it is best to size that trace width to be very wide. Some applications require up to 2.5 A.

### 11.2 Layout Example

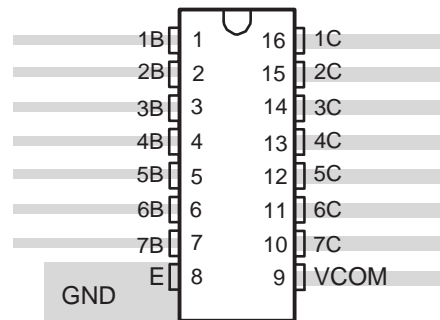

**Figure 20. Package Layout**

## 12 Device and Documentation Support

### 12.1 Related Links

The table below lists quick access links. Categories include technical documents, support and community resources, tools and software, and quick access to sample or buy.

**Table 2. Related Links**

PARTS	PRODUCT FOLDER	SAMPLE & BUY	TECHNICAL DOCUMENTS	TOOLS & SOFTWARE	SUPPORT & COMMUNITY
ULQ2003A-Q1	<a href="#">Click here</a>	<a href="#">Click here</a>	<a href="#">Click here</a>	<a href="#">Click here</a>	<a href="#">Click here</a>
ULQ2004A-Q1	<a href="#">Click here</a>	<a href="#">Click here</a>	<a href="#">Click here</a>	<a href="#">Click here</a>	<a href="#">Click here</a>

### 12.2 Community Resources

The following links connect to TI community resources. Linked contents are provided "AS IS" by the respective contributors. They do not constitute TI specifications and do not necessarily reflect TI's views; see TI's [Terms of Use](#).

**TI E2E™ Online Community** *TI's Engineer-to-Engineer (E2E) Community*. Created to foster collaboration among engineers. At [e2e.ti.com](http://e2e.ti.com), you can ask questions, share knowledge, explore ideas and help solve problems with fellow engineers.

**Design Support** *TI's Design Support* Quickly find helpful E2E forums along with design support tools and contact information for technical support.

### 12.3 Trademarks

E2E is a trademark of Texas Instruments.  
All other trademarks are the property of their respective owners.

### 12.4 Electrostatic Discharge Caution



These devices have limited built-in ESD protection. The leads should be shorted together or the device placed in conductive foam during storage or handling to prevent electrostatic damage to the MOS gates.

### 12.5 Glossary

**SLYZ022** — *TI Glossary*.

This glossary lists and explains terms, acronyms, and definitions.

## 13 Mechanical, Packaging, and Orderable Information

The following pages include mechanical, packaging, and orderable information. This information is the most current data available for the designated devices. This data is subject to change without notice and revision of this document. For browser-based versions of this data sheet, refer to the left-hand navigation.

**PACKAGING INFORMATION**

Orderable Device	Status (1)	Package Type	Package Drawing	Pins	Package Qty	Eco Plan (2)	Lead finish/ Ball material (6)	MSL Peak Temp (3)	Op Temp (°C)	Device Marking (4/5)	Samples
ULQ2003AQDRQ1	ACTIVE	SOIC	D	16	2500	RoHS & Green	NIPDAU	Level-1-260C-UNLIM	-40 to 125	ULQ2003AQ	<a href="#">Samples</a>
ULQ2003ATDG4Q1	ACTIVE	SOIC	D	16	40	RoHS & Green	NIPDAU	Level-1-260C-UNLIM	-40 to 105	ULQ2003AT	<a href="#">Samples</a>
ULQ2003ATDQ1	ACTIVE	SOIC	D	16	40	RoHS & Green	NIPDAU	Level-1-260C-UNLIM	-40 to 105	ULQ2003AT	<a href="#">Samples</a>
ULQ2003ATDRG4Q1	ACTIVE	SOIC	D	16	2500	RoHS & Green	NIPDAU	Level-1-260C-UNLIM	-40 to 105	ULQ2003AT	<a href="#">Samples</a>
ULQ2003ATDRQ1	ACTIVE	SOIC	D	16	2500	RoHS & Green	NIPDAU	Level-1-260C-UNLIM	-40 to 105	ULQ2003AT	<a href="#">Samples</a>
ULQ2003ATPWRQ1	ACTIVE	TSSOP	PW	16	2500	RoHS & Green	NIPDAU	Level-1-260C-UNLIM	-40 to 105	U2003AT	<a href="#">Samples</a>
ULQ2004ATDRG4Q1	ACTIVE	SOIC	D	16	2500	RoHS & Green	NIPDAU	Level-1-260C-UNLIM	-40 to 105	ULQ2004AT	<a href="#">Samples</a>
ULQ2004ATDRQ1	ACTIVE	SOIC	D	16	2500	RoHS & Green	NIPDAU	Level-1-260C-UNLIM	-40 to 105	ULQ2004AT	<a href="#">Samples</a>

(1) The marketing status values are defined as follows:

**ACTIVE:** Product device recommended for new designs.

**LIFEBUY:** TI has announced that the device will be discontinued, and a lifetime-buy period is in effect.

**NRND:** Not recommended for new designs. Device is in production to support existing customers, but TI does not recommend using this part in a new design.

**PREVIEW:** Device has been announced but is not in production. Samples may or may not be available.

**OBSELETE:** TI has discontinued the production of the device.

(2) **RoHS:** TI defines "RoHS" to mean semiconductor products that are compliant with the current EU RoHS requirements for all 10 RoHS substances, including the requirement that RoHS substance do not exceed 0.1% by weight in homogeneous materials. Where designed to be soldered at high temperatures, "RoHS" products are suitable for use in specified lead-free processes. TI may reference these types of products as "Pb-Free".

**RoHS Exempt:** TI defines "RoHS Exempt" to mean products that contain lead but are compliant with EU RoHS pursuant to a specific EU RoHS exemption.

**Green:** TI defines "Green" to mean the content of Chlorine (Cl) and Bromine (Br) based flame retardants meet JS709B low halogen requirements of <=1000ppm threshold. Antimony trioxide based flame retardants must also meet the <=1000ppm threshold requirement.

(3) MSL, Peak Temp. - The Moisture Sensitivity Level rating according to the JEDEC industry standard classifications, and peak solder temperature.

(4) There may be additional marking, which relates to the logo, the lot trace code information, or the environmental category on the device.

(5) Multiple Device Markings will be inside parentheses. Only one Device Marking contained in parentheses and separated by a "~" will appear on a device. If a line is indented then it is a continuation of the previous line and the two combined represent the entire Device Marking for that device.

<sup>(6)</sup> Lead finish/Ball material - Orderable Devices may have multiple material finish options. Finish options are separated by a vertical ruled line. Lead finish/Ball material values may wrap to two lines if the finish value exceeds the maximum column width.

**Important Information and Disclaimer:**The information provided on this page represents TI's knowledge and belief as of the date that it is provided. TI bases its knowledge and belief on information provided by third parties, and makes no representation or warranty as to the accuracy of such information. Efforts are underway to better integrate information from third parties. TI has taken and continues to take reasonable steps to provide representative and accurate information but may not have conducted destructive testing or chemical analysis on incoming materials and chemicals. TI and TI suppliers consider certain information to be proprietary, and thus CAS numbers and other limited information may not be available for release.

In no event shall TI's liability arising out of such information exceed the total purchase price of the TI part(s) at issue in this document sold by TI to Customer on an annual basis.

**OTHER QUALIFIED VERSIONS OF ULQ2003A-Q1, ULQ2004A-Q1 :**

- Catalog: [ULQ2003A](#), [ULQ2004A](#)

NOTE: Qualified Version Definitions:

- Catalog - TI's standard catalog product

**TAPE AND REEL INFORMATION**

**QUADRANT ASSIGNMENTS FOR PIN 1 ORIENTATION IN TAPE**

\*All dimensions are nominal

Device	Package Type	Package Drawing	Pins	SPQ	Reel Diameter (mm)	Reel Width W1 (mm)	A0 (mm)	B0 (mm)	K0 (mm)	P1 (mm)	W (mm)	Pin1 Quadrant
ULQ2003ATPWRQ1	TSSOP	PW	16	2500	330.0	12.4	6.9	5.6	1.6	8.0	12.0	Q1
ULQ2004ATDRQ1	SOIC	D	16	2500	330.0	16.4	6.5	10.3	2.1	8.0	16.0	Q1

**TAPE AND REEL BOX DIMENSIONS**

\*All dimensions are nominal

Device	Package Type	Package Drawing	Pins	SPQ	Length (mm)	Width (mm)	Height (mm)
ULQ2003ATPWRQ1	TSSOP	PW	16	2500	853.0	449.0	35.0
ULQ2004ATDRQ1	SOIC	D	16	2500	340.5	336.1	32.0

**TUBE**

\*All dimensions are nominal

Device	Package Name	Package Type	Pins	SPQ	L (mm)	W (mm)	T (μm)	B (mm)
ULQ2003ATDG4Q1	D	SOIC	16	40	506.6	8	3940	4.32
ULQ2003ATDG4Q1	D	SOIC	16	40	507	8	3940	4.32
ULQ2003ATDQ1	D	SOIC	16	40	507	8	3940	4.32
ULQ2003ATDQ1	D	SOIC	16	40	506.6	8	3940	4.32

D (R-PDSO-G16)

PLASTIC SMALL OUTLINE



4040047-6/M 06/11

- NOTES:
- A. All linear dimensions are in inches (millimeters).
  - B. This drawing is subject to change without notice.
  -  C. Body length does not include mold flash, protrusions, or gate burrs. Mold flash, protrusions, or gate burrs shall not exceed 0.006 (0,15) each side.
  -  D. Body width does not include interlead flash. Interlead flash shall not exceed 0.017 (0,43) each side.
  - E. Reference JEDEC MS-012 variation AC.

D (R-PDSO-G16)

PLASTIC SMALL OUTLINE



- NOTES:
- All linear dimensions are in millimeters.
  - This drawing is subject to change without notice.
  - Publication IPC-7351 is recommended for alternate designs.
  - Laser cutting apertures with trapezoidal walls and also rounding corners will offer better paste release. Customers should contact their board assembly site for stencil design recommendations. Refer to IPC-7525 for other stencil recommendations.
  - Customers should contact their board fabrication site for solder mask tolerances between and around signal pads.



4220204/A 02/2017

NOTES:

1. All linear dimensions are in millimeters. Any dimensions in parenthesis are for reference only. Dimensioning and tolerancing per ASME Y14.5M.
2. This drawing is subject to change without notice.
3. This dimension does not include mold flash, protrusions, or gate burrs. Mold flash, protrusions, or gate burrs shall not exceed 0.15 mm per side.
4. This dimension does not include interlead flash. Interlead flash shall not exceed 0.25 mm per side.
5. Reference JEDEC registration MO-153.

# EXAMPLE BOARD LAYOUT

PW0016A

TSSOP - 1.2 mm max height

SMALL OUTLINE PACKAGE



LAND PATTERN EXAMPLE  
EXPOSED METAL SHOWN  
SCALE: 10X



SOLDER MASK DETAILS

4220204/A 02/2017

NOTES: (continued)

- 6. Publication IPC-7351 may have alternate designs.
- 7. Solder mask tolerances between and around signal pads can vary based on board fabrication site.

# EXAMPLE STENCIL DESIGN

PW0016A

TSSOP - 1.2 mm max height

SMALL OUTLINE PACKAGE

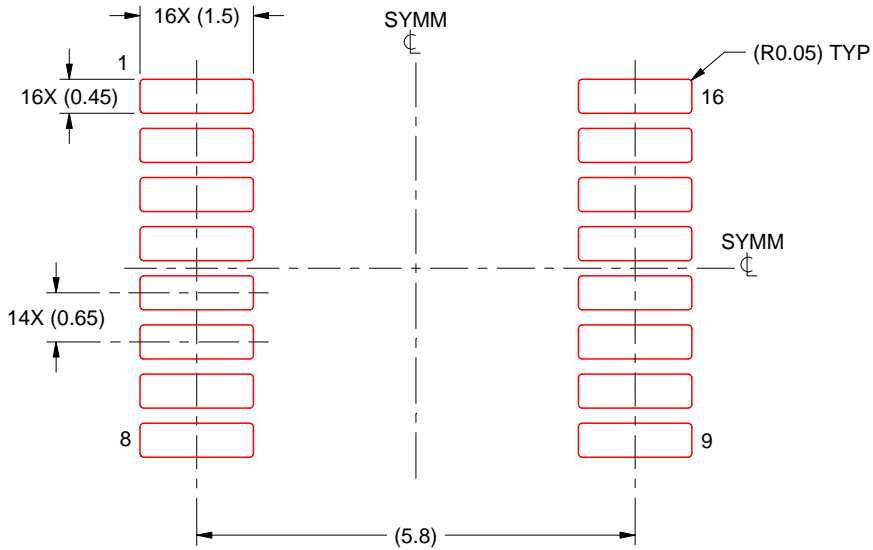

SOLDER PASTE EXAMPLE  
BASED ON 0.125 mm THICK STENCIL  
SCALE: 10X

4220204/A 02/2017

NOTES: (continued)

8. Laser cutting apertures with trapezoidal walls and rounded corners may offer better paste release. IPC-7525 may have alternate design recommendations.
9. Board assembly site may have different recommendations for stencil design.

## IMPORTANT NOTICE AND DISCLAIMER

TI PROVIDES TECHNICAL AND RELIABILITY DATA (INCLUDING DATA SHEETS), DESIGN RESOURCES (INCLUDING REFERENCE DESIGNS), APPLICATION OR OTHER DESIGN ADVICE, WEB TOOLS, SAFETY INFORMATION, AND OTHER RESOURCES "AS IS" AND WITH ALL FAULTS, AND DISCLAIMS ALL WARRANTIES, EXPRESS AND IMPLIED, INCLUDING WITHOUT LIMITATION ANY IMPLIED WARRANTIES OF MERCHANTABILITY, FITNESS FOR A PARTICULAR PURPOSE OR NON-INFRINGEMENT OF THIRD PARTY INTELLECTUAL PROPERTY RIGHTS.

These resources are intended for skilled developers designing with TI products. You are solely responsible for (1) selecting the appropriate TI products for your application, (2) designing, validating and testing your application, and (3) ensuring your application meets applicable standards, and any other safety, security, regulatory or other requirements.

These resources are subject to change without notice. TI grants you permission to use these resources only for development of an application that uses the TI products described in the resource. Other reproduction and display of these resources is prohibited. No license is granted to any other TI intellectual property right or to any third party intellectual property right. TI disclaims responsibility for, and you will fully indemnify TI and its representatives against, any claims, damages, costs, losses, and liabilities arising out of your use of these resources.

TI's products are provided subject to [TI's Terms of Sale](#) or other applicable terms available either on [ti.com](http://ti.com) or provided in conjunction with such TI products. TI's provision of these resources does not expand or otherwise alter TI's applicable warranties or warranty disclaimers for TI products.

TI objects to and rejects any additional or different terms you may have proposed.

Mailing Address: Texas Instruments, Post Office Box 655303, Dallas, Texas 75265  
Copyright © 2022, Texas Instruments Incorporated