

## SNx4AHCT245 具有三态输出的八路总线收发器

### 1 特性

- 输入兼容 TTL 电压
- 闩锁性能超过 250mA，符合 JESD 17 规范
- 对于符合 MIL-PRF-38535 标准的产品，所有参数均经过测试，除非另外注明。对于所有其他产品，生产流程不一定包含对所有参数的测试。

### 2 应用

- 启用或禁用数字信号
- 在控制器复位期间保持信号
- 对开关进行去抖

### 3 说明

SNx4AHCT245 八路总线收发器专为数据总线之间的异步双向通信而设计。这些器件的工作电压范围为 4.5V 至 5.5V。

#### 封装信息<sup>(1)</sup>

器件型号	封装	封装尺寸 (标称值)
SN54AHCT245	J (CDIP, 20)	24.2mm × 6.92mm
	W (CFP, 20)	13.09mm × 6.92mm
	FK (LCCC, 20)	8.89mm × 8.89mm
SN74AHCT245	RGY (VQFN, 20)	4.50mm × 3.50mm
	N (PDIP, 20)	25.40mm × 6.35mm
	NS (SOP, 20)	12.60mm × 5.30mm
	DB (SSOP, 20)	7.50mm × 5.30mm
	DGV (TVSOP, 20)	5.00mm × 4.40mm
	DW (SOIC, 20)	12.80mm × 7.50mm
	PW (TSSOP, 20)	6.50mm × 4.40mm
	RKS (VQFN, 20)	4.50mm × 2.50mm
DGS (VSSOP, 20)	5.10mm × 3.00mm	

(1) 如需了解所有可用封装，请参阅数据表末尾的可订购产品附录。

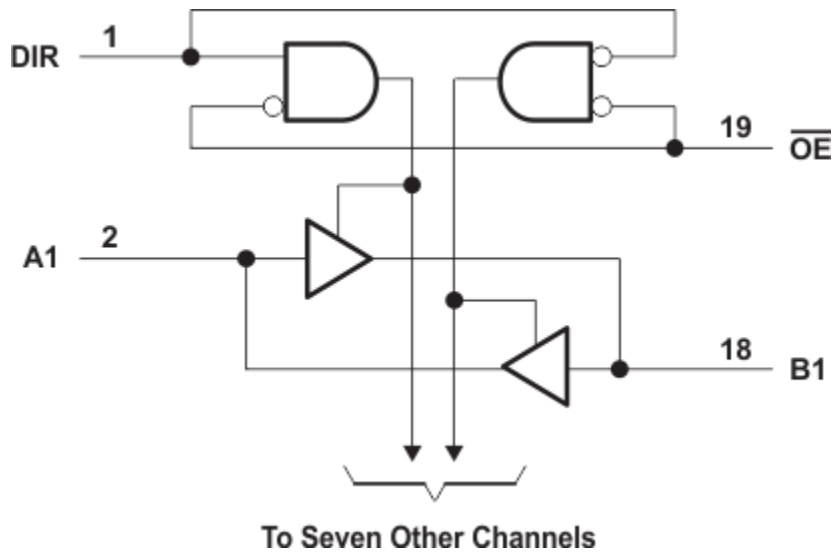

简化原理图



## Table of Contents

<b>1 特性</b> .....	1	8.2 Functional Block Diagram.....	9
<b>2 应用</b> .....	1	8.3 Feature Description.....	9
<b>3 说明</b> .....	1	8.4 Device Functional Modes.....	9
<b>5 Pin Configuration and Functions</b> .....	3	<b>9 Application and Implementation</b> .....	10
<b>6 Specifications</b> .....	4	9.1 Application Information.....	10
6.1 Absolute Maximum Ratings.....	4	9.2 Typical Application.....	10
6.2 ESD Ratings.....	4	9.3 Power Supply Recommendations.....	11
6.3 Recommended Operating Conditions.....	4	9.4 Layout.....	11
6.4 Thermal Information.....	5	<b>10 Device and Documentation Support</b> .....	12
6.5 Electrical Characteristics.....	5	10.1 接收文档更新通知.....	12
6.6 Switching Characteristics.....	6	10.2 支持资源.....	12
6.7 Noise Characteristics.....	6	10.3 Trademarks.....	12
6.8 Operating Characteristics.....	6	10.4 静电放电警告.....	12
6.9 Typical Characteristics.....	7	10.5 术语表.....	12
<b>7 Parameter Measurement Information</b> .....	8	<b>11 Mechanical, Packaging, and Orderable Information</b> .....	12
<b>8 Detailed Description</b> .....	9		
8.1 Overview.....	9		

## 4

注：以前版本的页码可能与当前版本的页码不同

### Changes from Revision R (April 2023) to Revision S (July 2023) Page

- Updated  $R_{\theta JA}$  values: DB = 96.0 to 113.1, DW = 79.8 to 96.2, PW = 102.8 to 122.3; Updated DB, DW, and PW packages for  $R_{\theta JC(top)}$ ,  $R_{\theta JB}$ ,  $\Psi_{JT}$ ,  $\Psi_{JB}$ , and  $R_{\theta JC(bot)}$ , all values in °C/W.....5

### Changes from Revision Q (December 2022) to Revision R (April 2023) Page

- 更新了“应用”部分.....1
- 向“封装信息”表、“引脚配置和功能”以及“热性能信息”添加了 DGS 封装信息.....1
- 更新了“封装信息”表.....1

### Changes from Revision P (July 2014) to Revision Q (December 2022) Page

- 向“封装信息”表、“引脚配置和功能”以及“热性能信息”添加了 RKS 封装信息.....1

## 5 Pin Configuration and Functions



图 5-1. SN54AHCT245: J or W SN74AHCT245: DB, DGV, DW, N, NS, PW or DGS Package, 20-Pin CDIP, CFP, SSOP, TVSOP, SOIC, PDIP, SOP, TSSOP, or VSSOP (Top View)



图 5-2. SN74AHCT245: RGY or RKS Package, 20-Pin VQFN (Top View)

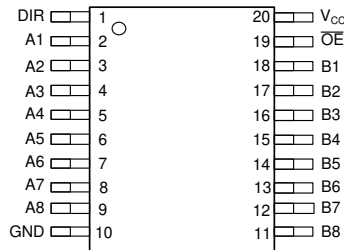

图 5-3. SN54AHCT245: FK Package, 20-Pin LCCC (Top View)

表 5-1. Pin Functions

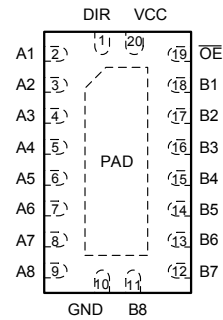
PIN		TYPE <sup>(1)</sup>	DESCRIPTION
NAME	NO.		
DIR	1	I	Direction Pin
A1	2	I/O	A1 Input/Output
A2	3	I/O	A2 Input/Output
A3	4	I/O	A3 Input/Output
A4	5	I/O	A4 Input/Output
A5	6	I/O	A5 Input/Output
A6	7	I/O	A6 Input/Output
A7	8	I/O	A7 Input/Output
A8	9	I/O	A8 Input/Output
GND	10	G	Ground Pin
B8	11	I/O	B8 Input/Output
B7	12	I/O	B7 Input/Output
B6	13	I/O	B6 Input/Output
B5	14	I/O	B5 Input/Output
B4	15	I/O	B4 Input/Output
B3	16	I/O	B3 Input/Output
B2	17	I/O	B2 Input/Output
B1	18	I/O	B1 Input/Output
OE	19	I	Output Enable
VCC	20	P	Power Pin

(1) I = Input, O = Output, P = Positive Supply, G = Ground

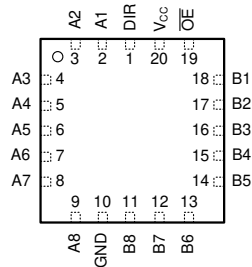
## 6 Specifications

### 6.1 Absolute Maximum Ratings

over operating free-air temperature range (unless otherwise noted)<sup>(1)</sup>

			MIN	MAX	UNIT
V <sub>CC</sub>	Supply voltage range		- 0.5	7	V
V <sub>I</sub>	Input voltage range <sup>(2)</sup>	Control inputs	- 0.5	7	V
V <sub>O</sub>	Output voltage range <sup>(2)</sup>		- 0.5	V <sub>CC</sub> + 0.5	V
I <sub>IK</sub>	Input clamp current	V <sub>I</sub> < 0		- 20	mA
I <sub>OK</sub>	Output clamp current	V <sub>O</sub> < 0 or V <sub>O</sub> > V <sub>CC</sub>		±20	mA
I <sub>O</sub>	Continuous output current	V <sub>O</sub> = 0 to V <sub>CC</sub>		±25	mA
Continuous current through V <sub>CC</sub> or GND				±75	mA
T <sub>stg</sub>	Storage temperature		-65	150	°C

- (1) Operation outside the *Absolute Maximum Rating* may cause permanent device damage. *Absolute Maximum Rating* do not imply functional operation of the device at these or any other conditions beyond those listed under *Recommended Operating Condition*. If used outside the *Recommended Operating Condition* but within the *Absolute Maximum Rating*, the device may not be fully functional, and this may affect device reliability, functionality, performance, and shorten the device lifetime.
- (2) The input and output voltage ratings may be exceeded if the input and output current ratings are observed.

### 6.2 ESD Ratings

			MIN	MAX	UNIT
V <sub>(ESD)</sub>	Electrostatic discharge	Human body model (HBM), per ANSI/ESDA/JEDEC JS-001 <sup>(1)</sup>		±2000	V
		Charged-device model (CDM), per ANSI/ESDA/JEDEC JS-002 <sup>(2)</sup>		±1000	

- (1) JEDEC document JEP155 states that 500-V HBM allows safe manufacturing with a standard ESD control process.
- (2) JEDEC document JEP157 states that 250-V CDM allows safe manufacturing with a standard ESD control process.

### 6.3 Recommended Operating Conditions

over operating free-air temperature range (unless otherwise noted)<sup>(1)</sup>

		SN54AHCT245		SN74AHCT245		UNIT
		MIN	MAX	MIN	MAX	
V <sub>CC</sub>	Supply voltage	4.5	5.5	4.5	5.5	V
V <sub>IH</sub>	High-level input voltage	2		2		V
V <sub>IL</sub>	Low-level Input voltage		0.8		0.8	V
V <sub>I</sub>	Input voltage	0	5.5	0	5.5	V
V <sub>O</sub>	Output voltage	0	V <sub>CC</sub>	0	V <sub>CC</sub>	V
I <sub>OH</sub>	High-level output current		- 8		- 8	mA
I <sub>OL</sub>	Low-level output current		8		8	mA
Δt/Δv	Input Transition rise and fall rate		20		20	ns/V
T <sub>A</sub>	Operating free-air temperature	- 55	125	- 40	125	°C

- (1) All unused inputs of the device must be held at V<sub>CC</sub> or GND for proper device operation. Refer to the TI application report, *Implications of Slow or Floating CMOS Inputs*, literature number [SCBA004](#).

## 6.4 Thermal Information

THERMAL METRIC <sup>(1)</sup>		SN74AHCT245									UNIT
		DB	DGV	DW	N	NS	PW	RGY	RKS	DGS	
		20 PINS									
$R_{\theta JA}$	Junction-to-ambient thermal resistance	113.1	116.1	96.2	51.5	77.1	122.3	35.1	67.7	118.4	°C/W
$R_{\theta JC(top)}$	Junction-to-case (top) thermal resistance	72.9	31.3	63.6	38.2	43.6	64.8	43.3	72.4	57.7	
$R_{\theta JB}$	Junction-to-board thermal resistance	67.9	57.6	64.7	32.4	44.6	73.3	12.9	40.4	73.1	
$\psi_{JT}$	Junction-to-top characterization parameter	39.3	1.0	40.5	24.6	17.2	19	0.9	10.3	5.7	
$\psi_{JB}$	Junction-to-board characterization parameter	67.5	56.9	64.3	32.3	44.2	73	12.9	40.4	72.7	
$R_{\theta JC(bot)}$	Junction-to-case (bottom) thermal resistance	n/a	n/a	n/a	n/a	n/a	n/a	7.9	24.1	n/a	

(1) For more information about traditional and new thermal metrics, see the *IC Package Thermal Metrics* application report, [SPRA953](#).

## 6.5 Electrical Characteristics

over recommended operating free-air temperature range (unless otherwise noted)

PARAMETER	TEST CONDITIONS	$V_{CC}$	$T_A = 25^\circ\text{C}$			SN54AHCT245	SN74AHCT245	Recommended		UNIT
			MIN	TYP	MAX	- 55°C TO 125°C	- 40°C TO 85°C	SN74AHCT245 - 40°C TO 125°C		
$V_{OH}$	$I_{OH} = -50 \mu\text{A}$	4.5 V	4.4	4.5		4.4	4.4	4.4		V
	$I_{OH} = -8 \text{ mA}$		3.94			3.8	3.8	3.7		
$V_{OL}$	$I_{OL} = 50 \mu\text{A}$	4.5 V			0.1		0.1	0.1		V
	$I_{OH} = 8 \text{ mA}$				0.36		0.44	0.44		
$I_I$	$\overline{OE}$ or DIR	$V_I = 5.5 \text{ V}$ or GND			$\pm 0.1$		$\pm 1^{(1)}$	$\pm 1$		$\mu\text{A}$
$I_{OZ}$	A or B inputs <sup>(2)</sup>	$V_O = V_{CC}$ or GND			$\pm 25$		$\pm 2.5$	$\pm 2.5$		$\mu\text{A}$
$I_{CC}$		$V_I = V_{CC}$ or GND, $I_O = 0$			4		40	40		$\mu\text{A}$
$\Delta I_{CC}^{(3)}$		One input at 3.4 V, Other inputs at $V_{CC}$ or GND			1.35		1.5	1.5		mA
$C_i$	$\overline{OE}$ or DIR	$V_I = V_{CC}$ or GND		2.5	10			10		pF
$C_{io}$	A or B inputs	$V_I = V_{CC}$ or GND		4						pF

(1) On products compliant to MIL-PRF-38535, this parameter is not production tested at  $V_{CC} = 0 \text{ V}$ .

(2) For I/O ports, the parameter  $I_{OZ}$  includes the input leakage current.

(3) This is the increase in supply current for each input at one of the specified TTL voltage levels, rather than 0 V or  $V_{CC}$ .

## 6.6 Switching Characteristics

over recommended operating free-air temperature range,  $V_{CC} = 5 V \pm 0.5 V$  (unless otherwise noted) (see (1))

PARAMETER	FROM (INPUT)	TO (OUTPUT)	LOAD CAPACITANCE	$T_A = 25^\circ C$		SN54AHCT245 - 55°C TO 125°C		SN74AHCT245 - 40°C TO 85°C		Recommended SN74AHCT245 - 40°C TO 125°C		UNIT
				TYP	MAX	MIN	MAX	MIN	MAX	MIN	MAX	
$t_{PLH}$	A or B	B or A	$C_L = 15 \text{ pF}$	4.5 <sup>(1)</sup>	7.7 <sup>(1)</sup>	1 <sup>(1)</sup>	10 <sup>(1)</sup>	1	8.5	1	10	ns
$t_{PHL}$				4.5 <sup>(1)</sup>	7.7 <sup>(1)</sup>	1 <sup>(1)</sup>	10 <sup>(1)</sup>	1	8.5	1	10	
$t_{PZH}$	$\overline{OE}$	A or B	$C_L = 15 \text{ pF}$	8.9 <sup>(1)</sup>	13.8 <sup>(1)</sup>	1 <sup>(1)</sup>	16 <sup>(1)</sup>	1	15	1	16	ns
$t_{PZL}$				8.9 <sup>(1)</sup>	13.8 <sup>(1)</sup>	1 <sup>(1)</sup>	16 <sup>(1)</sup>	1	15	1	16	
$t_{PHZ}$	$\overline{OE}$	A or B	$C_L = 15 \text{ pF}$	9.2 <sup>(1)</sup>	14.4 <sup>(1)</sup>	1 <sup>(1)</sup>	16.5 <sup>(1)</sup>	1	15.5	1	16.5	ns
$t_{PLZ}$				9.2 <sup>(1)</sup>	14.4 <sup>(1)</sup>	1 <sup>(1)</sup>	16.5 <sup>(1)</sup>	1	15.5	1	16.5	
$t_{PLH}$	A or B	B or A	$C_L = 50 \text{ pF}$	5.3	8.7	1	11	1	9.5	1	11	ns
$t_{PHL}$				5.3	8.7	1	11	1	9.5	1	11	
$t_{PZH}$	$\overline{OE}$	A or B	$C_L = 50 \text{ pF}$	9.7	14.8	1	17	1	16	1	17	ns
$t_{PZL}$				9.7	14.8	1	17	1	16	1	17	
$t_{PHZ}$	$\overline{OE}$	A or B	$C_L = 50 \text{ pF}$	10	15.4	1	17.5	1	16.5	1	17.5	ns
$t_{PLZ}$				10	15.4	1	17.5	1	16.5	1	17.5	
$t_{sk(o)}$			$C_L = 50 \text{ pF}$		1 <sup>(2)</sup>				1			ns

(1) On products compliant to MIL-PRF-38535, this parameter is not production tested.

(2) On products compliant to MIL-PRF-38535, this parameter does not apply.

## 6.7 Noise Characteristics

$V_{CC} = 5 V$ ,  $C_L = 50 \text{ pF}$ ,  $T_A = 25^\circ C$ <sup>(1)</sup>

PARAMETER		SNx4AHCT245			UNIT
		MIN	TYP	MAX	
$V_{OH(V)}$	Quiet output, minimum dynamic $V_{OH}$		4		V
$V_{IH(D)}$	High-level dynamic input voltage		2		V
$V_{IL(D)}$	Low-level dynamic input voltage			0.8	V

(1) Characteristics are for surface-mount packages only.

## 6.8 Operating Characteristics

$V_{CC} = 5 V$ ,  $T_A = 25^\circ C$

PARAMETER	TEST CONDITIONS	TYP	UNIT
$C_{pd}$	Power dissipation capacitance No load, $f = 1 \text{ MHz}$	13	pF

## 6.9 Typical Characteristics



图 6-1. SNx4AHCT245 TPD vs Temperature, 15 pF Load

## 7 Parameter Measurement Information

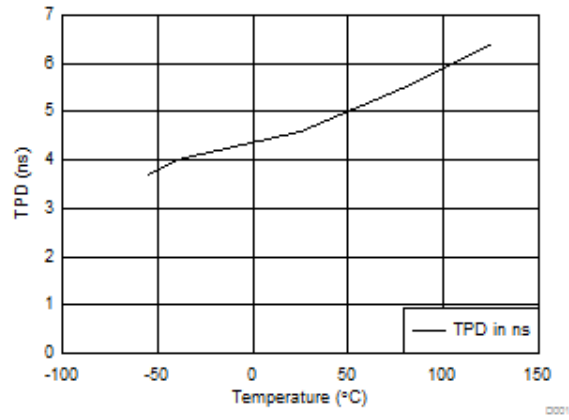
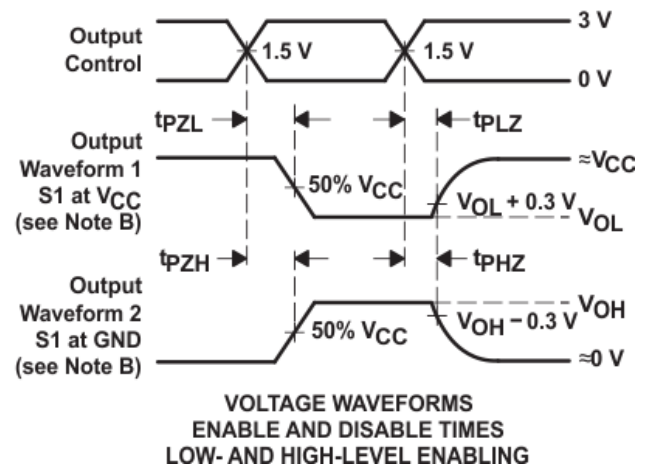
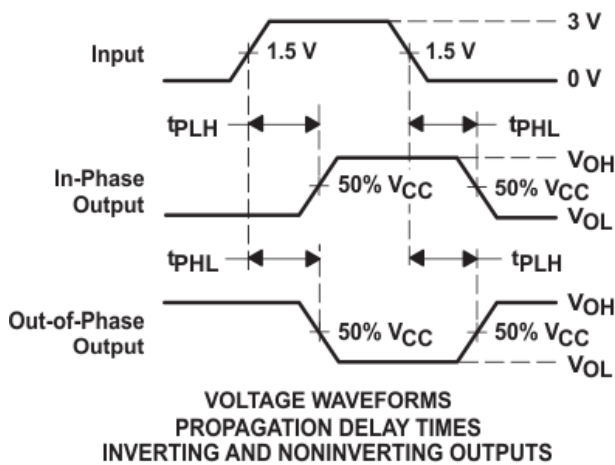
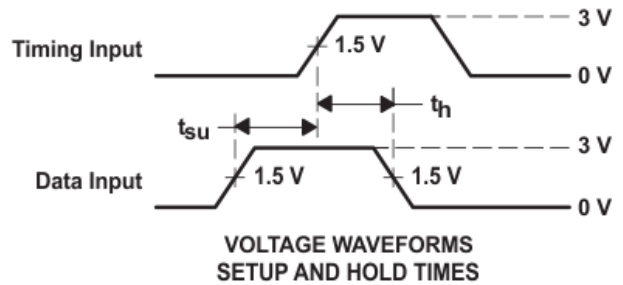
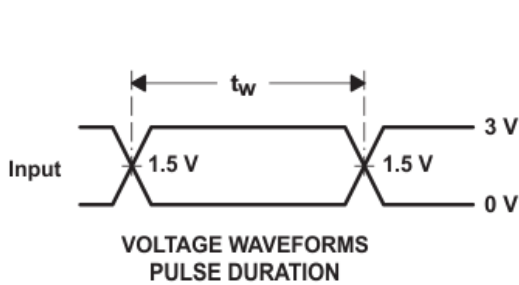
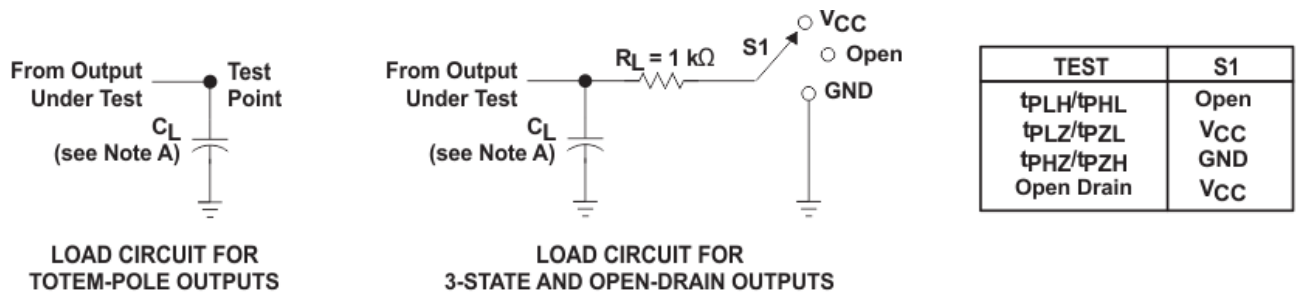

- A.  $C_L$  includes probe and jig capacitance.
- B. Waveform 1 is for an output with internal conditions such that the output is low except when disabled by the output control. Waveform 2 is for an output with internal conditions such that the output is high except when disabled by the output control.
- C. All input pulses are supplied by generators having the following characteristics:  $PRR \leq 1\text{ MHz}$ ,  $Z_O = 50\ \Omega$ ,  $t_r \leq 3\text{ ns}$ ,  $t_f \leq 3\text{ ns}$ .
- D. The outputs are measured one at a time with one input transition per measurement.
- E. All parameters and waveforms are not applicable to all devices.

图 7-1. Load Circuit and Voltage Waveforms

## 8 Detailed Description

### 8.1 Overview

The SNx7AHT245 octal bus transceivers are designed for asynchronous two-way communication between data buses. The control-function implementation minimizes external timing requirements. The SNx4AHT245 devices allow data transmission from the A bus to the B bus or from the B bus to the A bus, depending on the logic level at the direction - control (DIR) input. The output-enable ( $\overline{OE}$ ) input can be used to disable the device so that the buses effectively are isolated. For the high-impedance state during power up or power down,  $\overline{OE}$  should be tied to  $V_{CC}$  through a pullup resistor; the minimum value of the resistor is determined by the current-sinking capability of the driver.

### 8.2 Functional Block Diagram



图 8-1. Logic Diagram (Positive Logic)

### 8.3 Feature Description

- $V_{CC}$  is optimized at 5 V
- Allows up voltage translation from 3.3 V to 5 V
  - Inputs accept  $V_{IH}$  levels of 2 V
- Slow edge rates minimize output ringing

### 8.4 Device Functional Modes

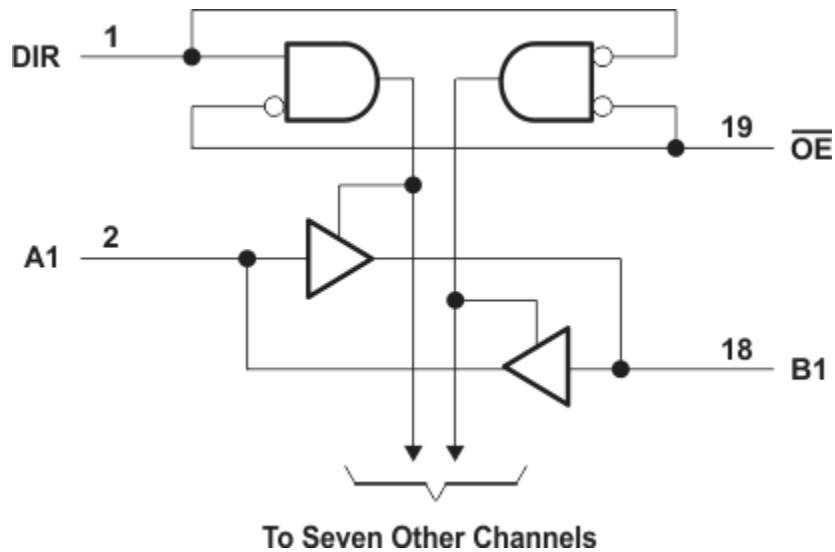
表 8-1. Function Table  
(Each Transceiver)

INPUTS		OPERATION
$\overline{OE}$	DIR	
L	L	B data to A bus
L	H	A data to B bus
H	X	Isolation

## 9 Application and Implementation

### 备注

以下应用部分中的信息不属于 TI 器件规格的范围，TI 不担保其准确性和完整性。TI 的客户应负责确定器件是否适用于其应用。客户应验证并测试其设计，以确保系统功能。

### 9.1 Application Information

The SN74AHCT245 is a low drive CMOS device that can be used for a multitude of bus interface type applications where output ringing is a concern. The low drive and slow edge rates will minimize overshoot and undershoot on the outputs. The input switching levels have been lowered to accommodate TTL inputs of  $0.8 V_{IL}$  and  $2 V_{IH}$ . This feature makes it ideal for translating up from 3.3 V to 5 V. The following figure shows this type of translation.

### 9.2 Typical Application



图 9-1. Typical Application Diagram

#### 9.2.1 Design Requirements

This device uses CMOS technology and has a balanced output drive. Take care to avoid bus contention, because it can drive currents that would exceed maximum limits. The high drive will also create fast edges into light loads so routing and load conditions should be considered to prevent ringing.

#### 9.2.2 Detailed Design Procedure

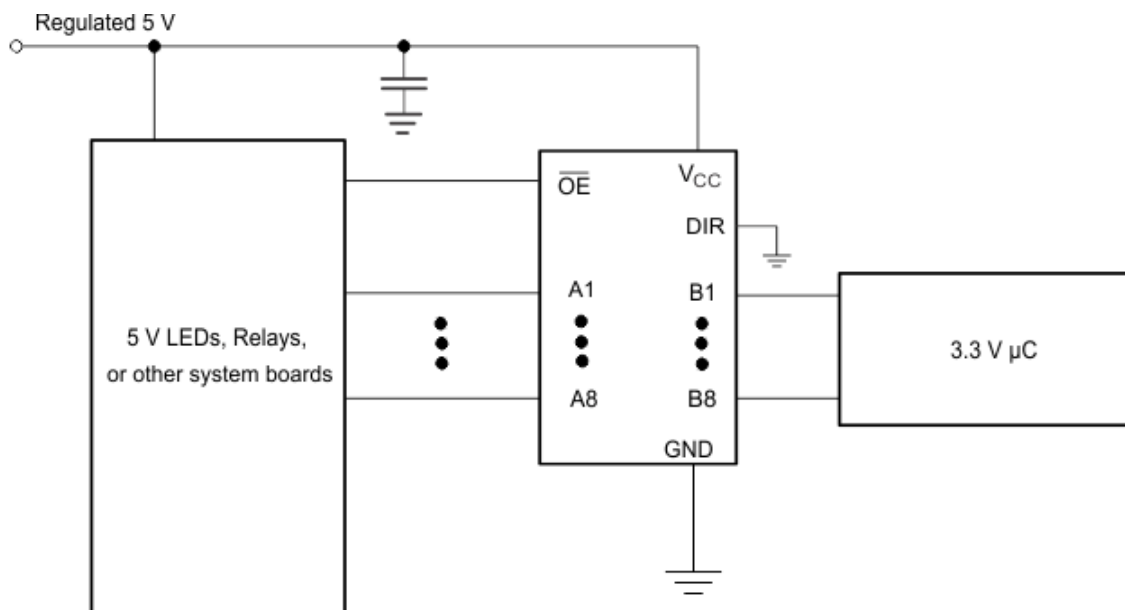
- Recommended input conditions:
  - Specified high and low levels. See ( $V_{IH}$  and  $V_{IL}$ ) in the [Recommended Operating Conditions](#) table.
  - Specified high and low levels. See ( $V_{IH}$  and  $V_{IL}$ ) in the [Recommended Operating Conditions](#) table.
  - Inputs are overvoltage tolerant allowing them to go as high as 5.5 V at any valid  $V_{CC}$ .
- Recommend output conditions:
  - Load currents should not exceed 25 mA per output and 50 mA total for the part.
  - Outputs should not be pulled above  $V_{CC}$ .

### 9.2.3 Application Curves

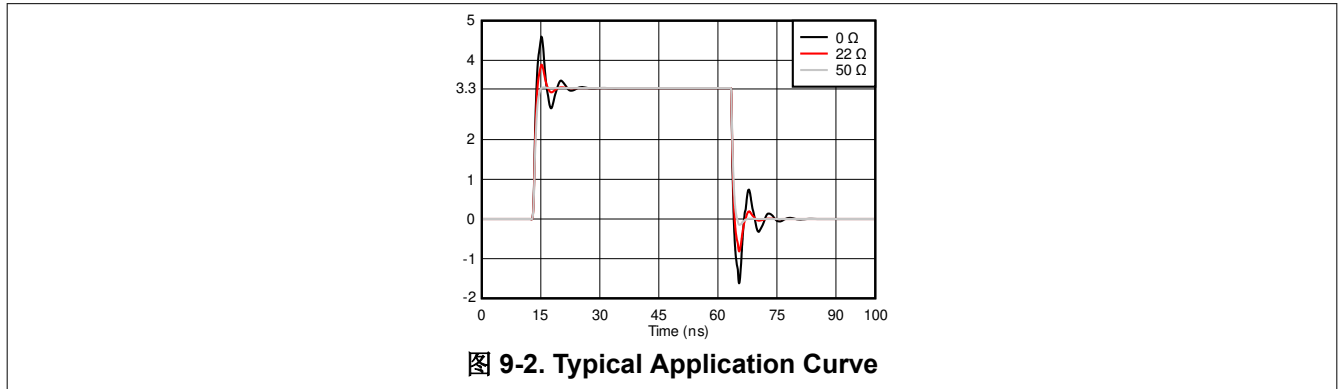

### 9.3 Power Supply Recommendations

The power supply can be any voltage between the MIN and MAX supply voltage rating located in the [Recommended Operating Conditions](#) table.

Each VCC pin should have a good bypass capacitor to prevent power disturbance. For devices with a single supply, 0.1  $\mu\text{f}$  is recommended; if there are multiple VCC pins, then 0.01  $\mu\text{f}$  or 0.022  $\mu\text{f}$  is recommended for each power pin. It is acceptable to parallel multiple bypass capacitors to reject different frequencies of noise. A 0.1  $\mu\text{f}$  and a 1  $\mu\text{f}$  are commonly used in parallel. The bypass capacitor should be installed as close to the power pin as possible for best results.

### 9.4 Layout

#### 9.4.1 Layout Guidelines

When using multiple-bit logic devices, inputs should never float.

In many cases, functions or parts of functions of digital logic devices are unused, for example, when only two inputs of a triple-input AND gate are used or only 3 of the 4 buffer gates are used. Such input pins should not be left unconnected because the undefined voltages at the outside connections result in undefined operational states. 图 9-3 specifies the rules that must be observed under all circumstances. All unused inputs of digital logic devices must be connected to a high or low bias to prevent them from floating. The logic level that should be applied to any particular unused input depends on the function of the device. Generally they will be tied to GND or  $V_{CC}$ , whichever makes more sense or is more convenient. It is generally acceptable to float outputs, unless the part is a transceiver. If the transceiver has an output enable pin, it will disable the output section of the part when asserted. This will not disable the input section of the I/Os, so they cannot float when disabled.

#### 9.4.2 Layout Example



图 9-3. Layout Diagram

## 10 Device and Documentation Support

### 10.1 接收文档更新通知

要接收文档更新通知，请导航至 [ti.com](http://ti.com) 上的器件产品文件夹。点击 [订阅更新](#) 进行注册，即可每周接收产品信息更改摘要。有关更改的详细信息，请查看任何已修订文档中包含的修订历史记录。

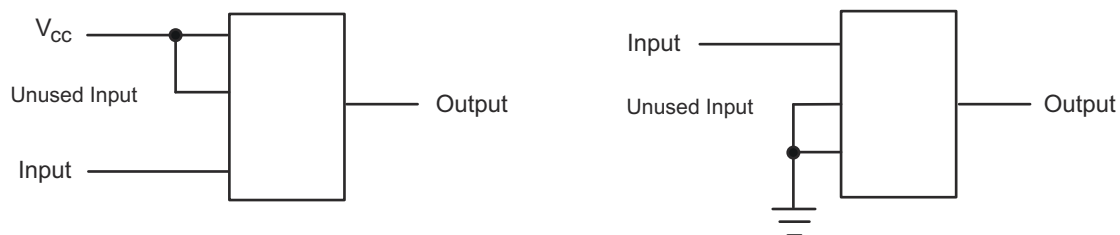
### 10.2 支持资源

TI E2E™ [支持论坛](#) 是工程师的重要参考资料，可直接从专家获得快速、经过验证的解答和设计帮助。搜索现有解答或提出自己的问题可获得所需的快速设计帮助。

链接的内容由各个贡献者“按原样”提供。这些内容并不构成 TI 技术规范，并且不一定反映 TI 的观点；请参阅 TI 的 [《使用条款》](#)。

### 10.3 Trademarks

TI E2E™ is a trademark of Texas Instruments.

所有商标均为其各自所有者的财产。

### 10.4 静电放电警告



静电放电 (ESD) 会损坏这个集成电路。德州仪器 (TI) 建议通过适当的预防措施处理所有集成电路。如果不遵守正确的处理和安装程序，可能会损坏集成电路。

ESD 的损坏小至导致微小的性能降级，大至整个器件故障。精密的集成电路可能更容易受到损坏，这是因为非常细微的参数更改都可能会导致器件与其发布的规格不相符。

### 10.5 术语表

[TI 术语表](#) 本术语表列出并解释了术语、首字母缩略词和定义。

## 11 Mechanical, Packaging, and Orderable Information

The following pages include mechanical, packaging, and orderable information. This information is the most current data available for the designated devices. This data is subject to change without notice and revision of this document. For browser-based versions of this data sheet, refer to the left-hand navigation.

**PACKAGING INFORMATION**

Orderable Device	Status (1)	Package Type	Package Drawing	Pins	Package Qty	Eco Plan (2)	Lead finish/ Ball material (6)	MSL Peak Temp (3)	Op Temp (°C)	Device Marking (4/5)	Samples
5962-9681901Q2A	ACTIVE	LCCC	FK	20	1	Non-RoHS & Green	SNPB	N / A for Pkg Type	-55 to 125	5962-9681901Q2A SNJ54AHCT245FK	<a href="#">Samples</a>
5962-9681901QRA	ACTIVE	CDIP	J	20	1	Non-RoHS & Green	SNPB	N / A for Pkg Type	-55 to 125	5962-9681901QR A SNJ54AHCT245J	<a href="#">Samples</a>
5962-9681901QSA	ACTIVE	CFP	W	20	1	Non-RoHS & Green	SNPB	N / A for Pkg Type	-55 to 125	5962-9681901QS A SNJ54AHCT245W	<a href="#">Samples</a>
SN74AHCT245DBR	ACTIVE	SSOP	DB	20	2000	RoHS & Green	NIPDAU	Level-1-260C-UNLIM	-40 to 125	HB245	<a href="#">Samples</a>
SN74AHCT245DBRG4	ACTIVE	SSOP	DB	20	2000	RoHS & Green	NIPDAU	Level-1-260C-UNLIM	-40 to 125	HB245	<a href="#">Samples</a>
SN74AHCT245DGSR	ACTIVE	VSSOP	DGS	20	5000	RoHS & Green	NIPDAU	Level-1-260C-UNLIM	-40 to 125	HB245	<a href="#">Samples</a>
SN74AHCT245DGVR	ACTIVE	TVSOP	DGV	20	2000	RoHS & Green	NIPDAU	Level-1-260C-UNLIM	-40 to 125	HB245	<a href="#">Samples</a>
SN74AHCT245DWR	ACTIVE	SOIC	DW	20	2000	RoHS & Green	NIPDAU	Level-1-260C-UNLIM	-40 to 125	AHCT245	<a href="#">Samples</a>
SN74AHCT245N	ACTIVE	PDIP	N	20	20	RoHS & Non-Green	NIPDAU	N / A for Pkg Type	-40 to 125	SN74AHCT245N	<a href="#">Samples</a>
SN74AHCT245NSR	ACTIVE	SO	NS	20	2000	RoHS & Green	NIPDAU	Level-1-260C-UNLIM	-40 to 125	AHCT245	<a href="#">Samples</a>
SN74AHCT245PWR	ACTIVE	TSSOP	PW	20	2000	RoHS & Green	NIPDAU   SN	Level-1-260C-UNLIM	-40 to 125	HB245	<a href="#">Samples</a>
SN74AHCT245PWRE4	ACTIVE	TSSOP	PW	20	2000	RoHS & Green	NIPDAU	Level-1-260C-UNLIM	-40 to 125	HB245	<a href="#">Samples</a>
SN74AHCT245PWRG3	ACTIVE	TSSOP	PW	20	2000	RoHS & Green	SN	Level-1-260C-UNLIM	-40 to 125	HB245	<a href="#">Samples</a>
SN74AHCT245PWRG4	ACTIVE	TSSOP	PW	20	2000	RoHS & Green	NIPDAU	Level-1-260C-UNLIM	-40 to 125	HB245	<a href="#">Samples</a>
SN74AHCT245RGYR	ACTIVE	VQFN	RGY	20	3000	RoHS & Green	NIPDAU	Level-2-260C-1 YEAR	-40 to 125	HB245	<a href="#">Samples</a>
SN74AHCT245RKSR	ACTIVE	VQFN	RKS	20	3000	RoHS & Green	NIPDAU	Level-1-260C-UNLIM	-40 to 125	AHCT245	<a href="#">Samples</a>
SNJ54AHCT245FK	ACTIVE	LCCC	FK	20	1	Non-RoHS & Green	SNPB	N / A for Pkg Type	-55 to 125	5962-9681901Q2A	<a href="#">Samples</a>

Orderable Device	Status (1)	Package Type	Package Drawing	Pins	Package Qty	Eco Plan (2)	Lead finish/ Ball material (6)	MSL Peak Temp (3)	Op Temp (°C)	Device Marking (4/5)	Samples
										SNJ54AHCT 245FK	
SNJ54AHCT245J	ACTIVE	CDIP	J	20	1	Non-RoHS & Green	SNPB	N / A for Pkg Type	-55 to 125	5962-9681901QR A SNJ54AHCT245J	Samples
SNJ54AHCT245W	ACTIVE	CFP	W	20	1	Non-RoHS & Green	SNPB	N / A for Pkg Type	-55 to 125	5962-9681901QS A SNJ54AHCT245W	Samples

(1) The marketing status values are defined as follows:

**ACTIVE:** Product device recommended for new designs.

**LIFEBUY:** TI has announced that the device will be discontinued, and a lifetime-buy period is in effect.

**NRND:** Not recommended for new designs. Device is in production to support existing customers, but TI does not recommend using this part in a new design.

**PREVIEW:** Device has been announced but is not in production. Samples may or may not be available.

**OBSOLETE:** TI has discontinued the production of the device.

(2) **RoHS:** TI defines "RoHS" to mean semiconductor products that are compliant with the current EU RoHS requirements for all 10 RoHS substances, including the requirement that RoHS substance do not exceed 0.1% by weight in homogeneous materials. Where designed to be soldered at high temperatures, "RoHS" products are suitable for use in specified lead-free processes. TI may reference these types of products as "Pb-Free".

**RoHS Exempt:** TI defines "RoHS Exempt" to mean products that contain lead but are compliant with EU RoHS pursuant to a specific EU RoHS exemption.

**Green:** TI defines "Green" to mean the content of Chlorine (Cl) and Bromine (Br) based flame retardants meet JS709B low halogen requirements of <=1000ppm threshold. Antimony trioxide based flame retardants must also meet the <=1000ppm threshold requirement.

(3) MSL, Peak Temp. - The Moisture Sensitivity Level rating according to the JEDEC industry standard classifications, and peak solder temperature.

(4) There may be additional marking, which relates to the logo, the lot trace code information, or the environmental category on the device.

(5) Multiple Device Markings will be inside parentheses. Only one Device Marking contained in parentheses and separated by a "~" will appear on a device. If a line is indented then it is a continuation of the previous line and the two combined represent the entire Device Marking for that device.

(6) Lead finish/Ball material - Orderable Devices may have multiple material finish options. Finish options are separated by a vertical ruled line. Lead finish/Ball material values may wrap to two lines if the finish value exceeds the maximum column width.

**Important Information and Disclaimer:**The information provided on this page represents TI's knowledge and belief as of the date that it is provided. TI bases its knowledge and belief on information provided by third parties, and makes no representation or warranty as to the accuracy of such information. Efforts are underway to better integrate information from third parties. TI has taken and continues to take reasonable steps to provide representative and accurate information but may not have conducted destructive testing or chemical analysis on incoming materials and chemicals. TI and TI suppliers consider certain information to be proprietary, and thus CAS numbers and other limited information may not be available for release.

In no event shall TI's liability arising out of such information exceed the total purchase price of the TI part(s) at issue in this document sold by TI to Customer on an annual basis.

**OTHER QUALIFIED VERSIONS OF SN54AHCT245, SN74AHCT245 :**

- Catalog : [SN74AHCT245](#)
- Automotive : [SN74AHCT245-Q1](#), [SN74AHCT245-Q1](#)
- Military : [SN54AHCT245](#)

NOTE: Qualified Version Definitions:

- Catalog - TI's standard catalog product
- Automotive - Q100 devices qualified for high-reliability automotive applications targeting zero defects
- Military - QML certified for Military and Defense Applications

**TAPE AND REEL INFORMATION**

**QUADRANT ASSIGNMENTS FOR PIN 1 ORIENTATION IN TAPE**

\*All dimensions are nominal

Device	Package Type	Package Drawing	Pins	SPQ	Reel Diameter (mm)	Reel Width W1 (mm)	A0 (mm)	B0 (mm)	K0 (mm)	P1 (mm)	W (mm)	Pin1 Quadrant
SN74AHCT245DBR	SSOP	DB	20	2000	330.0	16.4	8.2	7.5	2.5	12.0	16.0	Q1
SN74AHCT245DGSR	VSSOP	DGS	20	5000	330.0	16.4	5.4	5.4	1.45	8.0	16.0	Q1
SN74AHCT245DGVR	TVSOP	DGV	20	2000	330.0	12.4	6.9	5.6	1.6	8.0	12.0	Q1
SN74AHCT245DWR	SOIC	DW	20	2000	330.0	24.4	10.9	13.3	2.7	12.0	24.0	Q1
SN74AHCT245NSR	SO	NS	20	2000	330.0	24.4	8.4	13.0	2.5	12.0	24.0	Q1
SN74AHCT245PWR	TSSOP	PW	20	2000	330.0	16.4	6.95	7.0	1.4	8.0	16.0	Q1
SN74AHCT245PWRG3	TSSOP	PW	20	2000	330.0	16.4	6.95	7.1	1.6	8.0	16.0	Q1
SN74AHCT245PWRG4	TSSOP	PW	20	2000	330.0	16.4	6.95	7.0	1.4	8.0	16.0	Q1
SN74AHCT245RGYR	VQFN	RGY	20	3000	330.0	12.4	3.8	4.8	1.6	8.0	12.0	Q1
SN74AHCT245RKSR	VQFN	RKS	20	3000	180.0	12.4	2.8	4.8	1.2	4.0	12.0	Q1

**TAPE AND REEL BOX DIMENSIONS**

\*All dimensions are nominal

Device	Package Type	Package Drawing	Pins	SPQ	Length (mm)	Width (mm)	Height (mm)
SN74AHCT245DBR	SSOP	DB	20	2000	356.0	356.0	35.0
SN74AHCT245DGSR	VSSOP	DGS	20	5000	356.0	356.0	35.0
SN74AHCT245DGVR	TVSOP	DGV	20	2000	356.0	356.0	35.0
SN74AHCT245DWR	SOIC	DW	20	2000	367.0	367.0	45.0
SN74AHCT245NSR	SO	NS	20	2000	367.0	367.0	45.0
SN74AHCT245PWR	TSSOP	PW	20	2000	356.0	356.0	35.0
SN74AHCT245PWRG3	TSSOP	PW	20	2000	364.0	364.0	27.0
SN74AHCT245PWRG4	TSSOP	PW	20	2000	356.0	356.0	35.0
SN74AHCT245RGYR	VQFN	RGY	20	3000	356.0	356.0	35.0
SN74AHCT245RKSR	VQFN	RKS	20	3000	210.0	185.0	35.0

**TUBE**

\*All dimensions are nominal

Device	Package Name	Package Type	Pins	SPQ	L (mm)	W (mm)	T (μm)	B (mm)
5962-9681901Q2A	FK	LCCC	20	1	506.98	12.06	2030	NA
5962-9681901QSA	W	CFP	20	1	506.98	26.16	6220	NA
SN74AHCT245N	N	PDIP	20	20	506	13.97	11230	4.32
SNJ54AHCT245FK	FK	LCCC	20	1	506.98	12.06	2030	NA
SNJ54AHCT245W	W	CFP	20	1	506.98	26.16	6220	NA

W (R-GDFP-F20)

CERAMIC DUAL FLATPACK



- NOTES:
- A. All linear dimensions are in inches (millimeters).
  - B. This drawing is subject to change without notice.
  - C. This package can be hermetically sealed with a ceramic lid using glass frit.
  - D. Index point is provided on cap for terminal identification only.
  - E. Falls within Mil-Std 1835 GDFP2-F20

# PW0020A



# PACKAGE OUTLINE

## TSSOP - 1.2 mm max height

SMALL OUTLINE PACKAGE



4220206/A 02/2017

### NOTES:

1. All linear dimensions are in millimeters. Any dimensions in parenthesis are for reference only. Dimensioning and tolerancing per ASME Y14.5M.
2. This drawing is subject to change without notice.
3. This dimension does not include mold flash, protrusions, or gate burrs. Mold flash, protrusions, or gate burrs shall not exceed 0.15 mm per side.
4. This dimension does not include interlead flash. Interlead flash shall not exceed 0.25 mm per side.
5. Reference JEDEC registration MO-153.

# EXAMPLE BOARD LAYOUT

PW0020A

TSSOP - 1.2 mm max height

SMALL OUTLINE PACKAGE



LAND PATTERN EXAMPLE  
EXPOSED METAL SHOWN  
SCALE: 10X



SOLDER MASK DETAILS

4220206/A 02/2017

NOTES: (continued)

- 6. Publication IPC-7351 may have alternate designs.
- 7. Solder mask tolerances between and around signal pads can vary based on board fabrication site.

# EXAMPLE STENCIL DESIGN

PW0020A

TSSOP - 1.2 mm max height

SMALL OUTLINE PACKAGE



SOLDER PASTE EXAMPLE  
BASED ON 0.125 mm THICK STENCIL  
SCALE: 10X

4220206/A 02/2017

NOTES: (continued)

8. Laser cutting apertures with trapezoidal walls and rounded corners may offer better paste release. IPC-7525 may have alternate design recommendations.
9. Board assembly site may have different recommendations for stencil design.

PW (R-PDSO-G20)

PLASTIC SMALL OUTLINE

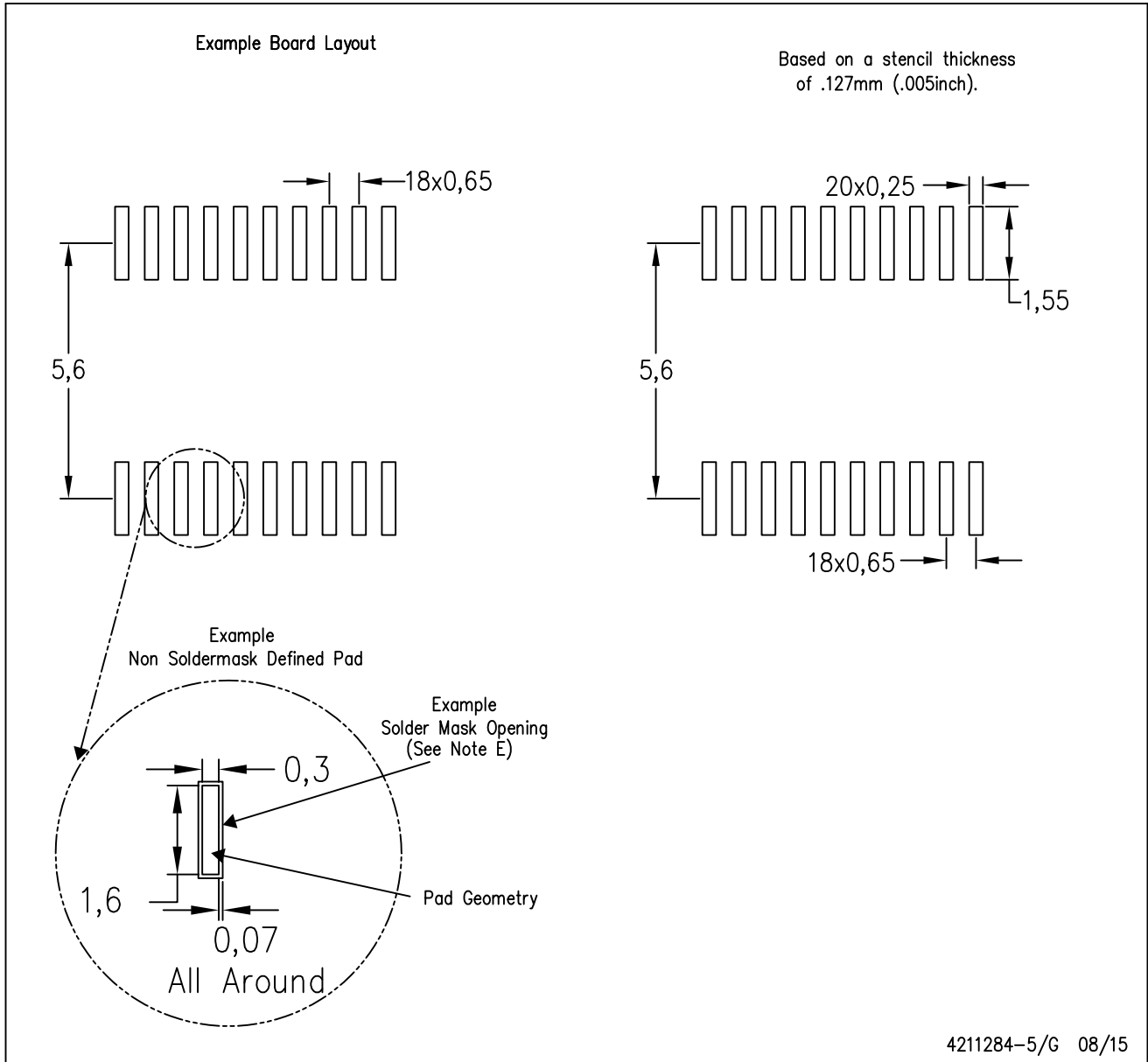

- NOTES:
- A. All linear dimensions are in millimeters.
  - B. This drawing is subject to change without notice.
  - C. Publication IPC-7351 is recommended for alternate design.
  - D. Laser cutting apertures with trapezoidal walls and also rounding corners will offer better paste release. Customers should contact their board assembly site for stencil design recommendations. Refer to IPC-7525 for other stencil recommendations.
  - E. Customers should contact their board fabrication site for solder mask tolerances between and around signal pads.

# DB0020A



# PACKAGE OUTLINE

## SSOP - 2 mm max height

SMALL OUTLINE PACKAGE



4214851/B 08/2019

### NOTES:

1. All linear dimensions are in millimeters. Any dimensions in parenthesis are for reference only. Dimensioning and tolerancing per ASME Y14.5M.
2. This drawing is subject to change without notice.
3. This dimension does not include mold flash, protrusions, or gate burrs. Mold flash, protrusions, or gate burrs shall not exceed 0.15 mm per side.
4. This dimension does not include interlead flash. Interlead flash shall not exceed 0.25 mm per side.
5. Reference JEDEC registration MO-150.

# EXAMPLE BOARD LAYOUT

DB0020A

SSOP - 2 mm max height

SMALL OUTLINE PACKAGE



LAND PATTERN EXAMPLE  
EXPOSED METAL SHOWN  
SCALE: 10X



4214851/B 08/2019

NOTES: (continued)

- 6. Publication IPC-7351 may have alternate designs.
- 7. Solder mask tolerances between and around signal pads can vary based on board fabrication site.

# EXAMPLE STENCIL DESIGN

DB0020A

SSOP - 2 mm max height

SMALL OUTLINE PACKAGE



SOLDER PASTE EXAMPLE  
BASED ON 0.125 mm THICK STENCIL  
SCALE: 10X

4214851/B 08/2019

NOTES: (continued)

8. Laser cutting apertures with trapezoidal walls and rounded corners may offer better paste release. IPC-7525 may have alternate design recommendations.
9. Board assembly site may have different recommendations for stencil design.

## GENERIC PACKAGE VIEW

**RKS 20**

**VQFN - 1 mm max height**

2.5 x 4.5, 0.5 mm pitch

PLASTIC QUAD FLATPACK - NO LEAD

This image is a representation of the package family, actual package may vary.  
Refer to the product data sheet for package details.

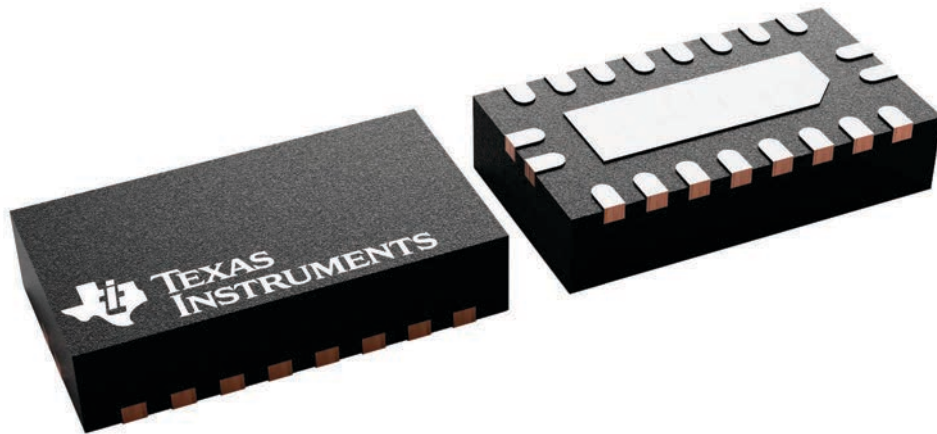

4226872/A



# EXAMPLE BOARD LAYOUT

RKS0020A

VQFN - 1 mm max height

PLASTIC QUAD FLATPACK - NO LEAD

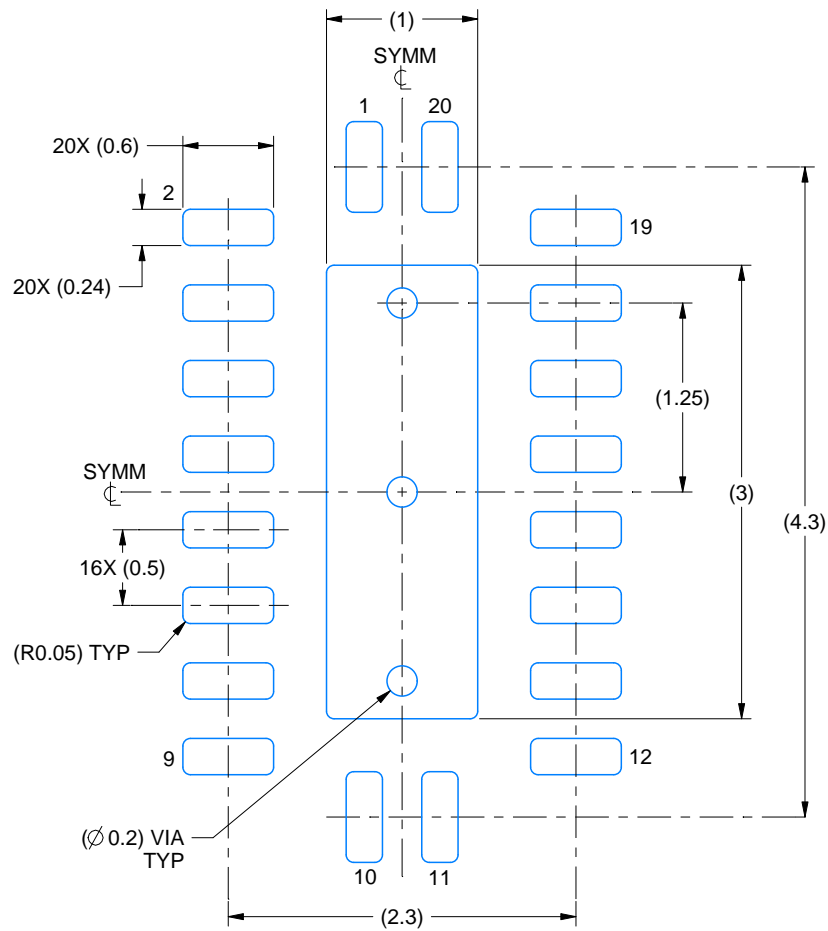

LAND PATTERN EXAMPLE  
SCALE:20X

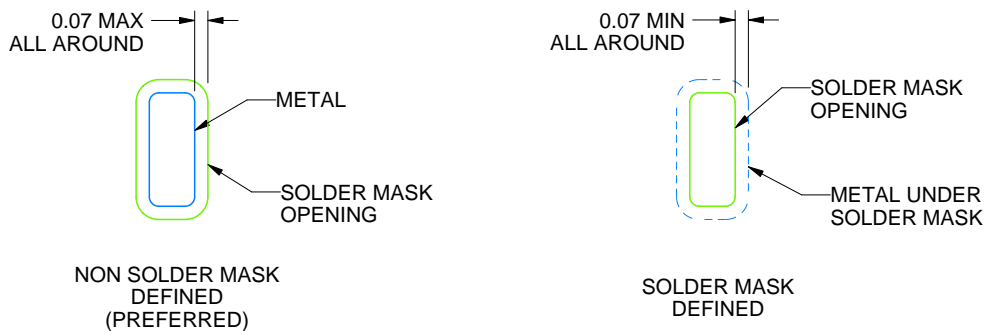

SOLDER MASK DETAILS

4222490/B 02/2021

NOTES: (continued)

- This package is designed to be soldered to a thermal pad on the board. For more information, see Texas Instruments literature number SLUA271 ([www.ti.com/lit/slua271](http://www.ti.com/lit/slua271)).
- Vias are optional depending on application, refer to device data sheet. If some or all are implemented, recommended via locations are shown.

# EXAMPLE STENCIL DESIGN

RKS0020A

VQFN - 1 mm max height

PLASTIC QUAD FLATPACK - NO LEAD

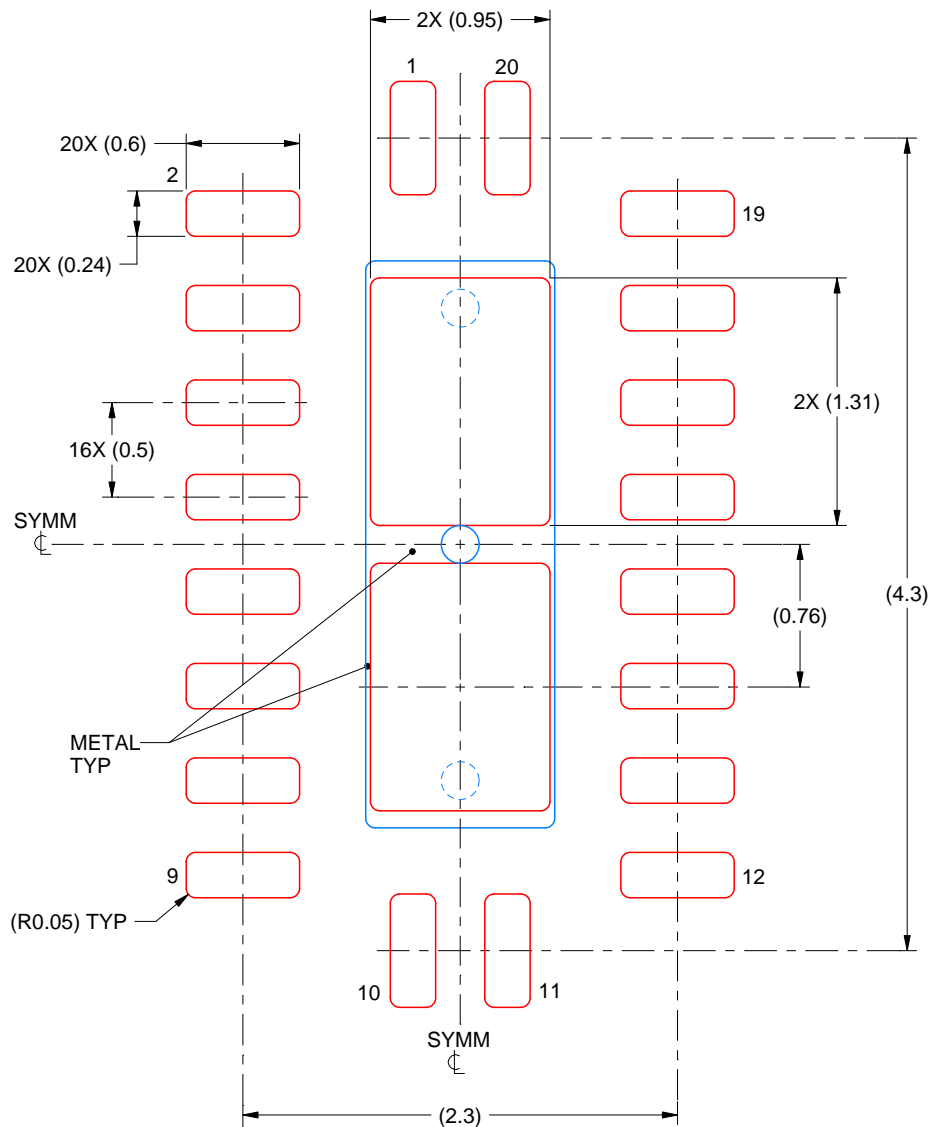

**SOLDER PASTE EXAMPLE**  
 BASED ON 0.125 mm THICK STENCIL

EXPOSED PAD  
 83% PRINTED SOLDER COVERAGE BY AREA  
 SCALE:25X

4222490/B 02/2021

NOTES: (continued)

6. Laser cutting apertures with trapezoidal walls and rounded corners may offer better paste release. IPC-7525 may have alternate design recommendations.

# MECHANICAL DATA

NS (R-PDSO-G\*\*)

PLASTIC SMALL-OUTLINE PACKAGE

14-PINS SHOWN



- NOTES:
- A. All linear dimensions are in millimeters.
  - B. This drawing is subject to change without notice.
  - C. Body dimensions do not include mold flash or protrusion, not to exceed 0,15.

J (R-GDIP-T\*\*)

14 LEADS SHOWN

CERAMIC DUAL IN-LINE PACKAGE

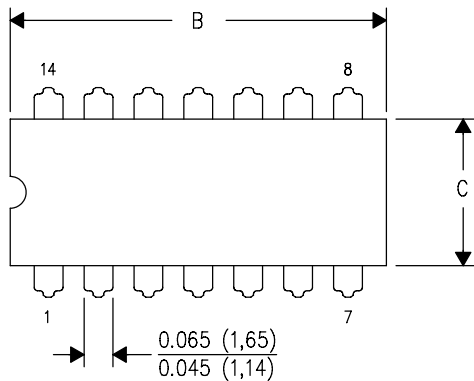

DIM \ PINS **	14	16	18	20
A	0.300 (7,62) BSC	0.300 (7,62) BSC	0.300 (7,62) BSC	0.300 (7,62) BSC
B MAX	0.785 (19,94)	.840 (21,34)	0.960 (24,38)	1.060 (26,92)
B MIN	—	—	—	—
C MAX	0.300 (7,62)	0.300 (7,62)	0.310 (7,87)	0.300 (7,62)
C MIN	0.245 (6,22)	0.245 (6,22)	0.220 (5,59)	0.245 (6,22)



4040083/F 03/03

- NOTES:
- All linear dimensions are in inches (millimeters).
  - This drawing is subject to change without notice.
  - This package is hermetically sealed with a ceramic lid using glass frit.
  - Index point is provided on cap for terminal identification only on press ceramic glass frit seal only.
  - Falls within MIL STD 1835 GDIP1-T14, GDIP1-T16, GDIP1-T18 and GDIP1-T20.

## GENERIC PACKAGE VIEW

**RGY 20**

**VQFN - 1 mm max height**

3.5 x 4.5, 0.5 mm pitch

PLASTIC QUAD FGLATPACK - NO LEAD

This image is a representation of the package family, actual package may vary.  
Refer to the product data sheet for package details.

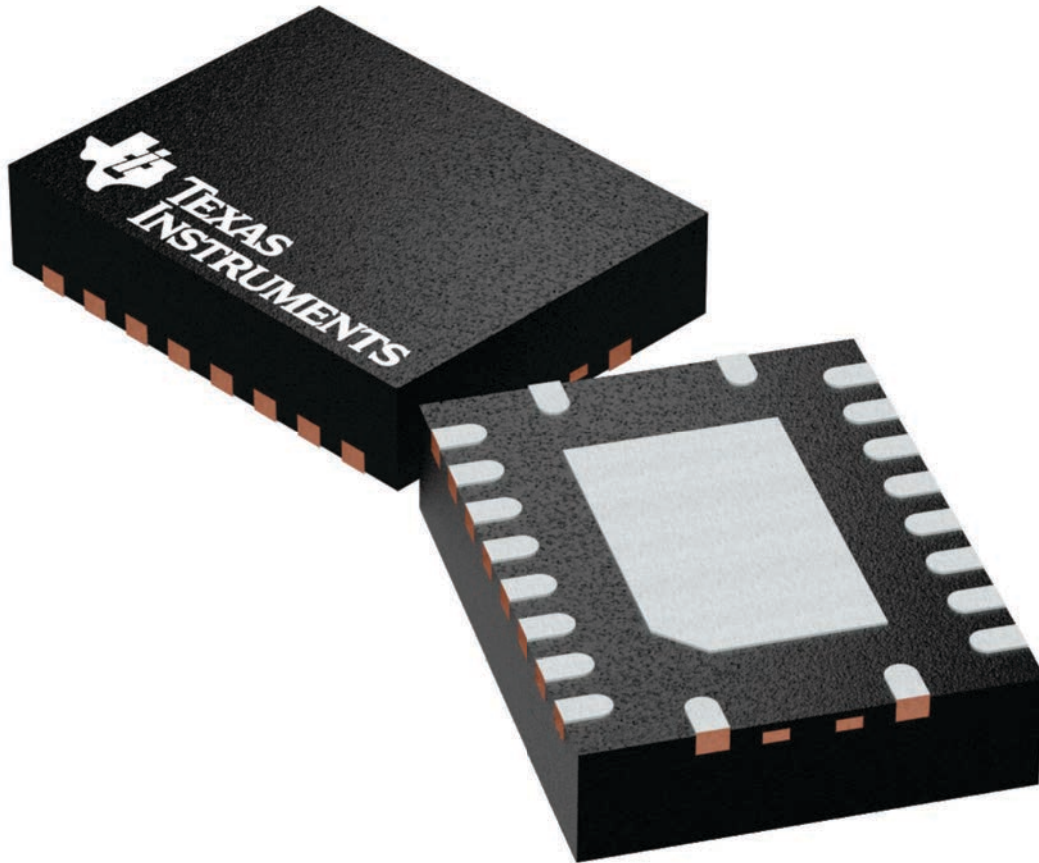

4225264/A

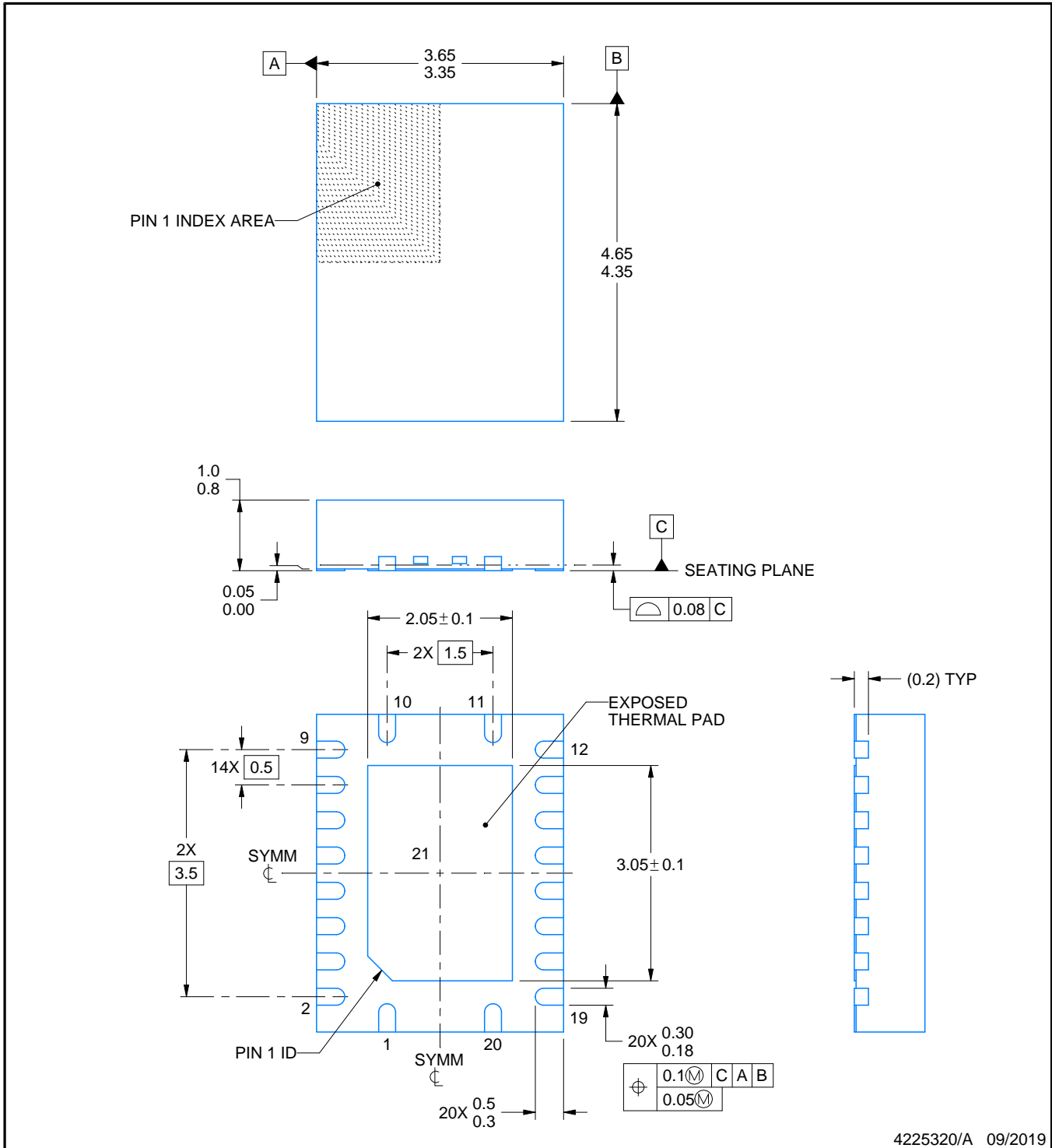
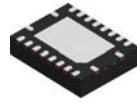

4225320/A 09/2019

NOTES:

1. All linear dimensions are in millimeters. Any dimensions in parenthesis are for reference only. Dimensioning and tolerancing per ASME Y14.5M.
2. This drawing is subject to change without notice.
3. The package thermal pad must be soldered to the printed circuit board for thermal and mechanical performance.

# EXAMPLE BOARD LAYOUT

RGY0020A

VQFN - 1 mm max height

PLASTIC QUAD FLATPACK - NO LEAD

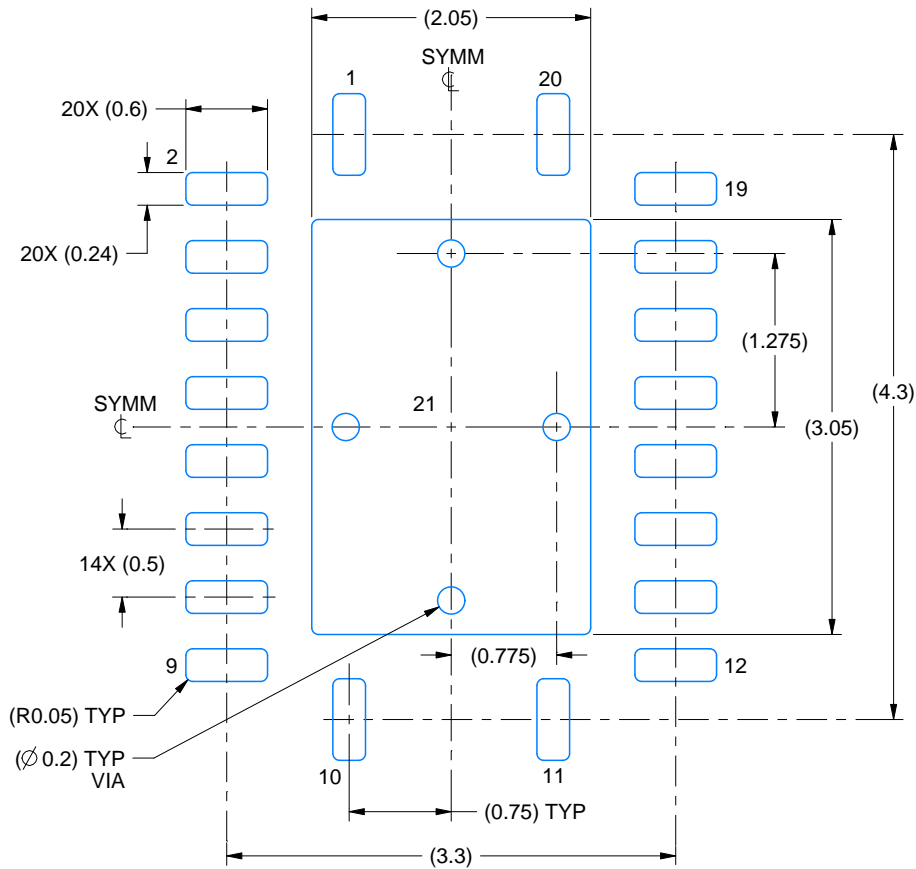

LAND PATTERN EXAMPLE  
EXPOSED METAL SHOWN  
SCALE:18X

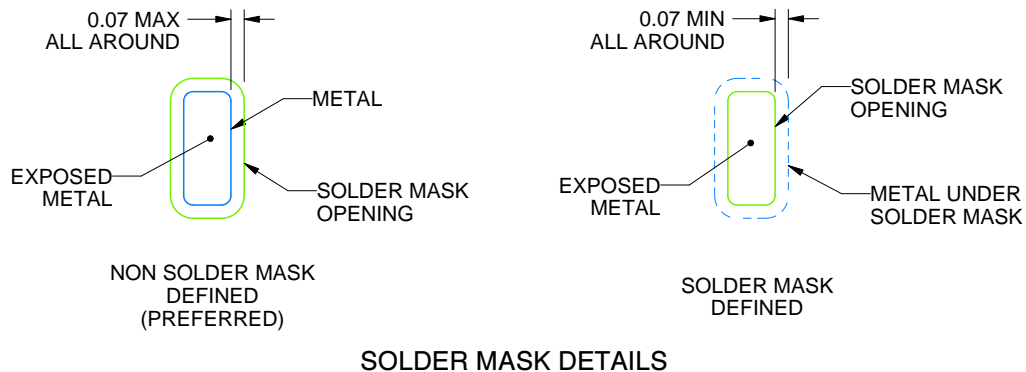

4225320/A 09/2019

NOTES: (continued)

4. This package is designed to be soldered to a thermal pad on the board. For more information, see Texas Instruments literature number SLUA271 ([www.ti.com/lit/slua271](http://www.ti.com/lit/slua271)).
5. Vias are optional depending on application, refer to device data sheet. If any vias are implemented, refer to their locations shown on this view. It is recommended that vias under paste be filled, plugged or tented.

# EXAMPLE STENCIL DESIGN

RGY0020A

VQFN - 1 mm max height

PLASTIC QUAD FLATPACK - NO LEAD

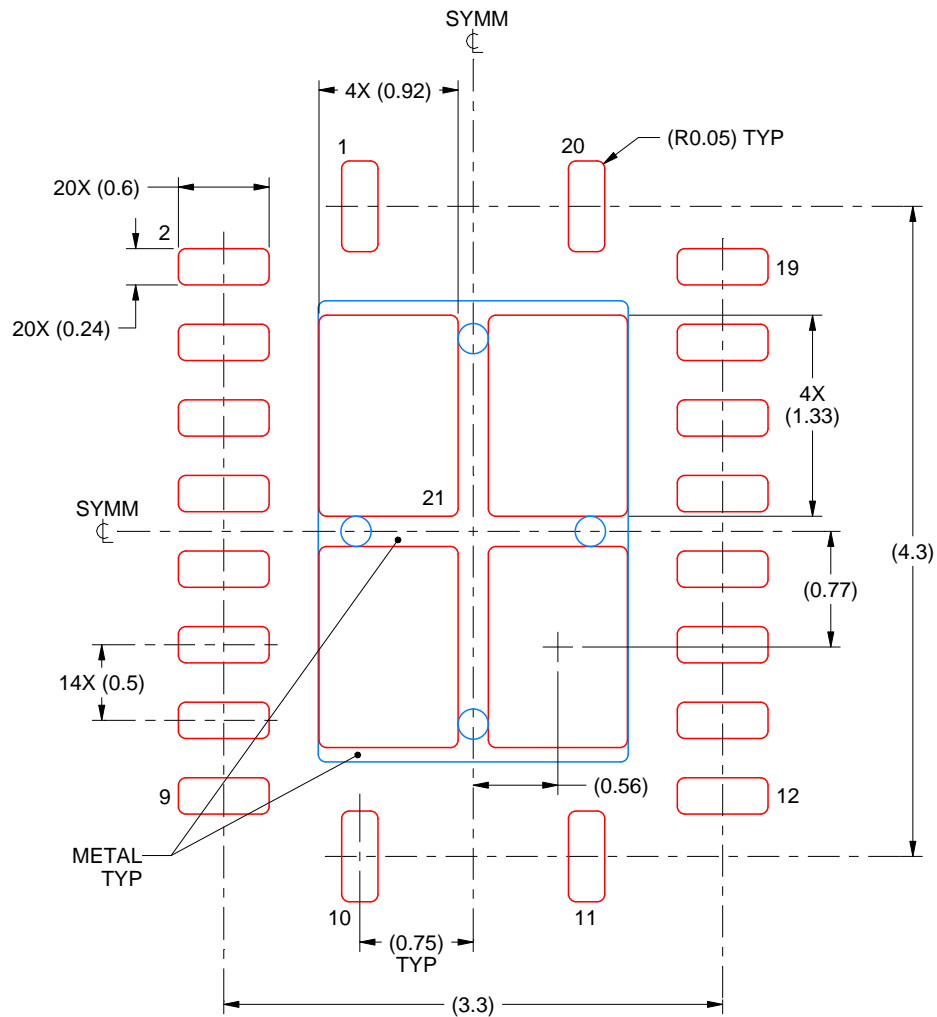

**SOLDER PASTE EXAMPLE**  
 BASED ON 0.125 mm THICK STENCIL

EXPOSED PAD 21  
 78% PRINTED SOLDER COVERAGE BY AREA UNDER PACKAGE  
 SCALE:20X

4225320/A 09/2019

NOTES: (continued)

6. Laser cutting apertures with trapezoidal walls and rounded corners may offer better paste release. IPC-7525 may have alternate design recommendations.

## GENERIC PACKAGE VIEW

**FK 20**

**LCCC - 2.03 mm max height**

8.89 x 8.89, 1.27 mm pitch

LEADLESS CERAMIC CHIP CARRIER

This image is a representation of the package family, actual package may vary.  
Refer to the product data sheet for package details.



4229370VA\



# DW0020A



# PACKAGE OUTLINE

## SOIC - 2.65 mm max height

SOIC

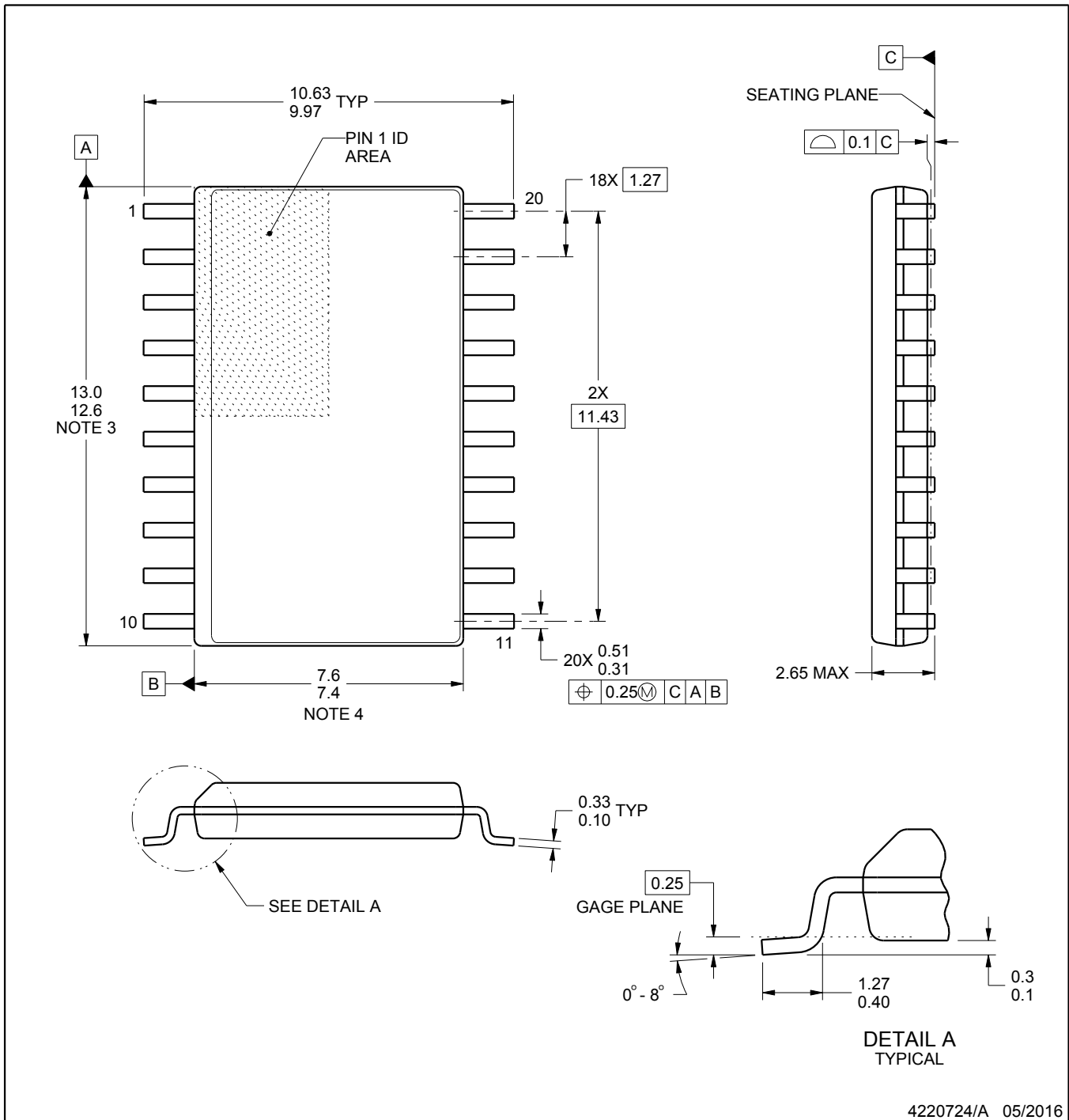

4220724/A 05/2016

**NOTES:**

- All linear dimensions are in millimeters. Dimensions in parenthesis are for reference only. Dimensioning and tolerancing per ASME Y14.5M.
- This drawing is subject to change without notice.
- This dimension does not include mold flash, protrusions, or gate burrs. Mold flash, protrusions, or gate burrs shall not exceed 0.15 mm per side.
- This dimension does not include interlead flash. Interlead flash shall not exceed 0.43 mm per side.
- Reference JEDEC registration MS-013.

# EXAMPLE BOARD LAYOUT

DW0020A

SOIC - 2.65 mm max height

SOIC



LAND PATTERN EXAMPLE  
SCALE:6X



SOLDER MASK DETAILS

4220724/A 05/2016

NOTES: (continued)

- 6. Publication IPC-7351 may have alternate designs.
- 7. Solder mask tolerances between and around signal pads can vary based on board fabrication site.

# EXAMPLE STENCIL DESIGN

DW0020A

SOIC - 2.65 mm max height

SOIC

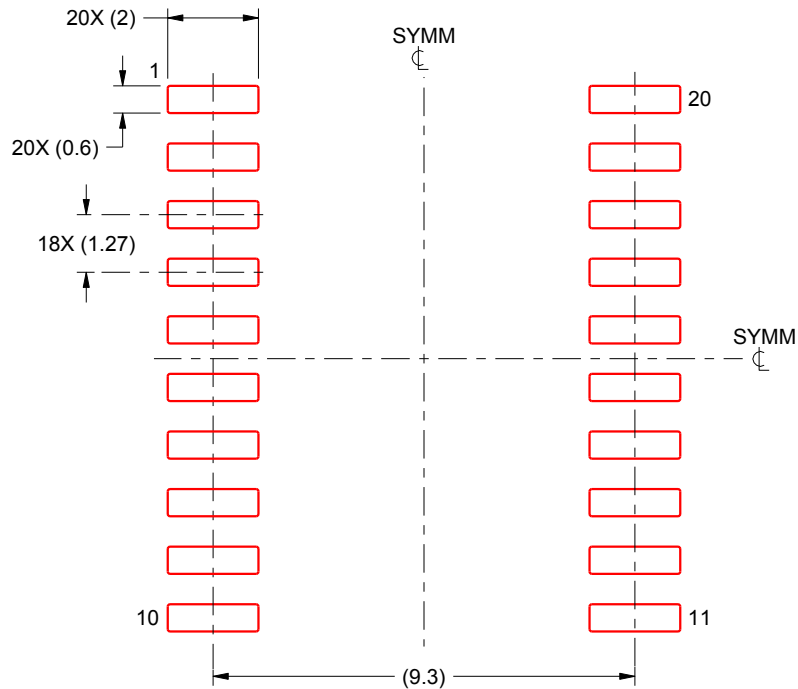

SOLDER PASTE EXAMPLE  
BASED ON 0.125 mm THICK STENCIL  
SCALE:6X

4220724/A 05/2016

NOTES: (continued)

8. Laser cutting apertures with trapezoidal walls and rounded corners may offer better paste release. IPC-7525 may have alternate design recommendations.
9. Board assembly site may have different recommendations for stencil design.

## 重要声明和免责声明

TI“按原样”提供技术和可靠性数据（包括数据表）、设计资源（包括参考设计）、应用或其他设计建议、网络工具、安全信息和其他资源，不保证没有瑕疵且不做任何明示或暗示的担保，包括但不限于对适销性、某特定用途方面的适用性或不侵犯任何第三方知识产权的暗示担保。

这些资源可供使用 TI 产品进行设计的熟练开发人员使用。您将自行承担以下全部责任：(1) 针对您的应用选择合适的 TI 产品，(2) 设计、验证并测试您的应用，(3) 确保您的应用满足相应标准以及任何其他功能安全、信息安全、监管或其他要求。

这些资源如有变更，恕不另行通知。TI 授权您仅可将这些资源用于研发本资源所述的 TI 产品的应用。严禁对这些资源进行其他复制或展示。您无权使用任何其他 TI 知识产权或任何第三方知识产权。您应全额赔偿因在这些资源的使用中对 TI 及其代表造成的任何索赔、损害、成本、损失和债务，TI 对此概不负责。

TI 提供的产品受 [TI 的销售条款](#) 或 [ti.com](#) 上其他适用条款/TI 产品随附的其他适用条款的约束。TI 提供这些资源并不会扩展或以其他方式更改 TI 针对 TI 产品发布的适用的担保或担保免责声明。

TI 反对并拒绝您可能提出的任何其他或不同的条款。

邮寄地址：Texas Instruments, Post Office Box 655303, Dallas, Texas 75265

Copyright © 2023，德州仪器 (TI) 公司