

# TDA4VE TDA4AL TDA4VL Jacinto™ 处理器，器件版本 1.0

## 1 特性

### 处理器内核：

- 两个 C7x 浮点、矢量 DSP，性能高达 1.0GHz、160GFLOPS、512GOPS
- 深度学习矩阵乘法加速器 (MMA)，性能高达 8TOPS (8b) (频率为 1.0GHz)
- 具有图像信号处理器 (ISP) 和多个视觉辅助加速器的视觉处理加速器 (VPAC)
- 深度和运动处理加速器 (DMPAC)
- 双核 64 位 Arm® Cortex®-A72 微处理器子系统，性能高达 2GHz
  - 每个双核 Cortex®-A72 集群具有 1MB L2 共享缓存
  - 每个 Cortex®-A72 内核具有 32KB L1 数据缓存和 48KB L1 指令缓存
- 多达六个 Arm® Cortex®-R5F MCU，性能高达 1.0GHz
  - 16K 指令缓存，16K 数据缓存，64K L2 TCM
  - 隔离 MCU 子系统中有两个 Arm® Cortex®-R5F MCU
  - 通用计算分区中有四个 (TDA4VE) 或两个 (TDA4AL/TDA4VL) Arm® Cortex®-R5F MCU
- GPU IMG BXS-4-64，256kB 缓存，高达 800MHz，50GFLOPS，4GTexels/s (TDA4VE 和 TDA4VL)
- 定制设计的互联结构，支持接近于最高的处理能力

### 存储器子系统：

- 高达 4MB 的片上 L3 RAM (具有 ECC 和一致性)
  - ECC 错误保护
  - 共享一致性缓存
  - 支持内部 DMA 引擎
- 多达两个具有 ECC 的外部存储器接口 (EMIF) 模块
  - 支持 LPDDR4 存储器类型
  - 支持高达 4266MT/s 的速度
  - 两条 (TDA4VE) 或一条 (TDA4AL/TDA4VL) 32 位数据总线，每个 EMIF 具有高达 17Gb/s 的内联 ECC
- 通用存储器控制器 (GPMC)
- MAIN 域中有一个 (TDA4AL/TDA4VL) 或两个 (TDA4VE) 512KB 片上 SRAM，受 ECC 保护

### 功能安全：

- 以**功能安全合规型**为目标 (在部分器件型号上)
- 专为功能安全应用开发
- 可提供使 ISO 26262 功能安全系统设计满足 ASIL-D/SIL-3 要求的文档
- 系统功能符合 ASIL-D/SIL-3 要求
- 对于 MCU 域，硬件完整性符合 ASIL-D/SIL-3 要求
- 对于 MAIN 域，硬件完整性符合 ASIL-B/SIL-2 要求
- 对于 MAIN 域的扩展 MCU (EMCU) 部分，硬件完整性符合 ASIL-D/SIL-3 要求
- 安全相关认证
  - 计划通过 ISO 26262 认证

### 器件安全 (在部分器件型号上)：

- 安全引导，提供安全运行时支持
- 客户可编程的根密钥，级别高达 RSA-4K 或 ECC-512
- 嵌入式硬件安全模块
- 加密硬件加速器 - 带 ECC 的 PKA、AES、SHA、RNG、DES 和 3DES

### 高速串行接口：

- 一个 PCI-Express® (PCIe) 第 3 代控制器
  - 每个控制器多达四个通道
  - 第 1 代 (2.5GT/s)、第 2 代 (5.0GT/s) 和第 3 代 (8.0GT/s) 运行，具有自动协商功能
- 一个 USB 3.0 双重角色器件 (DRD) 子系统
  - 增强型超高速第一代端口
  - 支持 Type-C 开关
  - 可独立配置为 USB 主机、USB 外设或 USB DRD
- 两个 CSI2.0 4L RX 加上两个 CSI2.04L TX

### 汽车接口：

- 20 个模块化控制器局域网 (MCAN) 模块，具有完整 CAN-FD 支持

### 显示子系统：

- 一个 (TDA4AL/TDA4VL) 或两个 (TDA4VE) DSI 4L TX (高达 2.5K)
- 一个 eDP 4L (TDA4VE/TDA4VL)
- 一个 DPI

### 音频接口：

- 5 个多通道音频串行端口 (MCASP) 模块



**TDA4VE-Q1, TDA4AL-Q1, TDA4VL-Q1**

ZHCSRF7A - DECEMBER 2022 - REVISED AUGUST 2023

- TDA4VE : H.264/H.265 编码/解码 ( 高达 480MP/s )
- TDA4AL : 仅限 H.264/H.265 编码/解码 ( 高达 480MP/s )
- TDA4VL : H.264/H.265 编码/解码 ( 高达 240MP/s )

**以太网 :**

- 两个 RMII/RGMII 接口

**闪存接口 :**

- 嵌入式多媒体卡接口 (eMMC™ 5.1)
- 一个安全数字® 3.0/安全数字输入输出 3.0 接口 (SD3.0/SDIO3.0)
- 2 个同步闪存接口, 配置为
  - 一个 OSPI 或 HyperBus™ 或 QSPI, 以及
  - 一个 QSPI

**片上系统 (SoC) 架构 :**

- 16nm FinFET 技术
- 23mm x 23mm、0.8mm 间距、770 引脚 FCBGA (ALZ)

**配套电源管理 IC (PMIC) :**

- 以功能安全合规型为目标, 最高支持 ASIL-D/SIL-3
- 灵活的映射, 可支持不同的用例

## 2 应用

- 高级驾驶员辅助系统 (ADAS)
- 机器视觉
- 工业运输
- 零售自动化
- 监控

## 3 说明

TDA4VE TDA4AL TDA4VL 处理器系列采用不断发展的 Jacinto™ 7 架构, 面向智能视觉摄像头应用, 基于 TI 在视觉处理器市场上十多年所积累的广泛先进市场知识而构建。TDA4AL 以业界卓越的功耗/性能比为传统和深度学习算法提供高性能计算, 并且系统集成度高, 可为高级视觉摄像头应用实现可扩展性和更低的成本。关键内核包括具有标量和矢量内核的下一代 DSP、专用深度学习和传统算法加速器、用于通用计算的最新 Arm 和 GPU 处理器、集成式下一代成像子系统 (ISP)、视频编解码器以及隔离式 MCU 岛。所有这些都由汽车级安全硬件加速器提供保护。

**主要高性能内核概述 :** “C7x” 下一代 DSP 将 TI 先进的 DSP 和 EVE 内核整合到单个性能更高的内核中, 并增加了浮点矢量计算功能, 从而实现了旧代码的向后兼容性, 同时简化了软件编程。在典型的汽车最坏情况结温 125°C 下运行时, 新型 “MMA” 深度学习加速器可在业界超低的功率范围内实现高达 8TOPS 的性能。专用的视觉硬件加速器可提供视觉预处理而不会影响系统性能。

**通用计算内核和集成概述 :** 对 Arm® Cortex®-A72 的独立双核集群配置有助于实现多操作系统应用, 而且对软件管理程序的需求非常低。最多四个 Arm® Cortex®-R5F 子系统能够管理低级的时序关键型处理任务, 使 Arm® Cortex®-A72 内核不受应用的影响。TI 的第 7 代 ISP 以现有出色的 ISP 为基础, 能够灵活地处理更广泛的传感器套件, 支持更高的位深度, 并且具有面向分析应用的特性。集成的诊断和安全功能可支持高达 ASIL-D 级别的运行, 同时集成的安全功能可保护数据免受现代攻击。CSI2.0 端口支持多传感器输入。为了进一步集成, TDA4VE TDA4AL TDA4VL 系列还包含一个 MCU 岛, 从而无需使用外部系统微控制器。

### 封装信息

器件型号	封装 <sup>(1)</sup>	封装尺寸 <sup>(2)</sup>
TDA4VE-Q1	ALZ ( FCBGA , 770 )	23mm × 23mm
TDA4AL-Q1	ALZ ( FCBGA , 770 )	23mm × 23mm
TDA4VL-Q1	ALZ ( FCBGA , 770 )	23mm × 23mm

- (1) 有关更多信息, 请参阅 [机械、封装和可订购信息](#) 部分。
- (2) 封装尺寸 ( 长 × 宽 ) 为标称值, 并包括引脚 ( 如适用 )。

### 3.1 功能方框图

图 3-1 是器件的功能方框图。

**备注**

要了解 TI 软件开发套件 (SDK) 目前支持的器件功能，请参阅 [TDA4VE 软件构建表 \(PROCESSOR-SDK-J721S2\)](#)。



图 3-1. 功能方框图

## Table of Contents

<b>1 特性</b> .....	1	7.8 Thermal Resistance Characteristics.....	115
<b>2 应用</b> .....	2	7.9 Temperature Sensor Characteristics.....	116
<b>3 说明</b> .....	2	7.10 Timing and Switching Characteristics.....	117
3.1 功能方框图.....	3	<b>8 Applications, Implementation, and Layout</b> .....	234
<b>4 Revision History</b> .....	5	8.1 Device Connection and Layout Fundamentals.....	234
<b>5 Device Comparison</b> .....	6	8.2 Peripheral- and Interface-Specific Design Information.....	234
<b>6 Terminal Configuration and Functions</b> .....	8	<b>9 Device and Documentation Support</b> .....	241
6.1 Pin Diagrams.....	8	9.1 Device Nomenclature.....	241
6.2 Pin Attributes.....	8	9.2 Tools and Software.....	244
6.3 Signal Descriptions.....	60	9.3 Documentation Support.....	244
6.4 Connection for Unused Pins.....	97	9.4 Trademarks.....	244
<b>7 Specifications</b> .....	100	9.5 支持资源.....	244
7.1 Absolute Maximum Ratings.....	100	9.6 静电放电警告.....	245
7.2 ESD Ratings.....	103	9.7 术语表.....	245
7.3 Recommended Operating Conditions.....	103	<b>10 Mechanical, Packaging, and Orderable Information</b> .....	246
7.4 Power-On-Hour (POH) Limits.....	105	10.1 Packaging Information.....	246
7.5 Operating Performance Points.....	106		
7.6 Electrical Characteristics.....	107		
7.7 VPP Specifications for One-Time Programmable (OTP) eFuses.....	113		

## 4 Revision History

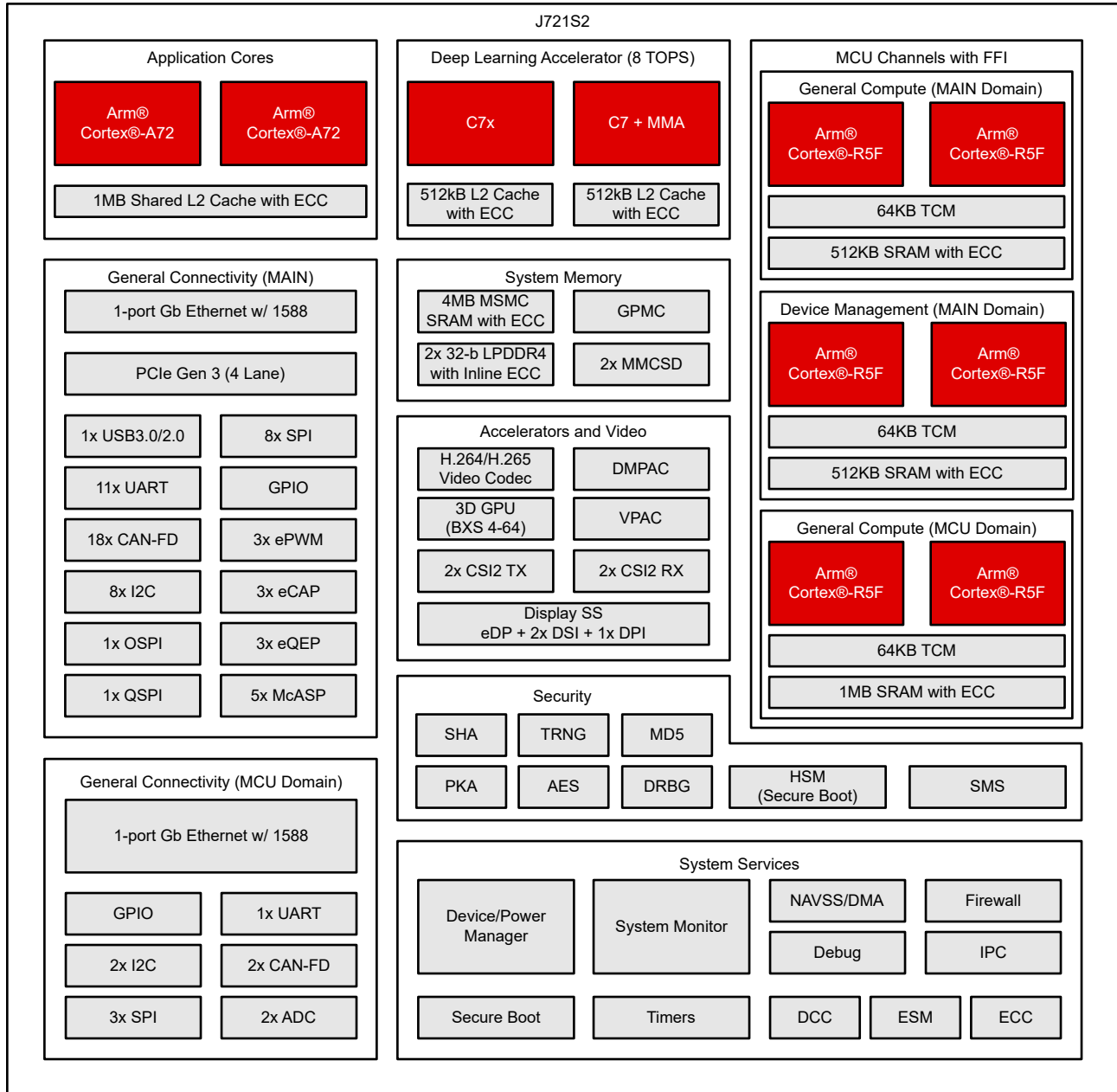
### Changes from December 21, 2022 to August 18, 2023 (from Revision \* (DECEMBER 2022) to Revision A (AUGUST 2023))

	Page
• 通篇：删除了所有 OLDI/LVDS 内容；不适用于此器件套件.....	1
• 通篇：将 3D 图形处理单元 (GPU) 的“BSX”、“BSX-64-4”和“BXS-64-4”更新/更改为“IMG BXS-4-64”.....	1
• (封装信息)：更新了表以与新的内容标准一致.....	2
• (功能方框图)：更新了图像以显示超集器件并删除了脚注.....	3
• (功能方框图)：添加了软件构建表注释.....	3
• (Device Comparison): Merged table cells to show commonality/differences and to improve readability.....	6
• (Device Comparison): Added software build sheet Note.....	6
• (Pin Attributes): Deleted "Buffer Types with Pull Type and Hysteresis Associations" table.....	9
• (Pin Attributes): Added HYS, BUFFER TYPE, and PULL UP/DOWN TYPE columns to "Pin Attributes (ALZ Package)" table.....	9
• (Pin Attributes): Updated/Changed the address range for PADCONFIG_0 through PADCONFIG_79 registers from "0x4301C000 to 0x4301C11C" to "0x0011C000 to 0x0011C11C".....	9
• (DDRSS0 Signal Descriptions): Added "DDRSS incremental order" footnote.....	61
• (DDRSS1 Signal Descriptions): Added "DDRSS incremental order" footnote.....	62
• (MMC0 Signal Descriptions): Deleted the external pull-up connection footnote.....	89
• (Pin Connectivity Requirements) Updated ADC AIN recommendation to allow the tie-off of signals directly to ground.....	97
• (Pin Connectivity Requirements): Added requirement for DDR interfaces to be used in incrementing order..	97
• (Recommended Operating Conditions): Added clarification to the "... supply inputs" footnote, specifically for VDD_CORE, VDD_MCU, and VDD_CPU domains plus, added cross-references to the MIN/MAX values..	103
• (LVCMOS Electrical Characteristics): Added missing R <sub>PU</sub> , pull up resistor row for 3.3-V MODE.....	111
• (USB VBUS Design Guidelines): Updated/Changed USB VBUS Detect Voltage Divider / Clamp Circuit figure.....	237

## 5 Device Comparison

表 5-1 shows the features of the SoC.

### 备注

To understand what device features are currently supported by TI Software Development Kits (SDKs), see the [TDA4VE Software Build Sheet \(PROCESSOR-SDK-J721S2\)](#).

**表 5-1. Device Comparison**

FEATURES <sup>(7)</sup>	REFERENCE NAME	TDA4VE88	TDA4AL88	TDA4VL21
<b>PROCESSORS AND ACCELERATORS</b>				
Speed Grades		T, N	T, N	H
Arm Cortex-A72 Microprocessor Subsystem	Arm A72	Dual Core		
Arm Cortex-R5F	Arm R5F	Hexa Core	Quad Core	
	Lockstep	Optional <sup>(1)</sup>		
Security Management Subsystem	SMS	Yes		
Security Accelerators	SA	Yes		
C7x Floating Point, Vector DSP	C7x DSP	Dual Core		
Deep Learning Accelerator	MMA	Yes		
Graphics Accelerator IMG BXS-4-64	GPU	Yes	No	Yes
Depth and Motion Processing Accelerators	DMPAC	Yes		
Vision Processing Accelerators	VPAC	Yes		
Video Encoder/Decoder	VENC/VDEC	Enc/Dec	Enc only	Enc/Dec
<b>SAFETY AND SECURITY</b>				
Safety Targeted	Safety	Optional <sup>(1)</sup>		
Device Security	Security	Optional <sup>(2)</sup>		
AEC-Q100 Qualified	Q1	Optional <sup>(3)</sup>		
<b>PROGRAM AND DATA STORAGE</b>				
On-Chip Shared Memory (RAM) in MAIN Domain	OCSRAM	2x512KB SRAM	1x512KB SRAM	
On-Chip Shared Memory (RAM) in MCU Domain	MCU_MSRAM	1MB SRAM		
Multicore Shared Memory Controller	MSMC	4MB (On-Chip SRAM with ECC)		
LPDDR4 DDR Subsystem	DDRSS0 <sup>(4)</sup>	Up to 8GB (32-bit data) with inline ECC		
	DDRSS1 <sup>(4)</sup>	Up to 8GB (32-bit data) with inline ECC	No <sup>(9)</sup>	
	SECEDED	7-Bit		
General-Purpose Memory Controller	GPMC	Up to 1GB with ECC		
<b>PERIPHERALS</b>				
Display Subsystem	DSS	Yes		
	DSI 4L TX	2	1 <sup>(11)</sup>	
	eDP 4L	1	0	1
	DPI	1		
Modular Controller Area Network Interface with Full CAN-FD Support	MCAN	20		
General-Purpose I/O	GPIO	155		
Inter-Integrated Circuit Interface	I2C	10		
Improved Inter-Integrated Circuit Interface	I3C	1		
Analog-to-Digital Converter	ADC	2		

**表 5-1. Device Comparison (continued)**

FEATURES <sup>(7)</sup>	REFERENCE NAME	TDA4VE88	TDA4AL88	TDA4VL21
Capture Subsystem with Camera Serial Interface (CSI2)	CSI2.0 4L RX		2	
	CSI2.0 4L TX		2	
Multichannel Serial Peripheral Interface	MCSP1		11	
Multichannel Audio Serial Port	MCASP0		16 Serializers	
	MCASP1		5 Serializers	
	MCASP2		5 Serializers	
	MCASP3		3 Serializers	
	MCASP4		5 Serializers	
MultiMedia Card/ Secure Digital Interface	MMCSD0		eMMC (8-bits)	
	MMCSD1		SD/SDIO (4-bits)	
Universal Flash Storage	UFS 2L		No	
Flash Subsystem (FSS)	OSPI0		8-bits <sup>(6)</sup>	
	OSPI1 <sup>(8)</sup>		4-bits	
	HyperBus		Yes <sup>(6)</sup>	
4x PCI Express Port with Integrated PHY	PCIE0		Up to Four Lanes <sup>(5)</sup>	
Hyperlink	HYP		No <sup>(10)</sup>	
Gigabit Ethernet Interface	MCU		1x RGMII or RMII	
	Main		1x RGMII or RMII	
General-Purpose Timers	TIMER		30	
Enhanced High Resolution Pulse-Width Modulator Module	eHRPWM		6	
Enhanced Capture Module	eCAP		3	
Enhanced Quadrature Encoder Pulse Module	eQEP		3	
Universal Asynchronous Receiver and Transmitter	UART		12	
Universal Serial Bus (USB3.1) SuperSpeed Dual-Role-Device (DRD) Ports with SS PHY	USB0		Yes <sup>(5)</sup>	

- (1) Safety features including R5F Lockstep and SIL/ASIL ratings are only applicable to select part number variants as indicated by the Device Type (Y) identifier in the Table 10-1, Nomenclature Description table.
- (2) Device security features including Secure Boot and Customer Programmable Keys are applicable to select part number variants as indicated by the Device Type (Y) identifier in the Table 10-1, Nomenclature Description table
- (3) AEC-Q100 qualification is applicable to select part number variants as indicated by the Automotive Designator (Q1) identifier in the Table 10-1, Nomenclature Description table
- (4) DDRSS0 and DDRSS1 must always be used in incremental order. For instance, when using a single LPDDR component, it must be connected to the DDR0\_\* interface
- (5) USB3.0 and PCIE share a total of four SerDes lanes.
- (6) Two simultaneous flash interfaces configured as OSPI0 and OSPI1, or HyperBus and OSPI1.
- (7) J721S2 is the base part number for the superset device. Software should constrain the features used to match the intended production device.
- (8) OSPI1 module only pins out 4 pins and is referred to as QSPI in some contexts.
- (9) Part number variants with DDRSS1 as "No" should not use the DDR1\_\* pins. The DDR1\_\* pins should be connected as recommended in the section titled "Connections for Unused Pins"
- (10) Hyperlink is not supported on this SoC. System designs should not use the signals HYP\_\*, HYP0\_\*, HYP1\_\*.
- (11) Part number variants with DSI 4L TX as "1" can only use the DSI0 interface for DSI functionality. DSI1\* balls can still be used for CSI1 functionality.

## 6 Terminal Configuration and Functions

### 6.1 Pin Diagrams

See Packaging Information.

### 6.2 Pin Attributes

1. **BALL NUMBER:** Ball numbers on the bottom side associated with each signal on the bottom.
2. **BALL NAME:** Mechanical name from package device (name is taken from muxmode 0).
3. **SIGNAL NAME:** Names of signals multiplexed on each ball (also notice that the name of the ball is the signal name in muxmode 0).
4. **MUXMODE:** Multiplexing mode number.
5. **TYPE:** Signal type and direction:
  - I = Input
  - O = Output
  - OD = Open drain terminal - Output
  - IO = Input or Output
  - IOD = Open drain terminal - Input or Output
  - IOZ = Input, Output or Three-state terminal
  - OZ = Output or Three-state terminal
  - A = Analog
  - PWR = Power
  - GND = Ground
  - CAP = LDO Capacitor.
6. **IO VOLTAGE VALUE:** This column describes the IO voltage value (the corresponding power supply).  
An empty box means Not Applicable.
7. **BALL STATE DURING RESET:** This column describes the state of the transmit buffer, receive buffer, and internal pull during reset.
8. **BALL STATE AFTER RESET:** This column describes the state of the transmit buffer, receive buffer, and internal pull after reset.
9. **MUX MODE AFTER RESET:** The active multiplexing mode after reset.
10. **PULL TYPE:** Indicates the presence of an internal pullup or pulldown resistor. Pullup and pulldown resistors can be enabled or disabled via software.
11. **POWER:** The voltage supply that powers the terminal IO buffers.  
An empty box means Not Applicable.
12. **HYS:** Indicates if the input buffer has hysteresis:
  - Yes: With hysteresis
  - No: Without hysteresis

An empty box means No.
13. **VOLTAGE BUFFER TYPE:** This column describes the associated output buffer type.  
An empty box means Not Applicable.
14. **IO RET:** Yes means WKUP and IO retention supported.
15. **PADCFG NAME:** Name of the pad configuration register.
16. **PADCFG ADDRESS:** Address of the pad configuration register.

表 6-1. Pin Attributes (ALZ Package)

Ball Num [1]	Ball Name [2] PADCFG Register [15] PADCFG Address [16]	Signal Name [3]	Mux Mode [4]	Signal Type [5]	I/O Voltage [6]	Ball State DURING Reset (RX/TX/PULL) [7]	Ball State AFTER Reset (RX/TX/PULL) [8]	Mux Mode AFTER Reset [9]	Pull Type [10]	Power [11]	Hys [12]	Voltage Buffer Type [13]	IO RET [14]
T21	CAP_VDDS0	CAP_VDDS0		CAP									
J20	CAP_VDDS0_MCU	CAP_VDDS0_MCU		CAP									
G16	CAP_VDDS1_MCU	CAP_VDDS1_MCU		CAP									
P21	CAP_VDDS2	CAP_VDDS2		CAP									
H17	CAP_VDDS2_MCU	CAP_VDDS2_MCU		CAP									
M22	CAP_VDDS5	CAP_VDDS5		CAP									
AH19	CSI0_RXCLKN	CSI0_RXCLKN		I	1.8 V					VDDA_0P8_C SIRX0_1 / VDDA_1P8_C SIRX0_1		D-PHY	
AH20	CSI0_RXCLKP	CSI0_RXCLKP		I	1.8 V					VDDA_0P8_C SIRX0_1 / VDDA_1P8_C SIRX0_1		D-PHY	
AC18	CSI0_RXRCALIB	CSI0_RXRCALIB		A	1.8 V					VDDA_0P8_C SIRX0_1 / VDDA_1P8_C SIRX0_1		D-PHY	
AH22	CSI1_RXCLKN	CSI1_RXCLKN		I	1.8 V					VDDA_0P8_C SIRX0_1 / VDDA_1P8_C SIRX0_1		D-PHY	
AH23	CSI1_RXCLKP	CSI1_RXCLKP		I	1.8 V					VDDA_0P8_C SIRX0_1 / VDDA_1P8_C SIRX0_1		D-PHY	
AC21	CSI1_RXRCALIB	CSI1_RXRCALIB		A	1.8 V					VDDA_0P8_C SIRX0_1 / VDDA_1P8_C SIRX0_1		D-PHY	
AG18	CSI0_RXN0	CSI0_RXN0		I	1.8 V					VDDA_0P8_C SIRX0_1 / VDDA_1P8_C SIRX0_1		D-PHY	
AF19	CSI0_RXN1	CSI0_RXN1		I	1.8 V					VDDA_0P8_C SIRX0_1 / VDDA_1P8_C SIRX0_1		D-PHY	
AE18	CSI0_RXN2	CSI0_RXN2		I	1.8 V					VDDA_0P8_C SIRX0_1 / VDDA_1P8_C SIRX0_1		D-PHY	
AD19	CSI0_RXN3	CSI0_RXN3		I	1.8 V					VDDA_0P8_C SIRX0_1 / VDDA_1P8_C SIRX0_1		D-PHY	

表 6-1. Pin Attributes (ALZ Package) (continued)

Ball Num [1]	Ball Name [2] PADCFG Register [15] PADCFG Address [16]	Signal Name [3]	Mux Mode [4]	Signal Type [5]	I/O Voltage [6]	Ball State DURING Reset (RX/TX/PULL) [7]	Ball State AFTER Reset (RX/TX/PULL) [8]	Mux Mode AFTER Reset [9]	Pull Type [10]	Power [11]	Hys [12]	Voltage Buffer Type [13]	IO RET [14]
AG19	CSI0_RXP0	CSI0_RXP0		I	1.8 V					VDDA_0P8_C SIRX0_1 / VDDA_1P8_C SIRX0_1		D-PHY	
AF20	CSI0_RXP1	CSI0_RXP1		I	1.8 V					VDDA_0P8_C SIRX0_1 / VDDA_1P8_C SIRX0_1		D-PHY	
AE19	CSI0_RXP2	CSI0_RXP2		I	1.8 V					VDDA_0P8_C SIRX0_1 / VDDA_1P8_C SIRX0_1		D-PHY	
AD20	CSI0_RXP3	CSI0_RXP3		I	1.8 V					VDDA_0P8_C SIRX0_1 / VDDA_1P8_C SIRX0_1		D-PHY	
AG21	CSI1_RXN0	CSI1_RXN0		I	1.8 V					VDDA_0P8_C SIRX0_1 / VDDA_1P8_C SIRX0_1		D-PHY	
AF22	CSI1_RXN1	CSI1_RXN1		I	1.8 V					VDDA_0P8_C SIRX0_1 / VDDA_1P8_C SIRX0_1		D-PHY	
AE21	CSI1_RXN2	CSI1_RXN2		I	1.8 V					VDDA_0P8_C SIRX0_1 / VDDA_1P8_C SIRX0_1		D-PHY	
AD22	CSI1_RXN3	CSI1_RXN3		I	1.8 V					VDDA_0P8_C SIRX0_1 / VDDA_1P8_C SIRX0_1		D-PHY	
AG22	CSI1_RXP0	CSI1_RXP0		I	1.8 V					VDDA_0P8_C SIRX0_1 / VDDA_1P8_C SIRX0_1		D-PHY	
AF23	CSI1_RXP1	CSI1_RXP1		I	1.8 V					VDDA_0P8_C SIRX0_1 / VDDA_1P8_C SIRX0_1		D-PHY	
AE22	CSI1_RXP2	CSI1_RXP2		I	1.8 V					VDDA_0P8_C SIRX0_1 / VDDA_1P8_C SIRX0_1		D-PHY	
AD23	CSI1_RXP3	CSI1_RXP3		I	1.8 V					VDDA_0P8_C SIRX0_1 / VDDA_1P8_C SIRX0_1		D-PHY	
R1	DDR0_CKN	DDR0_CKN		IO	1.1 V					VDDS_DDR / VDDS_DDR_ CO		DDR	

表 6-1. Pin Attributes (ALZ Package) (continued)

Ball Num [1]	Ball Name [2] PADCFG Register [15] PADCFG Address [16]	Signal Name [3]	Mux Mode [4]	Signal Type [5]	I/O Voltage [6]	Ball State DURING Reset (RX/TX/PULL) [7]	Ball State AFTER Reset (RX/TX/PULL) [8]	Mux Mode AFTER Reset [9]	Pull Type [10]	Power [11]	Hys [12]	Voltage Buffer Type [13]	IO RET [14]
P1	DDR0_CKP	DDR0_CKP		IO	1.1 V					VDDS_DDR / VDDS_DDR_C0		DDR	
R5	DDR0_RESETh	DDR0_RESETh		IO	1.1 V					VDDS_DDR / VDDS_DDR_C0		DDR	
T8	DDR0_RET	DDR0_RET		I	1.1 V					VDDS_DDR / VDDS_DDR_C0		DDR	
A9	DDR1_CKN	DDR1_CKN		IO	1.1 V					VDDS_DDR / VDDS_DDR_C1		DDR	
A10	DDR1_CKP	DDR1_CKP		IO	1.1 V					VDDS_DDR / VDDS_DDR_C1		DDR	
F12	DDR1_RESETh	DDR1_RESETh		IO	1.1 V					VDDS_DDR / VDDS_DDR_C1		DDR	
J10	DDR1_RET	DDR1_RET		I	1.1 V					VDDS_DDR / VDDS_DDR_C1		DDR	
P3	DDR0_CA0	DDR0_CA0		IO	1.1 V					VDDS_DDR / VDDS_DDR_C0		DDR	
P5	DDR0_CA1	DDR0_CA1		IO	1.1 V					VDDS_DDR / VDDS_DDR_C0		DDR	
N5	DDR0_CA2	DDR0_CA2		IO	1.1 V					VDDS_DDR / VDDS_DDR_C0		DDR	
P2	DDR0_CA3	DDR0_CA3		IO	1.1 V					VDDS_DDR / VDDS_DDR_C0		DDR	
P4	DDR0_CA4	DDR0_CA4		IO	1.1 V					VDDS_DDR / VDDS_DDR_C0		DDR	
R3	DDR0_CA5	DDR0_CA5		IO	1.1 V					VDDS_DDR / VDDS_DDR_C0		DDR	
R8	DDR0_CAL0	DDR0_CAL0		A	1.1 V					VDDS_DDR / VDDS_DDR_C0		DDR	
R2	DDR0_CKE0	DDR0_CKE0		IO	1.1 V					VDDS_DDR / VDDS_DDR_C0		DDR	
R4	DDR0_CKE1	DDR0_CKE1		IO	1.1 V					VDDS_DDR / VDDS_DDR_C0		DDR	

表 6-1. Pin Attributes (ALZ Package) (continued)

Ball Num [1]	Ball Name [2] PADCFG Register [15] PADCFG Address [16]	Signal Name [3]	Mux Mode [4]	Signal Type [5]	I/O Voltage [6]	Ball State DURING Reset (RX/TX/PULL) [7]	Ball State AFTER Reset (RX/TX/PULL) [8]	Mux Mode AFTER Reset [9]	Pull Type [10]	Power [11]	Hys [12]	Voltage Buffer Type [13]	IO RET [14]
V5	DDR0_CSn0_0	DDR0_CSn0_0		IO	1.1 V					VDDS_DDR / VDDS_DDR_C0		DDR	
W5	DDR0_CSn0_1	DDR0_CSn0_1		IO	1.1 V					VDDS_DDR / VDDS_DDR_C0		DDR	
T5	DDR0_CSn1_0	DDR0_CSn1_0		IO	1.1 V					VDDS_DDR / VDDS_DDR_C0		DDR	
U6	DDR0_CSn1_1	DDR0_CSn1_1		IO	1.1 V					VDDS_DDR / VDDS_DDR_C0		DDR	
H5	DDR0_DM0	DDR0_DM0		IO	1.1 V					VDDS_DDR / VDDS_DDR_C0		DDR	
M3	DDR0_DM1	DDR0_DM1		IO	1.1 V					VDDS_DDR / VDDS_DDR_C0		DDR	
U4	DDR0_DM2	DDR0_DM2		IO	1.1 V					VDDS_DDR / VDDS_DDR_C0		DDR	
AD1	DDR0_DM3	DDR0_DM3		IO	1.1 V					VDDS_DDR / VDDS_DDR_C0		DDR	
F3	DDR0_DQ0	DDR0_DQ0		IO	1.1 V					VDDS_DDR / VDDS_DDR_C0		DDR	
G4	DDR0_DQ1	DDR0_DQ1		IO	1.1 V					VDDS_DDR / VDDS_DDR_C0		DDR	
F5	DDR0_DQ2	DDR0_DQ2		IO	1.1 V					VDDS_DDR / VDDS_DDR_C0		DDR	
F1	DDR0_DQ3	DDR0_DQ3		IO	1.1 V					VDDS_DDR / VDDS_DDR_C0		DDR	
J4	DDR0_DQ4	DDR0_DQ4		IO	1.1 V					VDDS_DDR / VDDS_DDR_C0		DDR	
H3	DDR0_DQ5	DDR0_DQ5		IO	1.1 V					VDDS_DDR / VDDS_DDR_C0		DDR	
J2	DDR0_DQ6	DDR0_DQ6		IO	1.1 V					VDDS_DDR / VDDS_DDR_C0		DDR	
G2	DDR0_DQ7	DDR0_DQ7		IO	1.1 V					VDDS_DDR / VDDS_DDR_C0		DDR	

表 6-1. Pin Attributes (ALZ Package) (continued)

Ball Num [1]	Ball Name [2] PADCFG Register [15] PADCFG Address [16]	Signal Name [3]	Mux Mode [4]	Signal Type [5]	I/O Voltage [6]	Ball State DURING Reset (RX/TX/PULL) [7]	Ball State AFTER Reset (RX/TX/PULL) [8]	Mux Mode AFTER Reset [9]	Pull Type [10]	Power [11]	Hys [12]	Voltage Buffer Type [13]	IO RET [14]
K5	DDR0_DQ8	DDR0_DQ8		IO	1.1 V					VDDS_DDR / VDDS_DDR_C0		DDR	
M5	DDR0_DQ9	DDR0_DQ9		IO	1.1 V					VDDS_DDR / VDDS_DDR_C0		DDR	
K3	DDR0_DQ10	DDR0_DQ10		IO	1.1 V					VDDS_DDR / VDDS_DDR_C0		DDR	
K1	DDR0_DQ11	DDR0_DQ11		IO	1.1 V					VDDS_DDR / VDDS_DDR_C0		DDR	
N4	DDR0_DQ12	DDR0_DQ12		IO	1.1 V					VDDS_DDR / VDDS_DDR_C0		DDR	
N2	DDR0_DQ13	DDR0_DQ13		IO	1.1 V					VDDS_DDR / VDDS_DDR_C0		DDR	
L4	DDR0_DQ14	DDR0_DQ14		IO	1.1 V					VDDS_DDR / VDDS_DDR_C0		DDR	
L2	DDR0_DQ15	DDR0_DQ15		IO	1.1 V					VDDS_DDR / VDDS_DDR_C0		DDR	
T1	DDR0_DQ16	DDR0_DQ16		IO	1.1 V					VDDS_DDR / VDDS_DDR_C0		DDR	
T3	DDR0_DQ17	DDR0_DQ17		IO	1.1 V					VDDS_DDR / VDDS_DDR_C0		DDR	
V3	DDR0_DQ18	DDR0_DQ18		IO	1.1 V					VDDS_DDR / VDDS_DDR_C0		DDR	
U2	DDR0_DQ19	DDR0_DQ19		IO	1.1 V					VDDS_DDR / VDDS_DDR_C0		DDR	
W2	DDR0_DQ20	DDR0_DQ20		IO	1.1 V					VDDS_DDR / VDDS_DDR_C0		DDR	
W4	DDR0_DQ21	DDR0_DQ21		IO	1.1 V					VDDS_DDR / VDDS_DDR_C0		DDR	
Y1	DDR0_DQ22	DDR0_DQ22		IO	1.1 V					VDDS_DDR / VDDS_DDR_C0		DDR	
Y3	DDR0_DQ23	DDR0_DQ23		IO	1.1 V					VDDS_DDR / VDDS_DDR_C0		DDR	

表 6-1. Pin Attributes (ALZ Package) (continued)

Ball Num [1]	Ball Name [2] PADCFG Register [15] PADCFG Address [16]	Signal Name [3]	Mux Mode [4]	Signal Type [5]	I/O Voltage [6]	Ball State DURING Reset (RX/TX/PULL) [7]	Ball State AFTER Reset (RX/TX/PULL) [8]	Mux Mode AFTER Reset [9]	Pull Type [10]	Power [11]	Hys [12]	Voltage Buffer Type [13]	IO RET [14]
AB3	DDR0_DQ24	DDR0_DQ24		IO	1.1 V					VDDS_DDR / VDDS_DDR_C0		DDR	
AA2	DDR0_DQ25	DDR0_DQ25		IO	1.1 V					VDDS_DDR / VDDS_DDR_C0		DDR	
AA4	DDR0_DQ26	DDR0_DQ26		IO	1.1 V					VDDS_DDR / VDDS_DDR_C0		DDR	
Y5	DDR0_DQ27	DDR0_DQ27		IO	1.1 V					VDDS_DDR / VDDS_DDR_C0		DDR	
AC2	DDR0_DQ28	DDR0_DQ28		IO	1.1 V					VDDS_DDR / VDDS_DDR_C0		DDR	
AB5	DDR0_DQ29	DDR0_DQ29		IO	1.1 V					VDDS_DDR / VDDS_DDR_C0		DDR	
AD2	DDR0_DQ30	DDR0_DQ30		IO	1.1 V					VDDS_DDR / VDDS_DDR_C0		DDR	
AC4	DDR0_DQ31	DDR0_DQ31		IO	1.1 V					VDDS_DDR / VDDS_DDR_C0		DDR	
H1	DDR0_QS0N	DDR0_QS0N		IO	1.1 V					VDDS_DDR / VDDS_DDR_C0		DDR	
G1	DDR0_QS0P	DDR0_QS0P		IO	1.1 V					VDDS_DDR / VDDS_DDR_C0		DDR	
M1	DDR0_QS1N	DDR0_QS1N		IO	1.1 V					VDDS_DDR / VDDS_DDR_C0		DDR	
L1	DDR0_QS1P	DDR0_QS1P		IO	1.1 V					VDDS_DDR / VDDS_DDR_C0		DDR	
U1	DDR0_QS2N	DDR0_QS2N		IO	1.1 V					VDDS_DDR / VDDS_DDR_C0		DDR	
V1	DDR0_QS2P	DDR0_QS2P		IO	1.1 V					VDDS_DDR / VDDS_DDR_C0		DDR	
AC1	DDR0_QS3N	DDR0_QS3N		IO	1.1 V					VDDS_DDR / VDDS_DDR_C0		DDR	
AB1	DDR0_QS3P	DDR0_QS3P		IO	1.1 V					VDDS_DDR / VDDS_DDR_C0		DDR	

表 6-1. Pin Attributes (ALZ Package) (continued)

Ball Num [1]	Ball Name [2] PADCFG Register [15] PADCFG Address [16]	Signal Name [3]	Mux Mode [4]	Signal Type [5]	I/O Voltage [6]	Ball State DURING Reset (RX/TX/PULL) [7]	Ball State AFTER Reset (RX/TX/PULL) [8]	Mux Mode AFTER Reset [9]	Pull Type [10]	Power [11]	Hys [12]	Voltage Buffer Type [13]	IO RET [14]
C10	DDR1_CA0	DDR1_CA0		IO	1.1 V					VDDS_DDR / VDDS_DDR_C1		DDR	
E10	DDR1_CA1	DDR1_CA1		IO	1.1 V					VDDS_DDR / VDDS_DDR_C1		DDR	
E9	DDR1_CA2	DDR1_CA2		IO	1.1 V					VDDS_DDR / VDDS_DDR_C1		DDR	
B10	DDR1_CA3	DDR1_CA3		IO	1.1 V					VDDS_DDR / VDDS_DDR_C1		DDR	
D10	DDR1_CA4	DDR1_CA4		IO	1.1 V					VDDS_DDR / VDDS_DDR_C1		DDR	
C9	DDR1_CA5	DDR1_CA5		IO	1.1 V					VDDS_DDR / VDDS_DDR_C1		DDR	
E8	DDR1_CAL0	DDR1_CAL0		A	1.1 V					VDDS_DDR / VDDS_DDR_C1		DDR	
B9	DDR1_CKE0	DDR1_CKE0		IO	1.1 V					VDDS_DDR / VDDS_DDR_C1		DDR	
D9	DDR1_CKE1	DDR1_CKE1		IO	1.1 V					VDDS_DDR / VDDS_DDR_C1		DDR	
F9	DDR1_CSn0_0	DDR1_CSn0_0		IO	1.1 V					VDDS_DDR / VDDS_DDR_C1		DDR	
F8	DDR1_CSn0_1	DDR1_CSn0_1		IO	1.1 V					VDDS_DDR / VDDS_DDR_C1		DDR	
F11	DDR1_CSn1_0	DDR1_CSn1_0		IO	1.1 V					VDDS_DDR / VDDS_DDR_C1		DDR	
F10	DDR1_CSn1_1	DDR1_CSn1_1		IO	1.1 V					VDDS_DDR / VDDS_DDR_C1		DDR	
D16	DDR1_DM0	DDR1_DM0		IO	1.1 V					VDDS_DDR / VDDS_DDR_C1		DDR	
E13	DDR1_DM1	DDR1_DM1		IO	1.1 V					VDDS_DDR / VDDS_DDR_C1		DDR	
F7	DDR1_DM2	DDR1_DM2		IO	1.1 V					VDDS_DDR / VDDS_DDR_C1		DDR	

表 6-1. Pin Attributes (ALZ Package) (continued)

Ball Num [1]	Ball Name [2] PADCFG Register [15] PADCFG Address [16]	Signal Name [3]	Mux Mode [4]	Signal Type [5]	I/O Voltage [6]	Ball State DURING Reset (RX/TX/PULL) [7]	Ball State AFTER Reset (RX/TX/PULL) [8]	Mux Mode AFTER Reset [9]	Pull Type [10]	Power [11]	Hys [12]	Voltage Buffer Type [13]	IO RET [14]
B3	DDR1_DM3	DDR1_DM3		IO	1.1 V					VDDS_DDR / VDDS_DDR_C1		DDR	
B18	DDR1_DQ0	DDR1_DQ0		IO	1.1 V					VDDS_DDR / VDDS_DDR_C1		DDR	
E17	DDR1_DQ1	DDR1_DQ1		IO	1.1 V					VDDS_DDR / VDDS_DDR_C1		DDR	
D18	DDR1_DQ2	DDR1_DQ2		IO	1.1 V					VDDS_DDR / VDDS_DDR_C1		DDR	
A17	DDR1_DQ3	DDR1_DQ3		IO	1.1 V					VDDS_DDR / VDDS_DDR_C1		DDR	
E15	DDR1_DQ4	DDR1_DQ4		IO	1.1 V					VDDS_DDR / VDDS_DDR_C1		DDR	
B16	DDR1_DQ5	DDR1_DQ5		IO	1.1 V					VDDS_DDR / VDDS_DDR_C1		DDR	
C15	DDR1_DQ6	DDR1_DQ6		IO	1.1 V					VDDS_DDR / VDDS_DDR_C1		DDR	
C17	DDR1_DQ7	DDR1_DQ7		IO	1.1 V					VDDS_DDR / VDDS_DDR_C1		DDR	
B14	DDR1_DQ8	DDR1_DQ8		IO	1.1 V					VDDS_DDR / VDDS_DDR_C1		DDR	
D14	DDR1_DQ9	DDR1_DQ9		IO	1.1 V					VDDS_DDR / VDDS_DDR_C1		DDR	
C13	DDR1_DQ10	DDR1_DQ10		IO	1.1 V					VDDS_DDR / VDDS_DDR_C1		DDR	
C11	DDR1_DQ11	DDR1_DQ11		IO	1.1 V					VDDS_DDR / VDDS_DDR_C1		DDR	
E11	DDR1_DQ12	DDR1_DQ12		IO	1.1 V					VDDS_DDR / VDDS_DDR_C1		DDR	
A11	DDR1_DQ13	DDR1_DQ13		IO	1.1 V					VDDS_DDR / VDDS_DDR_C1		DDR	
B12	DDR1_DQ14	DDR1_DQ14		IO	1.1 V					VDDS_DDR / VDDS_DDR_C1		DDR	

表 6-1. Pin Attributes (ALZ Package) (continued)

Ball Num [1]	Ball Name [2] PADCFG Register [15] PADCFG Address [16]	Signal Name [3]	Mux Mode [4]	Signal Type [5]	I/O Voltage [6]	Ball State DURING Reset (RX/TX/PULL) [7]	Ball State AFTER Reset (RX/TX/PULL) [8]	Mux Mode AFTER Reset [9]	Pull Type [10]	Power [11]	Hys [12]	Voltage Buffer Type [13]	IO RET [14]
D12	DDR1_DQ15	DDR1_DQ15		IO	1.1 V					VDDS_DDR / VDDS_DDR_C1		DDR	
B7	DDR1_DQ16	DDR1_DQ16		IO	1.1 V					VDDS_DDR / VDDS_DDR_C1		DDR	
D7	DDR1_DQ17	DDR1_DQ17		IO	1.1 V					VDDS_DDR / VDDS_DDR_C1		DDR	
C8	DDR1_DQ18	DDR1_DQ18		IO	1.1 V					VDDS_DDR / VDDS_DDR_C1		DDR	
A8	DDR1_DQ19	DDR1_DQ19		IO	1.1 V					VDDS_DDR / VDDS_DDR_C1		DDR	
C6	DDR1_DQ20	DDR1_DQ20		IO	1.1 V					VDDS_DDR / VDDS_DDR_C1		DDR	
E6	DDR1_DQ21	DDR1_DQ21		IO	1.1 V					VDDS_DDR / VDDS_DDR_C1		DDR	
B5	DDR1_DQ22	DDR1_DQ22		IO	1.1 V					VDDS_DDR / VDDS_DDR_C1		DDR	
D5	DDR1_DQ23	DDR1_DQ23		IO	1.1 V					VDDS_DDR / VDDS_DDR_C1		DDR	
B1	DDR1_DQ24	DDR1_DQ24		IO	1.1 V					VDDS_DDR / VDDS_DDR_C1		DDR	
A4	DDR1_DQ25	DDR1_DQ25		IO	1.1 V					VDDS_DDR / VDDS_DDR_C1		DDR	
C4	DDR1_DQ26	DDR1_DQ26		IO	1.1 V					VDDS_DDR / VDDS_DDR_C1		DDR	
E4	DDR1_DQ27	DDR1_DQ27		IO	1.1 V					VDDS_DDR / VDDS_DDR_C1		DDR	
D1	DDR1_DQ28	DDR1_DQ28		IO	1.1 V					VDDS_DDR / VDDS_DDR_C1		DDR	
D3	DDR1_DQ29	DDR1_DQ29		IO	1.1 V					VDDS_DDR / VDDS_DDR_C1		DDR	
C2	DDR1_DQ30	DDR1_DQ30		IO	1.1 V					VDDS_DDR / VDDS_DDR_C1		DDR	

表 6-1. Pin Attributes (ALZ Package) (continued)

Ball Num [1]	Ball Name [2] PADCFG Register [15] PADCFG Address [16]	Signal Name [3]	Mux Mode [4]	Signal Type [5]	I/O Voltage [6]	Ball State DURING Reset (RX/TX/PULL) [7]	Ball State AFTER Reset (RX/TX/PULL) [8]	Mux Mode AFTER Reset [9]	Pull Type [10]	Power [11]	Hys [12]	Voltage Buffer Type [13]	IO RET [14]
E2	DDR1_DQ31	DDR1_DQ31		IO	1.1 V					VDDS_DDR / VDDS_DDR_C1		DDR	
A15	DDR1_DQS0N	DDR1_DQS0N		IO	1.1 V					VDDS_DDR / VDDS_DDR_C1		DDR	
A16	DDR1_DQS0P	DDR1_DQS0P		IO	1.1 V					VDDS_DDR / VDDS_DDR_C1		DDR	
A12	DDR1_DQS1N	DDR1_DQS1N		IO	1.1 V					VDDS_DDR / VDDS_DDR_C1		DDR	
A13	DDR1_DQS1P	DDR1_DQS1P		IO	1.1 V					VDDS_DDR / VDDS_DDR_C1		DDR	
A7	DDR1_DQS2N	DDR1_DQS2N		IO	1.1 V					VDDS_DDR / VDDS_DDR_C1		DDR	
A6	DDR1_DQS2P	DDR1_DQS2P		IO	1.1 V					VDDS_DDR / VDDS_DDR_C1		DDR	
A2	DDR1_DQS3N	DDR1_DQS3N		IO	1.1 V					VDDS_DDR / VDDS_DDR_C1		DDR	
A3	DDR1_DQS3P	DDR1_DQS3P		IO	1.1 V					VDDS_DDR / VDDS_DDR_C1		DDR	
AG11	DP0_AUXN	DP0_AUXN		IO	1.8 V					VDDA_1P8_S ERDES2_4		AUX-PHY	
AF11	DP0_AUXP	DP0_AUXP		IO	1.8 V					VDDA_1P8_S ERDES2_4		AUX-PHY	
AH13	DSIO_TXCLKN	DSIO_TXCLKN	0	O	1.8 V					VDDA_0P8_D SITX / VDDA_0P8_D SITX_C / VDDA_1P8_D SITX		D-PHY	
		CSI0_TXCLKN	1	O									
AH14	DSIO_TXCLKP	DSIO_TXCLKP	0	O	1.8 V					VDDA_0P8_D SITX / VDDA_0P8_D SITX_C / VDDA_1P8_D SITX		D-PHY	
		CSI0_TXCLKP	1	O									
AC13	DSIO_TXRCALIB	DSIO_TXRCALIB		A	1.8 V					VDDA_0P8_D SITX / VDDA_0P8_D SITX_C / VDDA_1P8_D SITX		D-PHY	

表 6-1. Pin Attributes (ALZ Package) (continued)

Ball Num [1]	Ball Name [2] PADCFG Register [15] PADCFG Address [16]	Signal Name [3]	Mux Mode [4]	Signal Type [5]	I/O Voltage [6]	Ball State DURING Reset (RX/TX/PULL) [7]	Ball State AFTER Reset (RX/TX/PULL) [8]	Mux Mode AFTER Reset [9]	Pull Type [10]	Power [11]	Hys [12]	Voltage Buffer Type [13]	IO RET [14]
AH16	DSI1_TXCLKN	DSI1_TXCLKN	0	O	1.8 V					VDDA_0P8_D SITX / VDDA_0P8_D SITX_C / VDDA_1P8_D SITX		D-PHY	
		CSI1_TXCLKN	1	O									
AH17	DSI1_TXCLKP	DSI1_TXCLKP	0	O	1.8 V					VDDA_0P8_D SITX / VDDA_0P8_D SITX_C / VDDA_1P8_D SITX		D-PHY	
		CSI1_TXCLKP	1	O									
AC15	DSI1_TXRCALIB	DSI1_TXRCALIB		A	1.8 V					VDDA_0P8_D SITX / VDDA_0P8_D SITX_C / VDDA_1P8_D SITX		D-PHY	
AG12	DSI0_TXN0	DSI0_TXN0	0	IO	1.8 V					VDDA_0P8_D SITX / VDDA_0P8_D SITX_C / VDDA_1P8_D SITX		D-PHY	
		CSI0_TXN0	1	O									
AF13	DSI0_TXN1	DSI0_TXN1	0	O	1.8 V					VDDA_0P8_D SITX / VDDA_0P8_D SITX_C / VDDA_1P8_D SITX		D-PHY	
		CSI0_TXN1	1	O									
AE12	DSI0_TXN2	DSI0_TXN2	0	O	1.8 V					VDDA_0P8_D SITX / VDDA_0P8_D SITX_C / VDDA_1P8_D SITX		D-PHY	
		CSI0_TXN2	1	O									
AD13	DSI0_TXN3	DSI0_TXN3	0	O	1.8 V					VDDA_0P8_D SITX / VDDA_0P8_D SITX_C / VDDA_1P8_D SITX		D-PHY	
		CSI0_TXN3	1	O									
AG13	DSI0_TXP0	DSI0_TXP0	0	IO	1.8 V					VDDA_0P8_D SITX / VDDA_0P8_D SITX_C / VDDA_1P8_D SITX		D-PHY	
		CSI0_TXP0	1	O									

表 6-1. Pin Attributes (ALZ Package) (continued)

Ball Num [1]	Ball Name [2] PADCFG Register [15] PADCFG Address [16]	Signal Name [3]	Mux Mode [4]	Signal Type [5]	I/O Voltage [6]	Ball State DURING Reset (RX/TX/PULL) [7]	Ball State AFTER Reset (RX/TX/PULL) [8]	Mux Mode AFTER Reset [9]	Pull Type [10]	Power [11]	Hys [12]	Voltage Buffer Type [13]	IO RET [14]
AF14	DSI0_TXP1	DSI0_TXP1	0	O	1.8 V					VDDA_0P8_D SITX /		D-PHY	
		CSI0_TXP1	1	O						VDDA_0P8_D SITX_C / VDDA_1P8_D SITX			
AE13	DSI0_TXP2	DSI0_TXP2	0	O	1.8 V					VDDA_0P8_D SITX /		D-PHY	
		CSI0_TXP2	1	O						VDDA_0P8_D SITX_C / VDDA_1P8_D SITX			
AD14	DSI0_TXP3	DSI0_TXP3	0	O	1.8 V					VDDA_0P8_D SITX /		D-PHY	
		CSI0_TXP3	1	O						VDDA_0P8_D SITX_C / VDDA_1P8_D SITX			
AG15	DSI1_TXN0	DSI1_TXN0	0	IO	1.8 V					VDDA_0P8_D SITX /		D-PHY	
		CSI1_TXN0	1	O						VDDA_0P8_D SITX_C / VDDA_1P8_D SITX			
AF16	DSI1_TXN1	DSI1_TXN1	0	O	1.8 V					VDDA_0P8_D SITX /		D-PHY	
		CSI1_TXN1	1	O						VDDA_0P8_D SITX_C / VDDA_1P8_D SITX			
AE15	DSI1_TXN2	DSI1_TXN2	0	O	1.8 V					VDDA_0P8_D SITX /		D-PHY	
		CSI1_TXN2	1	O						VDDA_0P8_D SITX_C / VDDA_1P8_D SITX			
AD16	DSI1_TXN3	DSI1_TXN3	0	O	1.8 V					VDDA_0P8_D SITX /		D-PHY	
		CSI1_TXN3	1	O						VDDA_0P8_D SITX_C / VDDA_1P8_D SITX			
AG16	DSI1_TXP0	DSI1_TXP0	0	IO	1.8 V					VDDA_0P8_D SITX /		D-PHY	
		CSI1_TXP0	1	O						VDDA_0P8_D SITX_C / VDDA_1P8_D SITX			

表 6-1. Pin Attributes (ALZ Package) (continued)

Ball Num [1]	Ball Name [2] PADCFG Register [15] PADCFG Address [16]	Signal Name [3]	Mux Mode [4]	Signal Type [5]	I/O Voltage [6]	Ball State DURING Reset (RX/TX/PULL) [7]	Ball State AFTER Reset (RX/TX/PULL) [8]	Mux Mode AFTER Reset [9]	Pull Type [10]	Power [11]	Hys [12]	Voltage Buffer Type [13]	IO RET [14]
AF17	DSI1_TXP1	DSI1_TXP1	0	O	1.8 V					VDDA_0P8_D SITX / VDDA_0P8_D SITX_C / VDDA_1P8_D SITX		D-PHY	
		CSI1_TXP1	1	O									
AE16	DSI1_TXP2	DSI1_TXP2	0	O	1.8 V					VDDA_0P8_D SITX / VDDA_0P8_D SITX_C / VDDA_1P8_D SITX		D-PHY	
		CSI1_TXP2	1	O									
AD17	DSI1_TXP3	DSI1_TXP3	0	O	1.8 V					VDDA_0P8_D SITX / VDDA_0P8_D SITX_C / VDDA_1P8_D SITX		D-PHY	
		CSI1_TXP3	1	O									
AB26	ECAP0_IN_APWM_OUT PADCFG: PADCONFIG_49 0x0011C0C4	ECAP0_IN_APWM_OUT	0	IO	1.8 V/3.3 V	Off / Off / Off	Off / Off / Off	7	PU/PD	VDDSHV2	Yes	LVCMOS	Yes
		MCASP4_AXR2	1	IO									
		CPTS0_RFT_CLK	2	I									
		HYP1_TXFLCLK	3	I									
		MCAN12_TX	4	O									
		VOUT0_DATA23	5	O									
		GPMC0_AD5	6	IO									
		GPIO0_49	7	IO									
		SPI6_D0	8	IO									
		SYNC0_OUT	9	O									
		TRC_DATA1	10	O									
		UART2_CTSn	11	I									
		CPTS0_HW1TSPUSH	12	I									
		I2C1_SCL	13	IOD									
UART3_RXD	14	I											
A27	EMU0 PADCFG: WKUP_PADCONFIG_75 0x4301C12C	EMU0	0	IO	1.8 V/3.3 V	On / Off / Up	On / Off / Up	0	PU/PD	VDDSHV0_M CU	Yes	LVCMOS	No
C26	EMU1 PADCFG: WKUP_PADCONFIG_76 0x4301C130	EMU1	0	IO	1.8 V/3.3 V	On / Off / Up	On / Off / Up	0	PU/PD	VDDSHV0_M CU	Yes	LVCMOS	No
		MCU_OBSCLK0	15	O									
AG24	EXTINTn PADCFG: PADCONFIG_0 0x0011C000	EXTINTn	0	I	1.8 V/3.3 V	Off / Off / Off	Off / SS / Off	7		VDDSHV0	Yes	I2C OPEN DRAIN	No
		GPIO0_0	7	IO									

表 6-1. Pin Attributes (ALZ Package) (continued)

Ball Num [1]	Ball Name [2] PADCFG Register [15] PADCFG Address [16]	Signal Name [3]	Mux Mode [4]	Signal Type [5]	I/O Voltage [6]	Ball State DURING Reset (RX/TX/PULL) [7]	Ball State AFTER Reset (RX/TX/PULL) [8]	Mux Mode AFTER Reset [9]	Pull Type [10]	Power [11]	Hys [12]	Voltage Buffer Type [13]	IO RET [14]
AD28	EXT_REFCLK1 PADCFG: PADCONFIG_50 0x0011C0C8	EXT_REFCLK1	0	I	1.8 V/3.3 V	Off / Off / Off	Off / Off / Off	7	PU/PD	VDDSHV2	Yes	LVC MOS	Yes
		MCASP4_ACLKX	1	IO									
		VOU0_DATA16	2	O									
		HYP1_TXFLDAT	3	I									
		MCAN1_RX	4	I									
		GPMC0_AD6	6	IO									
		GPIO0_50	7	IO									
		SYNC1_OUT	9	O									
		TRC_CLK	10	O									
		UART2_RTSn	11	O									
		CPTS0_HW2TSPUSH	12	I									
		I2C1_SDA	13	IOD									
		UART3_TXD	14	O									
		V23	GPIO0_11 PADCFG: PADCONFIG_11 0x0011C02C	MCAN17_TX									
VOU0_DATA18	2			O									
GPMC0_A14	6			OZ									
GPIO0_11	7			IO									
SPI7_CS3	8			IO									
TRC_DATA25	10			O									
GPMC0_CSn2	12			O									
UART7_RXD	13			I									
USB0_DRVVBUS	14			O									
T26	GPIO0_12 PADCFG: PADCONFIG_12 0x0011C030	MCAN12_RX	0	I	1.8 V/3.3 V	Off / Off / Off	Off / Off / Off	7	PU/PD	VDDSHV2	Yes	LVC MOS	Yes
		VOU0_DATA17	2	O									
		HYP1_RXFLDAT	3	O									
		VOU0_DATA22	5	O									
		GPMC0_AD4	6	IO									
		GPIO0_12	7	IO									
		SPI6_CLK	8	IO									
		EQEP1_I	9	IO									
		TRC_DATA2	10	O									
		UART9_CTSn	11	I									
		UART6_RXD	12	I									
AH25	I2C0_SCL PADCFG: PADCONFIG_56 0x0011C0E0	I2C0_SCL	0	IOD	1.8 V/3.3 V	Off / Off / Off	On / SS / Off	7		VDDSHV0	Yes	I2C OPEN DRAIN	No
		GPIO0_56	7	IO									

**表 6-1. Pin Attributes (ALZ Package) (continued)**

Ball Num [1]	Ball Name [2] PADCFG Register [15] PADCFG Address [16]	Signal Name [3]	Mux Mode [4]	Signal Type [5]	I/O Voltage [6]	Ball State DURING Reset (RX/TX/PULL) [7]	Ball State AFTER Reset (RX/TX/PULL) [8]	Mux Mode AFTER Reset [9]	Pull Type [10]	Power [11]	Hys [12]	Voltage Buffer Type [13]	IO RET [14]
AE24	I2C0_SDA PADCFG: PADCONFIG_57 0x0011C0E4	I2C0_SDA	0	IOD	1.8 V/3.3 V	Off / Off / Off	On / SS / Off	7		VDDSHV0	Yes	I2C OPEN DRAIN	No
		GPIO0_57	7	IO									
U28	MCAN0_RX PADCFG: PADCONFIG_26 0x0011C068	MCAN0_RX	0	I	1.8 V/3.3 V	Off / Off / Off	Off / Off / Off	7	PU/PD	VDDSHV2	Yes	LVC MOS	Yes
		MCASP4_AXR1	1	IO									
		VOUT0_DATA3	2	O									
		GPMC0_AD15	6	IO									
		GPIO0_26	7	IO									
		SPI5_CS0	8	IO									
		EHRPWM0_A	9	IO									
		TRC_DATA16	10	O									
		UART2_TXD	11	O									
		UART6_RTSn	12	O									
SPI7_D0	13	IO											
W28	MCAN0_TX PADCFG: PADCONFIG_25 0x0011C064	MCAN0_TX	0	O	1.8 V/3.3 V	Off / Off / Off	Off / Off / Off	7	PU/PD	VDDSHV2	Yes	LVC MOS	Yes
		MCASP2_AXR2	1	IO									
		VOUT0_DATA4	2	O									
		GPMC0_AD14	6	IO									
		GPIO0_25	7	IO									
		SPI5_CS1	8	IO									
		EHRPWM0_B	9	IO									
		TRC_DATA11	10	O									
		UART2_RXD	11	I									
		UART6_CTSn	12	I									
I2C3_SCL	13	IOD											
R27	MCAN1_RX PADCFG: PADCONFIG_28 0x0011C070	MCAN1_RX	0	I	1.8 V/3.3 V	Off / Off / Off	Off / Off / Off	7	PU/PD	VDDSHV2	Yes	LVC MOS	Yes
		MCASP4_AXR3	1	IO									
		VOUT0_DATA1	2	O									
		VOUT0_DATA19	5	O									
		GPMC0_BE0n_CLE	6	O									
		GPIO0_28	7	IO									
		SPI5_D0	8	IO									
		EHRPWM0_SYNCI	9	I									
		TRC_DATA5	10	O									
UART3_RTSn	11	O											

表 6-1. Pin Attributes (ALZ Package) (continued)

Ball Num [1]	Ball Name [2] PADCFG Register [15] PADCFG Address [16]	Signal Name [3]	Mux Mode [4]	Signal Type [5]	I/O Voltage [6]	Ball State DURING Reset (RX/TX/PULL) [7]	Ball State AFTER Reset (RX/TX/PULL) [8]	Mux Mode AFTER Reset [9]	Pull Type [10]	Power [11]	Hys [12]	Voltage Buffer Type [13]	IO RET [14]											
V26	MCAN1_TX PADCFG: PADCONFIG_27 0x0011C06C	MCAN1_TX	0	O	1.8 V/3.3 V	Off / Off / Off	Off / Off / Off	7	PU/PD	VDDSHV2	Yes	LVCMOS	Yes											
		MCASP4_AFSX	1	IO																				
		VOUT0_EXTPLCKIN	2	I																				
		HYP1_TXPMCLK	3	O																				
		DSS_FSYNCO	4	O																				
		GPMC0_AD7	6	IO																				
		GPIO0_27	7	IO																				
		EHRPWM_TZn_IN5	9	I																				
		TRC_CTL	10	O																				
		UART6_TXD	11	O																				
Y25	MCAN2_RX PADCFG: PADCONFIG_30 0x0011C078	MCAN2_RX	0	I	1.8 V/3.3 V	Off / Off / Off	Off / Off / Off	7	PU/PD	VDDSHV2	Yes	LVCMOS	Yes											
		AUDIO_EXT_REFCLK1	1	IO																				
		VOUT0_PCLK	2	O																				
		GPMC0_CSn1	6	O																				
		GPIO0_30	7	IO																				
		SPI6_CS1	8	IO																				
		EHRPWM4_B	9	IO																				
		TRC_DATA17	10	O																				
		UART3_TXD	11	O																				
		GPMC0_DIR	12	O																				
		I2C5_SDA	13	IOD																				
		R28	MCAN2_TX PADCFG: PADCONFIG_29 0x0011C074	MCAN2_TX										0	O	1.8 V/3.3 V	Off / Off / Off	Off / Off / Off	7	PU/PD	VDDSHV2	Yes	LVCMOS	Yes
				MCASP2_AXR3										1	IO									
VOUT0_DATA0	2			O																				
VOUT0_DATA18	5			O																				
GPMC0_WAIT0	6			I																				
GPIO0_29	7			IO																				
SPI6_D1	8			IO																				
EHRPWM1_B	9			IO																				
TRC_DATA3	10			O																				
UART3_RXD	11			I																				
GPMC0_DIR	12			O																				
I2C5_SCL	13			IOD																				

**表 6-1. Pin Attributes (ALZ Package) (continued)**

Ball Num [1]	Ball Name [2] PADCFG Register [15] PADCFG Address [16]	Signal Name [3]	Mux Mode [4]	Signal Type [5]	I/O Voltage [6]	Ball State DURING Reset (RX/TX/PULL) [7]	Ball State AFTER Reset (RX/TX/PULL) [8]	Mux Mode AFTER Reset [9]	Pull Type [10]	Power [11]	Hys [12]	Voltage Buffer Type [13]	IO RET [14]
AC24	MCAN12_RX PADCFG: PADCONFIG_2 0x0011C008	MCAN12_RX	0	I	1.8 V/3.3 V	Off / Off / Off	Off / Off / Off	7	PU/PD	VDDSHV2	Yes	LVCMOS	Yes
		UART0_DCDn	1	I									
		DSS_FSYNC1	3	O									
		GPMC0_A23	6	OZ									
		GPIO0_2	7	IO									
		TRC_CTL	10	O									
		UART5_RXD	11	I									
GPMC0_CSn3	12	O											
W25	MCAN12_TX PADCFG: PADCONFIG_1 0x0011C004	MCAN12_TX	0	O	1.8 V/3.3 V	Off / Off / Off	Off / Off / Off	7	PU/PD	VDDSHV2	Yes	LVCMOS	Yes
		DSS_FSYNC0	3	O									
		GPMC0_A24	6	OZ									
		GPIO0_1	7	IO									
		TRC_CLK	10	O									
		UART5_TXD	11	O									
GPMC0_CLK	12	IO											
AF28	MCAN13_RX PADCFG: PADCONFIG_4 0x0011C010	MCAN13_RX	0	I	1.8 V/3.3 V	Off / Off / Off	Off / Off / Off	7	PU/PD	VDDSHV2	Yes	LVCMOS	Yes
		UART0_DTRn	1	O									
		DSS_FSYNC3	3	O									
		GPMC0_A21	6	OZ									
		GPIO0_4	7	IO									
		I2C4_SDA	8	IOD									
		TRC_DATA1	10	O									
UART6_TXD	11	O											
AE28	MCAN13_TX PADCFG: PADCONFIG_3 0x0011C00C	MCAN13_TX	0	O	1.8 V/3.3 V	Off / Off / Off	Off / Off / Off	7	PU/PD	VDDSHV2	Yes	LVCMOS	Yes
		UART0_DSRn	1	I									
		DSS_FSYNC2	3	O									
		GPMC0_A22	6	OZ									
		GPIO0_3	7	IO									
		TRC_DATA0	10	O									
		UART4_TXD	11	O									
GPMC0_WAIT2	12	I											

表 6-1. Pin Attributes (ALZ Package) (continued)

Ball Num [1]	Ball Name [2] PADCFG Register [15] PADCFG Address [16]	Signal Name [3]	Mux Mode [4]	Signal Type [5]	I/O Voltage [6]	Ball State DURING Reset (RX/TX/PULL) [7]	Ball State AFTER Reset (RX/TX/PULL) [8]	Mux Mode AFTER Reset [9]	Pull Type [10]	Power [11]	Hys [12]	Voltage Buffer Type [13]	IO RET [14]
W23	MCAN14_RX PADCFG: PADCONFIG_6 0x0011C018	MCAN14_RX	0	I	1.8 V/3.3 V	Off / Off / Off	Off / Off / Off	7	PU/PD	VDDSHV2	Yes	LVC MOS	Yes
		VOUT0_DATA23	2	O									
		GPMC0_A19	6	OZ									
		GPIO0_6	7	IO									
		I2C5_SDA	8	IOD									
		TRC_DATA3	10	O									
		UART9_TXD	11	O									
AD25	MCAN14_TX PADCFG: PADCONFIG_5 0x0011C014	MCAN14_TX	0	O	1.8 V/3.3 V	Off / Off / Off	Off / Off / Off	7	PU/PD	VDDSHV2	Yes	LVC MOS	Yes
		UART0_RIn	1	I									
		GPMC0_A20	6	OZ									
		GPIO0_5	7	IO									
		I2C4_SCL	8	IOD									
		TRC_DATA2	10	O									
		UART6_RXD	11	I									
AA23	MCAN15_RX PADCFG: PADCONFIG_8 0x0011C020	MCAN15_RX	0	I	1.8 V/3.3 V	Off / Off / Off	Off / Off / Off	7	PU/PD	VDDSHV2	Yes	LVC MOS	Yes
		VOUT0_DATA21	2	O									
		GPMC0_A17	6	OZ									
		GPIO0_8	7	IO									
		SPI0_CS2	8	IO									
		TRC_DATA22	10	O									
		I2C1_SCL	12	IOD									
Y24	MCAN15_TX PADCFG: PADCONFIG_7 0x0011C01C	MCAN15_TX	0	O	1.8 V/3.3 V	Off / Off / Off	Off / Off / Off	7	PU/PD	VDDSHV2	Yes	LVC MOS	Yes
		VOUT0_DATA22	2	O									
		GPMC0_A18	6	OZ									
		GPIO0_7	7	IO									
		I2C5_SCL	8	IOD									
		TRC_DATA21	10	O									
		UART9_RXD	11	I									
AB24	MCAN16_RX PADCFG: PADCONFIG_10 0x0011C028	MCAN16_RX	0	I	1.8 V/3.3 V	Off / Off / Off	Off / Off / Off	7	PU/PD	VDDSHV2	Yes	LVC MOS	Yes
		VOUT0_DATA19	2	O									
		GPMC0_A15	6	OZ									
		GPIO0_10	7	IO									
		SPI0_CS3	8	IO									
		TRC_DATA24	10	O									
		GPMC0_WAIT1	12	I									

**表 6-1. Pin Attributes (ALZ Package) (continued)**

Ball Num [1]	Ball Name [2] PADCFG Register [15] PADCFG Address [16]	Signal Name [3]	Mux Mode [4]	Signal Type [5]	I/O Voltage [6]	Ball State DURING Reset (RX/TX/PULL) [7]	Ball State AFTER Reset (RX/TX/PULL) [8]	Mux Mode AFTER Reset [9]	Pull Type [10]	Power [11]	Hys [12]	Voltage Buffer Type [13]	IO RET [14]
Y28	MCAN16_TX PADCFG: PADCONFIG_9 0x0011C024	MCAN16_TX	0	O	1.8 V/3.3 V	Off / Off / Off	Off / Off / Off	7	PU/PD	VDDSHV2	Yes	LVC MOS	Yes
		VOUT0_DATA20	2	O									
		GPMC0_A16	6	OZ									
		GPIO0_9	7	IO									
		SPI1_CS3	8	IO									
		TRC_DATA23	10	O									
		I2C1_SDA	12	IOD									
AB28	MCASP0_ACLKX PADCFG: PADCONFIG_14 0x0011C038	MCAN5_TX	0	O	1.8 V/3.3 V	Off / Off / Off	Off / Off / Off	7	PU/PD	VDDSHV2	Yes	LVC MOS	Yes
		MCASP0_ACLKX	1	IO									
		VOUT0_DATA15	2	O									
		HYP0_RXFLCLK	3	O									
		GPMC0_AD0	6	IO									
		GPIO0_14	7	IO									
		EHRPWM_TZn_IN2	9	I									
UART8_RXD	11	I											
U27	MCASP0_AFSX PADCFG: PADCONFIG_15 0x0011C03C	MCAN5_RX	0	I	1.8 V/3.3 V	Off / Off / Off	Off / Off / Off	7	PU/PD	VDDSHV2	Yes	LVC MOS	Yes
		MCASP0_AFSX	1	IO									
		VOUT0_DATA14	2	O									
		HYP0_RXFLDAT	3	O									
		GPMC0_AD1	6	IO									
		GPIO0_15	7	IO									
		EHRPWM2_B	9	IO									
UART8_TXD	11	O											
AA24	MCASP1_ACLKX PADCFG: PADCONFIG_46 0x0011C0B8	MCAN10_RX	0	I	1.8 V/3.3 V	Off / Off / Off	Off / Off / Off	7	PU/PD	VDDSHV2	Yes	LVC MOS	Yes
		MCASP1_ACLKX	1	IO									
		DP0_HPDI	3	I									
		GPMC0_A11	5	OZ									
		RGMI1_RD0	6	I									
		GPIO0_46	7	IO									
		EQEP0_S	9	IO									
		UART4_RTSn	11	O									
SPI3_CS3	12	IO											
UART9_RTSn	13	O											

表 6-1. Pin Attributes (ALZ Package) (continued)

Ball Num [1]	Ball Name [2] PADCFG Register [15] PADCFG Address [16]	Signal Name [3]	Mux Mode [4]	Signal Type [5]	I/O Voltage [6]	Ball State DURING Reset (RX/TX/PULL) [7]	Ball State AFTER Reset (RX/TX/PULL) [8]	Mux Mode AFTER Reset [9]	Pull Type [10]	Power [11]	Hys [12]	Voltage Buffer Type [13]	IO RET [14]
V28	MCASP1_AFSX PADCFG: PADCONFIG_47 0x0011C0BC	MCAN11_TX	0	O	1.8 V/3.3 V	Off / Off / Off	Off / Off / Off	7	PU/PD	VDDSHV2	Yes	LVCMOS	Yes
		MCASP1_AFSX	1	IO									
		GPMC0_A12	5	OZ									
		MDIO0_MDIO	6	IO									
		GPIO0_47	7	IO									
		SPI3_CS0	8	IO									
		EQEP0_I	9	IO									
		UART0_RXD	11	I									
Y27	MCASP2_ACLKX PADCFG: PADCONFIG_21 0x0011C054	MCAN8_RX	0	I	1.8 V/3.3 V	Off / Off / Off	Off / Off / Off	7	PU/PD	VDDSHV2	Yes	LVCMOS	Yes
		MCASP2_ACLKX	1	IO									
		VOUT0_DATA8	2	O									
		HYP0_TXPMCLK	3	O									
		VOUT0_DATA20	5	O									
		GPMC0_AD10	6	IO									
		GPIO0_21	7	IO									
		SPI5_CS2	8	IO									
		EQEP2_S	9	IO									
		TRC_DATA4	10	O									
		UART1_RXD	11	I									
		SPI7_CS1	13	IO									
		SYNC3_OUT	14	O									
		AA27	MCASP2_AFSX PADCFG: PADCONFIG_22 0x0011C058	MCAN9_TX									
MCASP2_AFSX	1			IO									
VOUT0_DATA7	2			O									
HYP0_TXPMDAT	3			O									
GPMC0_AD11	6			IO									
GPIO0_22	7			IO									
SPI5_CS3	8			IO									
EHRPWM_SOCA	9			O									
TRC_DATA9	10			O									
UART1_TXD	11			O									
SPI7_CS2	13			IO									

**表 6-1. Pin Attributes (ALZ Package) (continued)**

Ball Num [1]	Ball Name [2] PADCFG Register [15] PADCFG Address [16]	Signal Name [3]	Mux Mode [4]	Signal Type [5]	I/O Voltage [6]	Ball State DURING Reset (RX/TX/PULL) [7]	Ball State AFTER Reset (RX/TX/PULL) [8]	Mux Mode AFTER Reset [9]	Pull Type [10]	Power [11]	Hys [12]	Voltage Buffer Type [13]	IO RET [14]
AC28	MCASP0_AXR0 PADCFG: PADCONFIG_16 0x0011C040	MCAN6_TX	0	O	1.8 V/3.3 V	Off / Off / Off	Off / Off / Off	7	PU/PD	VDDSHV2	Yes	LVC MOS	Yes
		MCASP0_AXR0	1	IO									
		VOU0_DATA13	2	O									
		HYP0_TXFLCLK	3	I									
		GPMC0_AD2	6	IO									
		GPIO0_16	7	IO									
		SPI2_CS2	8	IO									
		EHRPWM2_A	9	IO									
		TRC_DATA14	10	O									
		UART4_RXD	11	I									
		SPI7_CLK	13	IO									
		UART8_CTSn	14	I									
Y26	MCASP0_AXR1 PADCFG: PADCONFIG_17 0x0011C044	MCAN6_RX	0	I	1.8 V/3.3 V	Off / Off / Off	Off / Off / Off	7	PU/PD	VDDSHV2	Yes	LVC MOS	Yes
		MCASP0_AXR1	1	IO									
		VOU0_DATA12	2	O									
		HYP0_TXFLDAT	3	I									
		OBCLK1	4	O									
		GPMC0_AD3	6	IO									
		GPIO0_17	7	IO									
		SPI2_CS3	8	IO									
		EHRPWM0_SYNCO	9	O									
		TRC_DATA12	10	O									
		UART4_TXD	11	O									
		SPI7_CS0	13	IO									
UART8_RTSn	14	O											
AB27	MCASP0_AXR2 PADCFG: PADCONFIG_18 0x0011C048	MCAN7_TX	0	O	1.8 V/3.3 V	Off / Off / Off	Off / Off / Off	7	PU/PD	VDDSHV2	Yes	LVC MOS	Yes
		MCASP0_AXR2	1	IO									
		VOU0_DATA11	2	O									
		HYP1_RXFLCLK	3	O									
		GPMC0_ADVn_ALE	6	O									
		GPIO0_18	7	IO									
		EQEP2_A	9	I									
		TRC_DATA10	10	O									
		UART4_CTSn	11	I									
		GPMC0_WPn	12	O									
UART9_CTSn	13	I											

表 6-1. Pin Attributes (ALZ Package) (continued)

Ball Num [1]	Ball Name [2] PADCFG Register [15] PADCFG Address [16]	Signal Name [3]	Mux Mode [4]	Signal Type [5]	I/O Voltage [6]	Ball State DURING Reset (RX/TX/PULL) [7]	Ball State AFTER Reset (RX/TX/PULL) [8]	Mux Mode AFTER Reset [9]	Pull Type [10]	Power [11]	Hys [12]	Voltage Buffer Type [13]	IO RET [14]
T27	MCASP0_AXR3 PADCFG: PADCONFIG_31 0x0011C07C	MCAN3_TX	0	O	1.8 V/3.3 V	Off / Off / Off	Off / Off / Off	7	PU/PD	VDDSHV2	Yes	LVC MOS	Yes
		MCASP0_AXR3	1	IO									
		VOUT0_DATA2	2	O									
		GPMC0_BE1n	6	O									
		GPIO0_31	7	IO									
		SPI5_CLK	8	IO									
		EHRPWM_TZn_IN0	9	I									
		TRC_DATA7	10	O									
		UART3_CTSn	11	I									
		SPI3_CS1	12	IO									
		SPI7_D1	13	IO									
U26	MCASP0_AXR4 PADCFG: PADCONFIG_32 0x0011C080	MCAN3_RX	0	I	1.8 V/3.3 V	Off / Off / Off	Off / Off / Off	7	PU/PD	VDDSHV2	Yes	LVC MOS	Yes
		MCASP0_AXR4	1	IO									
		VOUT0_HSYNC	2	O									
		HYP1_TXPMDAT	3	O									
		VOUT0_VP0_HSYNC	4	O									
		VOUT0_VP2_HSYNC	5	O									
		GPMC0_OEn_REn	6	O									
		GPIO0_32	7	IO									
		SPI6_CS2	8	IO									
		EHRPWM5_B	9	IO									
		TRC_DATA18	10	O									
I2C4_SDA	13	IOD											
AA28	MCASP0_AXR5 PADCFG: PADCONFIG_33 0x0011C084	MCAN4_TX	0	O	1.8 V/3.3 V	Off / Off / Off	Off / Off / Off	7	PU/PD	VDDSHV2	Yes	LVC MOS	Yes
		MCASP0_AXR5	1	IO									
		VOUT0_DE	2	O									
		MCASP1_ACLKR	3	IO									
		VOUT0_VP0_DE	4	O									
		VOUT0_VP2_DE	5	O									
		GPMC0_CSn0	6	O									
		GPIO0_33	7	IO									
		SPI6_CS3	8	IO									
		EHRPWM5_A	9	IO									
		TRC_DATA19	10	O									
I2C4_SCL	13	IOD											

**表 6-1. Pin Attributes (ALZ Package) (continued)**

Ball Num [1]	Ball Name [2] PADCFG Register [15] PADCFG Address [16]	Signal Name [3]	Mux Mode [4]	Signal Type [5]	I/O Voltage [6]	Ball State DURING Reset (RX/TX/PULL) [7]	Ball State AFTER Reset (RX/TX/PULL) [8]	Mux Mode AFTER Reset [9]	Pull Type [10]	Power [11]	Hys [12]	Voltage Buffer Type [13]	IO RET [14]
AD27	MCASP0_AXR6 PADCFG: PADCONFIG_34 0x0011C088	MCAN4_RX	0	I	1.8 V/3.3 V	Off / Off / Off	Off / Off / Off	7	PU/PD	VDDSHV2	Yes	LVCMOS	Yes
		MCASP0_AXR6	1	IO									
		VOU0_VSYNC	2	O									
		MCASP1_AFSR	3	IO									
		VOU0_VP0_VSYNC	4	O									
		VOU0_VP2_VSYNC	5	O									
		GPMC0_CLKOUT	6	O									
		GPIO0_34	7	IO									
		SPI3_CS2	8	IO									
		EHRPWM_TZn_IN4	9	I									
		TRC_DATA20	10	O									
		SPI5_D1	11	IO									
		GPMC0_FCLK_MUX	12	O									
T25	MCASP0_AXR7 PADCFG: PADCONFIG_35 0x0011C08C	MCAN5_TX	0	O	1.8 V/3.3 V	Off / Off / Off	Off / Off / Off	7	PU/PD	VDDSHV2	Yes	LVCMOS	Yes
		MCASP0_AXR7	1	IO									
		MCASP4_ACLKR	3	IO									
		GPMC0_A0	5	OZ									
		RGMI1_TD0	6	O									
		GPIO0_35	7	IO									
		GPMC0_A14	8	OZ									
		EHRPWM3_A	9	IO									
		UART4_RXD	11	I									
		GPMC0_CSn2	12	O									
		USB0_DRVVBUS	14	O									
W24	MCASP0_AXR8 PADCFG: PADCONFIG_36 0x0011C090	MCAN5_RX	0	I	1.8 V/3.3 V	Off / Off / Off	Off / Off / Off	7	PU/PD	VDDSHV2	Yes	LVCMOS	Yes
		MCASP0_AXR8	1	IO									
		MCASP4_AFSR	3	IO									
		GPMC0_A1	5	OZ									
		RGMI1_TD1	6	O									
		GPIO0_36	7	IO									
		RMII1_RXD0	8	I									
		EHRPWM_TZn_IN3	9	I									
UART4_TXD	11	O											

表 6-1. Pin Attributes (ALZ Package) (continued)

Ball Num [1]	Ball Name [2] PADCFG Register [15] PADCFG Address [16]	Signal Name [3]	Mux Mode [4]	Signal Type [5]	I/O Voltage [6]	Ball State DURING Reset (RX/TX/PULL) [7]	Ball State AFTER Reset (RX/TX/PULL) [8]	Mux Mode AFTER Reset [9]	Pull Type [10]	Power [11]	Hys [12]	Voltage Buffer Type [13]	IO RET [14]
AA25	MCASP0_AXR9 PADCFG: PADCONFIG_37 0x0011C094	MCAN6_TX	0	O	1.8 V/3.3 V	Off / Off / Off	Off / Off / Off	7	PU/PD	VDDSHV2	Yes	LVC MOS	Yes
		MCASP0_AXR9	1	IO									
		MCASP4_AXR4	2	IO									
		GPMC0_A2	5	OZ									
		RGMI1_TD2	6	O									
		GPIO0_37	7	IO									
		RMII1_RXD1	8	I									
		EHRPWM3_SYNCO	9	O									
UART4_CTSn	11	I											
V25	MCASP0_AXR10 PADCFG: PADCONFIG_38 0x0011C098	MCAN6_RX	0	I	1.8 V/3.3 V	Off / Off / Off	Off / Off / Off	7	PU/PD	VDDSHV2	Yes	LVC MOS	Yes
		MCASP0_AXR10	1	IO									
		GPMC0_A3	5	OZ									
		RGMI1_TD3	6	O									
		GPIO0_38	7	IO									
		RMII1_CRS_DV	8	I									
		EHRPWM3_SYNCI	9	I									
		UART4_RTSn	11	O									
T24	MCASP0_AXR11 PADCFG: PADCONFIG_39 0x0011C09C	MCAN7_TX	0	O	1.8 V/3.3 V	Off / Off / Off	Off / Off / Off	7	PU/PD	VDDSHV2	Yes	LVC MOS	Yes
		MCASP0_AXR11	1	IO									
		GPMC0_A4	5	OZ									
		RGMI1_TX_CTL	6	O									
		GPIO0_39	7	IO									
		RMII1_RX_ER	8	I									
		EHRPWM3_B	9	IO									
		SPI2_CS1	10	IO									
UART5_RXD	11	I											
AB25	MCASP0_AXR12 PADCFG: PADCONFIG_40 0x0011C0A0	MCAN7_RX	0	I	1.8 V/3.3 V	Off / Off / Off	Off / Off / Off	7	PU/PD	VDDSHV2	Yes	LVC MOS	Yes
		MCASP0_AXR12	1	IO									
		MCASP2_ACLKR	3	IO									
		GPMC0_A5	5	OZ									
		RGMI1_RD1	6	I									
		GPIO0_40	7	IO									
		RMII1_TXD0	8	O									
		EHRPWM3_SOCB	9	O									
SPI2_CLK	10	IO											
UART5_TXD	11	O											

**表 6-1. Pin Attributes (ALZ Package) (continued)**

Ball Num [1]	Ball Name [2] PADCFG Register [15] PADCFG Address [16]	Signal Name [3]	Mux Mode [4]	Signal Type [5]	I/O Voltage [6]	Ball State DURING Reset (RX/TX/PULL) [7]	Ball State AFTER Reset (RX/TX/PULL) [8]	Mux Mode AFTER Reset [9]	Pull Type [10]	Power [11]	Hys [12]	Voltage Buffer Type [13]	IO RET [14]
T23	MCASP0_AXR13 PADCFG: PADCONFIG_41 0x0011C0A4	MCAN8_TX	0	O	1.8 V/3.3 V	Off / Off / Off	Off / Off / Off	7	PU/PD	VDDSHV2	Yes	LVC MOS	Yes
		MCASP0_AXR13	1	IO									
		MCASP2_AFSR	3	IO									
		GPMC0_A6	5	OZ									
		RGMII1_RD2	6	I									
		GPIO0_41	7	IO									
		RMII_REF_CLK	8	I									
		EHRPWM4_A	9	IO									
		SPI2_CS0	10	IO									
		UART5_CTSn	11	I									
		UART7_RXD	13	I									
U24	MCASP0_AXR14 PADCFG: PADCONFIG_42 0x0011C0A8	MCAN8_RX	0	I	1.8 V/3.3 V	Off / Off / Off	Off / Off / Off	7	PU/PD	VDDSHV2	Yes	LVC MOS	Yes
		MCASP0_AXR14	1	IO									
		MCASP2_AXR4	2	IO									
		MCASP0_ACLKR	3	IO									
		GPMC0_A7	5	OZ									
		RGMII1_RD3	6	I									
		GPIO0_42	7	IO									
		CLKOUT	8	IO									
		EQEP0_A	9	I									
		SPI2_D0	10	IO									
		UART5_RTSn	11	O									
UART7_TXD	13	O											
AC25	MCASP0_AXR15 PADCFG: PADCONFIG_43 0x0011C0AC	MCAN9_TX	0	O	1.8 V/3.3 V	Off / Off / Off	Off / Off / Off	7	PU/PD	VDDSHV2	Yes	LVC MOS	Yes
		MCASP0_AXR15	1	IO									
		MCASP0_AFSR	3	IO									
		GPMC0_A8	5	OZ									
		RGMII1_RX_CTL	6	I									
		GPIO0_43	7	IO									
		RMII1_TX_EN	8	O									
		EQEP0_B	9	I									
		SPI2_D1	10	IO									
		UART8_RXD	11	I									
		I2C1_SCL	13	IOD									

表 6-1. Pin Attributes (ALZ Package) (continued)

Ball Num [1]	Ball Name [2] PADCFG Register [15] PADCFG Address [16]	Signal Name [3]	Mux Mode [4]	Signal Type [5]	I/O Voltage [6]	Ball State DURING Reset (RX/TX/PULL) [7]	Ball State AFTER Reset (RX/TX/PULL) [8]	Mux Mode AFTER Reset [9]	Pull Type [10]	Power [11]	Hys [12]	Voltage Buffer Type [13]	IO RET [14]
T28	MCASP1_AXR0 PADCFG: PADCONFIG_48 0x0011C0C0	MCAN11_RX	0	I	1.8 V/3.3 V	Off / Off / Off	Off / Off / Off	7	PU/PD	VDDSHV2	Yes	LVCMOS	Yes
		MCASP1_AXR0	1	IO									
		GPMC0_A13	5	OZ									
		MDIO0_MDC	6	O									
		GPIO0_48	7	IO									
		SPI3_CLK	8	IO									
		EQEP1_S	9	IO									
		UART0_TXD	11	O									
		GPMC0_WAIT3	12	I									
		SYNC2_OUT	14	O									
V27	MCASP1_AXR1 PADCFG: PADCONFIG_19 0x0011C04C	MCAN7_RX	0	I	1.8 V/3.3 V	Off / Off / Off	Off / Off / Off	7	PU/PD	VDDSHV2	Yes	LVCMOS	Yes
		MCASP1_AXR1	1	IO									
		VOUT0_DATA10	2	O									
		HYP1_RXPMCLK	3	I									
		GPMC0_AD8	6	IO									
		GPIO0_19	7	IO									
		SPI3_D0	8	IO									
		EHRPWM_TZn_IN1	9	I									
		TRC_DATA8	10	O									
		UART0_CTSn	11	I									
		UART9_RXD	12	I									
		I2C2_SCL	13	IOD									
		W27	MCASP1_AXR2 PADCFG: PADCONFIG_20 0x0011C050	MCAN8_TX									
MCASP1_AXR2	1			IO									
VOUT0_DATA9	2			O									
HYP1_RXPMDAT	3			I									
VOUT0_DATA21	5			O									
GPMC0_AD9	6			IO									
GPIO0_20	7			IO									
SPI3_D1	8			IO									
EQEP2_B	9			I									
TRC_DATA6	10			O									
UART0_RTSn	11			O									
UART9_TXD	12			O									
I2C2_SDA	13			IOD									

表 6-1. Pin Attributes (ALZ Package) (continued)

Ball Num [1]	Ball Name [2] PADCFG Register [15] PADCFG Address [16]	Signal Name [3]	Mux Mode [4]	Signal Type [5]	I/O Voltage [6]	Ball State DURING Reset (RX/TX/PULL) [7]	Ball State AFTER Reset (RX/TX/PULL) [8]	Mux Mode AFTER Reset [9]	Pull Type [10]	Power [11]	Hys [12]	Voltage Buffer Type [13]	IO RET [14]
AD26	MCASP1_AXR3 PADCFG: PADCONFIG_44 0x0011C0B0	MCAN9_RX	0	I	1.8 V/3.3 V	Off / Off / Off	Off / Off / Off	7	PU/PD	VDDSHV2	Yes	LVCMOS	Yes
		MCASP1_AXR3	1	IO									
		GPMC0_A9	5	OZ									
		RGMI1_RXC	6	I									
		GPIO0_44	7	IO									
		RMII1_TXD1	8	O									
		EQEP1_A	9	I									
		UART8_TXD	11	O									
I2C1_SDA	13	IOD											
U25	MCASP1_AXR4 PADCFG: PADCONFIG_45 0x0011C0B4	MCAN10_TX	0	O	1.8 V/3.3 V	Off / Off / Off	Off / Off / Off	7	PU/PD	VDDSHV2	Yes	LVCMOS	Yes
		MCASP1_AXR4	1	IO									
		GPMC0_A10	5	OZ									
		RGMI1_TXC	6	O									
		GPIO0_45	7	IO									
		EQEP1_B	9	I									
		UART4_RXD	11	I									
AA26	MCASP2_AXR0 PADCFG: PADCONFIG_23 0x0011C05C	MCAN9_RX	0	I	1.8 V/3.3 V	Off / Off / Off	Off / Off / Off	7	PU/PD	VDDSHV2	Yes	LVCMOS	Yes
		MCASP2_AXR0	1	IO									
		VOUT0_DATA6	2	O									
		HYP0_RXPMCLK	3	I									
		GPMC0_AD12	6	IO									
		GPIO0_23	7	IO									
		EQEP2_I	9	IO									
		TRC_DATA15	10	O									
		UART1_CTSn	11	I									
		UART6_RXD	12	I									

表 6-1. Pin Attributes (ALZ Package) (continued)

Ball Num [1]	Ball Name [2] PADCFG Register [15] PADCFG Address [16]	Signal Name [3]	Mux Mode [4]	Signal Type [5]	I/O Voltage [6]	Ball State DURING Reset (RX/TX/PULL) [7]	Ball State AFTER Reset (RX/TX/PULL) [8]	Mux Mode AFTER Reset [9]	Pull Type [10]	Power [11]	Hys [12]	Voltage Buffer Type [13]	IO RET [14]
AC27	MCASP2_AXR1 PADCFG: PADCONFIG_24 0x0011C060	MCAN17_RX	0	I	1.8 V/3.3 V	Off / Off / Off	Off / Off / Off	7	PU/PD	VDDSHV2	Yes	LVC MOS	Yes
		MCASP2_AXR1	1	IO									
		VOOUT0_DATA5	2	O									
		HYP0_RXPMDAT	3	I									
		GPMC0_AD13	6	IO									
		GPIO0_24	7	IO									
		EHRPWM1_A	9	IO									
		TRC_DATA13	10	O									
		UART1_RTSn	11	O									
		UART6_TXD	12	O									
I2C3_SDA	13	IOD											
L25	MCU_ADC0_AIN0 PADCFG: WKUP_PADCONFIG_77 0x4301C134	MCU_ADC0_AIN0	0	A	1.8 V			0		VDDA_ADC0		ADC12B	No
		WKUP_GPIO0_71	7	I									
K25	MCU_ADC0_AIN1 PADCFG: WKUP_PADCONFIG_78 0x4301C138	MCU_ADC0_AIN1	0	A	1.8 V			0		VDDA_ADC0		ADC12B	No
		WKUP_GPIO0_72	7	I									
M24	MCU_ADC0_AIN2 PADCFG: WKUP_PADCONFIG_79 0x4301C13C	MCU_ADC0_AIN2	0	A	1.8 V			0		VDDA_ADC0		ADC12B	No
		WKUP_GPIO0_73	7	I									
L24	MCU_ADC0_AIN3 PADCFG: WKUP_PADCONFIG_80 0x4301C140	MCU_ADC0_AIN3	0	A	1.8 V			0		VDDA_ADC0		ADC12B	No
		WKUP_GPIO0_74	7	I									
L27	MCU_ADC0_AIN4 PADCFG: WKUP_PADCONFIG_81 0x4301C144	MCU_ADC0_AIN4	0	A	1.8 V			0		VDDA_ADC0		ADC12B	No
		WKUP_GPIO0_75	7	I									
K24	MCU_ADC0_AIN5 PADCFG: WKUP_PADCONFIG_82 0x4301C148	MCU_ADC0_AIN5	0	A	1.8 V			0		VDDA_ADC0		ADC12B	No
		WKUP_GPIO0_76	7	I									
M27	MCU_ADC0_AIN6 PADCFG: WKUP_PADCONFIG_83 0x4301C14C	MCU_ADC0_AIN6	0	A	1.8 V			0		VDDA_ADC0		ADC12B	No
		WKUP_GPIO0_77	7	I									
M26	MCU_ADC0_AIN7 PADCFG: WKUP_PADCONFIG_84 0x4301C150	MCU_ADC0_AIN7	0	A	1.8 V			0		VDDA_ADC0		ADC12B	No
		WKUP_GPIO0_78	7	I									

表 6-1. Pin Attributes (ALZ Package) (continued)

Ball Num [1]	Ball Name [2] PADCFG Register [15] PADCFG Address [16]	Signal Name [3]	Mux Mode [4]	Signal Type [5]	I/O Voltage [6]	Ball State DURING Reset (RX/TX/PULL) [7]	Ball State AFTER Reset (RX/TX/PULL) [8]	Mux Mode AFTER Reset [9]	Pull Type [10]	Power [11]	Hys [12]	Voltage Buffer Type [13]	IO RET [14]
P25	MCU_ADC1_AIN0 PADCFG: WKUP_PADCONFIG_85 0x4301C154	MCU_ADC1_AIN0	0	A	1.8 V			0		VDDA_ADC1		ADC12B	No
		WKUP_GPIO0_79	7	I									
R25	MCU_ADC1_AIN1 PADCFG: WKUP_PADCONFIG_86 0x4301C158	MCU_ADC1_AIN1	0	A	1.8 V			0		VDDA_ADC1		ADC12B	No
		WKUP_GPIO0_80	7	I									
P28	MCU_ADC1_AIN2 PADCFG: WKUP_PADCONFIG_87 0x4301C15C	MCU_ADC1_AIN2	0	A	1.8 V			0		VDDA_ADC1		ADC12B	No
		WKUP_GPIO0_81	7	I									
P27	MCU_ADC1_AIN3 PADCFG: WKUP_PADCONFIG_88 0x4301C160	MCU_ADC1_AIN3	0	A	1.8 V			0		VDDA_ADC1		ADC12B	No
		WKUP_GPIO0_82	7	I									
N25	MCU_ADC1_AIN4 PADCFG: WKUP_PADCONFIG_89 0x4301C164	MCU_ADC1_AIN4	0	A	1.8 V			0		VDDA_ADC1		ADC12B	No
		WKUP_GPIO0_83	7	I									
P26	MCU_ADC1_AIN5 PADCFG: WKUP_PADCONFIG_90 0x4301C168	MCU_ADC1_AIN5	0	A	1.8 V			0		VDDA_ADC1		ADC12B	No
		WKUP_GPIO0_84	7	I									
N26	MCU_ADC1_AIN6 PADCFG: WKUP_PADCONFIG_91 0x4301C16C	MCU_ADC1_AIN6	0	A	1.8 V			0		VDDA_ADC1		ADC12B	No
		WKUP_GPIO0_85	7	I									
N27	MCU_ADC1_AIN7 PADCFG: WKUP_PADCONFIG_92 0x4301C170	MCU_ADC1_AIN7	0	A	1.8 V			0		VDDA_ADC1		ADC12B	No
		WKUP_GPIO0_86	7	I									
G24	MCU_I2C0_SCL PADCFG: WKUP_PADCONFIG_66 0x4301C108	MCU_I2C0_SCL	0	IOD	1.8 V/3.3 V	Off / Off / Off	On / SS / Off	0		VDDSHV0_M CU	Yes	I2C OPEN DRAIN	Yes
		WKUP_GPIO0_65	7	IO									
J25	MCU_I2C0_SDA PADCFG: WKUP_PADCONFIG_67 0x4301C10C	MCU_I2C0_SDA	0	IOD	1.8 V/3.3 V	Off / Off / Off	On / SS / Off	0		VDDSHV0_M CU	Yes	I2C OPEN DRAIN	Yes
		WKUP_GPIO0_87	7	IO									
E28	MCU_MCAN0_RX PADCFG: WKUP_PADCONFIG_47 0x4301C0BC	MCU_MCAN0_RX	0	I	1.8 V/3.3 V	Off / Off / Off	Off / Off / Off	7	PU/PD	VDDSHV0_M CU	Yes	LVCMOS	Yes
		WKUP_GPIO0_61	7	IO									

表 6-1. Pin Attributes (ALZ Package) (continued)

Ball Num [1]	Ball Name [2] PADCFG Register [15] PADCFG Address [16]	Signal Name [3]	Mux Mode [4]	Signal Type [5]	I/O Voltage [6]	Ball State DURING Reset (RX/TX/PULL) [7]	Ball State AFTER Reset (RX/TX/PULL) [8]	Mux Mode AFTER Reset [9]	Pull Type [10]	Power [11]	Hys [12]	Voltage Buffer Type [13]	IO RET [14]
E27	MCU_MCAN0_TX PADCFG: WKUP_PADCONFIG_46 0x4301C0B8	MCU_MCAN0_TX	0	O	1.8 V/3.3 V	Off / Off / Off	Off / Off / Off	7	PU/PD	VDDSHV0_MCU	Yes	LVCMOS	Yes
		WKUP_GPIO0_60	7	IO									
A21	MCU_MDIO0_MDC PADCFG: WKUP_PADCONFIG_39 0x4301C09C	MCU_MDIO0_MDC	0	O	1.8 V/3.3 V	Off / Off / Off	Off / Off / Off	7	PU/PD	VDDSHV2_MCU	Yes	LVCMOS	No
		WKUP_GPIO0_53	7	IO									
A22	MCU_MDIO0_MDIO PADCFG: WKUP_PADCONFIG_38 0x4301C098	MCU_MDIO0_MDIO	0	IO	1.8 V/3.3 V	Off / Off / Off	Off / Off / Off	7	PU/PD	VDDSHV2_MCU	Yes	LVCMOS	No
		WKUP_GPIO0_52	7	IO									
D19	MCU_OSPI0_CLK PADCFG: WKUP_PADCONFIG_0 0x4301C000	MCU_OSPI0_CLK	0	O	1.8 V/3.3 V	Off / Off / Off	Off / Off / Off	7	PU/PD	VDDSHV1_MCU	Yes	LVCMOS	No
		MCU_HYPERBUS0_CK	1	O									
		WKUP_GPIO0_16	7	IO									
E18	MCU_OSPI0_DQS PADCFG: WKUP_PADCONFIG_2 0x4301C008	MCU_OSPI0_DQS	0	I	1.8 V/3.3 V	Off / Off / Off	Off / Off / Off	7	PU/PD	VDDSHV1_MCU	Yes	LVCMOS	No
		MCU_HYPERBUS0_RWDS	1	IO									
		WKUP_GPIO0_18	7	IO									
E20	MCU_OSPI0_LBCLKO PADCFG: WKUP_PADCONFIG_1 0x4301C004	MCU_OSPI0_LBCLKO	0	IO	1.8 V/3.3 V	Off / Off / Off	On / Off / Off	7	PU/PD	VDDSHV1_MCU	Yes	LVCMOS	No
		MCU_HYPERBUS0_CK <sub>n</sub>	1	O									
		WKUP_GPIO0_17	7	IO									
A19	MCU_OSPI1_CLK PADCFG: WKUP_PADCONFIG_16 0x4301C040	MCU_OSPI1_CLK	0	O	1.8 V/3.3 V	Off / Off / Off	Off / Off / Off	7	PU/PD	VDDSHV1_MCU	Yes	LVCMOS	No
		WKUP_GPIO0_31	7	IO									
B19	MCU_OSPI1_DQS PADCFG: WKUP_PADCONFIG_18 0x4301C048	MCU_OSPI1_DQS	0	I	1.8 V/3.3 V	Off / Off / Off	Off / Off / Off	7	PU/PD	VDDSHV1_MCU	Yes	LVCMOS	No
		MCU_OSPI0_CS <sub>n3</sub>	1	O									
		MCU_HYPERBUS0_INT <sub>n</sub>	2	I									
		MCU_OSPI0_ECC_FAIL	6	I									
B20	MCU_OSPI1_LBCLKO PADCFG: WKUP_PADCONFIG_17 0x4301C044	WKUP_GPIO0_33	7	IO	1.8 V/3.3 V	Off / Off / Off	On / Off / Off	7	PU/PD	VDDSHV1_MCU	Yes	LVCMOS	No
		MCU_OSPI1_LBCLKO	0	IO									
		MCU_OSPI0_CS <sub>n2</sub>	1	O									
		MCU_HYPERBUS0_RESE <sub>T</sub> <sub>On</sub>	2	I									
		MCU_OSPI0_RESE <sub>T</sub> _OUT <sub>0</sub>	6	O									
F15	MCU_OSPI0_CS <sub>n0</sub> PADCFG: WKUP_PADCONFIG_11 0x4301C02C	WKUP_GPIO0_32	7	IO	1.8 V/3.3 V	Off / Off / Off	Off / Off / Off	7	PU/PD	VDDSHV1_MCU	Yes	LVCMOS	No
		MCU_OSPI0_CS <sub>n0</sub>	0	O									
		MCU_HYPERBUS0_CS <sub>n0</sub>	1	O									
		WKUP_GPIO0_27	7	IO									

表 6-1. Pin Attributes (ALZ Package) (continued)

Ball Num [1]	Ball Name [2] PADCFG Register [15] PADCFG Address [16]	Signal Name [3]	Mux Mode [4]	Signal Type [5]	I/O Voltage [6]	Ball State DURING Reset (RX/TX/PULL) [7]	Ball State AFTER Reset (RX/TX/PULL) [8]	Mux Mode AFTER Reset [9]	Pull Type [10]	Power [11]	Hys [12]	Voltage Buffer Type [13]	IO RET [14]
G17	MCU_OSPI0_CSn1 PADCFG: WKUP_PADCONFIG_12 0x4301C030	MCU_OSPI0_CSn1	0	O	1.8 V/3.3 V	Off / Off / Off	Off / Off / Off	7	PU/PD	VDDSHV1_MCU	Yes	LVCMOS	No
		MCU_HYPERBUS0_RESETEn	1	O									
		WKUP_GPIO0_28	7	IO									
F14	MCU_OSPI0_CSn2 PADCFG: WKUP_PADCONFIG_14 0x4301C038	MCU_OSPI0_CSn2	0	O	1.8 V/3.3 V	Off / Off / Off	Off / Off / Off	7	PU/PD	VDDSHV1_MCU	Yes	LVCMOS	No
		MCU_HYPERBUS0_RESETEn	1	O									
		MCU_HYPERBUS0_WPn	2	I									
		MCU_HYPERBUS0_CSn1	3	O									
		MCU_OSPI0_RESET_OUT0	4	O									
		WKUP_GPIO0_29	6	O									
F17	MCU_OSPI0_CSn3 PADCFG: WKUP_PADCONFIG_15 0x4301C03C	MCU_OSPI0_CSn3	0	O	1.8 V/3.3 V	Off / Off / Off	Off / Off / Off	7	PU/PD	VDDSHV1_MCU	Yes	LVCMOS	No
		MCU_OSPI0_CSn3	1	O									
		MCU_HYPERBUS0_INTn	2	I									
		MCU_HYPERBUS0_WPn	3	O									
		MCU_OSPI0_RESET_OUT1	5	O									
		MCU_OSPI0_ECC_FAIL	6	I									
C19	MCU_OSPI0_D0 PADCFG: WKUP_PADCONFIG_3 0x4301C00C	MCU_OSPI0_D0	0	IO	1.8 V/3.3 V	On / Off / Off	On / Off / Off	7	PU/PD	VDDSHV1_MCU	Yes	LVCMOS	No
		MCU_HYPERBUS0_DQ0	1	IO									
		WKUP_GPIO0_19	7	IO									
		BOOTMODE00	BOOTS TRAP	I									
F16	MCU_OSPI0_D1 PADCFG: WKUP_PADCONFIG_4 0x4301C010	MCU_OSPI0_D1	0	IO	1.8 V/3.3 V	On / Off / Off	On / Off / Off	7	PU/PD	VDDSHV1_MCU	Yes	LVCMOS	No
		MCU_HYPERBUS0_DQ1	1	IO									
		WKUP_GPIO0_20	7	IO									
		BOOTMODE01	BOOTS TRAP	I									
G15	MCU_OSPI0_D2 PADCFG: WKUP_PADCONFIG_5 0x4301C014	MCU_OSPI0_D2	0	IO	1.8 V/3.3 V	Off / Off / Off	Off / Off / Off	7	PU/PD	VDDSHV1_MCU	Yes	LVCMOS	No
		MCU_HYPERBUS0_DQ2	1	IO									
		WKUP_GPIO0_21	7	IO									
F18	MCU_OSPI0_D3 PADCFG: WKUP_PADCONFIG_6 0x4301C018	MCU_OSPI0_D3	0	IO	1.8 V/3.3 V	Off / Off / Off	Off / Off / Off	7	PU/PD	VDDSHV1_MCU	Yes	LVCMOS	No
		MCU_HYPERBUS0_DQ3	1	IO									
		WKUP_GPIO0_22	7	IO									

表 6-1. Pin Attributes (ALZ Package) (continued)

Ball Num [1]	Ball Name [2] PADCFG Register [15] PADCFG Address [16]	Signal Name [3]	Mux Mode [4]	Signal Type [5]	I/O Voltage [6]	Ball State DURING Reset (RX/TX/PULL) [7]	Ball State AFTER Reset (RX/TX/PULL) [8]	Mux Mode AFTER Reset [9]	Pull Type [10]	Power [11]	Hys [12]	Voltage Buffer Type [13]	IO RET [14]
E19	MCU_OSPI0_D4 PADCFG: WKUP_PADCONFIG_7 0x4301C01C	MCU_OSPI0_D4	0	IO	1.8 V/3.3 V	On / Off / Off	On / Off / Off	7	PU/PD	VDDSHV1_MCU	Yes	LVCMOS	No
		MCU_HYPERBUS0_DQ4	1	IO									
		WKUP_GPIO0_23	7	IO									
		BOOTMODE02	BOOTS TRAP	I									
G19	MCU_OSPI0_D5 PADCFG: WKUP_PADCONFIG_8 0x4301C020	MCU_OSPI0_D5	0	IO	1.8 V/3.3 V	On / Off / Off	On / Off / Off	7	PU/PD	VDDSHV1_MCU	Yes	LVCMOS	No
		MCU_HYPERBUS0_DQ5	1	IO									
		WKUP_GPIO0_24	7	IO									
		BOOTMODE03	BOOTS TRAP	I									
F19	MCU_OSPI0_D6 PADCFG: WKUP_PADCONFIG_9 0x4301C024	MCU_OSPI0_D6	0	IO	1.8 V/3.3 V	Off / Off / Off	Off / Off / Off	7	PU/PD	VDDSHV1_MCU	Yes	LVCMOS	No
		MCU_HYPERBUS0_DQ6	1	IO									
		WKUP_GPIO0_25	7	IO									
F20	MCU_OSPI0_D7 PADCFG: WKUP_PADCONFIG_10 0x4301C028	MCU_OSPI0_D7	0	IO	1.8 V/3.3 V	Off / Off / Off	Off / Off / Off	7	PU/PD	VDDSHV1_MCU	Yes	LVCMOS	No
		MCU_HYPERBUS0_DQ7	1	IO									
		WKUP_GPIO0_26	7	IO									
D20	MCU_OSPI1_CSn0 PADCFG: WKUP_PADCONFIG_23 0x4301C05C	MCU_OSPI1_CSn0	0	O	1.8 V/3.3 V	Off / Off / Off	Off / Off / Off	7	PU/PD	VDDSHV1_MCU	Yes	LVCMOS	No
		WKUP_GPIO0_38	7	IO									
C21	MCU_OSPI1_CSn1 PADCFG: WKUP_PADCONFIG_24 0x4301C060	MCU_OSPI1_CSn1	0	O	1.8 V/3.3 V	Off / Off / Off	Off / Off / Off	7	PU/PD	VDDSHV1_MCU	Yes	LVCMOS	No
		MCU_HYPERBUS0_WPn	1	O									
		MCU_TIMER_IO0	2	IO									
		MCU_HYPERBUS0_CSn1	3	O									
		MCU_UART0_RTSn	4	O									
		MCU_SPI0_CS2	5	IO									
		MCU_OSPI0_RESET_OUT1	6	O									
WKUP_GPIO0_39	7	IO											
D21	MCU_OSPI1_D0 PADCFG: WKUP_PADCONFIG_19 0x4301C04C	MCU_OSPI1_D0	0	IO	1.8 V/3.3 V	Off / Off / Off	Off / Off / Off	7	PU/PD	VDDSHV1_MCU	Yes	LVCMOS	No
		WKUP_GPIO0_34	7	IO									
G20	MCU_OSPI1_D1 PADCFG: WKUP_PADCONFIG_20 0x4301C050	MCU_OSPI1_D1	0	IO	1.8 V/3.3 V	Off / Off / Off	Off / Off / Off	7	PU/PD	VDDSHV1_MCU	Yes	LVCMOS	No
		MCU_UART0_RXD	4	I									
		MCU_SPI1_CS1	5	IO									
		WKUP_GPIO0_35	7	IO									

表 6-1. Pin Attributes (ALZ Package) (continued)

Ball Num [1]	Ball Name [2] PADCFG Register [15] PADCFG Address [16]	Signal Name [3]	Mux Mode [4]	Signal Type [5]	I/O Voltage [6]	Ball State DURING Reset (RX/TX/PULL) [7]	Ball State AFTER Reset (RX/TX/PULL) [8]	Mux Mode AFTER Reset [9]	Pull Type [10]	Power [11]	Hys [12]	Voltage Buffer Type [13]	IO RET [14]
C20	MCU_OSP11_D2 PADCFG: WKUP_PADCONFIG_21 0x4301C054	MCU_OSP11_D2	0	IO	1.8 V/3.3 V	Off / Off / Off	Off / Off / Off	7	PU/PD	VDDSHV1_M CU	Yes	LVCMOS	No
		MCU_UART0_TXD	4	O									
		MCU_SPI1_CS2	5	IO									
		WKUP_GPIO0_36	7	IO									
A20	MCU_OSP11_D3 PADCFG: WKUP_PADCONFIG_22 0x4301C058	MCU_OSP11_D3	0	IO	1.8 V/3.3 V	Off / Off / Off	Off / Off / Off	7	PU/PD	VDDSHV1_M CU	Yes	LVCMOS	No
		MCU_UART0_CTSn	4	I									
		MCU_SPI0_CS1	5	IO									
		WKUP_GPIO0_37	7	IO									
G23	MCU_PORz	MCU_PORz		I	1.8 V					VDDA_WKUP	Yes	FS_RESET	No
A23	MCU_RESETSTATz PADCFG: WKUP_PADCONFIG_71 0x4301C11C	MCU_RESETSTATz	0	O	1.8 V/3.3 V	Off / Low / Off	Off / SS / Off	0	PU/PD	VDDSHV0_M CU	Yes	LVCMOS	No
		WKUP_GPIO0_68	7	IO									
A26	MCU_RESETz PADCFG: WKUP_PADCONFIG_70 0x4301C118	MCU_RESETz	0	I	1.8 V/3.3 V	On / NA / Up	On / Off / Up	0	PU/PD	VDDSHV0_M CU	Yes	LVCMOS	No
D22	MCU_RGMII1_RXC PADCFG: WKUP_PADCONFIG_33 0x4301C084	MCU_RGMII1_RXC	0	I	1.8 V/3.3 V	Off / Off / Off	Off / Off / Off	7	PU/PD	VDDSHV2_M CU	Yes	LVCMOS	No
		MCU_RMII1_REF_CLK	1	I									
		WKUP_GPIO0_47	7	IO									
E23	MCU_RGMII1_RX_CTL PADCFG: WKUP_PADCONFIG_27 0x4301C06C	MCU_RGMII1_RX_CTL	0	I	1.8 V/3.3 V	Off / Off / Off	Off / Off / Off	7	PU/PD	VDDSHV2_M CU	Yes	LVCMOS	No
		MCU_RMII1_RX_ER	1	I									
		WKUP_GPIO0_41	7	IO									
F21	MCU_RGMII1_TXC PADCFG: WKUP_PADCONFIG_32 0x4301C080	MCU_RGMII1_TXC	0	O	1.8 V/3.3 V	Off / Off / Off	Off / Off / Off	7	PU/PD	VDDSHV2_M CU	Yes	LVCMOS	No
		MCU_RMII1_TX_EN	1	O									
		WKUP_GPIO0_46	7	IO									
F22	MCU_RGMII1_TX_CTL PADCFG: WKUP_PADCONFIG_26 0x4301C068	MCU_RGMII1_TX_CTL	0	O	1.8 V/3.3 V	Off / Off / Off	Off / Off / Off	7	PU/PD	VDDSHV2_M CU	Yes	LVCMOS	No
		MCU_RMII1_CRS_DV	1	I									
		WKUP_GPIO0_40	7	IO									
B22	MCU_RGMII1_RD0 PADCFG: WKUP_PADCONFIG_37 0x4301C094	MCU_RGMII1_RD0	0	I	1.8 V/3.3 V	Off / Off / Off	Off / Off / Off	7	PU/PD	VDDSHV2_M CU	Yes	LVCMOS	No
		MCU_RMII1_RXD0	1	I									
		WKUP_GPIO0_51	7	IO									
B21	MCU_RGMII1_RD1 PADCFG: WKUP_PADCONFIG_36 0x4301C090	MCU_RGMII1_RD1	0	I	1.8 V/3.3 V	Off / Off / Off	Off / Off / Off	7	PU/PD	VDDSHV2_M CU	Yes	LVCMOS	No
		MCU_RMII1_RXD1	1	I									
		WKUP_GPIO0_50	7	IO									

表 6-1. Pin Attributes (ALZ Package) (continued)

Ball Num [1]	Ball Name [2] PADCFG Register [15] PADCFG Address [16]	Signal Name [3]	Mux Mode [4]	Signal Type [5]	I/O Voltage [6]	Ball State DURING Reset (RX/TX/PULL) [7]	Ball State AFTER Reset (RX/TX/PULL) [8]	Mux Mode AFTER Reset [9]	Pull Type [10]	Power [11]	Hys [12]	Voltage Buffer Type [13]	IO RET [14]
C22	MCU_RGMII1_RD2 PADCFG: WKUP_PADCONFIG_35 0x4301C08C	MCU_RGMII1_RD2	0	I	1.8 V/3.3 V	Off / Off / Off	Off / Off / Off	7	PU/PD	VDDSHV2_MCU	Yes	LVCMOS	No
		MCU_TIMER_IO5	1	IO									
		WKUP_GPIO0_62	7	IO									
D23	MCU_RGMII1_RD3 PADCFG: WKUP_PADCONFIG_34 0x4301C088	MCU_RGMII1_RD3	0	I	1.8 V/3.3 V	Off / Off / Off	Off / Off / Off	7	PU/PD	VDDSHV2_MCU	Yes	LVCMOS	No
		MCU_TIMER_IO4	1	IO									
		WKUP_GPIO0_48	7	IO									
F23	MCU_RGMII1_TD0 PADCFG: WKUP_PADCONFIG_31 0x4301C07C	MCU_RGMII1_TD0	0	O	1.8 V/3.3 V	Off / Off / Off	Off / Off / Off	7	PU/PD	VDDSHV2_MCU	Yes	LVCMOS	No
		MCU_RMII1_TXD0	1	O									
		WKUP_GPIO0_45	7	IO									
G22	MCU_RGMII1_TD1 PADCFG: WKUP_PADCONFIG_30 0x4301C078	MCU_RGMII1_TD1	0	O	1.8 V/3.3 V	Off / Off / Off	Off / Off / Off	7	PU/PD	VDDSHV2_MCU	Yes	LVCMOS	No
		MCU_RMII1_TXD1	1	O									
		WKUP_GPIO0_44	7	IO									
E21	MCU_RGMII1_TD2 PADCFG: WKUP_PADCONFIG_29 0x4301C074	MCU_RGMII1_TD2	0	O	1.8 V/3.3 V	Off / Off / Off	Off / Off / Off	7	PU/PD	VDDSHV2_MCU	Yes	LVCMOS	No
		MCU_TIMER_IO3	1	IO									
		MCU_ADC_EXT_TRIGGER1	3	I									
		WKUP_GPIO0_43	7	IO									
E22	MCU_RGMII1_TD3 PADCFG: WKUP_PADCONFIG_28 0x4301C070	MCU_RGMII1_TD3	0	O	1.8 V/3.3 V	Off / Off / Off	Off / Off / Off	7	PU/PD	VDDSHV2_MCU	Yes	LVCMOS	No
		MCU_TIMER_IO2	1	IO									
		MCU_ADC_EXT_TRIGGER0	3	I									
		WKUP_GPIO0_42	7	IO									
J23	MCU_SAFETY_ERRORn PADCFG: WKUP_PADCONFIG_69 0x4301C114	MCU_SAFETY_ERRORn	0	IO	1.8 V	Off / Off / Down	On / SS / Down	0	PU/PD	VDDA_WKUP	Yes	LVCMOS	No
B27	MCU_SPI0_CLK PADCFG: WKUP_PADCONFIG_40 0x4301C0A0	MCU_SPI0_CLK	0	IO	1.8 V/3.3 V	On / Off / Off	On / Off / Off	7	PU/PD	VDDSHV0_MCU	Yes	LVCMOS	Yes
		WKUP_GPIO0_54	7	IO									
		MCU_BOOTMODE00	BOOTS TRAP	I									
B26	MCU_SPI0_CS0 PADCFG: WKUP_PADCONFIG_43 0x4301C0AC	MCU_SPI0_CS0	0	IO	1.8 V/3.3 V	Off / Off / Off	Off / Off / Off	7	PU/PD	VDDSHV0_MCU	Yes	LVCMOS	Yes
		MCU_TIMER_IO1	4	IO									
		WKUP_GPIO0_70	7	IO									
D24	MCU_SPI0_D0 PADCFG: WKUP_PADCONFIG_41 0x4301C0A4	MCU_SPI0_D0	0	IO	1.8 V/3.3 V	On / Off / Off	On / Off / Off	7	PU/PD	VDDSHV0_MCU	Yes	LVCMOS	Yes
		WKUP_GPIO0_55	7	IO									
		MCU_BOOTMODE01	BOOTS TRAP	I									

**表 6-1. Pin Attributes (ALZ Package) (continued)**

Ball Num [1]	Ball Name [2] PADCFG Register [15] PADCFG Address [16]	Signal Name [3]	Mux Mode [4]	Signal Type [5]	I/O Voltage [6]	Ball State DURING Reset (RX/TX/PULL) [7]	Ball State AFTER Reset (RX/TX/PULL) [8]	Mux Mode AFTER Reset [9]	Pull Type [10]	Power [11]	Hys [12]	Voltage Buffer Type [13]	IO RET [14]
B25	MCU_SPI0_D1 PADCFG: WKUP_PADCONFIG_42 0x4301C0A8	MCU_SPI0_D1	0	IO	1.8 V/3.3 V	On / Off / Off	On / Off / Off	7	PU/PD	VDDSHV0_MCU	Yes	LVC MOS	Yes
		MCU_TIMER_IO0	4	IO									
		WKUP_GPIO0_69	7	IO									
		MCU_BOOTMODE02	BOOTS TRAP	I									
AF1	MMC0_CALPAD	MMC0_CALPAD		A	1.8 V				PU/PD	VDDS_MMC0		eMMC PHY	No
AC6	MMC0_CLK	MMC0_CLK		O	1.8 V				PU/PD	VDDS_MMC0		eMMC PHY	No
AF2	MMC0_CMD	MMC0_CMD		IO	1.8 V				PU/PD	VDDS_MMC0		eMMC PHY	No
AE3	MMC0_DS	MMC0_DS		IO	1.8 V				PU/PD	VDDS_MMC0		eMMC PHY	No
P23	MMC1_CLK PADCFG: PADCONFIG_65 0x0011C104	MMC1_CLK	0	IO	1.8 V/3.3 V	Off / Off / Off	Off / Off / Off	7	PU/PD	VDDSHV5	Yes	SDIO	No
		UART8_RXD	1	I									
		TIMER_IO6	3	IO									
		EHRPWM2_B	4	IO									
		UART4_CTSn	5	I									
		EHRPWM5_A	6	IO									
		GPIO0_64	7	IO									
		SPI1_CLK	8	IO									
		UART0_RTSn	9	O									
		I2C6_SDA	10	IOD									
MCAN15_TX	11	O											
N24	MMC1_CMD PADCFG: PADCONFIG_66 0x0011C108	MMC1_CMD	0	IO	1.8 V/3.3 V	Off / Off / Off	Off / Off / Off	7	PU/PD	VDDSHV5	Yes	SDIO	No
		UART8_TXD	1	O									
		TIMER_IO7	3	IO									
		EHRPWM2_A	4	IO									
		UART4_RTSn	5	O									
		GPIO0_65	7	IO									
		SPI1_D1	8	IO									
		I2C6_SCL	10	IOD									
MCAN15_RX	11	I											
AF4	MMC0_DAT0	MMC0_DAT0		IO	1.8 V				PU/PD	VDDS_MMC0		eMMC PHY	No
AD3	MMC0_DAT1	MMC0_DAT1		IO	1.8 V				PU/PD	VDDS_MMC0		eMMC PHY	No
AD4	MMC0_DAT2	MMC0_DAT2		IO	1.8 V				PU/PD	VDDS_MMC0		eMMC PHY	No
AF3	MMC0_DAT3	MMC0_DAT3		IO	1.8 V				PU/PD	VDDS_MMC0		eMMC PHY	No
AE2	MMC0_DAT4	MMC0_DAT4		IO	1.8 V				PU/PD	VDDS_MMC0		eMMC PHY	No
AG3	MMC0_DAT5	MMC0_DAT5		IO	1.8 V				PU/PD	VDDS_MMC0		eMMC PHY	No
AE1	MMC0_DAT6	MMC0_DAT6		IO	1.8 V				PU/PD	VDDS_MMC0		eMMC PHY	No
AG1	MMC0_DAT7	MMC0_DAT7		IO	1.8 V				PU/PD	VDDS_MMC0		eMMC PHY	No

表 6-1. Pin Attributes (ALZ Package) (continued)

Ball Num [1]	Ball Name [2] PADCFG Register [15] PADCFG Address [16]	Signal Name [3]	Mux Mode [4]	Signal Type [5]	I/O Voltage [6]	Ball State DURING Reset (RX/TX/PULL) [7]	Ball State AFTER Reset (RX/TX/PULL) [8]	Mux Mode AFTER Reset [9]	Pull Type [10]	Power [11]	Hys [12]	Voltage Buffer Type [13]	IO RET [14]
M23	MMC1_DAT0 PADCFG: PADCONFIG_63 0x0011C0FC	MMC1_DAT0	0	IO	1.8 V/3.3 V	Off / Off / Off	Off / Off / Off	7	PU/PD	VDDSHV5	Yes	SDIO	No
		UART7_RTSn	1	O									
		ECAP1_IN_APWM_OUT	2	IO									
		TIMER_IO5	3	IO									
		EHRPWM1_A	4	IO									
		UART4_TXD	5	O									
		GPIO0_63	7	IO									
		SPI1_D0	8	IO									
		UART5_RTSn	9	O									
		I2C4_SCL	10	IOD									
		UART2_TXD	11	O									
P24	MMC1_DAT1 PADCFG: PADCONFIG_62 0x0011C0F8	MMC1_DAT1	0	IO	1.8 V/3.3 V	Off / Off / Off	Off / Off / Off	7	PU/PD	VDDSHV5	Yes	SDIO	No
		UART7_CTSn	1	I									
		ECAP0_IN_APWM_OUT	2	IO									
		TIMER_IO4	3	IO									
		EHRPWM1_B	4	IO									
		UART4_RXD	5	I									
		EHRPWM4_A	6	IO									
		GPIO0_62	7	IO									
		SPI1_CS2	8	IO									
		UART5_CTSn	9	I									
		I2C4_SDA	10	IOD									
UART2_RXD	11	I											
R24	MMC1_DAT2 PADCFG: PADCONFIG_61 0x0011C0F4	MMC1_DAT2	0	IO	1.8 V/3.3 V	Off / Off / Off	Off / Off / Off	7	PU/PD	VDDSHV5	Yes	SDIO	No
		UART7_TXD	1	O									
		TIMER_IO3	3	IO									
		EHRPWM0_A	4	IO									
		GPIO0_61	7	IO									
		SPI1_CS1	8	IO									
		CPTS0_TS_SYNC	9	O									
		I2C3_SDA	10	IOD									
UART5_TXD	11	O											

**表 6-1. Pin Attributes (ALZ Package) (continued)**

Ball Num [1]	Ball Name [2] PADCFG Register [15] PADCFG Address [16]	Signal Name [3]	Mux Mode [4]	Signal Type [5]	I/O Voltage [6]	Ball State DURING Reset (RX/TX/PULL) [7]	Ball State AFTER Reset (RX/TX/PULL) [8]	Mux Mode AFTER Reset [9]	Pull Type [10]	Power [11]	Hys [12]	Voltage Buffer Type [13]	IO RET [14]
R22	MMC1_DAT3 PADCFG: PADCONFIG_60 0x0011C0F0	MMC1_DAT3	0	IO	1.8 V/3.3 V	Off / Off / Off	Off / Off / Off	7	PU/PD	VDDSHV5	Yes	SDIO	No
		UART7_RXD	1	I									
		PCIE1_CLKREQn	2	IO									
		TIMER_IO2	3	IO									
		EHRPWM0_B	4	IO									
		EHRPWM3_A	6	IO									
		GPIO0_60	7	IO									
		SPI1_CS0	8	IO									
		UART0_CTSn	9	I									
		I2C3_SCL	10	IOD									
		UART5_RXD	11	I									
M28	OSC1_XI	OSC1_XI		I	1.8 V					VDDA_OSC1	Yes	HFXOSC	
L28	OSC1_XO	OSC1_XO		O	1.8 V					VDDA_OSC1	Yes	HFXOSC	
AH10	PCIE_REFCLK1_N_OUT	PCIE_REFCLK1_N_OUT		O	1.8 V					VDDA_0P8_S ERDES0_1 / VDDA_0P8_S ERDES_C0_1 / VDDA_1P8_S ERDES0_1		4L_PHY	
AH11	PCIE_REFCLK1_P_OUT	PCIE_REFCLK1_P_OUT		O	1.8 V					VDDA_0P8_S ERDES0_1 / VDDA_0P8_S ERDES_C0_1 / VDDA_1P8_S ERDES0_1		4L_PHY	
G26	PMIC_POWER_EN1 PADCFG: WKUP_PADCONFIG_68 0x4301C110	PMIC_POWER_EN1	0	O	1.8 V/3.3 V	Off / Off / Off	Off / Off / Off	7	PU/PD	VDDSHV0_M CU	Yes	LVC MOS	Yes
		MCU_I3C0_SDAPULLEN	5	OD									
		WKUP_GPIO0_88	7	IO									
AD24	PMIC_WAKE0 PADCFG: PADCONFIG_13 0x0011C034	PMIC_WAKE0	0	OD	1.8 V/3.3 V	Off / Off / Off	Off / Off / Off	7	PU/PD	VDDSHV2	Yes	LVC MOS	No
		MCASP4_AXR0	1	IO									
		DSS_FSYNC1	4	O									
		MCAN17_RX	5	I									
		GPMC0_WEn	6	O									
		GPIO0_13	7	IO									
		SPI6_CS0	8	IO									
		TRC_DATA0	10	O									
		UART9_RTSn	11	O									
		UART7_TXD	13	O									
		AUDIO_EXT_REFCLK0	14	IO									

表 6-1. Pin Attributes (ALZ Package) (continued)

Ball Num [1]	Ball Name [2] PADCFG Register [15] PADCFG Address [16]	Signal Name [3]	Mux Mode [4]	Signal Type [5]	I/O Voltage [6]	Ball State DURING Reset (RX/TX/PULL) [7]	Ball State AFTER Reset (RX/TX/PULL) [8]	Mux Mode AFTER Reset [9]	Pull Type [10]	Power [11]	Hys [12]	Voltage Buffer Type [13]	IO RET [14]
K23	PORz PADCFG: WKUP_PADCONFIG_94 0x4301C178	PORz	0	I	1.8 V			0		VDDA_WKUP	Yes	FS_RESET	No
AF27	RESETSTATz PADCFG: PADCONFIG_67 0x0011C10C	RESETSTATz	0	O	1.8 V/3.3 V	Off / Low / Off	Off / SS / Off	0	PU/PD	VDDSHV0	Yes	LVC MOS	No
A24	RESET_REQz PADCFG: WKUP_PADCONFIG_93 0x4301C174	RESET_REQz	0	I	1.8 V/3.3 V	On / Off / Up	On / Off / Up	0	PU/PD	VDDSHV0_M CU	Yes	LVC MOS	No
AH4	SERDES0_REFCLK_N	SERDES0_REFCLK_N	0	IO	1.8 V					VDDA_0P8_S ERDES0_1 / VDDA_0P8_S ERDES_C0_1 / VDDA_1P8_S ERDES0_1		4L_PHY	
AH5	SERDES0_REFCLK_P	SERDES0_REFCLK_P	0	IO	1.8 V					VDDA_0P8_S ERDES0_1 / VDDA_0P8_S ERDES_C0_1 / VDDA_1P8_S ERDES0_1		4L_PHY	
AC10	SERDES0_REXT	SERDES0_REXT		I	1.8 V					VDDA_0P8_S ERDES0_1 / VDDA_0P8_S ERDES_C0_1 / VDDA_1P8_S ERDES0_1		4L_PHY	
AF9	SERDES0_RX0_N	PCIE1_RXN0	1	I	1.8 V					VDDA_0P8_S ERDES0_1 / VDDA_0P8_S ERDES_C0_1 / VDDA_1P8_S ERDES0_1		4L_PHY	
		USB0_SSRX1N	2	I									
		HYP_RXN0	4	I									
AF10	SERDES0_RX0_P	PCIE1_RXP0	1	I	1.8 V					VDDA_0P8_S ERDES0_1 / VDDA_0P8_S ERDES_C0_1 / VDDA_1P8_S ERDES0_1		4L_PHY	
		USB0_SSRX1P	2	I									
		HYP_RXP0	4	I									

表 6-1. Pin Attributes (ALZ Package) (continued)

Ball Num [1]	Ball Name [2] PADCFG Register [15] PADCFG Address [16]	Signal Name [3]	Mux Mode [4]	Signal Type [5]	I/O Voltage [6]	Ball State DURING Reset (RX/TX/PULL) [7]	Ball State AFTER Reset (RX/TX/PULL) [8]	Mux Mode AFTER Reset [9]	Pull Type [10]	Power [11]	Hys [12]	Voltage Buffer Type [13]	IO RET [14]
AE8	SERDES0_RX1_N	PCIE1_RXN1	1	I	1.8 V					VDDA_0P8_S ERDES0_1/ VDDA_0P8_S ERDES_C0_1 / VDDA_1P8_S ERDES0_1		4L_PHY	
		USB0_SSRX2N	2	I									
		HYP_RXN1	4	I									
AE9	SERDES0_RX1_P	PCIE1_RXP1	1	I	1.8 V					VDDA_0P8_S ERDES0_1/ VDDA_0P8_S ERDES_C0_1 / VDDA_1P8_S ERDES0_1		4L_PHY	
		USB0_SSRX2P	2	I									
		HYP_RXP1	4	I									
AF6	SERDES0_RX2_N	PCIE1_RXN2	1	I	1.8 V					VDDA_0P8_S ERDES0_1/ VDDA_0P8_S ERDES_C0_1 / VDDA_1P8_S ERDES0_1		4L_PHY	
		USB0_SSRX1N	2	I									
		HYP_RXN2	4	I									
AF7	SERDES0_RX2_P	PCIE1_RXP2	1	I	1.8 V					VDDA_0P8_S ERDES0_1/ VDDA_0P8_S ERDES_C0_1 / VDDA_1P8_S ERDES0_1		4L_PHY	
		USB0_SSRX1P	2	I									
		HYP_RXP2	4	I									
AE5	SERDES0_RX3_N	PCIE1_RXN3	1	I	1.8 V					VDDA_0P8_S ERDES0_1/ VDDA_0P8_S ERDES_C0_1 / VDDA_1P8_S ERDES0_1		4L_PHY	
		USB0_SSRX2N	2	I									
		HYP_RXN3	4	I									
AE6	SERDES0_RX3_P	PCIE1_RXP3	1	I	1.8 V					VDDA_0P8_S ERDES0_1/ VDDA_0P8_S ERDES_C0_1 / VDDA_1P8_S ERDES0_1		4L_PHY	
		USB0_SSRX2P	2	I									
		HYP_RXP3	4	I									
AH7	SERDES0_TX0_N	DP0_TXN0	0	O	1.8 V					VDDA_0P8_S ERDES0_1/ VDDA_0P8_S ERDES_C0_1 / VDDA_1P8_S ERDES0_1		4L_PHY	
		PCIE1_TXN0	1	O									
		USB0_SSTX1N	2	O									
		HYP_TXN0	4	O									

表 6-1. Pin Attributes (ALZ Package) (continued)

Ball Num [1]	Ball Name [2] PADCFG Register [15] PADCFG Address [16]	Signal Name [3]	Mux Mode [4]	Signal Type [5]	I/O Voltage [6]	Ball State DURING Reset (RX/TX/PULL) [7]	Ball State AFTER Reset (RX/TX/PULL) [8]	Mux Mode AFTER Reset [9]	Pull Type [10]	Power [11]	Hys [12]	Voltage Buffer Type [13]	IO RET [14]
AH8	SERDES0_TX0_P	DP0_TXP0	0	O	1.8 V					VDDA_0P8_S ERDES0_1/ VDDA_0P8_S ERDES_C0_1 / VDDA_1P8_S ERDES0_1		4L_PHY	
		PCIE1_TXP0	1	O									
		USB0_SSTX1P	2	O									
		HYP_TXP0	4	O									
AG8	SERDES0_TX1_N	DP0_TXN1	0	O	1.8 V					VDDA_0P8_S ERDES0_1/ VDDA_0P8_S ERDES_C0_1 / VDDA_1P8_S ERDES0_1		4L_PHY	
		PCIE1_TXN1	1	O									
		USB0_SSTX2N	2	O									
		HYP_TXN1	4	O									
AG9	SERDES0_TX1_P	DP0_TXP1	0	O	1.8 V					VDDA_0P8_S ERDES0_1/ VDDA_0P8_S ERDES_C0_1 / VDDA_1P8_S ERDES0_1		4L_PHY	
		PCIE1_TXP1	1	O									
		USB0_SSTX2P	2	O									
		HYP_TXP1	4	O									
AG5	SERDES0_TX2_N	DP0_TXN2	0	O	1.8 V					VDDA_0P8_S ERDES0_1/ VDDA_0P8_S ERDES_C0_1 / VDDA_1P8_S ERDES0_1		4L_PHY	
		PCIE1_TXN2	1	O									
		USB0_SSTX1N	2	O									
		DP0_TXN0	3	O									
		HYP_TXN2	4	O									
AG6	SERDES0_TX2_P	DP0_TXP2	0	O	1.8 V					VDDA_0P8_S ERDES0_1/ VDDA_0P8_S ERDES_C0_1 / VDDA_1P8_S ERDES0_1		4L_PHY	
		PCIE1_TXP2	1	O									
		USB0_SSTX1P	2	O									
		DP0_TXP0	3	O									
		HYP_TXP2	4	O									
AD7	SERDES0_TX3_N	DP0_TXN3	0	O	1.8 V					VDDA_0P8_S ERDES0_1/ VDDA_0P8_S ERDES_C0_1 / VDDA_1P8_S ERDES0_1		4L_PHY	
		PCIE1_TXN3	1	O									
		USB0_SSTX2N	2	O									
		DP0_TXN1	3	O									
		HYP_TXN3	4	O									
AD8	SERDES0_TX3_P	DP0_TXP3	0	O	1.8 V					VDDA_0P8_S ERDES0_1/ VDDA_0P8_S ERDES_C0_1 / VDDA_1P8_S ERDES0_1		4L_PHY	
		PCIE1_TXP3	1	O									
		USB0_SSTX2P	2	O									
		DP0_TXP1	3	O									
		HYP_TXP3	4	O									

**表 6-1. Pin Attributes (ALZ Package) (continued)**

Ball Num [1]	Ball Name [2] PADCFG Register [15] PADCFG Address [16]	Signal Name [3]	Mux Mode [4]	Signal Type [5]	I/O Voltage [6]	Ball State DURING Reset (RX/TX/PULL) [7]	Ball State AFTER Reset (RX/TX/PULL) [8]	Mux Mode AFTER Reset [9]	Pull Type [10]	Power [11]	Hys [12]	Voltage Buffer Type [13]	IO RET [14]
AF25	SOC_SAFETY_ERRORn PADCFG: PADCONFIG_68 0x0011C110	SOC_SAFETY_ERRORn	0	IO	1.8 V/3.3 V	Off / Off / Down	On / SS / Down	0	PU/PD	VDDSHV0	Yes	LVC MOS	No
AH27	SPI0_CLK PADCFG: PADCONFIG_53 0x0011C0D4	SPI0_CLK	0	IO	1.8 V/3.3 V	Off / Off / Off	Off / Off / Off	7	PU/PD	VDDSHV0	Yes	LVC MOS	No
		UART1_CTSn	1	I									
		I2C2_SCL	2	IOD									
		MCASP3_AXR0	3	IO									
		EHRPWM2_A	5	IO									
		GPIO0_53	7	IO									
UART8_TXD	11	O											
AE27	SPI0_CS0 PADCFG: PADCONFIG_51 0x0011C0CC	SPI0_CS0	0	IO	1.8 V/3.3 V	Off / Off / Off	Off / Off / Off	7	PU/PD	VDDSHV0	Yes	LVC MOS	No
		MCASP3_ACLKX	3	IO									
		MCASP3_ACLKR	4	IO									
		EHRPWM0_A	5	IO									
		GPIO0_51	7	IO									
		MCAN14_TX	9	O									
AF26	SPI0_CS1 PADCFG: PADCONFIG_52 0x0011C0D0	SPI0_CS1	0	IO	1.8 V/3.3 V	Off / Off / Off	Off / Off / Off	7	PU/PD	VDDSHV0	Yes	LVC MOS	No
		CPTS0_TS_COMP	1	O									
		UART0_RTSn	2	O									
		MCASP3_AFSX	3	IO									
		MCASP3_AFSR	4	IO									
		EHRPWM1_A	5	IO									
		GPIO0_52	7	IO									
		MCAN14_RX	9	I									
UART8_RXD	11	I											
AG26	SPI0_D0 PADCFG: PADCONFIG_54 0x0011C0D8	SPI0_D0	0	IO	1.8 V/3.3 V	Off / Off / Off	Off / Off / Off	7	PU/PD	VDDSHV0	Yes	LVC MOS	No
		UART1_RTSn	1	O									
		I2C2_SDA	2	IOD									
		MCASP3_AXR1	3	IO									
		EHRPWM3_A	5	IO									
		GPIO0_54	7	IO									
		UART2_RXD	11	I									

表 6-1. Pin Attributes (ALZ Package) (continued)

Ball Num [1]	Ball Name [2] PADCFG Register [15] PADCFG Address [16]	Signal Name [3]	Mux Mode [4]	Signal Type [5]	I/O Voltage [6]	Ball State DURING Reset (RX/TX/PULL) [7]	Ball State AFTER Reset (RX/TX/PULL) [8]	Mux Mode AFTER Reset [9]	Pull Type [10]	Power [11]	Hys [12]	Voltage Buffer Type [13]	IO RET [14]
AH26	SPI0_D1 PADCFG: PADCONFIG_55 0x0011C0DC	SPI0_D1	0	IO	1.8 V/3.3 V	Off / Off / Off	Off / Off / Off	7	PU/PD	VDDSHV0	Yes	LVC MOS	No
		MCASP3_AXR2	3	IO									
		EHRPWM4_A	5	IO									
		GPIO0_55	7	IO									
		UART2_TXD	11	O									
A25	TCK PADCFG: WKUP_PADCONFIG_73 0x4301C124	TCK	0	I	1.8 V/3.3 V	On / NA / Up	On / Off / Up	0	PU/PD	VDDSHV0_MCU	Yes	LVC MOS	No
AG28	TDI PADCFG: PADCONFIG_69 0x0011C114	TDI	0	I	1.8 V/3.3 V	On / Off / Up	On / Off / Up	0	PU/PD	VDDSHV0	Yes	LVC MOS	No
AE26	TDO PADCFG: PADCONFIG_70 0x0011C118	TDO	0	OZ	1.8 V/3.3 V	Off / Off / Up	Off / SS / Up	0	PU/PD	VDDSHV0	Yes	LVC MOS	No
AE25	TIMER_IO0 PADCFG: PADCONFIG_58 0x0011C0E8	TIMER_IO0	0	IO	1.8 V/3.3 V	Off / Off / Off	Off / Off / Off	7	PU/PD	VDDSHV0	Yes	LVC MOS	No
		ECAP1_IN_APWM_OUT	1	IO									
		SYSCLKOUT0	2	O									
		UART3_RXD	5	I									
		PCIE1_CLKREQn	6	IO									
		GPIO0_58	7	IO									
		MMC1_SD CD	8	I									
		MCAN13_TX	9	O									
		I2C6_SDA	13	IOD									
AG25	TIMER_IO1 PADCFG: PADCONFIG_59 0x0011C0EC	TIMER_IO1	0	IO	1.8 V/3.3 V	Off / Off / Off	Off / Off / Off	7	PU/PD	VDDSHV0	Yes	LVC MOS	No
		ECAP2_IN_APWM_OUT	1	IO									
		OB SCLK0	2	O									
		UART3_TXD	5	O									
		USB0_DRVVBUS	6	O									
		GPIO0_59	7	IO									
		MMC1_SD WP	8	I									
		MCAN13_RX	9	I									
		I2C6_SCL	13	IOD									
		OB SCLK0	15	O									
AG27	TMS PADCFG: PADCONFIG_71 0x0011C11C	TMS	0	I	1.8 V/3.3 V	On / Off / Up	On / Off / Up	0	PU/PD	VDDSHV0	Yes	LVC MOS	No

**表 6-1. Pin Attributes (ALZ Package) (continued)**

Ball Num [1]	Ball Name [2] PADCFG Register [15] PADCFG Address [16]	Signal Name [3]	Mux Mode [4]	Signal Type [5]	I/O Voltage [6]	Ball State DURING Reset (RX/TX/PULL) [7]	Ball State AFTER Reset (RX/TX/PULL) [8]	Mux Mode AFTER Reset [9]	Pull Type [10]	Power [11]	Hys [12]	Voltage Buffer Type [13]	IO RET [14]
B28	TRSTn PADCFG: WKUP_PADCONFIG_74 0x4301C128	TRSTn	0	I	1.8 V/3.3 V	On / NA / Down	On / Off / Down	0	PU/PD	VDDSHV0_MCU	Yes	LVC MOS	No
AG2	USB0_DM	USB0_DM		IO	3.3 V					VDDA_0P8_USB / VDDA_1P8_USB / VDDA_3P3_USB		USB2PHY	
AH2	USB0_DP	USB0_DP		IO	3.3 V					VDDA_0P8_USB / VDDA_1P8_USB / VDDA_3P3_USB		USB2PHY	
AC9	USB0_ID	USB0_ID		A	3.3 V					VDDA_0P8_USB / VDDA_1P8_USB / VDDA_3P3_USB		USB2PHY	
AA6	USB0_RCALIB	USB0_RCALIB		A	3.3 V					VDDA_0P8_USB / VDDA_1P8_USB / VDDA_3P3_USB		USB2PHY	
AA8	USB0_VBUS	USB0_VBUS		A	5.0 V					VDDA_0P8_USB / VDDA_1P8_USB / VDDA_3P3_USB		DDR	
N17, V11, V16, Y20	VDDAR_CORE	VDDAR_CORE		PWR									
H9, K14, P11, P14, V13	VDDAR_CPU	VDDAR_CPU		PWR									
K17, K19	VDDAR_MCU	VDDAR_MCU		PWR									
AB14	VDDA_0P8_DSITX	VDDA_0P8_DSITX		PWR									
AB15	VDDA_0P8_DSITX_C	VDDA_0P8_DSITX_C		PWR									
AB8	VDDA_0P8_USB	VDDA_0P8_USB		PWR									
AB17, AB18	VDDA_0P8_CSIRX0_1	VDDA_0P8_CSIRX0_1		PWR									
W7	VDDA_0P8_DLL_MMC0	VDDA_0P8_DLL_MMC0		PWR									
P10	VDDA_0P8_PLL_DDR0	VDDA_0P8_PLL_DDR0		PWR									
J14	VDDA_0P8_PLL_DDR1	VDDA_0P8_PLL_DDR1		PWR									
AB10, AB11	VDDA_0P8_SERDES0_1	VDDA_0P8_SERDES0_1		PWR									

**表 6-1. Pin Attributes (ALZ Package) (continued)**

Ball Num [1]	Ball Name [2] PADCFG Register [15] PADCFG Address [16]	Signal Name [3]	Mux Mode [4]	Signal Type [5]	I/O Voltage [6]	Ball State DURING Reset (RX/TX/PULL) [7]	Ball State AFTER Reset (RX/TX/PULL) [8]	Mux Mode AFTER Reset [9]	Pull Type [10]	Power [11]	Hys [12]	Voltage Buffer Type [13]	IO RET [14]
AA10, AA11	VDDA_0P8_SERDES_C0_1	VDDA_0P8_SERDES_C0_1		PWR									
AA14, AA15	VDDA_1P8_DSITX	VDDA_1P8_DSITX		PWR									
AB7	VDDA_1P8_USB	VDDA_1P8_USB		PWR									
AA17, AA19	VDDA_1P8_CSIRX0_1	VDDA_1P8_CSIRX0_1		PWR									
AA12	VDDA_1P8_SERDES0_1	VDDA_1P8_SERDES0_1		PWR									
AB13	VDDA_1P8_SERDES2_4	VDDA_1P8_SERDES2_4		PWR									
AB9	VDDA_3P3_USB	VDDA_3P3_USB		PWR									
J21	VDDA_ADC0	VDDA_ADC0		PWR									
K21	VDDA_ADC1	VDDA_ADC1		PWR									
K22	VDDA_MCU_PLLGRP0	VDDA_MCU_PLLGRP0		PWR									
J17	VDDA_MCU_TEMP	VDDA_MCU_TEMP		PWR									
L21	VDDA_OSC1	VDDA_OSC1		PWR									
U18	VDDA_PLLGRP0	VDDA_PLLGRP0		PWR									
V19	VDDA_PLLGRP1	VDDA_PLLGRP1		PWR									
Y11	VDDA_PLLGRP2	VDDA_PLLGRP2		PWR									
N14	VDDA_PLLGRP5	VDDA_PLLGRP5		PWR									
R12	VDDA_PLLGRP6	VDDA_PLLGRP6		PWR									
R11	VDDA_PLLGRP7	VDDA_PLLGRP7		PWR									
K12	VDDA_PLLGRP8	VDDA_PLLGRP8		PWR									
T18	VDDA_PLLGRP9	VDDA_PLLGRP9		PWR									
Y16	VDDA_PLLGRP10	VDDA_PLLGRP10		PWR									
Y18	VDDA_PLLGRP12	VDDA_PLLGRP12		PWR									
V12	VDDA_PLLGRP13	VDDA_PLLGRP13		PWR									
L20	VDDA_POR_WKUP	VDDA_POR_WKUP		PWR									
U19	VDDA_TEMP0	VDDA_TEMP0		PWR									
K10	VDDA_TEMP1	VDDA_TEMP1		PWR									
T16	VDDA_TEMP2	VDDA_TEMP2		PWR									
U10	VDDA_TEMP3	VDDA_TEMP3		PWR									
Y14	VDDA_TEMP4	VDDA_TEMP4		PWR									
J22	VDDA_WKUP	VDDA_WKUP		PWR									
R21, U21, U22	VDDSHV0	VDDSHV0		PWR									
H19, H20	VDDSHV0_MCU	VDDSHV0_MCU		PWR									
H16, J16	VDDSHV1_MCU	VDDSHV1_MCU		PWR									
M20, R20	VDDSHV2	VDDSHV2		PWR									
G18, H18	VDDSHV2_MCU	VDDSHV2_MCU		PWR									
M21, N22	VDDSHV5	VDDSHV5		PWR									

**表 6-1. Pin Attributes (ALZ Package) (continued)**

Ball Num [1]	Ball Name [2] PADCFG Register [15] PADCFG Address [16]	Signal Name [3]	Mux Mode [4]	Signal Type [5]	I/O Voltage [6]	Ball State DURING Reset (RX/TX/PULL) [7]	Ball State AFTER Reset (RX/TX/PULL) [8]	Mux Mode AFTER Reset [9]	Pull Type [10]	Power [11]	Hys [12]	Voltage Buffer Type [13]	IO RET [14]
A1, A18, AA1, G10, G12, G14, G6, H11, H13, H15, J6, L6, N6, N9, P7, P8, R6, U9	VDDS_DDR	VDDS_DDR		PWR									
R9	VDDS_DDR_C0	VDDS_DDR_C0		PWR									
J12	VDDS_DDR_C1	VDDS_DDR_C1		PWR									
Y7, Y8	VDDS_MMC0	VDDS_MMC0		PWR									
AA21, AB20, J13, J15, M16, M19, N10, P18, R17, R19, T10, T20, U15, U17, U8, V14, V18, V20, V7, V9, W10, W13, W15, W17, W19, W21, W8, Y12, Y22, Y9	VDD_CORE	VDD_CORE		PWR									
G8, H7, J8, K11, K13, K7, K9, L8, M14, M7, M9, N11, N15, P16, R13, R15, T12, T14, U11, U13	VDD_CPU	VDD_CPU		PWR									
K16, K18, L15, L17, L19	VDD_MCU	VDD_MCU		PWR									
J19	VDD_MCU_WAKE1	VDD_MCU_WAKE1		PWR									
P20	VDD_WAKE0	VDD_WAKE0		PWR									
H23	VMON1_ER_VSYS	VMON1_ER_VSYS		A									
M18	VMON2_IR_VCPU	VMON2_IR_VCPU		A									
L22	VMON3_IR_VEXT1P8	VMON3_IR_VEXT1P8		A									
N19	VMON4_IR_VEXT1P8	VMON4_IR_VEXT1P8		A									
N20	VMON5_IR_VEXT3P3	VMON5_IR_VEXT3P3		A									
L18	VMON6_IR_VEXT0P8	VMON6_IR_VEXT0P8		A									
V22	VPP_CORE	VPP_CORE		PWR									
H22	VPP_MCU	VPP_MCU		PWR									

表 6-1. Pin Attributes (ALZ Package) (continued)

Ball Num [1]	Ball Name [2] PADCFG Register [15] PADCFG Address [16]	Signal Name [3]	Mux Mode [4]	Signal Type [5]	I/O Voltage [6]	Ball State DURING Reset (RX/TX/PULL) [7]	Ball State AFTER Reset (RX/TX/PULL) [8]	Mux Mode AFTER Reset [9]	Pull Type [10]	Power [11]	Hys [12]	Voltage Buffer Type [13]	IO RET [14]
A14, A5, AA13, AA16, AA18, AA20, AA22, AA3, AA5, AA7, AA9, AB12, AB16, AB19, AB2, AB21, AB23, AB4, AB6, AC11, AC22, AC26, AC3, AC5, AC7, AC8, AD15, AD18, AD21, AD6, AD9, AE10, AE14, AE17, AE20, AE23, AE4, AE7, AF12, AF15, AF18, AF21, AF24, AF5, AF8, AG10, AG14, AG17, AG20, AG23, AG4, AG7, AH1, AH12, AH15, AH18, AH21, AH24, AH3, AH6, AH9, B11, B13, B15, B17, B2, B23, B4, B6, B8, C1, C12, C14, C16, C18, C3, C5, C7, D11, D13, D15, D17, D2, D4, D6, D8, E1, E12, E14, E16, E26, E3, E5, E7, F2, F4, F6, G13, G28, G3, G5, G7, G9, H10, H12, H14, H2, H21, H4, H6, H8, J1, J11, J18, J24, J3, J5,	VSS	VSS		GND									

**表 6-1. Pin Attributes (ALZ Package) (continued)**

Ball Num [1]	Ball Name [2] PADCFG Register [15] PADCFG Address [16]	Signal Name [3]	Mux Mode [4]	Signal Type [5]	I/O Voltage [6]	Ball State DURING Reset (RX/TX/PULL) [7]	Ball State AFTER Reset (RX/TX/PULL) [8]	Mux Mode AFTER Reset [9]	Pull Type [10]	Power [11]	Hys [12]	Voltage Buffer Type [13]	IO RET [14]
J7, J9, K15, K2, K20, K27, K4, K6, K8, L14, L16, L3, L5, L7, L9, M15, M17, M2, M25, M4, M6, M8, N1, N16, N18, N21, N23, N3, N7, P15, P17, P19, P22, P6, P9, R10, R14, R16, R18, R23, R26, R7, T11, T13, T15, T17, T19, T2, T22, T4, T6, T9, U12, U14, U16, U20, U23, U3, U5, U7, V10, V15, V17, V2, V21, V24, V4, V6, V8, W1, W11, W12, W14, W16, W18, W20, W22, W26, W3, W6, W9, Y10, Y13, Y15, Y17, Y19, Y2, Y21, Y23, Y4, Y6													
D26	WKUP_GPIO0_0 PADCFG: WKUP_PADCONFIG_48 0x4301C0C0	MCU_SPI1_CLK	0	IO	1.8 V/3.3 V	On / Off / Off	On / Off / Off	7	PU/PD	VDDSHV0_MCU	Yes	LVC MOS	Yes
		MCU_SPI1_CLK	1	IO									
		WKUP_GPIO0_0	7	IO									
		MCU_BOOTMODE03	BOOTS TRAP	I									
E24	WKUP_GPIO0_1 PADCFG: WKUP_PADCONFIG_49 0x4301C0C4	MCU_SPI1_D0	0	IO	1.8 V/3.3 V	On / Off / Off	On / Off / Off	7	PU/PD	VDDSHV0_MCU	Yes	LVC MOS	Yes
		MCU_SPI1_D0	1	IO									
		WKUP_GPIO0_1	7	IO									
		MCU_BOOTMODE04	BOOTS TRAP	I									

表 6-1. Pin Attributes (ALZ Package) (continued)

Ball Num [1]	Ball Name [2] PADCFG Register [15] PADCFG Address [16]	Signal Name [3]	Mux Mode [4]	Signal Type [5]	I/O Voltage [6]	Ball State DURING Reset (RX/TX/PULL) [7]	Ball State AFTER Reset (RX/TX/PULL) [8]	Mux Mode AFTER Reset [9]	Pull Type [10]	Power [11]	Hys [12]	Voltage Buffer Type [13]	IO RET [14]
C28	WKUP_GPIO0_2 PADCFG: WKUP_PADCONFIG_50 0x4301C0C8	MCU_SPI1_D1	0	IO	1.8 V/3.3 V	On / Off / Off	On / Off / Off	7	PU/PD	VDDSHV0_MCU	Yes	LVCMOS	Yes
		MCU_SPI1_D1	1	IO									
		WKUP_GPIO0_2	7	IO									
		MCU_BOOTMODE05	BOOTS TRAP	I									
C27	WKUP_GPIO0_3 PADCFG: WKUP_PADCONFIG_51 0x4301C0CC	MCU_SPI1_CS0	0	IO	1.8 V/3.3 V	Off / Off / Off	Off / Off / Off	7	PU/PD	VDDSHV0_MCU	Yes	LVCMOS	Yes
		MCU_SPI1_CS0	1	IO									
		WKUP_GPIO0_3	7	IO									
C23	WKUP_GPIO0_4 PADCFG: WKUP_PADCONFIG_52 0x4301C0D0	MCU_MCAN1_TX	0	O	1.8 V/3.3 V	Off / Off / Off	Off / Off / Off	7	PU/PD	VDDSHV0_MCU	Yes	LVCMOS	Yes
		MCU_MCAN1_TX	1	O									
		MCU_SPI0_CS3	2	IO									
		MCU_ADC_EXT_TRIGGER0	3	I									
		WKUP_GPIO0_4	7	IO									
F26	WKUP_GPIO0_5 PADCFG: WKUP_PADCONFIG_53 0x4301C0D4	MCU_MCAN1_RX	0	I	1.8 V/3.3 V	Off / Off / Off	Off / Off / Off	7	PU/PD	VDDSHV0_MCU	Yes	LVCMOS	Yes
		MCU_MCAN1_RX	1	I									
		MCU_SPI1_CS3	2	IO									
		MCU_ADC_EXT_TRIGGER1	3	I									
		WKUP_GPIO0_5	7	IO									
E25	WKUP_GPIO0_6 PADCFG: WKUP_PADCONFIG_54 0x4301C0D8	WKUP_UART0_CTSn	0	I	1.8 V/3.3 V	Off / Off / Off	Off / Off / Off	7	PU/PD	VDDSHV0_MCU	Yes	LVCMOS	Yes
		WKUP_UART0_CTSn	1	I									
		MCU_CPTS0_HW1TSPUSH	2	I									
		MCU_I2C1_SCL	3	IOD									
		WKUP_GPIO0_6	7	IO									
F28	WKUP_GPIO0_7 PADCFG: WKUP_PADCONFIG_55 0x4301C0DC	WKUP_UART0_RTSn	0	O	1.8 V/3.3 V	Off / Off / Off	Off / Off / Off	7	PU/PD	VDDSHV0_MCU	Yes	LVCMOS	Yes
		WKUP_UART0_RTSn	1	O									
		MCU_CPTS0_HW2TSPUSH	2	I									
		MCU_I2C1_SDA	3	IOD									
		WKUP_GPIO0_7	7	IO									
F24	WKUP_GPIO0_8 PADCFG: WKUP_PADCONFIG_56 0x4301C0E0	MCU_I2C1_SCL	0	IOD	1.8 V/3.3 V	Off / Off / Off	Off / Off / Off	7	PU/PD	VDDSHV0_MCU	Yes	LVCMOS	Yes
		MCU_I2C1_SCL	1	IOD									
		MCU_CPTS0_TS_SYNC	2	O									
		MCU_I3C0_SCL	3	IO									
		MCU_TIMER_IO6	4	IO									
		WKUP_GPIO0_8	7	IO									

表 6-1. Pin Attributes (ALZ Package) (continued)

Ball Num [1]	Ball Name [2] PADCFG Register [15] PADCFG Address [16]	Signal Name [3]	Mux Mode [4]	Signal Type [5]	I/O Voltage [6]	Ball State DURING Reset (RX/TX/PULL) [7]	Ball State AFTER Reset (RX/TX/PULL) [8]	Mux Mode AFTER Reset [9]	Pull Type [10]	Power [11]	Hys [12]	Voltage Buffer Type [13]	IO RET [14]
H26	WKUP_GPIO0_9 PADCFG: WKUP_PADCONFIG_57 0x4301C0E4	MCU_I2C1_SDA	0	IOD	1.8 V/3.3 V	Off / Off / Off	Off / Off / Off	7	PU/PD	VDDSHV0_MCU	Yes	LVC MOS	Yes
		MCU_I2C1_SDA	1	IOD									
		MCU_CPTS0_TS_COMP	2	O									
		MCU_I3C0_SDA	3	IO									
		MCU_TIMER_I07	4	IO									
MCU_TIMER_I07	7	IO											
F27	WKUP_GPIO0_10 PADCFG: WKUP_PADCONFIG_58 0x4301C0E8	MCU_EXT_REFCLK0	0	I	1.8 V/3.3 V	Off / Off / Off	Off / Off / Off	7	PU/PD	VDDSHV0_MCU	Yes	LVC MOS	Yes
		MCU_EXT_REFCLK0	1	I									
		MCU_UART0_TXD	2	O									
		MCU_ADC_EXT_TRIGGER0	3	I									
		MCU_CPTS0_RFT_CLK	4	I									
		MCU_SYSCLKOUT0	5	O									
MCU_SYSCLKOUT0	7	IO											
F25	WKUP_GPIO0_11 PADCFG: WKUP_PADCONFIG_59 0x4301C0EC	MCU_OBSCLK0	0	O	1.8 V/3.3 V	Off / Off / Off	Off / Off / Off	7	PU/PD	VDDSHV0_MCU	Yes	LVC MOS	Yes
		MCU_OBSCLK0	1	O									
		MCU_UART0_RXD	2	I									
		MCU_ADC_EXT_TRIGGER1	3	I									
		MCU_TIMER_I01	4	IO									
		MCU_I3C0_SDAPULLEN	5	OD									
		MCU_CLKOUT0	6	OZ									
MCU_CLKOUT0	7	IO											
C25	WKUP_GPIO0_12 PADCFG: WKUP_PADCONFIG_60 0x4301C0F0	MCU_UART0_TXD	0	O	1.8 V/3.3 V	On / Off / Off	On / Off / Off	7	PU/PD	VDDSHV0_MCU	Yes	LVC MOS	Yes
		MCU_SPI0_CS1	1	IO									
		WKUP_GPIO0_12	7	IO									
		MCU_BOOTMODE08	BOOTS TRAP	I									
C24	WKUP_GPIO0_13 PADCFG: WKUP_PADCONFIG_61 0x4301C0F4	MCU_UART0_RXD	0	I	1.8 V/3.3 V	On / Off / Off	On / Off / Off	7	PU/PD	VDDSHV0_MCU	Yes	LVC MOS	Yes
		MCU_SPI1_CS1	1	IO									
		WKUP_GPIO0_13	7	IO									
		MCU_BOOTMODE09	BOOTS TRAP	I									
B24	WKUP_GPIO0_14 PADCFG: WKUP_PADCONFIG_62 0x4301C0F8	MCU_UART0_CTSn	0	I	1.8 V/3.3 V	On / Off / Off	On / Off / Off	7	PU/PD	VDDSHV0_MCU	Yes	LVC MOS	Yes
		MCU_SPI0_CS2	1	IO									
		MCU_TIMER_I08	4	IO									
		WKUP_GPIO0_14	7	IO									
MCU_TIMER_I08	7	IO											
MCU_BOOTMODE06	BOOTS TRAP	I											

表 6-1. Pin Attributes (ALZ Package) (continued)

Ball Num [1]	Ball Name [2] PADCFG Register [15] PADCFG Address [16]	Signal Name [3]	Mux Mode [4]	Signal Type [5]	I/O Voltage [6]	Ball State DURING Reset (RX/TX/PULL) [7]	Ball State AFTER Reset (RX/TX/PULL) [8]	Mux Mode AFTER Reset [9]	Pull Type [10]	Power [11]	Hys [12]	Voltage Buffer Type [13]	IO RET [14]
D25	WKUP_GPIO0_15 PADCFG: WKUP_PADCONFIG_63 0x4301C0FC	MCU_UART0_RTSh	0	O	1.8 V/3.3 V	On / Off / Off	On / Off / Off	7	PU/PD	VDDSHV0_MCU	Yes	LVC MOS	Yes
		MCU_SPI1_CS2	1	IO									
		MCU_TIMER_I09	4	IO									
		WKUP_GPIO0_15	7	IO									
		MCU_BOOTMODE07	BOOTS TRAP	I									
K26	WKUP_GPIO0_49 PADCFG: WKUP_PADCONFIG_100 0x4301C190	PMIC_WAKE1	0	O	1.8 V/3.3 V	Off / Off / Off	Off / Off / Off	7	PU/PD	VDDSHV0_MCU	Yes	LVC MOS	No
		MCU_EXT_REFCLK0	1	I									
		MCU_CPTS0_RFT_CLK	2	I									
		WKUP_GPIO0_49	7	IO									
G27	WKUP_GPIO0_56 PADCFG: WKUP_PADCONFIG_72 0x4301C120	MCU_TIMER_I06	4	IO	1.8 V/3.3 V	On / Off / Off	On / Off / Off	7	PU/PD	VDDSHV0_MCU	Yes	LVC MOS	No
		WKUP_GPIO0_56	7	IO									
		BOOTMODE04	BOOTS TRAP	I									
J26	WKUP_GPIO0_57 PADCFG: WKUP_PADCONFIG_95 0x4301C17C	MCU_TIMER_I07	4	IO	1.8 V/3.3 V	On / Off / Off	On / Off / Off	7	PU/PD	VDDSHV0_MCU	Yes	LVC MOS	No
		WKUP_GPIO0_57	7	IO									
		BOOTMODE05	BOOTS TRAP	I									
G25	WKUP_GPIO0_66 PADCFG: WKUP_PADCONFIG_96 0x4301C180	WKUP_GPIO0_66	7	IO	1.8 V/3.3 V	On / Off / Off	On / Off / Off	7	PU/PD	VDDSHV0_MCU	Yes	LVC MOS	Yes
		BOOTMODE06	BOOTS TRAP	I									
J27	WKUP_GPIO0_67 PADCFG: WKUP_PADCONFIG_97 0x4301C184	WKUP_LF_CLKIN	1	I	1.8 V/3.3 V	On / Off / Off	On / Off / Off	7	PU/PD	VDDSHV0_MCU	Yes	LVC MOS	Yes
		WKUP_GPIO0_67	7	IO									
		BOOTMODE07	BOOTS TRAP	I									
H24	WKUP_I2C0_SCL PADCFG: WKUP_PADCONFIG_64 0x4301C100	WKUP_I2C0_SCL	0	IOD	1.8 V/3.3 V	Off / Off / Off	On / SS / Off	0		VDDSHV0_MCU	Yes	I2C OPEN DRAIN	Yes
		WKUP_GPIO0_63	7	IO									
H27	WKUP_I2C0_SDA PADCFG: WKUP_PADCONFIG_65 0x4301C104	WKUP_I2C0_SDA	0	IOD	1.8 V/3.3 V	Off / Off / Off	On / SS / Off	0		VDDSHV0_MCU	Yes	I2C OPEN DRAIN	Yes
		WKUP_GPIO0_64	7	IO									
H28	WKUP_OSC0_XI	WKUP_OSC0_XI		I	1.8 V					VDDA_WKUP	Yes	HFXOSC	No
J28	WKUP_OSC0_XO	WKUP_OSC0_XO		O	1.8 V					VDDA_WKUP	Yes	HFXOSC	No
D28	WKUP_UART0_RXD PADCFG: WKUP_PADCONFIG_44 0x4301C0B0	WKUP_UART0_RXD	0	I	1.8 V/3.3 V	Off / Off / Off	Off / Off / Off	7	PU/PD	VDDSHV0_MCU	Yes	LVC MOS	Yes
		WKUP_GPIO0_58	7	IO									

**表 6-1. Pin Attributes (ALZ Package) (continued)**

Ball Num [1]	Ball Name [2] PADCFG Register [15] PADCFG Address [16]	Signal Name [3]	Mux Mode [4]	Signal Type [5]	I/O Voltage [6]	Ball State DURING Reset (RX/TX/PULL) [7]	Ball State AFTER Reset (RX/TX/PULL) [8]	Mux Mode AFTER Reset [9]	Pull Type [10]	Power [11]	Hys [12]	Voltage Buffer Type [13]	IO RET [14]
D27	WKUP_UART0_TXD PADCFG: WKUP_PADCONFIG_45 0x4301C0B4	WKUP_UART0_TXD	0	O	1.8 V/3.3 V	Off / Off / Off	Off / Off / Off	7	PU/PD	VDDSHV0_MCU	Yes	LVCMOS	Yes
		WKUP_GPIO0_59	7	IO									

## 6.3 Signal Descriptions

1. **SIGNAL NAME:** The name of the signal passing through the pin.

### 备注

Signal names and descriptions provided in each Signal Descriptions table, represent the pin multiplexed signal function which is implemented at the pin and selected via PADCONFIG registers. Device subsystems may provide secondary multiplexing of signal functions, which are not described in these tables. For more information on secondary multiplexed signal functions, see the respective peripheral chapter of the device TRM.

2. **PIN TYPE:** Signal direction and type:

- I = Input
- O = Output
- OD = Output, with open-drain output function
- IO = Input, Output, or simultaneously Input and Output
- IOD = Input, Output, or simultaneously Input and Output with open-drain output function
- IOZ = Input, Output, or simultaneously Input and Output with three-state output function
- OZ = Output with three-state output function
- A = Analog
- PWR = Power
- GND = Ground
- CAP = LDO Capacitor

3. **DESCRIPTION:** Description of the signal

4. **BALL:** Ball number(s) associated with signal

For more information on the IO cell configurations, see the *Pad Configuration Registers* section in *Device Configuration* chapter of the device TRM.

### 6.3.1 ADC

#### 6.3.1.1 MCU Domain

表 6-2. MCU\_ADC Signal Descriptions

SIGNAL NAME [1]	PIN TYPE [2]	DESCRIPTION [3]	ALZ PIN [4]
MCU_ADC_EXT_TRIGGER0	I	ADC Trigger Input	C23, E22, F27
MCU_ADC_EXT_TRIGGER1	I	ADC Trigger Input	E21, F25, F26

表 6-3. MCU\_ADC0 Signal Descriptions

SIGNAL NAME [1]	PIN TYPE [2]	DESCRIPTION [3]	ALZ PIN [4]
MCU_ADC0_AIN0	A	ADC Input 0	L25
MCU_ADC0_AIN1	A	ADC Input 1	K25
MCU_ADC0_AIN2	A	ADC Input 2	M24
MCU_ADC0_AIN3	A	ADC Input 3	L24
MCU_ADC0_AIN4	A	ADC Input 4	L27
MCU_ADC0_AIN5	A	ADC Input 5	K24
MCU_ADC0_AIN6	A	ADC Input 6	M27
MCU_ADC0_AIN7	A	ADC Input 7	M26

**表 6-4. MCU\_ADC1 Signal Descriptions**

SIGNAL NAME [1]	PIN TYPE [2]	DESCRIPTION [3]	ALZ PIN [4]
MCU_ADC1_AIN0	A	ADC Input 0	P25
MCU_ADC1_AIN1	A	ADC Input 1	R25
MCU_ADC1_AIN2	A	ADC Input 2	P28
MCU_ADC1_AIN3	A	ADC Input 3	P27
MCU_ADC1_AIN4	A	ADC Input 4	N25
MCU_ADC1_AIN5	A	ADC Input 5	P26
MCU_ADC1_AIN6	A	ADC Input 6	N26
MCU_ADC1_AIN7	A	ADC Input 7	N27

## 6.3.2 DDRSS

### 6.3.2.1 MAIN Domain

**表 6-5. DDRSS0 Signal Descriptions**

SIGNAL NAME [1] (2)	PIN TYPE [2]	DESCRIPTION [3]	ALZ PIN [4]
DDR0_CKN	IO	DDRSS Differential Clock (negative)	R1
DDR0_CKP	IO	DDRSS Differential Clock (positive)	P1
DDR0_RESETh	IO	DDRSS Reset	R5
DDR0_RET	I	DDR Retention Enable	T8
DDR0_CA0	IO	DDRSS Command Address	P3
DDR0_CA1	IO	DDRSS Command Address	P5
DDR0_CA2	IO	DDRSS Command Address	N5
DDR0_CA3	IO	DDRSS Command Address	P2
DDR0_CA4	IO	DDRSS Command Address	P4
DDR0_CA5	IO	DDRSS Command Address	R3
DDR0_CAL0 (1)	A	IO Pad Calibration Resistor	R8
DDR0_CKE0	IO	DDRSS Clock Enable	R2
DDR0_CKE1	IO	DDRSS Clock Enable	R4
DDR0_CSn0_0	IO	DDRSS Chip Select	V5
DDR0_CSn0_1	IO	DDRSS Chip Select	W5
DDR0_CSn1_0	IO	DDRSS Chip Select	T5
DDR0_CSn1_1	IO	DDRSS Chip Select	U6
DDR0_DM0	IO	DDRSS Data Mask	H5
DDR0_DM1	IO	DDRSS Data Mask	M3
DDR0_DM2	IO	DDRSS Data Mask	U4
DDR0_DM3	IO	DDRSS Data Mask	AD1
DDR0_DQ0	IO	DDRSS Data	F3
DDR0_DQ1	IO	DDRSS Data	G4
DDR0_DQ2	IO	DDRSS Data	F5
DDR0_DQ3	IO	DDRSS Data	F1
DDR0_DQ4	IO	DDRSS Data	J4
DDR0_DQ5	IO	DDRSS Data	H3
DDR0_DQ6	IO	DDRSS Data	J2
DDR0_DQ7	IO	DDRSS Data	G2
DDR0_DQ8	IO	DDRSS Data	K5
DDR0_DQ9	IO	DDRSS Data	M5
DDR0_DQ10	IO	DDRSS Data	K3

表 6-5. DDRSS0 Signal Descriptions (continued)

SIGNAL NAME [1] <sup>(2)</sup>	PIN TYPE [2]	DESCRIPTION [3]	ALZ PIN [4]
DDR0_DQ11	IO	DDRSS Data	K1
DDR0_DQ12	IO	DDRSS Data	N4
DDR0_DQ13	IO	DDRSS Data	N2
DDR0_DQ14	IO	DDRSS Data	L4
DDR0_DQ15	IO	DDRSS Data	L2
DDR0_DQ16	IO	DDRSS Data	T1
DDR0_DQ17	IO	DDRSS Data	T3
DDR0_DQ18	IO	DDRSS Data	V3
DDR0_DQ19	IO	DDRSS Data	U2
DDR0_DQ20	IO	DDRSS Data	W2
DDR0_DQ21	IO	DDRSS Data	W4
DDR0_DQ22	IO	DDRSS Data	Y1
DDR0_DQ23	IO	DDRSS Data	Y3
DDR0_DQ24	IO	DDRSS Data	AB3
DDR0_DQ25	IO	DDRSS Data	AA2
DDR0_DQ26	IO	DDRSS Data	AA4
DDR0_DQ27	IO	DDRSS Data	Y5
DDR0_DQ28	IO	DDRSS Data	AC2
DDR0_DQ29	IO	DDRSS Data	AB5
DDR0_DQ30	IO	DDRSS Data	AD2
DDR0_DQ31	IO	DDRSS Data	AC4
DDR0_QS0N	IO	DDRSS Complimentary Data Strobe	H1
DDR0_QS0P	IO	DDRSS Data Strobe	G1
DDR0_QS1N	IO	DDRSS Complimentary Data Strobe	M1
DDR0_QS1P	IO	DDRSS Data Strobe	L1
DDR0_QS2N	IO	DDRSS Complimentary Data Strobe	U1
DDR0_QS2P	IO	DDRSS Data Strobe	V1
DDR0_QS3N	IO	DDRSS Complimentary Data Strobe	AC1
DDR0_QS3P	IO	DDRSS Data Strobe	AB1

(1) An external 240  $\Omega$   $\pm$ 1% resistor must be connected between this pin and VSS. No external voltage should be applied to this pin.

(2) DDRSS0 and DDRSS1 must always be used in incremental order. For instance, when using a single LPDDR component, it must be connected to the DDR0\_\* interface. When using two LPDDR components, they must be connected to DDR0\_\* and DDR1\_\* interfaces.

表 6-6. DDRSS1 Signal Descriptions

SIGNAL NAME [1] <sup>(2)</sup>	PIN TYPE [2]	DESCRIPTION [3]	ALZ PIN [4]
DDR1_CKN	IO	DDRSS Differential Clock (negative)	A9
DDR1_CKP	IO	DDRSS Differential Clock (positive)	A10
DDR1_RESETh	IO	DDRSS Reset	F12
DDR1_RET	I	DDR Retention Enable	J10
DDR1_CA0	IO	DDRSS Command Address	C10
DDR1_CA1	IO	DDRSS Command Address	E10
DDR1_CA2	IO	DDRSS Command Address	E9
DDR1_CA3	IO	DDRSS Command Address	B10
DDR1_CA4	IO	DDRSS Command Address	D10
DDR1_CA5	IO	DDRSS Command Address	C9
DDR1_CAL0 <sup>(1)</sup>	A	IO Pad Calibration Resistor	E8

**表 6-6. DDRSS1 Signal Descriptions (continued)**

SIGNAL NAME [1] <sup>(2)</sup>	PIN TYPE [2]	DESCRIPTION [3]	ALZ PIN [4]
DDR1_CKE0	IO	DDRSS Clock Enable	B9
DDR1_CKE1	IO	DDRSS Clock Enable	D9
DDR1_CSn0_0	IO	DDRSS Chip Select	F9
DDR1_CSn0_1	IO	DDRSS Chip Select	F8
DDR1_CSn1_0	IO	DDRSS Chip Select	F11
DDR1_CSn1_1	IO	DDRSS Chip Select	F10
DDR1_DM0	IO	DDRSS Data Mask	D16
DDR1_DM1	IO	DDRSS Data Mask	E13
DDR1_DM2	IO	DDRSS Data Mask	F7
DDR1_DM3	IO	DDRSS Data Mask	B3
DDR1_DQ0	IO	DDRSS Data	B18
DDR1_DQ1	IO	DDRSS Data	E17
DDR1_DQ2	IO	DDRSS Data	D18
DDR1_DQ3	IO	DDRSS Data	A17
DDR1_DQ4	IO	DDRSS Data	E15
DDR1_DQ5	IO	DDRSS Data	B16
DDR1_DQ6	IO	DDRSS Data	C15
DDR1_DQ7	IO	DDRSS Data	C17
DDR1_DQ8	IO	DDRSS Data	B14
DDR1_DQ9	IO	DDRSS Data	D14
DDR1_DQ10	IO	DDRSS Data	C13
DDR1_DQ11	IO	DDRSS Data	C11
DDR1_DQ12	IO	DDRSS Data	E11
DDR1_DQ13	IO	DDRSS Data	A11
DDR1_DQ14	IO	DDRSS Data	B12
DDR1_DQ15	IO	DDRSS Data	D12
DDR1_DQ16	IO	DDRSS Data	B7
DDR1_DQ17	IO	DDRSS Data	D7
DDR1_DQ18	IO	DDRSS Data	C8
DDR1_DQ19	IO	DDRSS Data	A8
DDR1_DQ20	IO	DDRSS Data	C6
DDR1_DQ21	IO	DDRSS Data	E6
DDR1_DQ22	IO	DDRSS Data	B5
DDR1_DQ23	IO	DDRSS Data	D5
DDR1_DQ24	IO	DDRSS Data	B1
DDR1_DQ25	IO	DDRSS Data	A4
DDR1_DQ26	IO	DDRSS Data	C4
DDR1_DQ27	IO	DDRSS Data	E4
DDR1_DQ28	IO	DDRSS Data	D1
DDR1_DQ29	IO	DDRSS Data	D3
DDR1_DQ30	IO	DDRSS Data	C2
DDR1_DQ31	IO	DDRSS Data	E2
DDR1_DQS0N	IO	DDRSS Complimentary Data Strobe	A15
DDR1_DQS0P	IO	DDRSS Data Strobe	A16
DDR1_DQS1N	IO	DDRSS Complimentary Data Strobe	A12

表 6-6. DDRSS1 Signal Descriptions (continued)

SIGNAL NAME [1] <sup>(2)</sup>	PIN TYPE [2]	DESCRIPTION [3]	ALZ PIN [4]
DDR1_DQS1P	IO	DDRSS Data Strobe	A13
DDR1_DQS2N	IO	DDRSS Complimentary Data Strobe	A7
DDR1_DQS2P	IO	DDRSS Data Strobe	A6
DDR1_DQS3N	IO	DDRSS Complimentary Data Strobe	A2
DDR1_DQS3P	IO	DDRSS Data Strobe	A3

(1) An external 240  $\Omega$   $\pm$ 1% resistor must be connected between this pin and VSS. No external voltage should be applied to this pin.

(2) DDRSS0 and DDRSS1 must always be used in incremental order. For instance, when using a single LPDDR component, it must be connected to the DDR0\_\* interface. When using two LPDDR components, they must be connected to DDR0\_\* and DDR1\_\* interfaces.

### 6.3.3 GPIO

#### 6.3.3.1 MAIN Domain

表 6-7. GPIO0 Signal Descriptions

SIGNAL NAME [1]	PIN TYPE [2]	DESCRIPTION [3]	ALZ PIN [4]
GPIO0_0	IO	General Purpose Input/Output	AG24
GPIO0_1	IO	General Purpose Input/Output	W25
GPIO0_2	IO	General Purpose Input/Output	AC24
GPIO0_3	IO	General Purpose Input/Output	AE28
GPIO0_4	IO	General Purpose Input/Output	AF28
GPIO0_5	IO	General Purpose Input/Output	AD25
GPIO0_6	IO	General Purpose Input/Output	W23
GPIO0_7	IO	General Purpose Input/Output	Y24
GPIO0_8	IO	General Purpose Input/Output	AA23
GPIO0_9	IO	General Purpose Input/Output	Y28
GPIO0_10	IO	General Purpose Input/Output	AB24
GPIO0_11	IO	General Purpose Input/Output	V23
GPIO0_12	IO	General Purpose Input/Output	T26
GPIO0_13	IO	General Purpose Input/Output	AD24
GPIO0_14	IO	General Purpose Input/Output	AB28
GPIO0_15	IO	General Purpose Input/Output	U27
GPIO0_16	IO	General Purpose Input/Output	AC28
GPIO0_17	IO	General Purpose Input/Output	Y26
GPIO0_18	IO	General Purpose Input/Output	AB27
GPIO0_19	IO	General Purpose Input/Output	V27
GPIO0_20	IO	General Purpose Input/Output	W27
GPIO0_21	IO	General Purpose Input/Output	Y27
GPIO0_22	IO	General Purpose Input/Output	AA27
GPIO0_23	IO	General Purpose Input/Output	AA26
GPIO0_24	IO	General Purpose Input/Output	AC27
GPIO0_25	IO	General Purpose Input/Output	W28
GPIO0_26	IO	General Purpose Input/Output	U28
GPIO0_27	IO	General Purpose Input/Output	V26
GPIO0_28	IO	General Purpose Input/Output	R27
GPIO0_29	IO	General Purpose Input/Output	R28
GPIO0_30	IO	General Purpose Input/Output	Y25
GPIO0_31	IO	General Purpose Input/Output	T27

**表 6-7. GPIO0 Signal Descriptions (continued)**

SIGNAL NAME [1]	PIN TYPE [2]	DESCRIPTION [3]	ALZ PIN [4]
GPIO0_32	IO	General Purpose Input/Output	U26
GPIO0_33	IO	General Purpose Input/Output	AA28
GPIO0_34	IO	General Purpose Input/Output	AD27
GPIO0_35	IO	General Purpose Input/Output	T25
GPIO0_36	IO	General Purpose Input/Output	W24
GPIO0_37	IO	General Purpose Input/Output	AA25
GPIO0_38	IO	General Purpose Input/Output	V25
GPIO0_39	IO	General Purpose Input/Output	T24
GPIO0_40	IO	General Purpose Input/Output	AB25
GPIO0_41	IO	General Purpose Input/Output	T23
GPIO0_42	IO	General Purpose Input/Output	U24
GPIO0_43	IO	General Purpose Input/Output	AC25
GPIO0_44	IO	General Purpose Input/Output	AD26
GPIO0_45	IO	General Purpose Input/Output	U25
GPIO0_46	IO	General Purpose Input/Output	AA24
GPIO0_47	IO	General Purpose Input/Output	V28
GPIO0_48	IO	General Purpose Input/Output	T28
GPIO0_49	IO	General Purpose Input/Output	AB26
GPIO0_50	IO	General Purpose Input/Output	AD28
GPIO0_51	IO	General Purpose Input/Output	AE27
GPIO0_52	IO	General Purpose Input/Output	AF26
GPIO0_53	IO	General Purpose Input/Output	AH27
GPIO0_54	IO	General Purpose Input/Output	AG26
GPIO0_55	IO	General Purpose Input/Output	AH26
GPIO0_56	IO	General Purpose Input/Output	AH25
GPIO0_57	IO	General Purpose Input/Output	AE24
GPIO0_58	IO	General Purpose Input/Output	AE25
GPIO0_59	IO	General Purpose Input/Output	AG25
GPIO0_60	IO	General Purpose Input/Output	R22
GPIO0_61	IO	General Purpose Input/Output	R24
GPIO0_62	IO	General Purpose Input/Output	P24
GPIO0_63	IO	General Purpose Input/Output	M23
GPIO0_64	IO	General Purpose Input/Output	P23
GPIO0_65	IO	General Purpose Input/Output	N24

### 6.3.3.2 WKUP Domain

**表 6-8. WKUP\_GPIO0 Signal Descriptions**

SIGNAL NAME [1]	PIN TYPE [2]	DESCRIPTION [3]	ALZ PIN [4]
WKUP_GPIO0_0	IO	General Purpose Input/Output	D26
WKUP_GPIO0_1	IO	General Purpose Input/Output	E24
WKUP_GPIO0_2	IO	General Purpose Input/Output	C28
WKUP_GPIO0_3	IO	General Purpose Input/Output	C27
WKUP_GPIO0_4	IO	General Purpose Input/Output	C23
WKUP_GPIO0_5	IO	General Purpose Input/Output	F26
WKUP_GPIO0_6	IO	General Purpose Input/Output	E25

表 6-8. WKUP\_GPIO0 Signal Descriptions (continued)

SIGNAL NAME [1]	PIN TYPE [2]	DESCRIPTION [3]	ALZ PIN [4]
WKUP_GPIO0_7	IO	General Purpose Input/Output	F28
WKUP_GPIO0_8	IO	General Purpose Input/Output	F24
WKUP_GPIO0_9	IO	General Purpose Input/Output	H26
WKUP_GPIO0_10	IO	General Purpose Input/Output	F27
WKUP_GPIO0_11	IO	General Purpose Input/Output	F25
WKUP_GPIO0_12	IO	General Purpose Input/Output	C25
WKUP_GPIO0_13	IO	General Purpose Input/Output	C24
WKUP_GPIO0_14	IO	General Purpose Input/Output	B24
WKUP_GPIO0_15	IO	General Purpose Input/Output	D25
WKUP_GPIO0_16	IO	General Purpose Input/Output	D19
WKUP_GPIO0_17	IO	General Purpose Input/Output	E20
WKUP_GPIO0_18	IO	General Purpose Input/Output	E18
WKUP_GPIO0_19	IO	General Purpose Input/Output	C19
WKUP_GPIO0_20	IO	General Purpose Input/Output	F16
WKUP_GPIO0_21	IO	General Purpose Input/Output	G15
WKUP_GPIO0_22	IO	General Purpose Input/Output	F18
WKUP_GPIO0_23	IO	General Purpose Input/Output	E19
WKUP_GPIO0_24	IO	General Purpose Input/Output	G19
WKUP_GPIO0_25	IO	General Purpose Input/Output	F19
WKUP_GPIO0_26	IO	General Purpose Input/Output	F20
WKUP_GPIO0_27	IO	General Purpose Input/Output	F15
WKUP_GPIO0_28	IO	General Purpose Input/Output	G17
WKUP_GPIO0_29	IO	General Purpose Input/Output	F14
WKUP_GPIO0_30	IO	General Purpose Input/Output	F17
WKUP_GPIO0_31	IO	General Purpose Input/Output	A19
WKUP_GPIO0_32	IO	General Purpose Input/Output	B20
WKUP_GPIO0_33	IO	General Purpose Input/Output	B19
WKUP_GPIO0_34	IO	General Purpose Input/Output	D21
WKUP_GPIO0_35	IO	General Purpose Input/Output	G20
WKUP_GPIO0_36	IO	General Purpose Input/Output	C20
WKUP_GPIO0_37	IO	General Purpose Input/Output	A20
WKUP_GPIO0_38	IO	General Purpose Input/Output	D20
WKUP_GPIO0_39	IO	General Purpose Input/Output	C21
WKUP_GPIO0_40	IO	General Purpose Input/Output	F22
WKUP_GPIO0_41	IO	General Purpose Input/Output	E23
WKUP_GPIO0_42	IO	General Purpose Input/Output	E22
WKUP_GPIO0_43	IO	General Purpose Input/Output	E21
WKUP_GPIO0_44	IO	General Purpose Input/Output	G22
WKUP_GPIO0_45	IO	General Purpose Input/Output	F23
WKUP_GPIO0_46	IO	General Purpose Input/Output	F21
WKUP_GPIO0_47	IO	General Purpose Input/Output	D22
WKUP_GPIO0_48	IO	General Purpose Input/Output	D23
WKUP_GPIO0_49	IO	General Purpose Input/Output	K26
WKUP_GPIO0_50	IO	General Purpose Input/Output	B21
WKUP_GPIO0_51	IO	General Purpose Input/Output	B22

**表 6-8. WKUP\_GPIO0 Signal Descriptions (continued)**

SIGNAL NAME [1]	PIN TYPE [2]	DESCRIPTION [3]	ALZ PIN [4]
WKUP_GPIO0_52	IO	General Purpose Input/Output	A22
WKUP_GPIO0_53	IO	General Purpose Input/Output	A21
WKUP_GPIO0_54	IO	General Purpose Input/Output	B27
WKUP_GPIO0_55	IO	General Purpose Input/Output	D24
WKUP_GPIO0_56	IO	General Purpose Input/Output	G27
WKUP_GPIO0_57	IO	General Purpose Input/Output	J26
WKUP_GPIO0_58	IO	General Purpose Input/Output	D28
WKUP_GPIO0_59	IO	General Purpose Input/Output	D27
WKUP_GPIO0_60	IO	General Purpose Input/Output	E27
WKUP_GPIO0_61	IO	General Purpose Input/Output	E28
WKUP_GPIO0_62	IO	General Purpose Input/Output	C22
WKUP_GPIO0_63	IO	General Purpose Input/Output	H24
WKUP_GPIO0_64	IO	General Purpose Input/Output	H27
WKUP_GPIO0_65	IO	General Purpose Input/Output	G24
WKUP_GPIO0_66	IO	General Purpose Input/Output	G25
WKUP_GPIO0_67	IO	General Purpose Input/Output	J27
WKUP_GPIO0_68	IO	General Purpose Input/Output	A23
WKUP_GPIO0_69	IO	General Purpose Input/Output	B25
WKUP_GPIO0_70	IO	General Purpose Input/Output	B26
WKUP_GPIO0_71	I	General Purpose Input/Output	L25
WKUP_GPIO0_72	I	General Purpose Input/Output	K25
WKUP_GPIO0_73	I	General Purpose Input/Output	M24
WKUP_GPIO0_74	I	General Purpose Input/Output	L24
WKUP_GPIO0_75	I	General Purpose Input/Output	L27
WKUP_GPIO0_76	I	General Purpose Input/Output	K24
WKUP_GPIO0_77	I	General Purpose Input/Output	M27
WKUP_GPIO0_78	I	General Purpose Input/Output	M26
WKUP_GPIO0_79	I	General Purpose Input/Output	P25
WKUP_GPIO0_80	I	General Purpose Input/Output	R25
WKUP_GPIO0_81	I	General Purpose Input/Output	P28
WKUP_GPIO0_82	I	General Purpose Input/Output	P27
WKUP_GPIO0_83	I	General Purpose Input/Output	N25
WKUP_GPIO0_84	I	General Purpose Input/Output	P26
WKUP_GPIO0_85	I	General Purpose Input/Output	N26
WKUP_GPIO0_86	I	General Purpose Input/Output	N27
WKUP_GPIO0_87	IO	General Purpose Input/Output	J25
WKUP_GPIO0_88	IO	General Purpose Input/Output	G26

### 6.3.4 I2C

#### 6.3.4.1 MAIN Domain

**表 6-9. I2C0 Signal Descriptions**

SIGNAL NAME [1]	PIN TYPE [2]	DESCRIPTION [3]	ALZ PIN [4]
I2C0_SCL	IOD	I2C Clock	AH25
I2C0_SDA	IOD	I2C Data	AE24

表 6-10. I2C1 Signal Descriptions

SIGNAL NAME [1]	PIN TYPE [2]	DESCRIPTION [3]	ALZ PIN [4]
I2C1_SCL	IOD	I2C Clock	AA23, AB26, AC25
I2C1_SDA	IOD	I2C Data	AD26, AD28, Y28

表 6-11. I2C2 Signal Descriptions

SIGNAL NAME [1]	PIN TYPE [2]	DESCRIPTION [3]	ALZ PIN [4]
I2C2_SCL	IOD	I2C Clock	AH27, V27
I2C2_SDA	IOD	I2C Data	AG26, W27

表 6-12. I2C3 Signal Descriptions

SIGNAL NAME [1]	PIN TYPE [2]	DESCRIPTION [3]	ALZ PIN [4]
I2C3_SCL	IOD	I2C Clock	R22, W28
I2C3_SDA	IOD	I2C Data	AC27, R24

表 6-13. I2C4 Signal Descriptions

SIGNAL NAME [1]	PIN TYPE [2]	DESCRIPTION [3]	ALZ PIN [4]
I2C4_SCL	IOD	I2C Clock	AA28, AD25, M23
I2C4_SDA	IOD	I2C Data	AF28, P24, U26

表 6-14. I2C5 Signal Descriptions

SIGNAL NAME [1]	PIN TYPE [2]	DESCRIPTION [3]	ALZ PIN [4]
I2C5_SCL	IOD	I2C Clock	R28, Y24
I2C5_SDA	IOD	I2C Data	W23, Y25

表 6-15. I2C6 Signal Descriptions

SIGNAL NAME [1]	PIN TYPE [2]	DESCRIPTION [3]	ALZ PIN [4]
I2C6_SCL	IOD	I2C Clock	AG25, N24
I2C6_SDA	IOD	I2C Data	AE25, P23

### 6.3.4.2 MCU Domain

表 6-16. MCU\_I2C0 Signal Descriptions

SIGNAL NAME [1]	PIN TYPE [2]	DESCRIPTION [3]	ALZ PIN [4]
MCU_I2C0_SCL	IOD	I2C Clock	G24
MCU_I2C0_SDA	IOD	I2C Data	J25

表 6-17. MCU\_I2C1 Signal Descriptions

SIGNAL NAME [1]	PIN TYPE [2]	DESCRIPTION [3]	ALZ PIN [4]
MCU_I2C1_SCL	IOD	I2C Clock	E25, F24
MCU_I2C1_SDA	IOD	I2C Data	F28, H26

### 6.3.4.3 WKUP Domain

表 6-18. WKUP\_I2C0 Signal Descriptions

SIGNAL NAME [1]	PIN TYPE [2]	DESCRIPTION [3]	ALZ PIN [4]
WKUP_I2C0_SCL	IOD	I2C Clock	H24
WKUP_I2C0_SDA	IOD	I2C Data	H27

## 6.3.5 I3C

### 6.3.5.1 MCU Domain

**表 6-19. MCU\_I3C0 Signal Descriptions**

SIGNAL NAME [1]	PIN TYPE [2]	DESCRIPTION [3]	ALZ PIN [4]
MCU_I3C0_SCL	IO	I3C Clock	F24
MCU_I3C0_SDA	IO	I3C Data	H26
MCU_I3C0_SDAPULLEN	OD	I3C Data Pull Enable	F25, G26

## 6.3.6 MCAN

### 6.3.6.1 MAIN Domain

**表 6-20. MCAN0 Signal Descriptions**

SIGNAL NAME [1]	PIN TYPE [2]	DESCRIPTION [3]	ALZ PIN [4]
MCAN0_RX	I	MCAN Receive Data	U28
MCAN0_TX	O	MCAN Transmit Data	W28

**表 6-21. MCAN1 Signal Descriptions**

SIGNAL NAME [1]	PIN TYPE [2]	DESCRIPTION [3]	ALZ PIN [4]
MCAN1_RX	I	MCAN Receive Data	AD28, R27
MCAN1_TX	O	MCAN Transmit Data	V26

**表 6-22. MCAN2 Signal Descriptions**

SIGNAL NAME [1]	PIN TYPE [2]	DESCRIPTION [3]	ALZ PIN [4]
MCAN2_RX	I	MCAN Receive Data	Y25
MCAN2_TX	O	MCAN Transmit Data	R28

**表 6-23. MCAN3 Signal Descriptions**

SIGNAL NAME [1]	PIN TYPE [2]	DESCRIPTION [3]	ALZ PIN [4]
MCAN3_RX	I	MCAN Receive Data	U26
MCAN3_TX	O	MCAN Transmit Data	T27

**表 6-24. MCAN4 Signal Descriptions**

SIGNAL NAME [1]	PIN TYPE [2]	DESCRIPTION [3]	ALZ PIN [4]
MCAN4_RX	I	MCAN Receive Data	AD27
MCAN4_TX	O	MCAN Transmit Data	AA28

**表 6-25. MCAN5 Signal Descriptions**

SIGNAL NAME [1]	PIN TYPE [2]	DESCRIPTION [3]	ALZ PIN [4]
MCAN5_RX	I	MCAN Receive Data	U27, W24
MCAN5_TX	O	MCAN Transmit Data	AB28, T25

**表 6-26. MCAN6 Signal Descriptions**

SIGNAL NAME [1]	PIN TYPE [2]	DESCRIPTION [3]	ALZ PIN [4]
MCAN6_RX	I	MCAN Receive Data	V25, Y26
MCAN6_TX	O	MCAN Transmit Data	AA25, AC28

表 6-27. MCAN7 Signal Descriptions

SIGNAL NAME [1]	PIN TYPE [2]	DESCRIPTION [3]	ALZ PIN [4]
MCAN7_RX	I	MCAN Receive Data	AB25, V27
MCAN7_TX	O	MCAN Transmit Data	AB27, T24

表 6-28. MCAN8 Signal Descriptions

SIGNAL NAME [1]	PIN TYPE [2]	DESCRIPTION [3]	ALZ PIN [4]
MCAN8_RX	I	MCAN Receive Data	U24, Y27
MCAN8_TX	O	MCAN Transmit Data	T23, W27

表 6-29. MCAN9 Signal Descriptions

SIGNAL NAME [1]	PIN TYPE [2]	DESCRIPTION [3]	ALZ PIN [4]
MCAN9_RX	I	MCAN Receive Data	AA26, AD26
MCAN9_TX	O	MCAN Transmit Data	AA27, AC25

表 6-30. MCAN10 Signal Descriptions

SIGNAL NAME [1]	PIN TYPE [2]	DESCRIPTION [3]	ALZ PIN [4]
MCAN10_RX	I	MCAN Receive Data	AA24
MCAN10_TX	O	MCAN Transmit Data	U25

表 6-31. MCAN11 Signal Descriptions

SIGNAL NAME [1]	PIN TYPE [2]	DESCRIPTION [3]	ALZ PIN [4]
MCAN11_RX	I	MCAN Receive Data	T28
MCAN11_TX	O	MCAN Transmit Data	V28

表 6-32. MCAN12 Signal Descriptions

SIGNAL NAME [1]	PIN TYPE [2]	DESCRIPTION [3]	ALZ PIN [4]
MCAN12_RX	I	MCAN Receive Data	AC24, T26
MCAN12_TX	O	MCAN Transmit Data	AB26, W25

表 6-33. MCAN13 Signal Descriptions

SIGNAL NAME [1]	PIN TYPE [2]	DESCRIPTION [3]	ALZ PIN [4]
MCAN13_RX	I	MCAN Receive Data	AF28, AG25
MCAN13_TX	O	MCAN Transmit Data	AE25, AE28

表 6-34. MCAN14 Signal Descriptions

SIGNAL NAME [1]	PIN TYPE [2]	DESCRIPTION [3]	ALZ PIN [4]
MCAN14_RX	I	MCAN Receive Data	AF26, W23
MCAN14_TX	O	MCAN Transmit Data	AD25, AE27

表 6-35. MCAN15 Signal Descriptions

SIGNAL NAME [1]	PIN TYPE [2]	DESCRIPTION [3]	ALZ PIN [4]
MCAN15_RX	I	MCAN Receive Data	AA23, N24
MCAN15_TX	O	MCAN Transmit Data	P23, Y24

**表 6-36. MCAN16 Signal Descriptions**

SIGNAL NAME [1]	PIN TYPE [2]	DESCRIPTION [3]	ALZ PIN [4]
MCAN16_RX	I	MCAN Receive Data	AB24
MCAN16_TX	O	MCAN Transmit Data	Y28

**表 6-37. MCAN17 Signal Descriptions**

SIGNAL NAME [1]	PIN TYPE [2]	DESCRIPTION [3]	ALZ PIN [4]
MCAN17_RX	I	MCAN Receive Data	AC27, AD24
MCAN17_TX	O	MCAN Transmit Data	V23

### 6.3.6.2 MCU Domain

**表 6-38. MCU\_MCAN0 Signal Descriptions**

SIGNAL NAME [1]	PIN TYPE [2]	DESCRIPTION [3]	ALZ PIN [4]
MCU_MCAN0_RX	I	MCAN Receive Data	E28
MCU_MCAN0_TX	O	MCAN Transmit Data	E27

**表 6-39. MCU\_MCAN1 Signal Descriptions**

SIGNAL NAME [1]	PIN TYPE [2]	DESCRIPTION [3]	ALZ PIN [4]
MCU_MCAN1_RX	I	MCAN Receive Data	F26
MCU_MCAN1_TX	O	MCAN Transmit Data	C23

### 6.3.7 MCSPI

#### 6.3.7.1 MAIN Domain

**表 6-40. MCSPI0 Signal Descriptions**

SIGNAL NAME [1]	PIN TYPE [2]	DESCRIPTION [3]	ALZ PIN [4]
SPI0_CLK	IO	SPI Clock	AH27
SPI0_CS0	IO	SPI Chip Select 0	AE27
SPI0_CS1	IO	SPI Chip Select 1	AF26
SPI0_CS2	IO	SPI Chip Select 2	AA23
SPI0_CS3	IO	SPI Chip Select 3	AB24
SPI0_D0	IO	SPI Data 0	AG26
SPI0_D1	IO	SPI Data 1	AH26

**表 6-41. MCSPI1 Signal Descriptions**

SIGNAL NAME [1]	PIN TYPE [2]	DESCRIPTION [3]	ALZ PIN [4]
SPI1_CLK	IO	SPI Clock	P23
SPI1_CS0	IO	SPI Chip Select 0	R22
SPI1_CS1	IO	SPI Chip Select 1	R24
SPI1_CS2	IO	SPI Chip Select 2	P24
SPI1_CS3	IO	SPI Chip Select 3	Y28
SPI1_D0	IO	SPI Data 0	M23
SPI1_D1	IO	SPI Data 1	N24

**表 6-42. MCSPI2 Signal Descriptions**

SIGNAL NAME [1]	PIN TYPE [2]	DESCRIPTION [3]	ALZ PIN [4]
SPI2_CLK	IO	SPI Clock	AB25
SPI2_CS0	IO	SPI Chip Select 0	T23

表 6-42. MCSPI2 Signal Descriptions (continued)

SIGNAL NAME [1]	PIN TYPE [2]	DESCRIPTION [3]	ALZ PIN [4]
SPI2_CS1	IO	SPI Chip Select 1	T24
SPI2_CS2	IO	SPI Chip Select 2	AC28
SPI2_CS3	IO	SPI Chip Select 3	Y26
SPI2_D0	IO	SPI Data 0	U24
SPI2_D1	IO	SPI Data 1	AC25

表 6-43. MCSPI3 Signal Descriptions

SIGNAL NAME [1]	PIN TYPE [2]	DESCRIPTION [3]	ALZ PIN [4]
SPI3_CLK	IO	SPI Clock	T28
SPI3_CS0	IO	SPI Chip Select 0	V28
SPI3_CS1	IO	SPI Chip Select 1	T27
SPI3_CS2	IO	SPI Chip Select 2	AD27
SPI3_CS3	IO	SPI Chip Select 3	AA24
SPI3_D0	IO	SPI Data 0	V27
SPI3_D1	IO	SPI Data 1	W27

表 6-44. MCSPI5 Signal Descriptions

SIGNAL NAME [1]	PIN TYPE [2]	DESCRIPTION [3]	ALZ PIN [4]
SPI5_CLK	IO	SPI Clock	T27
SPI5_CS0	IO	SPI Chip Select 0	U28
SPI5_CS1	IO	SPI Chip Select 1	W28
SPI5_CS2	IO	SPI Chip Select 2	Y27
SPI5_CS3	IO	SPI Chip Select 3	AA27
SPI5_D0	IO	SPI Data 0	R27
SPI5_D1	IO	SPI Data 1	AD27

表 6-45. MCSPI6 Signal Descriptions

SIGNAL NAME [1]	PIN TYPE [2]	DESCRIPTION [3]	ALZ PIN [4]
SPI6_CLK	IO	SPI Clock	T26
SPI6_CS0	IO	SPI Chip Select 0	AD24
SPI6_CS1	IO	SPI Chip Select 1	Y25
SPI6_CS2	IO	SPI Chip Select 2	U26
SPI6_CS3	IO	SPI Chip Select 3	AA28
SPI6_D0	IO	SPI Data 0	AB26
SPI6_D1	IO	SPI Data 1	R28

表 6-46. MCSPI7 Signal Descriptions

SIGNAL NAME [1]	PIN TYPE [2]	DESCRIPTION [3]	ALZ PIN [4]
SPI7_CLK	IO	SPI Clock	AC28
SPI7_CS0	IO	SPI Chip Select 0	Y26
SPI7_CS1	IO	SPI Chip Select 1	Y27
SPI7_CS2	IO	SPI Chip Select 2	AA27
SPI7_CS3	IO	SPI Chip Select 3	V23
SPI7_D0	IO	SPI Data 0	U28

**表 6-46. MCSPI7 Signal Descriptions (continued)**

SIGNAL NAME [1]	PIN TYPE [2]	DESCRIPTION [3]	ALZ PIN [4]
SPI7_D1	IO	SPI Data 1	T27

### 6.3.7.2 MCU Domain

**表 6-47. MCU\_MCSPi0 Signal Descriptions**

SIGNAL NAME [1]	PIN TYPE [2]	DESCRIPTION [3]	ALZ PIN [4]
MCU_SPI0_CLK	IO	SPI Clock	B27
MCU_SPI0_CS0	IO	SPI Chip Select 0	B26
MCU_SPI0_CS1	IO	SPI Chip Select 1	A20, C25
MCU_SPI0_CS2	IO	SPI Chip Select 2	B24, C21
MCU_SPI0_CS3	IO	SPI Chip Select 3	C23
MCU_SPI0_D0	IO	SPI Data 0	D24
MCU_SPI0_D1	IO	SPI Data 1	B25

**表 6-48. MCU\_MCSPi1 Signal Descriptions**

SIGNAL NAME [1]	PIN TYPE [2]	DESCRIPTION [3]	ALZ PIN [4]
MCU_SPI1_CLK	IO	SPI Clock	D26
MCU_SPI1_CS0	IO	SPI Chip Select 0	C27
MCU_SPI1_CS1	IO	SPI Chip Select 1	C24, G20
MCU_SPI1_CS2	IO	SPI Chip Select 2	C20, D25
MCU_SPI1_CS3	IO	SPI Chip Select 3	F26
MCU_SPI1_D0	IO	SPI Data 0	E24
MCU_SPI1_D1	IO	SPI Data 1	C28

### 6.3.8 UART

#### 6.3.8.1 MAIN Domain

**表 6-49. UART0 Signal Descriptions**

SIGNAL NAME [1]	PIN TYPE [2]	DESCRIPTION [3]	ALZ PIN [4]
UART0_CTSn	I	UART Clear to Send (active low)	R22, V27
UART0_DCDn	I	UART Data Carrier Detect (active low)	AC24
UART0_DSRn	I	UART Data Set Ready (active low)	AE28
UART0_DTRn	O	UART Data Terminal Ready (active low)	AF28
UART0_RIn	I	UART Ring Indicator	AD25
UART0_RTSn	O	UART Request to Send (active low)	AF26, P23, W27
UART0_RXD	I	UART Receive Data	V28
UART0_TXD	O	UART Transmit Data	T28

**表 6-50. UART1 Signal Descriptions**

SIGNAL NAME [1]	PIN TYPE [2]	DESCRIPTION [3]	ALZ PIN [4]
UART1_CTSn	I	UART Clear to Send (active low)	AA26, AH27
UART1_RTSn	O	UART Request to Send (active low)	AC27, AG26
UART1_RXD	I	UART Receive Data	Y27
UART1_TXD	O	UART Transmit Data	AA27

表 6-51. UART2 Signal Descriptions

SIGNAL NAME [1]	PIN TYPE [2]	DESCRIPTION [3]	ALZ PIN [4]
UART2_CTSn	I	UART Clear to Send (active low)	AB26
UART2_RTSn	O	UART Request to Send (active low)	AD28
UART2_RXD	I	UART Receive Data	AG26, P24, W28
UART2_TXD	O	UART Transmit Data	AH26, M23, U28

表 6-52. UART3 Signal Descriptions

SIGNAL NAME [1]	PIN TYPE [2]	DESCRIPTION [3]	ALZ PIN [4]
UART3_CTSn	I	UART Clear to Send (active low)	T27
UART3_RTSn	O	UART Request to Send (active low)	R27
UART3_RXD	I	UART Receive Data	AB26, AE25, R28
UART3_TXD	O	UART Transmit Data	AD28, AG25, Y25

表 6-53. UART4 Signal Descriptions

SIGNAL NAME [1]	PIN TYPE [2]	DESCRIPTION [3]	ALZ PIN [4]
UART4_CTSn	I	UART Clear to Send (active low)	AA25, AB27, P23
UART4_RTSn	O	UART Request to Send (active low)	AA24, N24, V25
UART4_RXD	I	UART Receive Data	AC28, P24, T25, U25
UART4_TXD	O	UART Transmit Data	AE28, M23, W24, Y26

表 6-54. UART5 Signal Descriptions

SIGNAL NAME [1]	PIN TYPE [2]	DESCRIPTION [3]	ALZ PIN [4]
UART5_CTSn	I	UART Clear to Send (active low)	P24, T23
UART5_RTSn	O	UART Request to Send (active low)	M23, U24
UART5_RXD	I	UART Receive Data	AC24, R22, T24
UART5_TXD	O	UART Transmit Data	AB25, R24, W25

表 6-55. UART6 Signal Descriptions

SIGNAL NAME [1]	PIN TYPE [2]	DESCRIPTION [3]	ALZ PIN [4]
UART6_CTSn	I	UART Clear to Send (active low)	W28
UART6_RTSn	O	UART Request to Send (active low)	U28
UART6_RXD	I	UART Receive Data	AA26, AD25, T26
UART6_TXD	O	UART Transmit Data	AC27, AF28, V26

表 6-56. UART7 Signal Descriptions

SIGNAL NAME [1]	PIN TYPE [2]	DESCRIPTION [3]	ALZ PIN [4]
UART7_CTSn	I	UART Clear to Send (active low)	P24
UART7_RTSn	O	UART Request to Send (active low)	M23
UART7_RXD	I	UART Receive Data	R22, T23, V23
UART7_TXD	O	UART Transmit Data	AD24, R24, U24

表 6-57. UART8 Signal Descriptions

SIGNAL NAME [1]	PIN TYPE [2]	DESCRIPTION [3]	ALZ PIN [4]
UART8_CTSn	I	UART Clear to Send (active low)	AC28
UART8_RTSn	O	UART Request to Send (active low)	Y26
UART8_RXD	I	UART Receive Data	AB28, AC25, AF26, P23

**表 6-57. UART8 Signal Descriptions (continued)**

SIGNAL NAME [1]	PIN TYPE [2]	DESCRIPTION [3]	ALZ PIN [4]
UART8_TXD	O	UART Transmit Data	AD26, AH27, N24, U27

**表 6-58. UART9 Signal Descriptions**

SIGNAL NAME [1]	PIN TYPE [2]	DESCRIPTION [3]	ALZ PIN [4]
UART9_CTSn	I	UART Clear to Send (active low)	AB27, T26
UART9_RTSn	O	UART Request to Send (active low)	AA24, AD24
UART9_RXD	I	UART Receive Data	V27, Y24
UART9_TXD	O	UART Transmit Data	W23, W27

### 6.3.8.2 MCU Domain

**表 6-59. MCU\_UART0 Signal Descriptions**

SIGNAL NAME [1]	PIN TYPE [2]	DESCRIPTION [3]	ALZ PIN [4]
MCU_UART0_CTSn	I	UART Clear to Send (active low)	A20, B24
MCU_UART0_RTSn	O	UART Request to Send (active low)	C21, D25
MCU_UART0_RXD	I	UART Receive Data	C24, F25, G20
MCU_UART0_TXD	O	UART Transmit Data	C20, C25, F27

### 6.3.8.3 WKUP Domain

**表 6-60. WKUP\_UART0 Signal Descriptions**

SIGNAL NAME [1]	PIN TYPE [2]	DESCRIPTION [3]	ALZ PIN [4]
WKUP_UART0_CTSn	I	UART Clear to Send (active low)	E25
WKUP_UART0_RTSn	O	UART Request to Send (active low)	F28
WKUP_UART0_RXD	I	UART Receive Data	D28
WKUP_UART0_TXD	O	UART Transmit Data	D27

## 6.3.9 MDIO

### 6.3.9.1 MAIN Domain

**表 6-61. MDIO0 Signal Descriptions**

SIGNAL NAME [1]	PIN TYPE [2]	DESCRIPTION [3]	ALZ PIN [4]
MDIO0_MDC	O	MDIO Clock	T28
MDIO0_MDIO	IO	MDIO Data	V28

### 6.3.9.2 MCU Domain

**表 6-62. MCU\_MDIO0 Signal Descriptions**

SIGNAL NAME [1]	PIN TYPE [2]	DESCRIPTION [3]	ALZ PIN [4]
MCU_MDIO0_MDC	O	MDIO Clock	A21
MCU_MDIO0_MDIO	IO	MDIO Data	A22

## 6.3.10 CPSW2G

### 6.3.10.1 MAIN Domain

**表 6-63. CPSW2G0 Signal Descriptions**

SIGNAL NAME [1]	PIN TYPE [2]	DESCRIPTION [3]	ALZ PIN [4]
CLKOUT	IO	RMII Clock Output	U24
RGMII1_RXC	I	RGMII Receive Clock	AD26

表 6-63. CPSW2G0 Signal Descriptions (continued)

SIGNAL NAME [1]	PIN TYPE [2]	DESCRIPTION [3]	ALZ PIN [4]
RGMII1_RX_CTL	I	RGMII Receive Control	AC25
RGMII1_TXC	O	RGMII Transmit Clock	U25
RGMII1_TX_CTL	O	RGMII Transmit Control	T24
RGMII1_RD0	I	RGMII Receive Data 0	AA24
RGMII1_RD1	I	RGMII Receive Data 1	AB25
RGMII1_RD2	I	RGMII Receive Data 2	T23
RGMII1_RD3	I	RGMII Receive Data 3	U24
RGMII1_TD0	O	RGMII Transmit Data 0	T25
RGMII1_TD1	O	RGMII Transmit Data 1	W24
RGMII1_TD2	O	RGMII Transmit Data 2	AA25
RGMII1_TD3	O	RGMII Transmit Data 3	V25
RMII1_CRS_DV	I	RMII Carrier Sense / Data Valid	V25
RMII1_RX_ER	I	RMII Receive Data Error	T24
RMII1_TX_EN	O	RMII Transmit Enable	AC25
RMII1_RXD0	I	RMII Receive Data 0	W24
RMII1_RXD1	I	RMII Receive Data 1	AA25
RMII1_TXD0	O	RMII Transmit Data 0	AB25
RMII1_TXD1	O	RMII Transmit Data 1	AD26
RMII_REF_CLK	I	RMII Reference Clock	T23

## 6.3.10.2 MCU Domain

表 6-64. MCU\_CPSW2G0 Signal Descriptions

SIGNAL NAME [1]	PIN TYPE [2]	DESCRIPTION [3]	ALZ PIN [4]
MCU_RGMII1_RXC	I	RGMII Receive Clock	D22
MCU_RGMII1_RX_CTL	I	RGMII Receive Control	E23
MCU_RGMII1_TXC	O	RGMII Transmit Clock	F21
MCU_RGMII1_TX_CTL	O	RGMII Transmit Control	F22
MCU_RGMII1_RD0	I	RGMII Receive Data 0	B22
MCU_RGMII1_RD1	I	RGMII Receive Data 1	B21
MCU_RGMII1_RD2	I	RGMII Receive Data 2	C22
MCU_RGMII1_RD3	I	RGMII Receive Data 3	D23
MCU_RGMII1_TD0	O	RGMII Transmit Data 0	F23
MCU_RGMII1_TD1	O	RGMII Transmit Data 1	G22
MCU_RGMII1_TD2	O	RGMII Transmit Data 2	E21
MCU_RGMII1_TD3	O	RGMII Transmit Data 3	E22
MCU_RMII1_CRS_DV	I	RMII Carrier Sense / Data Valid	F22
MCU_RMII1_REF_CLK	I	RMII Reference Clock	D22
MCU_RMII1_RX_ER	I	RMII Receive Data Error	E23
MCU_RMII1_TX_EN	O	RMII Transmit Enable	F21
MCU_RMII1_RXD0	I	RMII Receive Data 0	B22
MCU_RMII1_RXD1	I	RMII Receive Data 1	B21
MCU_RMII1_TXD0	O	RMII Transmit Data 0	F23
MCU_RMII1_TXD1	O	RMII Transmit Data 1	G22

### 6.3.11 ECAP

#### 6.3.11.1 MAIN Domain

**表 6-65. ECAP0 Signal Descriptions**

SIGNAL NAME [1]	PIN TYPE [2]	DESCRIPTION [3]	ALZ PIN [4]
ECAP0_IN_APWM_OUT	IO	Enhanced Capture (ECAP) Input or Auxiliary PWM (APWM) Output	AB26, P24

**表 6-66. ECAP1 Signal Descriptions**

SIGNAL NAME [1]	PIN TYPE [2]	DESCRIPTION [3]	ALZ PIN [4]
ECAP1_IN_APWM_OUT	IO	Enhanced Capture (ECAP) Input or Auxiliary PWM (APWM) Output	AE25, M23

**表 6-67. ECAP2 Signal Descriptions**

SIGNAL NAME [1]	PIN TYPE [2]	DESCRIPTION [3]	ALZ PIN [4]
ECAP2_IN_APWM_OUT	IO	Enhanced Capture (ECAP) Input or Auxiliary PWM (APWM) Output	AG25

### 6.3.12 EQEP

#### 6.3.12.1 MAIN Domain

**表 6-68. EQEP0 Signal Descriptions**

SIGNAL NAME [1]	PIN TYPE [2]	DESCRIPTION [3]	ALZ PIN [4]
EQEP0_A	I	EQEP Quadrature Input A	U24
EQEP0_B	I	EQEP Quadrature Input B	AC25
EQEP0_I	IO	EQEP Index	V28
EQEP0_S	IO	EQEP Strobe	AA24

**表 6-69. EQEP1 Signal Descriptions**

SIGNAL NAME [1]	PIN TYPE [2]	DESCRIPTION [3]	ALZ PIN [4]
EQEP1_A	I	EQEP Quadrature Input A	AD26
EQEP1_B	I	EQEP Quadrature Input B	U25
EQEP1_I	IO	EQEP Index	T26
EQEP1_S	IO	EQEP Strobe	T28

**表 6-70. EQEP2 Signal Descriptions**

SIGNAL NAME [1]	PIN TYPE [2]	DESCRIPTION [3]	ALZ PIN [4]
EQEP2_A	I	EQEP Quadrature Input A	AB27
EQEP2_B	I	EQEP Quadrature Input B	W27
EQEP2_I	IO	EQEP Index	AA26
EQEP2_S	IO	EQEP Strobe	Y27

### 6.3.13 EPWM

#### 6.3.13.1 MAIN Domain

**表 6-71. EPWM Signal Descriptions**

SIGNAL NAME [1]	PIN TYPE [2]	DESCRIPTION [3]	ALZ PIN [4]
EHRPWM_SOCA	O	EHRPWM Start of Conversion A	AA27
EHRPWM_SOCB	O	EHRPWM Start of Conversion B	AB25
EHRPWM_TZn_IN0	I	EHRPWM Trip Zone Input 0 (active low)	T27

表 6-71. EPWM Signal Descriptions (continued)

SIGNAL NAME [1]	PIN TYPE [2]	DESCRIPTION [3]	ALZ PIN [4]
EHRPWM_TZn_IN1	I	EHRPWM Trip Zone Input 1 (active low)	V27
EHRPWM_TZn_IN2	I	EHRPWM Trip Zone Input 2 (active low)	AB28
EHRPWM_TZn_IN3	I	EHRPWM Trip Zone Input 3 (active low)	W24
EHRPWM_TZn_IN4	I	EHRPWM Trip Zone Input 4 (active low)	AD27
EHRPWM_TZn_IN5	I	EHRPWM Trip Zone Input 5 (active low)	V26

表 6-72. EPWM0 Signal Descriptions

SIGNAL NAME [1]	PIN TYPE [2]	DESCRIPTION [3]	ALZ PIN [4]
EHRPWM0_A	IO	EHRPWM Output A	AE27, R24, U28
EHRPWM0_B	IO	EHRPWM Output B	R22, W28
EHRPWM0_SYNCI	I	Sync Input to EHRPWM module from an external pin	R27
EHRPWM0_SYNCO	O	Sync Output to EHRPWM module to an external pin	Y26

表 6-73. EPWM1 Signal Descriptions

SIGNAL NAME [1]	PIN TYPE [2]	DESCRIPTION [3]	ALZ PIN [4]
EHRPWM1_A	IO	EHRPWM Output A	AC27, AF26, M23
EHRPWM1_B	IO	EHRPWM Output B	P24, R28

表 6-74. EPWM2 Signal Descriptions

SIGNAL NAME [1]	PIN TYPE [2]	DESCRIPTION [3]	ALZ PIN [4]
EHRPWM2_A	IO	EHRPWM Output A	AC28, AH27, N24
EHRPWM2_B	IO	EHRPWM Output B	P23, U27

表 6-75. EPWM3 Signal Descriptions

SIGNAL NAME [1]	PIN TYPE [2]	DESCRIPTION [3]	ALZ PIN [4]
EHRPWM3_A	IO	EHRPWM Output A	AG26, R22, T25
EHRPWM3_B	IO	EHRPWM Output B	T24
EHRPWM3_SYNCI	I	Sync Input to EHRPWM module from an external pin	V25
EHRPWM3_SYNCO	O	Sync Output to EHRPWM module to an external pin	AA25

表 6-76. EPWM4 Signal Descriptions

SIGNAL NAME [1]	PIN TYPE [2]	DESCRIPTION [3]	ALZ PIN [4]
EHRPWM4_A	IO	EHRPWM Output A	AH26, P24, T23
EHRPWM4_B	IO	EHRPWM Output B	Y25

表 6-77. EPWM5 Signal Descriptions

SIGNAL NAME [1]	PIN TYPE [2]	DESCRIPTION [3]	ALZ PIN [4]
EHRPWM5_A	IO	EHRPWM Output A	AA28, P23
EHRPWM5_B	IO	EHRPWM Output B	U26

## 6.3.14 USB

### 6.3.14.1 MAIN Domain

表 6-78. USB0 Signal Descriptions

SIGNAL NAME [1]	PIN TYPE [2]	DESCRIPTION [3]	ALZ PIN [4]
USB0_DM	IO	USB 2.0 Differential Data (negative)	AG2

**表 6-78. USB0 Signal Descriptions (continued)**

SIGNAL NAME [1]	PIN TYPE [2]	DESCRIPTION [3]	ALZ PIN [4]
USB0_DP	IO	USB 2.0 Differential Data (positive)	AH2
USB0_DRVVBUS	O	USB VBUS Control Output (active high)	AG25, T25, V23
USB0_ID	A	USB 2.0 Dual-Role Device Role Select	AC9
USB0_RCALIB <sup>(1)</sup>	A	Pin to connect to calibration resistor	AA6
USB0_VBUS <sup>(2)</sup>	A	USB Level-shifted VBUS Detector	AA8
USB0_SSRX1N	I	SERDES_USB Differential Receive Data (negative)	AF6, AF9
USB0_SSRX1P	I	SERDES_USB Differential Receive Data (positive)	AF10, AF7
USB0_SSRX2N	I	SERDES_USB Differential Receive Data (negative)	AE5, AE8
USB0_SSRX2P	I	SERDES_USB Differential Receive Data (positive)	AE6, AE9
USB0_SSTX1N	O	SERDES_USB Differential Transmit Data (negative)	AG5, AH7
USB0_SSTX1P	O	SERDES_USB Differential Transmit Data (positive)	AG6, AH8
USB0_SSTX2N	O	SERDES_USB Differential Transmit Data (negative)	AD7, AG8
USB0_SSTX2P	O	SERDES_USB Differential Transmit Data (positive)	AD8, AG9

(1) An external 500 Ω ±1% resistor must be connected between this pin and VSS, even when the pin is unused

(2) An external resistor divider is required to limit the voltage applied to the device pin. For more information, see [Optional text USB VBUS Design Guidelines](#).

### 6.3.15 Display Port

#### 6.3.15.1 MAIN Domain

**表 6-79. DP0 Signal Descriptions**

SIGNAL NAME [1]	PIN TYPE [2]	DESCRIPTION [3]	ALZ PIN [4]
DP0_AUXN	IO	Display Port Differential Auxiliary Data (negative)	AG11
DP0_AUXP	IO	Display Port Differential Auxiliary Data (positive)	AF11
DP0_HPD	I	Display Port Hot Plug Detection	AA24
DP0_TXN0	O	Display Port Differential Transmit (negative)	AG5, AH7
DP0_TXN1	O	Display Port Differential Transmit (negative)	AD7, AG8
DP0_TXN2	O	Display Port Differential Transmit (negative)	AG5
DP0_TXN3	O	Display Port Differential Transmit (negative)	AD7
DP0_TXP0	O	Display Port Differential Transmit (positive)	AG6, AH8
DP0_TXP1	O	Display Port Differential Transmit (positive)	AD8, AG9
DP0_TXP2	O	Display Port Differential Transmit (positive)	AG6
DP0_TXP3	O	Display Port Differential Transmit (positive)	AD8

### 6.3.16 Hyperlink

#### 6.3.16.1 MAIN Domain

**表 6-80. Hyperlink Signal Descriptions**

SIGNAL NAME [1]	PIN TYPE [2]	DESCRIPTION [3]	ALZ PIN [4]
HYP_RXN0	I	Hyperlink RX (negative)	AF9
HYP_RXN1	I	Hyperlink RX (negative)	AE8
HYP_RXN2	I	Hyperlink RX (negative)	AF6
HYP_RXN3	I	Hyperlink RX (negative)	AE5
HYP_RXP0	I	Hyperlink RX (positive)	AF10
HYP_RXP1	I	Hyperlink RX (positive)	AE9
HYP_RXP2	I	Hyperlink RX (positive)	AF7
HYP_RXP3	I	Hyperlink RX (positive)	AE6

表 6-80. Hyperlink Signal Descriptions (continued)

SIGNAL NAME [1]	PIN TYPE [2]	DESCRIPTION [3]	ALZ PIN [4]
HYP_TXN0	O	Hyperlink TX0 (negative)	AH7
HYP_TXN1	O	Hyperlink TX0 (negative)	AG8
HYP_TXN2	O	Hyperlink TX0 (negative)	AG5
HYP_TXN3	O	Hyperlink TX0 (negative)	AD7
HYP_TXP0	O	Hyperlink TX0 (positive)	AH8
HYP_TXP1	O	Hyperlink TX0 (positive)	AG9
HYP_TXP2	O	Hyperlink TX0 (positive)	AG6
HYP_TXP3	O	Hyperlink TX0 (positive)	AD8

表 6-81. Hyperlink0 Signal Descriptions

SIGNAL NAME [1]	PIN TYPE [2]	DESCRIPTION [3]	ALZ PIN [4]
HYP0_RXFLCLK	O	Hyperlink Flow Management Receive Clock	AB28
HYP0_RXFLDAT	O	Hyperlink Flow Management Receive Data	U27
HYP0_RXPMCLK	I	Hyperlink Power Management Receive Clock	AA26
HYP0_RXPMDAT	I	Hyperlink Power Management Receive Data	AC27
HYP0_TXFLCLK	I	Hyperlink Flow Management Transmit Clock	AC28
HYP0_TXFLDAT	I	Hyperlink Flow Management Transmit Data	Y26
HYP0_TXPMCLK	O	Hyperlink Power Management Transmit Clock	Y27
HYP0_TXPMDAT	O	Hyperlink Power Management Transmit Data	AA27

表 6-82. Hyperlink1 Signal Descriptions

SIGNAL NAME [1]	PIN TYPE [2]	DESCRIPTION [3]	ALZ PIN [4]
HYP1_RXFLCLK	O	Hyperlink Flow Management Receive Clock	AB27
HYP1_RXFLDAT	O	Hyperlink Flow Management Receive Data	T26
HYP1_RXPMCLK	I	Hyperlink Power Management Receive Clock	V27
HYP1_RXPMDAT	I	Hyperlink Power Management Receive Data	W27
HYP1_TXFLCLK	I	Hyperlink Flow Management Transmit Clock	AB26
HYP1_TXFLDAT	I	Hyperlink Flow Management Transmit Data	AD28
HYP1_TXPMCLK	O	Hyperlink Power Management Transmit Clock	V26
HYP1_TXPMDAT	O	Hyperlink Power Management Transmit Data	U26

### 6.3.17 PCIE

#### 6.3.17.1 MAIN Domain

表 6-83. PCIE Signal Descriptions

SIGNAL NAME [1]	PIN TYPE [2]	DESCRIPTION [3]	ALZ PIN [4]
PCIE1_CLKREQn	IO	PCIE Clock Request Signal	AE25, R22
PCIE1_RXN0	I	SERDES_PCIE Differential Receive Data (negative)	AF9
PCIE1_RXN1	I	SERDES_PCIE Differential Receive Data (negative)	AE8
PCIE1_RXN2	I	SERDES_PCIE Differential Receive Data (negative)	AF6
PCIE1_RXN3	I	SERDES_PCIE Differential Receive Data (negative)	AE5
PCIE1_RXP0	I	SERDES_PCIE Differential Receive Data (positive)	AF10
PCIE1_RXP1	I	SERDES_PCIE Differential Receive Data (positive)	AE9
PCIE1_RXP2	I	SERDES_PCIE Differential Receive Data (positive)	AF7
PCIE1_RXP3	I	SERDES_PCIE Differential Receive Data (positive)	AE6
PCIE1_TXN0	O	SERDES_PCIE Differential Transmit Data (negative)	AH7

表 6-83. PCIe Signal Descriptions (continued)

SIGNAL NAME [1]	PIN TYPE [2]	DESCRIPTION [3]	ALZ PIN [4]
PCIE1_TXN1	O	SERDES_PCIE Differential Transmit Data (negative)	AG8
PCIE1_TXN2	O	SERDES_PCIE Differential Transmit Data (negative)	AG5
PCIE1_TXN3	O	SERDES_PCIE Differential Transmit Data (negative)	AD7
PCIE1_TXP0	O	SERDES_PCIE Differential Transmit Data (positive)	AH8
PCIE1_TXP1	O	SERDES_PCIE Differential Transmit Data (positive)	AG9
PCIE1_TXP2	O	SERDES_PCIE Differential Transmit Data (positive)	AG6
PCIE1_TXP3	O	SERDES_PCIE Differential Transmit Data (positive)	AD8
PCIE_REFCLK1_N_OUT	O	SERDES_PCIE Reference Clock Out Negative	AH10
PCIE_REFCLK1_P_OUT	O	SERDES_PCIE Reference Clock Out Positive	AH11

### 6.3.18 SERDES

#### 6.3.18.1 MAIN Domain

表 6-84. SERDES0 Signal Descriptions

SIGNAL NAME [1]	PIN TYPE [2]	DESCRIPTION [3]	ALZ PIN [4]
SERDES0_REFCLK_N	IO	Serdes Reference Clock Input/Output (negative)	AH4
SERDES0_REFCLK_P	IO	Serdes Reference Clock Input/Output (positive)	AH5
SERDES0_REXT <sup>(1)</sup>	I	External Calibration Resistor	AC10

(1) An external 3.01 kΩ ±1% resistor must be connected between this pin and VSS. No external voltage should be applied to this pin.

### 6.3.19 DSI

#### 6.3.19.1 MAIN Domain

表 6-85. DSI0 Signal Descriptions

SIGNAL NAME [1]	PIN TYPE [2]	DESCRIPTION [3]	ALZ PIN [4]
DSI0_TXCLKN	O	DSI Transmit clock (negative)	AH13
DSI0_TXCLKP	O	DSI Transmit clock (positive)	AH14
DSI0_TXRCALIB <sup>(1)</sup>	A	DSI Transmit Calibration Resistor	AC13
DSI0_TXN0	IO	DSI Transmit (negative)	AG12
DSI0_TXN1	O	DSI Transmit (negative)	AF13
DSI0_TXN2	O	DSI Transmit (negative)	AE12
DSI0_TXN3	O	DSI Transmit (negative)	AD13
DSI0_TXP0	IO	DSI Transmit (positive)	AG13
DSI0_TXP1	O	DSI Transmit (positive)	AF14
DSI0_TXP2	O	DSI Transmit (positive)	AE13
DSI0_TXP3	O	DSI Transmit (positive)	AD14

(1) An external 500 Ω ±1% resistor must be connected between this pin and VSS, even when the pin is unused.

表 6-86. DSI1 Signal Descriptions

SIGNAL NAME [1]	PIN TYPE [2]	DESCRIPTION [3]	ALZ PIN [4]
DSI1_TXCLKN	O	DSI Transmit clock (negative)	AH16
DSI1_TXCLKP	O	DSI Transmit clock (positive)	AH17
DSI1_TXRCALIB <sup>(1)</sup>	A	DSI Transmit Calibration Resistor	AC15
DSI1_TXN0	IO	DSI Transmit (negative)	AG15
DSI1_TXN1	O	DSI Transmit (negative)	AF16
DSI1_TXN2	O	DSI Transmit (negative)	AE15
DSI1_TXN3	O	DSI Transmit (negative)	AD16

表 6-86. DSI1 Signal Descriptions (continued)

SIGNAL NAME [1]	PIN TYPE [2]	DESCRIPTION [3]	ALZ PIN [4]
DSI1_TXP0	IO	DSI Transmit (positive)	AG16
DSI1_TXP1	O	DSI Transmit (positive)	AF17
DSI1_TXP2	O	DSI Transmit (positive)	AE16
DSI1_TXP3	O	DSI Transmit (positive)	AD17

(1) An external 500  $\Omega$   $\pm$ 1% resistor must be connected between this pin and VSS, even when the pin is unused.

### 6.3.20 CSI

#### 6.3.20.1 MAIN Domain

表 6-87. CSI0 Signal Descriptions

SIGNAL NAME [1]	PIN TYPE [2]	DESCRIPTION [3]	ALZ PIN [4]
CSI0_RXCLKN	I	CSI Differential Receive Clock Input (negative)	AH19
CSI0_RXCLKP	I	CSI Differential Receive Clock Input (positive)	AH20
CSI0_RXRCALIB <sup>(1)</sup>	A	CSI Pin connected to external resistor for on-chip resistor calibration	AC18
CSI0_TXCLKN	O	CSI Differential Transmit Clock Output (negative)	AH13
CSI0_TXCLKP	O	CSI Differential Transmit Clock Output (positive)	AH14
CSI0_RXN0	I	CSI Differential Receive Input (negative)	AG18
CSI0_RXN1	I	CSI Differential Receive Input (negative)	AF19
CSI0_RXN2	I	CSI Differential Receive Input (negative)	AE18
CSI0_RXN3	I	CSI Differential Receive Input (negative)	AD19
CSI0_RXP0	I	CSI Differential Receive Input (positive)	AG19
CSI0_RXP1	I	CSI Differential Receive Input (positive)	AF20
CSI0_RXP2	I	CSI Differential Receive Input (positive)	AE19
CSI0_RXP3	I	CSI Differential Receive Input (positive)	AD20
CSI0_TXN0	O	CSI Differential Transmit Output (negative)	AG12
CSI0_TXN1	O	CSI Differential Transmit Output (negative)	AF13
CSI0_TXN2	O	CSI Differential Transmit Output (negative)	AE12
CSI0_TXN3	O	CSI Differential Transmit Output (negative)	AD13
CSI0_TXP0	O	CSI Differential Transmit Output (positive)	AG13
CSI0_TXP1	O	CSI Differential Transmit Output (positive)	AF14
CSI0_TXP2	O	CSI Differential Transmit Output (positive)	AE13
CSI0_TXP3	O	CSI Differential Transmit Output (positive)	AD14

(1) An external 500  $\Omega$   $\pm$ 1% resistor must be connected between this pin and VSS, even when the pin is unused.

表 6-88. CSI1 Signal Descriptions

SIGNAL NAME [1]	PIN TYPE [2]	DESCRIPTION [3]	ALZ PIN [4]
CSI1_RXCLKN	I	CSI Differential Receive Clock Input (negative)	AH22
CSI1_RXCLKP	I	CSI Differential Receive Clock Input (positive)	AH23
CSI1_RXRCALIB <sup>(1)</sup>	A	CSI pin connected to external resistor for on-chip resistor calibration	AC21
CSI1_TXCLKN	O	CSI Differential Transmit Clock Output (negative)	AH16
CSI1_TXCLKP	O	CSI Differential Transmit Clock Output (positive)	AH17
CSI1_RXN0	I	CSI Differential Receive Input (negative)	AG21
CSI1_RXN1	I	CSI Differential Receive Input (negative)	AF22
CSI1_RXN2	I	CSI Differential Receive Input (negative)	AE21
CSI1_RXN3	I	CSI Differential Receive Input (negative)	AD22

**表 6-88. CSI1 Signal Descriptions (continued)**

SIGNAL NAME [1]	PIN TYPE [2]	DESCRIPTION [3]	ALZ PIN [4]
CSI1_RXP0	I	CSI Differential Receive Input (positive)	AG22
CSI1_RXP1	I	CSI Differential Receive Input (positive)	AF23
CSI1_RXP2	I	CSI Differential Receive Input (positive)	AE22
CSI1_RXP3	I	CSI Differential Receive Input (positive)	AD23
CSI1_TXN0	O	CSI Differential Transmit Output (negative)	AG15
CSI1_TXN1	O	CSI Differential Transmit Output (negative)	AF16
CSI1_TXN2	O	CSI Differential Transmit Output (negative)	AE15
CSI1_TXN3	O	CSI Differential Transmit Output (negative)	AD16
CSI1_TXP0	O	CSI Differential Transmit Output (positive)	AG16
CSI1_TXP1	O	CSI Differential Transmit Output (positive)	AF17
CSI1_TXP2	O	CSI Differential Transmit Output (positive)	AE16
CSI1_TXP3	O	CSI Differential Transmit Output (positive)	AD17

(1) An external 500 Ω ±1% resistor must be connected between this pin and VSS, even when the pin is unused.

### 6.3.21 MCASP

#### 6.3.21.1 MAIN Domain

**表 6-89. MCASP0 Signal Descriptions**

SIGNAL NAME [1]	PIN TYPE [2]	DESCRIPTION [3]	ALZ PIN [4]
MCASP0_ACLKR	IO	MCASP Receive Bit Clock	U24
MCASP0_ACLKX	IO	MCASP Transmit Bit Clock	AB28
MCASP0_AFSR	IO	MCASP Receive Frame Sync	AC25
MCASP0_AFSX	IO	MCASP Transmit Frame Sync	U27
MCASP0_AXR0	IO	MCASP Serial Data (Input/Output)	AC28
MCASP0_AXR1	IO	MCASP Serial Data (Input/Output)	Y26
MCASP0_AXR2	IO	MCASP Serial Data (Input/Output)	AB27
MCASP0_AXR3	IO	MCASP Serial Data (Input/Output)	T27
MCASP0_AXR4	IO	MCASP Serial Data (Input/Output)	U26
MCASP0_AXR5	IO	MCASP Serial Data (Input/Output)	AA28
MCASP0_AXR6	IO	MCASP Serial Data (Input/Output)	AD27
MCASP0_AXR7	IO	MCASP Serial Data (Input/Output)	T25
MCASP0_AXR8	IO	MCASP Serial Data (Input/Output)	W24
MCASP0_AXR9	IO	MCASP Serial Data (Input/Output)	AA25
MCASP0_AXR10	IO	MCASP Serial Data (Input/Output)	V25
MCASP0_AXR11	IO	MCASP Serial Data (Input/Output)	T24
MCASP0_AXR12	IO	MCASP Serial Data (Input/Output)	AB25
MCASP0_AXR13	IO	MCASP Serial Data (Input/Output)	T23
MCASP0_AXR14	IO	MCASP Serial Data (Input/Output)	U24
MCASP0_AXR15	IO	MCASP Serial Data (Input/Output)	AC25

**表 6-90. MCASP1 Signal Descriptions**

SIGNAL NAME [1]	PIN TYPE [2]	DESCRIPTION [3]	ALZ PIN [4]
MCASP1_ACLKR	IO	MCASP Receive Bit Clock	AA28
MCASP1_ACLKX	IO	MCASP Transmit Bit Clock	AA24
MCASP1_AFSR	IO	MCASP Receive Frame Sync	AD27
MCASP1_AFSX	IO	MCASP Transmit Frame Sync	V28

表 6-90. MCASP1 Signal Descriptions (continued)

SIGNAL NAME [1]	PIN TYPE [2]	DESCRIPTION [3]	ALZ PIN [4]
MCASP1_AXR0	IO	MCASP Serial Data (Input/Output)	T28
MCASP1_AXR1	IO	MCASP Serial Data (Input/Output)	V27
MCASP1_AXR2	IO	MCASP Serial Data (Input/Output)	W27
MCASP1_AXR3	IO	MCASP Serial Data (Input/Output)	AD26
MCASP1_AXR4	IO	MCASP Serial Data (Input/Output)	U25

表 6-91. MCASP2 Signal Descriptions

SIGNAL NAME [1]	PIN TYPE [2]	DESCRIPTION [3]	ALZ PIN [4]
MCASP2_ACLKR	IO	MCASP Receive Bit Clock	AB25
MCASP2_ACLKX	IO	MCASP Transmit Bit Clock	Y27
MCASP2_AFSR	IO	MCASP Receive Frame Sync	T23
MCASP2_AFSX	IO	MCASP Transmit Frame Sync	AA27
MCASP2_AXR0	IO	MCASP Serial Data (Input/Output)	AA26
MCASP2_AXR1	IO	MCASP Serial Data (Input/Output)	AC27
MCASP2_AXR2	IO	MCASP Serial Data (Input/Output)	W28
MCASP2_AXR3	IO	MCASP Serial Data (Input/Output)	R28
MCASP2_AXR4	IO	MCASP Serial Data (Input/Output)	U24

表 6-92. MCASP3 Signal Descriptions

SIGNAL NAME [1]	PIN TYPE [2]	DESCRIPTION [3]	ALZ PIN [4]
MCASP3_ACLKR	IO	MCASP Receive Bit Clock	AE27
MCASP3_ACLKX	IO	MCASP Transmit Bit Clock	AE27
MCASP3_AFSR	IO	MCASP Receive Frame Sync	AF26
MCASP3_AFSX	IO	MCASP Transmit Frame Sync	AF26
MCASP3_AXR0	IO	MCASP Serial Data (Input/Output)	AH27
MCASP3_AXR1	IO	MCASP Serial Data (Input/Output)	AG26
MCASP3_AXR2	IO	MCASP Serial Data (Input/Output)	AH26

表 6-93. MCASP4 Signal Descriptions

SIGNAL NAME [1]	PIN TYPE [2]	DESCRIPTION [3]	ALZ PIN [4]
MCASP4_ACLKR	IO	MCASP Receive Bit Clock	T25
MCASP4_ACLKX	IO	MCASP Transmit Bit Clock	AD28
MCASP4_AFSR	IO	MCASP Receive Frame Sync	W24
MCASP4_AFSX	IO	MCASP Transmit Frame Sync	V26
MCASP4_AXR0	IO	MCASP Serial Data (Input/Output)	AD24
MCASP4_AXR1	IO	MCASP Serial Data (Input/Output)	U28
MCASP4_AXR2	IO	MCASP Serial Data (Input/Output)	AB26
MCASP4_AXR3	IO	MCASP Serial Data (Input/Output)	R27
MCASP4_AXR4	IO	MCASPI Serial Data (Input/Output)	AA25

## 6.3.22 DMTIMER

### 6.3.22.1 MAIN Domain

**表 6-94. DMTIMER Signal Descriptions**

SIGNAL NAME [1]	PIN TYPE [2]	DESCRIPTION [3]	ALZ PIN [4]
TIMER_IO0	IO	Timer Inputs and Outputs (Can be used with any MAIN domain timer instance)	AE25
TIMER_IO1	IO	Timer Inputs and Outputs (Can be used with any MAIN domain timer instance)	AG25
TIMER_IO2	IO	Timer Inputs and Outputs (Can be used with any MAIN domain timer instance)	R22
TIMER_IO3	IO	Timer Inputs and Outputs (Can be used with any MAIN domain timer instance)	R24
TIMER_IO4	IO	Timer Inputs and Outputs (Can be used with any MAIN domain timer instance)	P24
TIMER_IO5	IO	Timer Inputs and Outputs (Can be used with any MAIN domain timer instance)	M23
TIMER_IO6	IO	Timer Inputs and Outputs (Can be used with any MAIN domain timer instance)	P23
TIMER_IO7	IO	Timer Inputs and Outputs (Can be used with any MAIN domain timer instance)	N24

### 6.3.22.2 MCU Domain

**表 6-95. MCU\_DMTIMER Signal Descriptions**

SIGNAL NAME [1]	PIN TYPE [2]	DESCRIPTION [3]	ALZ PIN [4]
MCU_TIMER_IO0	IO	Timer Inputs and Outputs (Can be used with any MCU domain timer instance.)	B25, C21
MCU_TIMER_IO1	IO	Timer Inputs and Outputs (Can be used with any MCU domain timer instance.)	B26, F25
MCU_TIMER_IO2	IO	Timer Inputs and Outputs (Can be used with any MCU domain timer instance.)	E22
MCU_TIMER_IO3	IO	Timer Inputs and Outputs (Can be used with any MCU domain timer instance.)	E21
MCU_TIMER_IO4	IO	Timer Inputs and Outputs (Can be used with any MCU domain timer instance.)	D23
MCU_TIMER_IO5	IO	Timer Inputs and Outputs (Can be used with any MCU domain timer instance.)	C22
MCU_TIMER_IO6	IO	Timer Inputs and Outputs (Can be used with any MCU domain timer instance.)	F24, G27
MCU_TIMER_IO7	IO	Timer Inputs and Outputs (Can be used with any MCU domain timer instance.)	H26, J26
MCU_TIMER_IO8	IO	Timer Inputs and Outputs (Can be used with any MCU domain timer instance.)	B24
MCU_TIMER_IO9	IO	Timer Inputs and Outputs (Can be used with any MCU domain timer instance.)	D25

## 6.3.23 CPTS

### 6.3.23.1 MAIN Domain

**表 6-96. CPTS0 Signal Descriptions**

SIGNAL NAME [1]	PIN TYPE [2]	DESCRIPTION [3]	ALZ PIN [4]
CPTS0_RFT_CLK	I	CPTS Reference Clock	AB26
CPTS0_TS_COMP	O	CPTS Time Stamp Counter Compare	AF26
CPTS0_TS_SYNC	O	CPTS Time Stamp Counter Bit	R24

表 6-96. CPTS0 Signal Descriptions (continued)

SIGNAL NAME [1]	PIN TYPE [2]	DESCRIPTION [3]	ALZ PIN [4]
CPTS0_HW1TSPUSH	I	CPTS Hardware Time Stamp Push 1	AB26
CPTS0_HW2TSPUSH	I	CPTS Hardware Time Stamp Push 2	AD28

### 6.3.23.2 MCU Domain

表 6-97. MCU\_CPTS0 Signal Descriptions

SIGNAL NAME [1]	PIN TYPE [2]	DESCRIPTION [3]	ALZ PIN [4]
MCU_CPTS0_RFT_CLK	I	CPTS Reference Clock	F27, K26
MCU_CPTS0_TS_COMP	O	CPTS Time Stamp Counter Compare	H26
MCU_CPTS0_TS_SYNC	O	CPTS Time Stamp Counter Bit	F24
MCU_CPTS0_HW1TSPUSH	I	CPTS Hardware Time Stamp Push 1	E25
MCU_CPTS0_HW2TSPUSH	I	CPTS Hardware Time Stamp Push 2	F28

### 6.3.24 DSS

#### 6.3.24.1 MAIN Domain

表 6-98. DSS0 Signal Descriptions

SIGNAL NAME [1]	PIN TYPE [2]	DESCRIPTION [3]	ALZ PIN [4]
DSS_FSYNC0	O	Video Output Frame Sync	V26, W25
DSS_FSYNC1	O	Video Output Frame Sync	AC24, AD24
DSS_FSYNC2	O	Video Output Frame Sync	AE28
DSS_FSYNC3	O	Video Output Frame Sync	AF28
VOU0_DE	O	Video Output Data Enable	AA28
VOU0_EXTPCLKIN	I	Video Output External Pixel Clock Input	V26
VOU0_HSYNC	O	Video Output Horizontal Sync	U26
VOU0_PCLK	O	Video Output Pixel Clock Output	Y25
VOU0_VSYNC	O	Video Output Vertical Sync	AD27
VOU0_DATA0	O	Video Output Data 0	R28
VOU0_DATA1	O	Video Output Data 1	R27
VOU0_DATA2	O	Video Output Data 2	T27
VOU0_DATA3	O	Video Output Data 3	U28
VOU0_DATA4	O	Video Output Data 4	W28
VOU0_DATA5	O	Video Output Data 5	AC27
VOU0_DATA6	O	Video Output Data 6	AA26
VOU0_DATA7	O	Video Output Data 7	AA27
VOU0_DATA8	O	Video Output Data 8	Y27
VOU0_DATA9	O	Video Output Data 9	W27
VOU0_DATA10	O	Video Output Data 10	V27
VOU0_DATA11	O	Video Output Data 11	AB27
VOU0_DATA12	O	Video Output Data 12	Y26
VOU0_DATA13	O	Video Output Data 13	AC28
VOU0_DATA14	O	Video Output Data 14	U27
VOU0_DATA15	O	Video Output Data 15	AB28
VOU0_DATA16	O	Video Output Data 16	AD28
VOU0_DATA17	O	Video Output Data 17	T26
VOU0_DATA18	O	Video Output Data 18	R28, V23
VOU0_DATA19	O	Video Output Data 19	AB24, R27

**表 6-98. DSS0 Signal Descriptions (continued)**

SIGNAL NAME [1]	PIN TYPE [2]	DESCRIPTION [3]	ALZ PIN [4]
VOU0_DATA20	O	Video Output Data 20	Y27, Y28
VOU0_DATA21	O	Video Output Data 21	AA23, W27
VOU0_DATA22	O	Video Output Data 22	T26, Y24
VOU0_DATA23	O	Video Output Data 23	AB26, W23
VOU0_VP0_DE	O	Alternative Output Data Enable	AA28
VOU0_VP0_HSYNC	O	Alternative Output Horizontal Sync	U26
VOU0_VP0_VSYNC	O	Alternative Output Vertical Sync	AD27
VOU0_VP2_DE	O	Alternative Output Data Enable	AA28
VOU0_VP2_HSYNC	O	Alternative Output Horizontal Sync	U26
VOU0_VP2_VSYNC	O	Alternative Output Vertical Sync	AD27

### 6.3.25 GPMC

#### 6.3.25.1 MAIN Domain

**表 6-99. GPMC0 Signal Descriptions**

SIGNAL NAME [1]	PIN TYPE [2]	DESCRIPTION [3]	ALZ PIN [4]
GPMC0_ADVn_ALE	O	GPMC Address Valid (active low) or Address Latch Enable	AB27
GPMC0_CLK	IO	GPMC clock	W25
GPMC0_CLKOUT	O	GPMC clock generated for external synchronization	AD27
GPMC0_DIR	O	GPMC Data Bus Signal Direction Control	R28, Y25
GPMC0_OEn_REn	O	GPMC Output Enable (active low) or Read Enable (active low)	U26
GPMC0_WEn	O	GPMC Write Enable (active low)	AD24
GPMC0_WPn	O	GPMC Flash Write Protect (active low)	AB27
GPMC0_A0	OZ	GPMC Address 0 Output. Only used to effectively address 8-bit data non-multiplexed memories	T25
GPMC0_A1	OZ	GPMC Address 1 Output in A/D non-multiplexed mode and Address 17 in A/D multiplexed mode	W24
GPMC0_A2	OZ	GPMC Address 2 Output in A/D non-multiplexed mode and Address 18 in A/D multiplexed mode	AA25
GPMC0_A3	OZ	GPMC Address 3 Output in A/D non-multiplexed mode and Address 19 in A/D multiplexed mode	V25
GPMC0_A4	OZ	GPMC Address 4 Output in A/D non-multiplexed mode and Address 20 in A/D multiplexed mode	T24
GPMC0_A5	OZ	GPMC Address 5 Output in A/D non-multiplexed mode and Address 21 in A/D multiplexed mode	AB25
GPMC0_A6	OZ	GPMC Address 6 Output in A/D non-multiplexed mode and Address 22 in A/D multiplexed mode	T23
GPMC0_A7	OZ	GPMC Address 7 Output in A/D non-multiplexed mode and Address 23 in A/D multiplexed mode	U24
GPMC0_A8	OZ	GPMC Address 8 Output in A/D non-multiplexed mode and Address 24 in A/D multiplexed mode	AC25
GPMC0_A9	OZ	GPMC Address 9 Output in A/D non-multiplexed mode and Address 25 in A/D multiplexed mode	AD26
GPMC0_A10	OZ	GPMC Address 10 Output in A/D non-multiplexed mode and Address 26 in A/D multiplexed mode	U25
GPMC0_A11	OZ	GPMC Address 11 Output in A/D non-multiplexed mode and unused in A/D multiplexed mode	AA24

表 6-99. GPMC0 Signal Descriptions (continued)

SIGNAL NAME [1]	PIN TYPE [2]	DESCRIPTION [3]	ALZ PIN [4]
GPMC0_A12	OZ	GPMC Address 12 Output in A/D non-multiplexed mode and unused in A/D multiplexed mode	V28
GPMC0_A13	OZ	GPMC Address 13 Output in A/D non-multiplexed mode and unused in A/D multiplexed mode	T28
GPMC0_A14	OZ	GPMC Address 14 Output in A/D non-multiplexed mode and unused in A/D multiplexed mode	T25, V23
GPMC0_A15	OZ	GPMC Address 15 Output in A/D non-multiplexed mode and unused in A/D multiplexed mode	AB24
GPMC0_A16	OZ	GPMC Address 16 Output in A/D non-multiplexed mode and unused in A/D multiplexed mode	Y28
GPMC0_A17	OZ	GPMC Address 17 Output in A/D non-multiplexed mode and unused in A/D multiplexed mode	AA23
GPMC0_A18	OZ	GPMC Address 18 Output in A/D non-multiplexed mode and unused in A/D multiplexed mode	Y24
GPMC0_A19	OZ	GPMC Address 19 Output in A/D non-multiplexed mode and unused in A/D multiplexed mode	W23
GPMC0_A20	OZ	GPMC Address 20 Output in A/D non-multiplexed mode and unused in A/D multiplexed mode	AD25
GPMC0_A21	OZ	GPMC Address 21 Output in A/D non-multiplexed mode and unused in A/D multiplexed mode	AF28
GPMC0_A22	OZ	GPMC Address 22 Output in A/D non-multiplexed mode and unused in A/D multiplexed mode	AE28
GPMC0_A23	OZ	GPMC Address 23 Output in A/D non-multiplexed mode and unused in A/D multiplexed mode	AC24
GPMC0_A24	OZ	GPMC Address 24 Output in A/D non-multiplexed mode and unused in A/D multiplexed mode	W25
GPMC0_AD0	IO	GPMC Data 0 Input/Output in A/D non-multiplexed mode and additionally Address 1 Output in A/D multiplexed mode	AB28
GPMC0_AD1	IO	GPMC Data 1 Input/Output in A/D non-multiplexed mode and additionally Address 2 Output in A/D multiplexed mode	U27
GPMC0_AD2	IO	GPMC Data 2 Input/Output in A/D non-multiplexed mode and additionally Address 3 Output in A/D multiplexed mode	AC28
GPMC0_AD3	IO	GPMC Data 3 Input/Output in A/D non-multiplexed mode and additionally Address 4 Output in A/D multiplexed mode	Y26
GPMC0_AD4	IO	GPMC Data 4 Input/Output in A/D non-multiplexed mode and additionally Address 5 Output in A/D multiplexed mode	T26
GPMC0_AD5	IO	GPMC Data 5 Input/Output in A/D non-multiplexed mode and additionally Address 6 Output in A/D multiplexed mode	AB26
GPMC0_AD6	IO	GPMC Data 6 Input/Output in A/D non-multiplexed mode and additionally Address 7 Output in A/D multiplexed mode	AD28
GPMC0_AD7	IO	GPMC Data 7 Input/Output in A/D non-multiplexed mode and additionally Address 8 Output in A/D multiplexed mode	V26
GPMC0_AD8	IO	GPMC Data 8 Input/Output in A/D non-multiplexed mode and additionally Address 9 Output in A/D multiplexed mode	V27

**表 6-99. GPMC0 Signal Descriptions (continued)**

SIGNAL NAME [1]	PIN TYPE [2]	DESCRIPTION [3]	ALZ PIN [4]
GPMC0_AD9	IO	GPMC Data 9 Input/Output in A/D non-multiplexed mode and additionally Address 10 Output in A/D multiplexed mode	W27
GPMC0_AD10	IO	GPMC Data 10 Input/Output in A/D non-multiplexed mode and additionally Address 11 Output in A/D multiplexed mode	Y27
GPMC0_AD11	IO	GPMC Data 11 Input/Output in A/D non-multiplexed mode and additionally Address 12 Output in A/D multiplexed mode	AA27
GPMC0_AD12	IO	GPMC Data 12 Input/Output in A/D non-multiplexed mode and additionally Address 13 Output in A/D multiplexed mode	AA26
GPMC0_AD13	IO	GPMC Data 13 Input/Output in A/D non-multiplexed mode and additionally Address 14 Output in A/D multiplexed mode	AC27
GPMC0_AD14	IO	GPMC Data 14 Input/Output in A/D non-multiplexed mode and additionally Address 15 Output in A/D multiplexed mode	W28
GPMC0_AD15	IO	GPMC Data 15 Input/Output in A/D non-multiplexed mode and additionally Address 16 Output in A/D multiplexed mode	U28
GPMC0_BE0n_CLE	O	GPMC Lower-Byte Enable (active low) or Command Latch Enable	R27
GPMC0_BE1n	O	GPMC Upper-Byte Enable (active low)	T27
GPMC0_CS0	O	GPMC Chip Select 0 (active low)	AA28
GPMC0_CS1	O	GPMC Chip Select 1 (active low)	Y25
GPMC0_CS2	O	GPMC Chip Select 2 (active low)	T25, V23
GPMC0_CS3	O	GPMC Chip Select 3 (active low)	AC24
GPMC0_WAIT0	I	GPMC External Indication of Wait	R28
GPMC0_WAIT1	I	GPMC External Indication of Wait	AB24
GPMC0_WAIT2	I	GPMC External Indication of Wait	AE28
GPMC0_WAIT3	I	GPMC External Indication of Wait	T28

### 6.3.26 MMC

#### 6.3.26.1 MAIN Domain

**表 6-100. MMC0 Signal Descriptions**

SIGNAL NAME [1]	PIN TYPE [2]	DESCRIPTION [3]	ALZ PIN [4]
MMC0_CALPAD <sup>(1)</sup>	A	MMC/SD/SDIO Calibration Resistor	AF1
MMC0_CLK	O	MMC/SD/SDIO Clock	AC6
MMC0_CMD	IO	MMC/SD/SDIO Command	AF2
MMC0_DS	IO	MMC Data Strobe	AE3
MMC0_DAT0	IO	MMC/SD/SDIO Data	AF4
MMC0_DAT1	IO	MMC/SD/SDIO Data	AD3
MMC0_DAT2	IO	MMC/SD/SDIO Data	AD4
MMC0_DAT3	IO	MMC/SD/SDIO Data	AF3
MMC0_DAT4	IO	MMC/SD/SDIO Data	AE2
MMC0_DAT5	IO	MMC/SD/SDIO Data	AG3
MMC0_DAT6	IO	MMC/SD/SDIO Data	AE1

表 6-100. MMC0 Signal Descriptions (continued)

SIGNAL NAME [1]	PIN TYPE [2]	DESCRIPTION [3]	ALZ PIN [4]
MMC0_DAT7	IO	MMC/SD/SDIO Data	AG1

(1) An external 10 kΩ ±1% resistor must be connected between this pin and VSS. No external voltage should be applied to this pin.

表 6-101. MMC1 Signal Descriptions

SIGNAL NAME [1]	PIN TYPE [2]	DESCRIPTION [3]	ALZ PIN [4]
MMC1_CLK (2)	IO	MMC/SD/SDIO Clock	P23
MMC1_CMD	IO	MMC/SD/SDIO Command	N24
MMC1_SDCD (1)	I	SD Card Detect	AE25
MMC1_SDWP	I	SD Write Protect	AG25
MMC1_DAT0	IO	MMC/SD/SDIO Data	M23
MMC1_DAT1	IO	MMC/SD/SDIO Data	P24
MMC1_DAT2	IO	MMC/SD/SDIO Data	R24
MMC1_DAT3	IO	MMC/SD/SDIO Data	R22

- (1) For ROM boot from MMC1 interface to work properly, the MMC1\_SDCD pin should be pulled low externally with a resistor to indicate an SD Card/Memory device is present.
- (2) For MMC1\_CLK signal to work properly, the RXACTIVE bit of the CTRLMMR\_PADCONFIG171 register should be set to 0x1 because of retiming purposes.

### 6.3.27 OSPI

#### 6.3.27.1 MCU Domain

表 6-102. MCU\_OSPI0 Signal Descriptions

SIGNAL NAME [1]	PIN TYPE [2]	DESCRIPTION [3]	ALZ PIN [4]
MCU_OSPI0_CLK	O	OSPI Clock	D19
MCU_OSPI0_DQS	I	OSPI Data Strobe (DQS) or Loopback Clock Input	E18
MCU_OSPI0_ECC_FAIL	I	OSPI ECC Status	B19, F17
MCU_OSPI0_LBCLKO	IO	OSPI Loopback Clock Output	E20
MCU_OSPI0_CSn0	O	OSPI Chip Select 0 (active low)	F15
MCU_OSPI0_CSn1	O	OSPI Chip Select 1 (active low)	G17
MCU_OSPI0_CSn2	O	OSPI Chip Select 2 (active low)	B20, F14
MCU_OSPI0_CSn3	O	OSPI Chip Select 3 (active low)	B19, F17
MCU_OSPI0_D0	IO	OSPI Data 0	C19
MCU_OSPI0_D1	IO	OSPI Data 1	F16
MCU_OSPI0_D2	IO	OSPI Data 2	G15
MCU_OSPI0_D3	IO	OSPI Data 3	F18
MCU_OSPI0_D4	IO	OSPI Data 4	E19
MCU_OSPI0_D5	IO	OSPI Data 5	G19
MCU_OSPI0_D6	IO	OSPI Data 6	F19
MCU_OSPI0_D7	IO	OSPI Data 7	F20
MCU_OSPI0_RESET_OUT0	O	OSPI Reset	B20, F14
MCU_OSPI0_RESET_OUT1	O	OSPI Reset	C21, F17

表 6-103. MCU\_OSPI1 Signal Descriptions

SIGNAL NAME [1]	PIN TYPE [2]	DESCRIPTION [3]	ALZ PIN [4]
MCU_OSPI1_CLK	O	OSPI Clock	A19
MCU_OSPI1_DQS	I	OSPI Data Strobe (DQS) or Loopback Clock Input	B19
MCU_OSPI1_LBCLKO	IO	OSPI Loopback Clock Output	B20

**表 6-103. MCU\_OSPI1 Signal Descriptions (continued)**

SIGNAL NAME [1]	PIN TYPE [2]	DESCRIPTION [3]	ALZ PIN [4]
MCU_OSPI1_CSn0	O	OSPI Chip Select 0 (active low)	D20
MCU_OSPI1_CSn1	O	OSPI Chip Select 1 (active low)	C21
MCU_OSPI1_D0	IO	OSPI Data 0	D21
MCU_OSPI1_D1	IO	OSPI Data 1	G20
MCU_OSPI1_D2	IO	OSPI Data 2	C20
MCU_OSPI1_D3	IO	OSPI Data 3	A20

### 6.3.28 Hyperbus

#### 6.3.28.1 MCU Domain

**表 6-104. MCU\_HYPERBUS0 Signal Descriptions**

SIGNAL NAME [1]	PIN TYPE [2]	DESCRIPTION [3]	ALZ PIN [4]
MCU_HYPERBUS0_CK	O	Hyperbus Differential Clock (positive)	D19
MCU_HYPERBUS0_CKn	O	Hyperbus Differential Clock (negative)	E20
MCU_HYPERBUS0_INTn	I	Hyperbus Interrupt (active low)	B19, F17
MCU_HYPERBUS0_RESETh	O	Hyperbus Reset (active low) Output	G17
MCU_HYPERBUS0_RESEThn	I	Hyperbus Reset Status Indicator (active low) from Hyperbus Memory	B20, F14
MCU_HYPERBUS0_RWDS	IO	Hyperbus Read-Write Data Strobe	E18
MCU_HYPERBUS0_WPn	O	Hyperbus Write Protect (Not in use)	C21, F14, F17
MCU_HYPERBUS0_CSn0	O	Hyperbus Chip Select 0	F15
MCU_HYPERBUS0_CSn1	O	Hyperbus Chip Select 1	C21, F14
MCU_HYPERBUS0_DQ0	IO	Hyperbus Data 0	C19
MCU_HYPERBUS0_DQ1	IO	Hyperbus Data 1	F16
MCU_HYPERBUS0_DQ2	IO	Hyperbus Data 2	G15
MCU_HYPERBUS0_DQ3	IO	Hyperbus Data 3	F18
MCU_HYPERBUS0_DQ4	IO	Hyperbus Data 4	E19
MCU_HYPERBUS0_DQ5	IO	Hyperbus Data 5	G19
MCU_HYPERBUS0_DQ6	IO	Hyperbus Data 6	F19
MCU_HYPERBUS0_DQ7	IO	Hyperbus Data 7	F20

### 6.3.29 Emulation and Debug

#### 6.3.29.1 MAIN Domain

**表 6-105. JTAG Signal Descriptions**

SIGNAL NAME [1]	PIN TYPE [2]	DESCRIPTION [3]	ALZ PIN [4]
EMU0	IO	Emulation Control 0	A27
EMU1	IO	Emulation Control 1	C26
TCK	I	JTAG Test Clock Input	A25
TDI	I	JTAG Test Data Input	AG28
TDO	OZ	JTAG Test Data Output	AE26
TMS	I	JTAG Test Mode Select Input	AG27
TRSTn	I	JTAG Reset	B28

**表 6-106. Trace Signal Descriptions**

SIGNAL NAME [1]	PIN TYPE [2]	DESCRIPTION [3]	ALZ PIN [4]
TRC_CLK	O	Trace Clock	AD28, W25

表 6-106. Trace Signal Descriptions (continued)

SIGNAL NAME [1]	PIN TYPE [2]	DESCRIPTION [3]	ALZ PIN [4]
TRC_CTL	O	Trace Control	AC24, V26
TRC_DATA0	O	Trace Data 0	AD24, AE28
TRC_DATA1	O	Trace Data 1	AB26, AF28
TRC_DATA2	O	Trace Data 2	AD25, T26
TRC_DATA3	O	Trace Data 3	R28, W23
TRC_DATA4	O	Trace Data 4	Y27
TRC_DATA5	O	Trace Data 5	R27
TRC_DATA6	O	Trace Data 6	W27
TRC_DATA7	O	Trace Data 7	T27
TRC_DATA8	O	Trace Data 8	V27
TRC_DATA9	O	Trace Data 9	AA27
TRC_DATA10	O	Trace Data 10	AB27
TRC_DATA11	O	Trace Data 11	W28
TRC_DATA12	O	Trace Data 12	Y26
TRC_DATA13	O	Trace Data 13	AC27
TRC_DATA14	O	Trace Data 14	AC28
TRC_DATA15	O	Trace Data 15	AA26
TRC_DATA16	O	Trace Data 16	U28
TRC_DATA17	O	Trace Data 17	Y25
TRC_DATA18	O	Trace Data 18	U26
TRC_DATA19	O	Trace Data 19	AA28
TRC_DATA20	O	Trace Data 20	AD27
TRC_DATA21	O	Trace Data 21	Y24
TRC_DATA22	O	Trace Data 22	AA23
TRC_DATA23	O	Trace Data 23	Y28
TRC_DATA24	O	Trace Data 24	AB24
TRC_DATA25	O	Trace Data 25	V23

### 6.3.30 System and Miscellaneous

#### 6.3.30.1 Boot Mode configuration

表 6-107. Sysboot Signal Descriptions

SIGNAL NAME [1]	PIN TYPE [2]	DESCRIPTION [3]	ALZ PIN [4]
BOOTMODE00	I	Bootmode Pin 0	C19
BOOTMODE01	I	Bootmode Pin 1	F16
BOOTMODE02	I	Bootmode Pin 2	E19
BOOTMODE03	I	Bootmode Pin 3	G19
BOOTMODE04	I	Bootmode Pin 4	G27
BOOTMODE05	I	Bootmode Pin 5	J26
BOOTMODE06	I	Bootmode Pin 6	G25
BOOTMODE07	I	Bootmode Pin 7	J27
MCU_BOOTMODE00	I	MCU Bootmode Pin 0	B27
MCU_BOOTMODE01	I	MCU Bootmode Pin 1	D24
MCU_BOOTMODE02	I	MCU Bootmode Pin 2	B25
MCU_BOOTMODE03	I	MCU Bootmode Pin 3	D26
MCU_BOOTMODE04	I	MCU Bootmode Pin 4	E24

**表 6-107. Sysboot Signal Descriptions (continued)**

SIGNAL NAME [1]	PIN TYPE [2]	DESCRIPTION [3]	ALZ PIN [4]
MCU_BOOTMODE05	I	MCU Bootmode Pin 5	C28
MCU_BOOTMODE06	I	MCU Bootmode Pin 6	B24
MCU_BOOTMODE07	I	MCU Bootmode Pin 7	D25
MCU_BOOTMODE08	I	MCU Bootmode Pin 8	C25
MCU_BOOTMODE09	I	MCU Bootmode Pin 9	C24

### 6.3.30.2 Clock

**表 6-108. Clock0 Signal Descriptions**

SIGNAL NAME [1]	PIN TYPE [2]	DESCRIPTION [3]	ALZ PIN [4]
WKUP_LF_CLKIN	I	Low Frequency (32.768 KHz) Oscillator Input	J27
WKUP_OSC0_XI	I	High Frequency Oscillator Input	H28
WKUP_OSC0_XO	O	High Frequency Oscillator Output	J28

**表 6-109. Clock1 Signal Descriptions**

SIGNAL NAME [1]	PIN TYPE [2]	DESCRIPTION [3]	ALZ PIN [4]
OSC1_XI	I	High Frequency Oscillator Input	M28
OSC1_XO	O	High Frequency Oscillator Output	L28

### 6.3.30.3 System

**表 6-110. MCU System Signal Descriptions**

SIGNAL NAME [1]	PIN TYPE [2]	DESCRIPTION [3]	ALZ PIN [4]
MCU_CLKOUT0	OZ	Reference clock output for Ethernet PHYs (50MHz or 25MHz)	F25
MCU_EXT_REFCLK0	I	External system clock input	F27, K26
MCU_OBSCLK0	O	Observation clock output for test and debug purposes only	C26, F25
MCU_PORz	I	MCU Domain Cold Reset	G23
MCU_RESETSTATz	O	MCU Domain Warm Reset status output	A23
MCU_RESETz	I	MCU Domain Warm Reset	A26
MCU_SAFETY_ERRORn	IO	Error signal output from MCU Domain ESM	J23
MCU_SYSCLKOUT0	O	MCU Domain system clock output for test and debug purposes only	F27

**表 6-111. System Signal Descriptions**

SIGNAL NAME [1]	PIN TYPE [2]	DESCRIPTION [3]	ALZ PIN [4]
AUDIO_EXT_REFCLK0	IO	External clock routed to ATL or McASP as one of the selectable input clock sources, or as a output clock output for ATL or McASP	AD24
AUDIO_EXT_REFCLK1	IO	External clock routed to ATL or McASP as one of the selectable input clock sources, or as a output clock output for ATL or McASP	Y25
EXTINTn	I	External Interrupt	AG24
EXT_REFCLK1	I	External clock input to Main Domain, routed to Timer clock muxes as one of the selectable input clock sources for Timer/WDT modules, or as reference clock to MAIN_PLL2 (PER1 PLL)	AD28
GPMC0_FCLK_MUX	O	GPMC functional clock output selected through a mux logic	AD27

表 6-111. System Signal Descriptions (continued)

SIGNAL NAME [1]	PIN TYPE [2]	DESCRIPTION [3]	ALZ PIN [4]
OBSCLK0	O	Observation clock output for test and debug purposes only	AG25
OBSCLK1	O	Observation clock output for test and debug purposes only	Y26
PMIC_POWER_EN1	O	Power enable output for MAIN Domain supplies	G26
PMIC_WAKE0	OD	PMIC WakeUp	AD24
PMIC_WAKE1	O	PMIC WakeUp	K26
PORz	I	SoC PORz Reset Signal	K23
RESETSTATz	O	Main Domain Warm Reset status output	AF27
RESET_REQz	I	Main Domain external Warm Reset request input	A24
SOC_SAFETY_ERRORn	IO	Error signal output from Main Domain ESM	AF25
SYNC0_OUT	O	CPTS Time Stamp Generator Bit 0	AB26
SYNC1_OUT	O	CPTS Time Stamp Generator Bit 1	AD28
SYNC2_OUT	O	CPTS Time Stamp Generator Bit 2	T28
SYNC3_OUT	O	CPTS Time Stamp Generator Bit 3	Y27
SYSCLKOUT0	O	SYSCLK0 output from Main PLL controller (divided by 6) for test and debug purposes only	AE25

## 6.3.30.4 EFUSE

表 6-112. EFUSE Signal Descriptions

SIGNAL NAME [1]	PIN TYPE [2]	DESCRIPTION [3]	ALZ PIN [4]
VPP_CORE	PWR	Programming Voltage for MAIN Domain Efuses	V22
VPP_MCU	PWR	Programming Voltage for MCU Domain Efuses	H22

## 6.3.30.5 VMON

表 6-113. VMON Signal Descriptions

SIGNAL NAME [1]	PIN TYPE [2]	DESCRIPTION [3]	ALZ PIN [4]
VMON1_ER_VSYS	A	Voltage Monitor, fixed 0.45V (+/-3%) threshold. Use with external precision voltage divider to monitor a higher voltage rail such as the PMIC input supply.	H23
VMON2_IR_VCPU	A	Must be externally connected directly to VDD_CPU	M18
VMON3_IR_VEXT1P8	A	General purpose voltage monitor for external supplies, 1.8V threshold. With internal resistor divider.	L22
VMON4_IR_VEXT1P8	A	General purpose voltage monitor for external supplies, 1.8V threshold. With internal resistor divider.	N19
VMON5_IR_VEXT3P3	A	General purpose voltage monitor for external supplies, 3.3V threshold. With internal resistor divider.	N20
VMON6_IR_VEXT0P8	A	General purpose voltage monitor for external supplies, 0.8V threshold. With internal resistor divider.	L18

## 6.3.31 Power

表 6-114. Power Supply Signal Descriptions

SIGNAL NAME [1]	PIN TYPE [2]	DESCRIPTION [3]	ALZ PIN [4]
CAP_VDDSD0 <sup>(1)</sup>	CAP	External Capacitor Connection	T21
CAP_VDDSD0_MCU <sup>(1)</sup>	CAP	External Capacitor Connection	J20
CAP_VDDSD1_MCU <sup>(1)</sup>	CAP	External Capacitor Connection	G16
CAP_VDDSD2 <sup>(1)</sup>	CAP	External Capacitor Connection	P21

**表 6-114. Power Supply Signal Descriptions (continued)**

SIGNAL NAME [1]	PIN TYPE [2]	DESCRIPTION [3]	ALZ PIN [4]
CAP_VDDS2_MCU <sup>(1)</sup>	CAP	External Capacitor Connection	H17
CAP_VDDS5 <sup>(1)</sup>	CAP	External Capacitor Connection	M22
VDDAR_CORE	PWR	Core RAM Supply	N17, V11, V16, Y20
VDDAR_CPU	PWR	CPU RAM Supply	H9, K14, P11, P14, V13
VDDAR_MCU	PWR	MCU RAM Supply	K17, K19
VDDA_0P8_DSITX	PWR	Analog Supply for DSITX	AB14
VDDA_0P8_DSITX_C	PWR	DSITX Clock Supply	AB15
VDDA_0P8_USB	PWR	USB 0.8V Supply	AB8
VDDA_0P8_CSIRX0_1	PWR	Analog Supply for CSIRX	AB17, AB18
VDDA_0P8_DLL_MMC0	PWR	MMC DLL Analog Supply	W7
VDDA_0P8_PLL_DDR0	PWR	DDR de-skew PLL Analog Supply	P10
VDDA_0P8_PLL_DDR1	PWR	DDR de-skew PLL Analog Supply	J14
VDDA_0P8_SERDES0_1	PWR	SERDES 0.8V Supply	AB10, AB11
VDDA_0P8_SERDES_C0_1	PWR	SERDES 0.8V Clock Supply	AA10, AA11
VDDA_1P8_DSITX	PWR	Analog Supply for DSITX	AA14, AA15
VDDA_1P8_USB	PWR	USB 1.8V Supply	AB7
VDDA_1P8_CSIRX0_1	PWR	Analog Supply for CSIRX	AA17, AA19
VDDA_1P8_SERDES0_1	PWR	SERDES 1.8V Supply	AA12
VDDA_1P8_SERDES2_4	PWR	SERDES 1.8V Supply	AB13
VDDA_3P3_USB	PWR	USB 3.3V Supply	AB9
VDDA_ADC0	PWR	ADC0 Analog Supply	J21
VDDA_ADC1	PWR	ADC1 Analog Supply	K21
VDDA_MCU_PLLGRP0	PWR	Analog Supply for MCU PLL Group 0	K22
VDDA_MCU_TEMP	PWR	Analog Supply for MCU temperature sensor	J17
VDDA_OSC1	PWR	HFOSC1 Supply	L21
VDDA_PLLGRP0	PWR	Analog Supply for MAIN PLL Group 0	U18
VDDA_PLLGRP1	PWR	Analog Supply for MAIN PLL Group 1	V19
VDDA_PLLGRP2	PWR	Analog Supply for MAIN PLL Group 2	Y11
VDDA_PLLGRP5	PWR	Analog Supply for MAIN PLL Group 5	N14
VDDA_PLLGRP6	PWR	Analog Supply for MAIN PLL Group 6	R12
VDDA_PLLGRP7	PWR	Analog Supply for MAIN PLL Group 7	R11
VDDA_PLLGRP8	PWR	Analog Supply for MAIN PLL Group 8	K12
VDDA_PLLGRP9	PWR	Analog Supply for MAIN PLL Group 9	T18
VDDA_PLLGRP10	PWR	Analog Supply for MAIN PLL Group 10	Y16
VDDA_PLLGRP12	PWR	Analog Supply for MAIN PLL Group 12	Y18
VDDA_PLLGRP13	PWR	Analog Supply for MAIN PLL Group 13	V12
VDDA_POR_WKUP	PWR	WKUP domain Analog Supply	L20
VDDA_TEMP0	PWR	Analog Supply for temperature sensor 0	U19
VDDA_TEMP1	PWR	Analog Supply for temperature sensor 1	K10
VDDA_TEMP2	PWR	Analog Supply for temperature sensor 2	T16
VDDA_TEMP3	PWR	Analog Supply for temperature sensor 3	U10
VDDA_TEMP4	PWR	Analog Supply for temperature sensor 4	Y14
VDDA_WKUP	PWR	Oscillator Supply for WKUP domain	J22
VDDSHV0	PWR	IO Power Supply	R21, U21, U22
VDDSHV0_MCU	PWR	IO Power Supply	H19, H20

表 6-114. Power Supply Signal Descriptions (continued)

SIGNAL NAME [1]	PIN TYPE [2]	DESCRIPTION [3]	ALZ PIN [4]
VDDSHV1_MCU	PWR	IO Power Supply	H16, J16
VDDSHV2	PWR	IO Power Supply	M20, R20
VDDSHV2_MCU	PWR	IO Power Supply	G18, H18
VDDSHV5	PWR	IO Power Supply	M21, N22
VDDS_DDR	PWR	DDR PHY IO Supply	A1, A18, AA1, G10, G12, G14, G6, H11, H13, H15, J6, L6, N6, N9, P7, P8, R6, U9
VDDS_DDR_C0	PWR	IO Power Supply for DDR Clock	R9
VDDS_DDR_C1	PWR	IO Power Supply for DDR Clock	J12
VDDS_MMC0	PWR	MMC0 PHY IO Supply	Y7, Y8
VDD_CORE	PWR	MAIN domain core Supply	AA21, AB20, J13, J15, M16, M19, N10, P18, R17, R19, T10, T20, U15, U17, U8, V14, V18, V20, V7, V9, W10, W13, W15, W17, W19, W21, W8, Y12, Y22, Y9
VDD_CPU	PWR	CPU core Supply	G8, H7, J8, K11, K13, K7, K9, L8, M14, M7, M9, N11, N15, P16, R13, R15, T12, T14, U11, U13
VDD_MCU	PWR	MCU core Supply	K16, K18, L15, L17, L19
VDD_MCU_WAKE1	PWR	Core Supply for MCU daisy chain	J19
VDD_WAKE0	PWR	Core Supply for MAIN domain daisy chain	P20

表 6-114. Power Supply Signal Descriptions (continued)

SIGNAL NAME [1]	PIN TYPE [2]	DESCRIPTION [3]	ALZ PIN [4]
VSS	GND	Ground	A14, A5, AA13, AA16, AA18, AA20, AA22, AA3, AA5, AA7, AA9, AB12, AB16, AB19, AB2, AB21, AB23, AB4, AB6, AC11, AC22, AC26, AC3, AC5, AC7, AC8, AD15, AD18, AD21, AD6, AD9, AE10, AE14, AE17, AE20, AE23, AE4, AE7, AF12, AF15, AF18, AF21, AF24, AF5, AF8, AG10, AG14, AG17, AG20, AG23, AG4, AG7, AH1, AH12, AH15, AH18, AH21, AH24, AH3, AH6, AH9, B11, B13, B15, B17, B2, B23, B4, B6, B8, C1, C12, C14, C16, C18, C3, C5, C7, D11, D13, D15, D17, D2, D4, D6, D8, E1, E12, E14, E16, E26, E3, E5, E7, F2, F4, F6, G13, G28, G3, G5, G7, G9, H10, H12, H14, H2, H21, H4, H6, H8, J1, J11, J18, J24, J3, J5, J7, J9, K15, K2, K20, K27, K4, K6, K8, L14, L16, L3, L5, L7, L9, M15, M17, M2, M25, M4, M6, M8, N1, N16, N18, N21, N23, N3, N7, P15, P17, P19, P22, P6, P9, R10, R14, R16, R18, R23, R26, R7, T11, T13, T15, T17, T19, T2, T22, T4, T6, T9, U12, U14, U16, U20, U23, U3, U5, U7, V10, V15, V17, V2, V21, V24, V4, V6, V8, W1, W11, W12, W14, W16, W18, W20, W22, W26, W3, W6, W9, Y10, Y13, Y15, Y17, Y19, Y2, Y21, Y23, Y4, Y6

(1) This pin must always be connected via a 1- $\mu$ F  $\pm$ 10% capacitor to VSS.

## 6.4 Connection for Unused Pins

This section describes connectivity requirements for package balls that have specific connectivity requirements and unused package balls.

### 备注

All power balls must be supplied with the voltages specified in the [Recommended Operating Conditions](#) section, unless otherwise specified in [Signal Descriptions](#).

### 备注

For additional clarification, "left unconnected" or "no connect" (NC) means no signal traces can be connected to these device ball number.

表 6-115 shows the connectivity requirements for specific signals by ball name and ball number.

表 6-115. Connectivity Requirements

BALL NUMBER	BALL NAME	CONNECTION REQUIREMENT
H28	WKUP_OSC0_XI	Each of these balls must be connected to VSS through a separate external pull resistor to ensure these balls are held to a valid logic low level, if unused.
M28	OSC1_XI	
B28	TRSTN	
G1	DDR0_DQS0P	
L1	DDR0_DQS1P	
V1	DDR0_DQS2P	
AB1	DDR0_DQS3P	
A16	DDR1_DQS0P	
A13	DDR1_DQS1P	
A6	DDR1_DQS2P	
A3	DDR1_DQS3P	
T8	DDR0_RET	
J10	DDR1_RET	
H23	VMON1_ER_VSYS	
L18	VMON6_IR_VEXT0P8	
L22	VMON3_IR_VEXT1P8	
M18	VMON2_IR_VCPU	
N19	VMON4_IR_VEXT1P8	
N20	VMON5_IR_VEXT3P3	
L25	MCU_ADC0_AIN0	
K25	MCU_ADC0_AIN1	
M24	MCU_ADC0_AIN2	
L24	MCU_ADC0_AIN3	
L27	MCU_ADC0_AIN4	
K24	MCU_ADC0_AIN5	
M27	MCU_ADC0_AIN6	
M26	MCU_ADC0_AIN7	
P25	MCU_ADC1_AIN0	
R25	MCU_ADC1_AIN1	
P28	MCU_ADC1_AIN2	
P27	MCU_ADC1_AIN3	
N25	MCU_ADC1_AIN4	
P26	MCU_ADC1_AIN5	
N26	MCU_ADC1_AIN6	
N27	MCU_ADC1_AIN7	
AC10	SERDES0_REXT	Each of these balls must be connected to VSS through a separate external pull resistor to ensure these balls are held to a valid logic low level, if unused. Refer to <a href="#">Signal Descriptions</a> footnote for appropriate value of pull-resistor for each signal.
AC18	CSI0_RXRCALIB	
AC21	CSI1_RXRCALIB	
R8	DDR0_CAL0	
E8	DDR1_CAL0	
AC13	DSI0_TXRCALIB	
AC15	DSI1_TXRCALIB	
AA6	USB0_RCALIB	

**表 6-115. Connectivity Requirements (continued)**

BALL NUMBER	BALL NAME	CONNECTION REQUIREMENT	
A26	MCU_RESETZ	Each of these balls must be connected to the corresponding power supply through a separate external pull resistor to ensure these balls are held to a valid logic high level, if unused.	
G23	MCU_PORZ		
K23	PORZ		
A24	RESET_REQZ		
A25	TCK		
AG27	TMS		
G24	MCU_I2C0_SCL		
H24	WKUP_I2C0_SCL		
H27	WKUP_I2C0_SDA		
J25	MCU_I2C0_SDA		
AE24	I2C0_SDA		
AH25	I2C0_SCL		
AG24	EXTINTN		
AG28	TDI		
AE26	TDO		
A27	EMU0		
C26	EMU1		
H1	DDR0_DQS0N		
M1	DDR0_DQS1N		
U1	DDR0_DQS2N		
AC1	DDR0_DQS3N		
A15	DDR1_DQS0N		
A12	DDR1_DQS1N		
A7	DDR1_DQS2N		
A2	DDR1_DQS3N		
H22	VPP_MCU		Each of these balls must be left unconnected, if unused.
V22	VPP_CORE		
AF1	MMC0_CALPAD		
	DDR0_*	DDRSS0 and DDRSS1 must always be used in incremental order. For instance, when using a single LPDDR component, it must be connected to the DDR0_* interface. When using two LPDDR components, they must be connected to DDR0_* and DDR1_* interfaces.	
	DDR1_*		

表 6-116 shows the specific connection requirements for the RESERVED ball numbers on the device.

**备注**

For additional clarification, "left unconnected" or "no connect" (NC) means **no** signal traces can be connected to these device ball numbers.

**表 6-116. Reserved Balls Specific Connection Requirements**

BALL NUMBERS	CONNECTION REQUIREMENTS
AB22 / AC12 / AC14 / AC16 / AC17 / AC19 / AC20 / AC23 / AD10 / AD11 / AD12 / AD5 / AE11 / F13 / G11 / G21 / H25 / K28 / L23 / L26 / N28 / N8 / T7	RESERVED. These balls must be left unconnected.

## 7 Specifications

### 7.1 Absolute Maximum Ratings

over operating free-air temperature range (unless otherwise noted) <sup>(1)</sup> <sup>(2)</sup>

PARAMETER		MIN	MAX	UNIT
VDD_CORE	MAIN domain core supply	- 0.3	1.05	V
VDD_MCU	MCUSS core supply	- 0.3	1.05	V
VDD_CPU	CPU core supply	- 0.3	1.05	V
VDD_MCU_WAKE1	Core supply for MCU WAKE function	- 0.3	1.05	V
VDD_WAKE0	Core supply for MAIN domain WAKE function	- 0.3	1.05	V
VDDA_0P8_DLL_MMC0	MMC0 DLL analog supply	- 0.3	1.05	V
VDDAR_CORE	MAIN domain RAM supply	- 0.3	1.05	V
VDDAR_MCU	MCUSS RAM supply	- 0.3	1.05	V
VDDAR_CPU	CPU RAM supply	- 0.3	1.05	V
VDDA_0P8_DSITX	DSITX clock supply	- 0.3	1.05	V
VDDA_0P8_DSITX_C	DSITX clock supply	- 0.3	1.05	V
VDDA_0P8_CSIRX0_1	CSIRX analog supply low	- 0.3	1.05	V
VDDA_0P8_SERDES0_1	SERDES0-1 analog supply low	- 0.3	1.05	V
VDDA_0P8_SERDES_C0_1	SERDES0-1 clock supply	- 0.3	1.05	V
VDDA_0P8_USB	USB0-1 0.8 V analog supply	- 0.3	1.05	V
VDDA_0P8_PLL_DDR0	DDR0 PLL analog supply	- 0.3	1.05	V
VDDA_0P8_PLL_DDR1	DDR1 PLL analog supply	- 0.3	1.05	V
VDDA_1P8_USB	USB0-1 1.8 V analog supply	- 0.3	2.2	V
VDDA_1P8_DSITX	DSITX analog supply high	- 0.3	2.2	V
VDDA_1P8_CSIRX0_1	CSIRX analog supply high	- 0.3	2.2	V
VDDA_1P8_SERDES0_1	SERDES0-1 analog supply high	- 0.3	2.2	V
VDDA_1P8_SERDES2_4	SERDES2-4 analog supply high	- 0.3	2.2	V
VDDA_3P3_USB	USB0-1 3.3 V analog supply	- 0.3	3.8	V
VDDA_MCU_PLLGRP0	Analog supply for MCU PLL Group 0	- 0.3	2.2	V
VDDA_PLLGRP0	Analog supply for Main PLL Group 0	- 0.3	2.2	V
VDDA_PLLGRP1	Analog supply for Main PLL Group 1	- 0.3	2.2	V
VDDA_PLLGRP2	Analog supply for Main PLL Group 2	- 0.3	2.2	V
VDDA_PLLGRP5	Analog supply for MAIN PLL Group 5 (DDR)	- 0.3	2.2	V
VDDA_PLLGRP6	Analog supply for MAIN PLL Group 6	- 0.3	2.2	V
VDDA_PLLGRP7	Analog supply for MAIN PLL Group 7	- 0.3	2.2	V
VDDA_PLLGRP8	Analog supply for MAIN PLL Group 8	- 0.3	2.2	V
VDDA_PLLGRP9	Analog supply for MAIN PLL Group 9	- 0.3	2.2	V
VDDA_PLLGRP10	Analog supply for MAIN PLL Group 10	- 0.3	2.2	V
VDDA_PLLGRP12	Analog supply for MAIN PLL Group 12	- 0.3	2.2	V
VDDA_PLLGRP13	Analog supply for MAIN PLL Group 13	- 0.3	2.2	V
VDDA_WKUP	Oscillator supply for WKUP domain	- 0.3	2.2	V
VDDA_ADC0	ADC analog supply	- 0.3	2.2	V
VDDA_ADC1	ADC analog supply	- 0.3	2.2	V
VDDA_MCU_TEMP	Analog supply for temperature sensor 0 in MCU domain	- 0.3	2.2	V

## 7.1 Absolute Maximum Ratings (continued)

over operating free-air temperature range (unless otherwise noted) <sup>(1)</sup> <sup>(2)</sup>

PARAMETER		MIN	MAX	UNIT	
VDDA_POR_WKUP	WKUP domain analog supply	- 0.3	2.2	V	
VDDA_TEMP_0	Analog supply for temperature sensor 0	- 0.3	2.2	V	
VDDA_TEMP_1	Analog supply for temperature sensor 1	- 0.3	2.2	V	
VDDA_TEMP_2	Analog supply for temperature sensor 2	-0.3	2.2	V	
VDDA_TEMP_3	Analog supply for temperature sensor 3	- 0.3	2.2	V	
VDDA_TEMP_4	Analog supply for temperature sensor 4	- 0.3	2.2	V	
VDDA_OSC1	HFOSC1 supply	- 0.3	2.2	V	
VDDS_DDR	DDR interface power supply	- 0.3	1.2	V	
VDDS_DDR_C0	IO power for DDR0 Memory Clock Bit (MCB) macro	- 0.3	1.2	V	
VDDS_DDR_C1	IO power for DDR1 Memory Clock Bit (MCB) macro	- 0.3	1.2	V	
VDDS_MMC0	MMC0 IO supply	- 0.3	2.2	V	
VDDSHV0_MCU	IO supply MCUSS general IO group, and MCU and MAIN domain warm reset pins	1.8 V	- 0.3	2.2	V
		3.3 V	- 0.3	3.8	
VDDSHV0	IO supply for MAIN domain general	1.8 V	- 0.3	2.2	V
		3.3 V	- 0.3	3.8	
VDDSHV1_MCU	IO supply for MCUSS IO group 1	1.8 V	- 0.3	2.2	V
		3.3 V	- 0.3	3.8	
VDDSHV2_MCU	IO supply for MCUSS IO group 2	1.8 V	- 0.3	2.2	V
		3.3 V	- 0.3	3.8	
VDDSHV2	IO supply for MAIN domain IO group 2	1.8 V	- 0.3	2.2	V
		3.3 V	- 0.3	3.8	
VDDSHV5	IO supply for MAIN domain IO group 5	1.8 V	- 0.3	2.2	V
		3.3 V	- 0.3	3.8	
VPP_CORE	Supply voltage range for CORE EFUSE domain	- 0.3	1.89	V	
VPP_MCU	Supply voltage range for MCU EFUSE domain	- 0.3	1.89	V	
USB0_VBUS <sup>(8)</sup>	Voltage range for USB VBUS comparator input	- 0.3	3.6	V	
Steady State Max. Voltage at all fail-safe IO pins	I2C0_SCL, I2C0_SDA, WKUP_I2C0_SCL, WKUP_I2C0_SDA, MCU_I2C0_SCL, MCU_I2C0_SDA, EXTINTn	- 0.3	3.8	V	
	MCU_PORz, PORz	- 0.3	3.8		
Steady State Max. Voltage at all other IO pins <sup>(3)</sup>	VMON1_ER_VSYS, VMON3_IR_VEXT1P8, VMON4_IR_VEXT1P8,	- 0.3	2.2	V	
	VMON2_IR_VCPU, VMON6_IR_VEXT0P8 <sup>(7)</sup>	- 0.3	1.05		
	VMON5_IR_VEXT3P3 <sup>(7)</sup>	- 0.3	3.8		
	All other IO pins	- 0.3	IO supply voltage + 0.3		

## 7.1 Absolute Maximum Ratings (continued)

over operating free-air temperature range (unless otherwise noted) <sup>(1)</sup> <sup>(2)</sup>

PARAMETER		MIN	MAX	UNIT
Transient Overshoot and Undershoot specification at IO pin	20% of IO supply voltage for up to 20% of signal period (see 图 7-1, IO Transient Voltage Ranges)		$0.2 \times VDD^{(6)}$	V
Latch-up Performance, Class II (125°C) <sup>(4)</sup>	I-Test	- 100	100	mA
	Over-Voltage (OV) Test	NA	$1.5 \times VDD^{(6)}$	V
T <sub>STG</sub> <sup>(5)</sup>	Storage temperature	- 55	+150	°C

- (1) Operation outside the Absolute Maximum Ratings may cause permanent device damage. Absolute Maximum Ratings do not imply functional operation of the device at these or any other conditions beyond those listed under Recommended Operating Conditions. If used outside the [Recommended Operating Conditions](#) but within the Absolute Maximum Ratings, the device may not be fully functional, and this may affect device reliability, functionality, performance, and shorten the device lifetime.
- (2) All voltage values are with respect to their associated VSS or VSSA\_x, unless otherwise noted.
- (3) This parameter applies to all IO pins which are not fail-safe and the requirement applies to all values of IO supply voltage. For example, if the voltage applied to a specific IO supply is 0 volts the valid input voltage range for any IO powered by that supply will be - 0.3 to +0.3 volts. Special attention should be applied anytime peripheral devices are not powered from the same power sources used to power the respective IO supply. It is important the attached peripheral never sources a voltage outside the valid input voltage range, including power supply ramp-up and ramp-down sequences.
- (4) For current pulse injection:  
Pins stressed per JEDEC JESD78E (Class II) and passed with specified I/O pin injection current and clamp voltage of 1.5 times maximum recommended I/O voltage and negative 0.5 times maximum recommended I/O voltage.  
For overvoltage performance:  
Supplies stressed per JEDEC JESD78E (Class II) and passed specified voltage injection.
- (5) For tape and reel the storage temperature range is [ - 10°C; +50°C] with a maximum relative humidity of 70%. TI recommends returning to ambient room temperature before usage.
- (6) VDD is the voltage on the corresponding power-supply pin(s) for the IO.
- (7) The VMON pins provides a way to monitor the system power supply. For more information, see [System Power Supply Monitor Design Guidelines using VMON/POK](#).
- (8) An external resistor divider is required to limit the voltage applied to this device pin. For more information, see [USB VBUS Design Guidelines](#).

Fail-safe IO terminals are designed such they do not have dependencies on the respective IO power supply voltage. This allows external voltage sources to be connected to these IO terminals when the respective IO power supplies are turned off. The specific signals that are fail safe are highlighted in the parameter "Steady State Max. Voltage at all fail-safe IO pins". All other IO terminals are not fail-safe and the voltage applied to them should be limited to the value defined by the "Steady State Max. Voltage at all other IO pins" parameter in [Absolute Maximum Ratings](#).

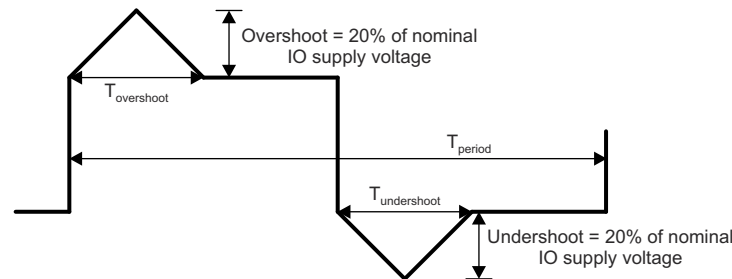

A.  $T_{overshoot} + T_{undershoot} < 20\% \text{ of } T_{period}$

图 7-1. IO Transient Voltage Ranges

## 7.2 ESD Ratings

			VALUE	UNIT	
V <sub>(ESD)</sub>	Electrostatic discharge	Human-body model (HBM), per AEC Q100-002 <sup>(1)</sup>	±1000	V	
		Charged-device model (CDM), per AEC Q100-011	All pins		±250
			Corner pins (A1, AJ29)		±750

(1) AEC Q100-002 indicates that HBM stressing shall be in accordance with the ANSI/ESDA/JEDEC JS-001 specification.

## 7.3 Recommended Operating Conditions

over operating free-air temperature range (unless otherwise noted)

SUPPLY NAME <sup>(2)</sup>	DESCRIPTION	MIN <sup>(1)</sup>	NOM	MAX <sup>(1)</sup>	UNIT
VDD_CORE	Boot/Active voltage for MAIN domain core supply	0.76 <sup>(1)</sup>	0.8	0.84 <sup>(1)</sup>	V
VDD_MCU	Boot/Active voltage for MCUSS core supply	0.76 <sup>(1)</sup>	0.8	0.89 <sup>(1)</sup>	V
VDD_CPU	Boot voltage for CPU core supply, applied at cold power up event	0.76 <sup>(1)</sup>	0.8	0.84 <sup>(1)</sup>	V
	Active voltage for CPU core supply, after AVS mode enabled in software	AVS <sup>(5)</sup> -5% (1)	AVS <sup>(5)</sup>	AVS <sup>(5)</sup> +5% (1)	V
VDD_CPU AVS Range	AVS valid voltage range for VDD_CPU	0.6		0.9	V
VDD_MCU_WAKE1	Core supply for MCU WAKE function	0.76	0.8	0.89	V
VDD_WAKE0	Core supply for MAIN domain WAKE function	0.76	0.8	0.89	V
VDDA_0P8_DLL_MMC0	MMC PLL analog supply	0.76	0.8	0.84	V
VDDAR_CORE	Main domain RAM supply	0.81	0.85	0.89	V
VDDAR_MCU	MCUSS RAM supply	0.81	0.85	0.89	V
VDDAR_CPU	CPU RAM supply	0.81	0.85	0.89	V
VDDA_0P8_DSITX	DSITX clock supply	0.76	0.8	0.84	V
VDDA_0P8_DSITX_C	DSITX clock supply	0.76	0.8	0.84	V
VDDA_0P8_CSIRX0_1	CSIRX analog supply low	0.76	0.8	0.84	V
VDDA_0P8_SERDES0_1	SERDES0-1 analog supply low	0.76	0.8	0.84	V
VDDA_0P8_SERDES_C0_1	SERDES0-1 clock supply	0.76	0.8	0.84	V
VDDA_0P8_USB	USB0-1 0.8v analog supply	0.76	0.8	0.84	V
VDDA_0P8_PLL_DDR0	DDR0 PLL analog supply low	0.76	0.8	0.84	V
VDDA_0P8_PLL_DDR1	DDR1 PLL analog supply low	0.76	0.8	0.84	V
VDDA_1P8_USB	USB0-1 1.8v analog supply	1.71	1.8	1.89	V
VDDA_1P8_DSITX	DSITX analog supply high	1.71	1.8	1.89	V
VDDA_1P8_CSIRX0_1	CSIRX analog supply high	1.71	1.8	1.89	V
VDDA_1P8_SERDES0_1	SERDES0-1 analog supply high	1.71	1.8	1.89	V
VDDA_1P8_SERDES2_4	SERDES2-4 analog supply high	1.71	1.8	1.89	V
VDDA_3P3_USB	USB0-1 3.3v analog supply	3.14	3.3	3.46	V
VDDA_MCU_PLLGRP0	Analog supply for MCU PLL Group 0	1.71	1.8	1.89	V
VDDA_PLLGRP0	Analog supply for Main PLL Group 0	1.71	1.8	1.89	V
VDDA_PLLGRP1	Analog supply for MAIN PLL Group 1	1.71	1.8	1.89	V
VDDA_PLLGRP2	Analog supply for MAIN PLL Group 2	1.71	1.8	1.89	V
VDDA_PLLGRP5	Analog supply for MAIN PLL Group 5 (DDR)	1.71	1.8	1.89	V
VDDA_PLLGRP6	Analog supply for MAIN PLL Group 6	1.71	1.8	1.89	V
VDDA_PLLGRP7	Analog supply for MAIN PLL Group 7	1.71	1.8	1.89	V
VDDA_PLLGRP8	Analog supply for MAIN PLL Group 8	1.71	1.8	1.89	V
VDDA_PLLGRP9	Analog supply for MAIN PLL Group 9	1.71	1.8	1.89	V

**TDA4VE-Q1, TDA4AL-Q1, TDA4VL-Q1**

ZHCSRF7A - DECEMBER 2022 - REVISED AUGUST 2023

over operating free-air temperature range (unless otherwise noted)

SUPPLY NAME <sup>(2)</sup>	DESCRIPTION		MIN <sup>(1)</sup>	NOM	MAX <sup>(1)</sup>	UNIT
VDDA_PLLGRP10	Analog supply for MAIN PLL Group 10		1.71	1.8	1.89	V
VDDA_PLLGRP12	Analog supply for MAIN PLL Group 12		1.71	1.8	1.89	V
VDDA_PLLGRP13	Analog supply for MAIN PLL Group 13		1.71	1.8	1.89	V
VDDA_WKUP	Oscillator supply for wkup domain		1.71	1.8	1.89	V
VDDA_ADC0	ADC analog supply		1.71	1.8	1.89	V
VDDA_ADC1	ADC analog supply		1.71	1.8	1.89	V
VDDA_MCU_TEMP	Analog supply for temperature sensor 0 in MCU domain		1.71	1.8	1.89	V
VDDA_POR_WKUP	WKUP domain analog supply		1.71	1.8	1.89	V
VDDA_1P8_MLB	MLB IO supply (6-pin interface)		1.71	1.8	1.89	V
VDDA_TEMP_0	Analog supply for temperature sensor 0		1.71	1.8	1.89	V
VDDA_TEMP_1	Analog supply for temperature sensor 1		1.71	1.8	1.89	V
VDDA_TEMP_2	Analog supply for temperature sensor 2		1.71	1.8	1.89	V
VDDA_TEMP_3	Analog supply for temperature sensor 3		1.71	1.8	1.89	V
VDDA_TEMP_4	Analog supply for temperature sensor 4		1.71	1.8	1.89	V
VDDA_OSC1	Analog supply for HFOSC1		1.71	1.8	1.89	V
VDDA_*	Peak to Peak Noise for all VDDA inputs				25	mV
VDDS_DDR <sup>(3)</sup>	DDR interface power supply		1.06	1.1	1.15	V
VDDS_DDR_C0	IO power for DDR0 Memory Clock Bit (MCB) macro		1.06	1.1	1.15	V
VDDS_DDR_C1	IO power for DDR1 Memory Clock Bit (MCB) macro		1.06	1.1	1.15	V
VDDS_MMC0	MMC0 IO supply		1.71	1.8	1.89	V
VDDSHV0	IO supply for main domain general	1.8-V operation	1.71	1.8	1.89	V
		3.3-V operation	3.14	3.3	3.46	V
VDDSHV0_MCU	IO supply MCUSS general IO group, and MCU and Main domain warm reset pins	1.8-V operation	1.71	1.8	1.89	V
		3.3-V operation	3.14	3.3	3.46	V
VDDSHV1_MCU <sup>(6)</sup>	IO supply for MCUSS IO group 1	1.8-V operation	1.71	1.8	1.89	V
		3.3-V operation	3.14	3.3	3.46	V
VDDSHV2	IO supply for main domain IO group 2	1.8-V operation	1.71	1.8	1.89	V
		3.3-V operation	3.14	3.3	3.46	V
VDDSHV2_MCU	IO supply for MCUSS IO group 2	1.8-V operation	1.71	1.8	1.89	V
		3.3-V operation	3.14	3.3	3.46	V
VDDSHV5	IO supply for main domain IO group 5	1.8-V operation	1.71	1.8	1.89	V
		3.3-V operation	3.14	3.3	3.46	V
USB0_VBUS	Voltage range for USB VBUS comparator input		0	See <sup>(7)</sup>	3.46	V
USB0_ID	Voltage range for the USB ID input			See <sup>(4)</sup>		V
VSS	Ground			0		V
T <sub>J</sub>	Operating junction temperature range	Automotive	-40		125	°C
		Extended	-40		105	°C
		Commercial	0		90	°C

- (1) For all VDD\* supply inputs, the voltage at the device ball must never be below the MIN voltage or above the MAX voltage for any amount of time. This requirement includes dynamic voltage events such as AC ripple, voltage transients, voltage dips, and so forth. This is required for all supply inputs, but special care should be given to the VDD\_CORE, VDD\_MCU, and VDD\_CPU domains which have higher transient current demand compared to other rails.
- (2) Refer to *Power-On-Hour (POH) Limits* for limitations.
- (3) VDDS\_DDR is required to still be powered with LPDDR4 voltage ranges, even if DDR interface is unused.
- (4) This terminal is connected to analog circuits in the respective USB PHY. The circuit sources a known current while measuring the voltage to determine if the terminal is connected to VSS with a resistance less than 10 Ω or greater than 100 kΩ. The terminal should

be connected to ground for USB host operation or open-circuit for USB peripheral operation, and should never be connected to any external voltage source.

- (5) The AVS Voltages are device-dependent, voltage domain-dependent, and OPP-dependent. They must be read from the VTM\_DEVINFO\_VDn. For information about VTM\_DEVINFO\_VDn Registers address, please refer to Voltage and Thermal Manager section in the device TRM. The power supply should be adjustable over the ranges shown in the VDD\_CPU AVS Range entry.
- (6) When DDR1 is used concurrently with either OSPI0 or Hyperbus, VDDSHV1\_MCU is limited to 1.8V (3.3V mode not supported if DDR1 is used in the system.)
- (7) An external resistor divider is required to limit the voltage applied to this device pin. For more information, see [USB VBUS Design Guidelines](#).

## 7.4 Power-On-Hour (POH) Limits

IP <sup>(1)</sup> (2) (3)	VOLTAGE DOMAIN	VOLTAGE (V) (MAX)	FREQUENCY (MHz) (MAX)	Tj(°C)	POH
All	100%	All	All Supported OPPs	Automotive -40°C to 125°C <sup>(4)</sup>	20000
All	100%	All	All Supported OPPs	Extended -40°C to 105°C	100000
All	100%	All	All Supported OPPs	Commercial 0°C to 90°C	100000

- (1) This information is provided solely for your convenience and does not extend or modify the warranty provided under TI's standard terms and conditions for TI semiconductor products.
- (2) Unless specified in the table above, all voltage domains and operating conditions are supported in the device at the noted temperatures.
- (3) POH is a function of voltage, temperature and time. Usage at higher voltages and temperatures will result in a reduction in POH.
- (4) Automotive profile is defined as 20000 power on hours with a junction temperature as follows: 5%@-40°C, 65%@70°C, 20%@110°C, and 10%@125°C.

## 7.5 Operating Performance Points

This section describes the operating conditions of the device. This section also contains the description of each Operating Performance Point (OPP) for processor clocks and device core clocks.

表 7-1 describes the maximum supported frequency per speed grade for the device.

**表 7-1. Speed Grade Maximum Frequency**

DEVICE	MAXIMUM FREQUENCY (MHz)										
	A72SS0	C71SS0/1	R5FSS0/1	MCU_R5SS0	GPU	CBASS0	VPAC	DMPAC	VENCDEC	DMSC	LPDDR4
T	2000	1000	1000	1000	800	500	720 <sup>(1)</sup>	520 <sup>(1)</sup>	550 (480MP/s)	333	4266 MT/s <sup>(2)</sup>
N	1600	750	1000	1000	800	500	600 <sup>(1)</sup>	433 <sup>(1)</sup>	275 (240MP/s)	333	3733 MT/s <sup>(2)</sup>
H	1200	500	1000	1000	800	500	600 <sup>(1)</sup>	300 <sup>(1)</sup>	275 (240 MP/s)	333	3200 MT/s <sup>(2)</sup>

- (1) Max VPAC and DMPAC speeds not available concurrently due to PLL sharing (max combinations are 720/480 and 650/520 for VPAC/DMPAC, respectively).
- (2) Maximum DDR Frequency will be limited based on the specific memory type (vendor) used in a system and by PCB implementation. TI strongly recommends all designs to follow the TI LPDDR4 EVM PCB layout exactly in every detail (routing, spacing, vias/backdrill, PCB material, etc.) in order to achieve the full specified clock frequency. Refer to the Jacinto 7 DDR Board Design and Layout Guidelines for details.

## 7.6 Electrical Characteristics

### 备注

The interfaces or signals described in 节 7.6.1 through 节 7.6.8 correspond to the interfaces or signals available in multiplexing mode 0 (Primary Function).

All interfaces or signals multiplexed on the balls described in these tables have the same DC electrical characteristics, unless multiplexing involves a PHY and GPIO combination, in which case different DC electrical characteristics are specified for the different multiplexing modes (Functions).

### 7.6.1 I2C, Open-Drain, Fail-Safe (I2C OD FS) Electrical Characteristics

Over recommended operating conditions (unless otherwise noted)

PARAMETER		TEST CONDITIONS	MIN	TYP	MAX	UNIT
<b>1.8-V MODE</b>						
V <sub>IL</sub>	Input low-level threshold				0.3 × VDDSHV <sup>(1)</sup>	V
V <sub>ILSS</sub>	Input low-level threshold steady state				0.3 × VDDSHV <sup>(1)</sup>	V
V <sub>IH</sub>	Input high-level threshold		0.7 × VDDSHV <sup>(1)</sup>			V
V <sub>IHSS</sub>	Input high-level threshold steady state		0.7 × VDDSHV <sup>(1)</sup>			V
V <sub>HYS</sub>	Input Hysteresis Voltage		0.1 × VDDSHV <sup>(1)</sup>			mV
I <sub>IN</sub>	Input Leakage Current	V <sub>I</sub> = 1.8 V or 0 V			±10	μA
V <sub>OL</sub>	Output low-level voltage				0.2 × VDDSHV <sup>(1)</sup>	V
I <sub>OL</sub>	Low Level Output Current	V <sub>OL(MAX)</sub>	6			mA
<b>3.3-V MODE</b>						
V <sub>IL</sub>	Input low-level threshold				0.3 × VDDSHV <sup>(1)</sup>	V
V <sub>ILSS</sub>	Input low-level threshold steady state				0.25 × VDDSHV <sup>(1)</sup>	V
V <sub>IH</sub>	Input high-level threshold		0.7 × VDDSHV <sup>(1)</sup>			V
V <sub>IHSS</sub>	Input high-level threshold steady state		0.7 × VDDSHV <sup>(1)</sup>			V
V <sub>HYS</sub>	Input Hysteresis Voltage		0.05 × VDDSHV <sup>(1)</sup>			mV
I <sub>IN</sub>	Input Leakage Current	V <sub>I</sub> = 3.3 V or 0 V			±10	μA
V <sub>OL</sub>	Output low-level voltage				0.4	V
I <sub>OL</sub>	Low Level Output Current	V <sub>OL(MAX)</sub>	6			mA

(1) VDDSHV stands for corresponding power supply. For more information on the power supply name and the corresponding ball, see the [Pin Attributes](#), POWER column.

### 7.6.2 Fail-Safe Reset (FS Reset) Electrical Characteristics

Over recommended operating conditions (unless otherwise noted)

PARAMETER		TEST CONDITIONS	MIN	TYP	MAX	UNIT
V <sub>IL</sub>	Input low-level threshold				0.3 × VDDSHV <sup>(1)</sup>	V
V <sub>ILSS</sub>	Input low-level threshold steady state				0.3 × VDDSHV <sup>(1)</sup>	V

Over recommended operating conditions (unless otherwise noted)

PARAMETER		TEST CONDITIONS	MIN	TYP	MAX	UNIT
V <sub>IH</sub>	Input high-level threshold		0.7 × VDDSHV <sup>(1)</sup>			V
V <sub>IHSS</sub>	Input high-level threshold steady state		0.7 × VDDSHV <sup>(1)</sup>			V
V <sub>HYS</sub>	Input Hysteresis Voltage		200			mV
I <sub>IN</sub>	Input Leakage Current	V <sub>I</sub> = 1.8 V or 0 V			±10	μA

(1) VDDSHV stands for corresponding power supply. For more information on the power supply name and the corresponding ball, see the *Pin Attributes*, POWER column.

### 7.6.3 HFOSC/LFOSC Electrical Characteristics

Over recommended operating conditions (unless otherwise noted)

PARAMETER		TEST CONDITIONS	MIN	TYP	MAX	UNIT
<b>HIGH FREQUENCY OSCILLATOR</b>						
V <sub>IH</sub>	Input high-level threshold		0.65 × VDDSHV <sup>(1)</sup>			V
V <sub>IL</sub>	Input low-level threshold				0.35 × VDDSHV <sup>(1)</sup>	V
V <sub>HYS</sub>	Input Hysteresis Voltage			49		mV
<b>LOW FREQUENCY OSCILLATOR</b>						
V <sub>IH</sub>	Input high-level threshold		0.65 × VDDA_WKUP <sup>(1)</sup>			V
V <sub>IL</sub>	Input low-level threshold				0.35 × VDDA_WKUP <sup>(1)</sup>	V
V <sub>HYS</sub>	Input Hysteresis Voltage	Active Mode		85		mV
		Bypass Mode		324		mV

(1) VDDSHV stands for corresponding power supply. For WKUP\_OSC0, the corresponding power supply is VDDA\_WKUP. For OSC1\_XI, the corresponding power supply is VDDS\_OSC1.

### 7.6.4 eMMC PHY Electrical Characteristics

Over operating free-air temperature range (unless otherwise noted)

PARAMETER		TEST CONDITIONS	MIN	NOM	MAX	UNIT
V <sub>IL</sub>	Input low-level threshold				0.35 × VDDSHV <sup>(1)</sup>	V
V <sub>ILSS</sub>	Input low-level threshold steady state				0.20	V
V <sub>IH</sub>	Input high-level threshold		0.65 × VDDSHV <sup>(1)</sup>			V
V <sub>IHSS</sub>	Input high-level threshold steady state		1.4			V
I <sub>IN</sub>	Input Leakage Current	V <sub>I</sub> = 1.8 V or 0 V			±10	μA
I <sub>OZ</sub>	Tri-state Output Leakage Current	V <sub>O</sub> = 1.8 V or 0 V			±10	μA
R <sub>PU</sub>	Pull-up Resistor		15	20	25	kΩ
R <sub>PD</sub>	Pull-down Resistor		15	20	25	kΩ
V <sub>OL</sub>	Output low-level voltage				0.30	V
V <sub>OH</sub>	Output high-level voltage		VDDSHV - 0.30 <sup>(1)</sup>			V
I <sub>OL</sub>	Low Level Output Current	V <sub>OL(MAX)</sub>	2			mA
I <sub>OH</sub>	High Level Output Current	V <sub>OH(MAX)</sub>	2			mA

Over operating free-air temperature range (unless otherwise noted)

PARAMETER		TEST CONDITIONS	MIN	NOM	MAX	UNIT
SR <sub>I</sub>	Input Slew Rate		5E +8			V/s

- (1) VDDSHV stands for corresponding power supply (vddshv8). For more information on the power supply name and the corresponding ball, see the *Pin Attributes*, POWER column..

### 7.6.5 SDIO Electrical Characteristics

Over operating free-air temperature range (unless otherwise noted)

PARAMETER		TEST CONDITIONS	MIN	NOM	MAX	UNIT
<b>1.8-V MODE</b>						
V <sub>IL</sub>	Input low-level threshold				0.58	V
V <sub>ILSS</sub>	Input low-level threshold steady state				0.58	V
V <sub>IH</sub>	Input high-level threshold		1.27			V
V <sub>IHSS</sub>	Input high-level threshold steady state		1.7			V
V <sub>HYS</sub>	Input Hysteresis Voltage		150			mV
I <sub>IN</sub>	Input Leakage Current	V <sub>I</sub> = 1.8 V or 0 V			±10	µA
R <sub>PU</sub>	Pull-up Resistor		40	50	60	kΩ
R <sub>PD</sub>	Pull-down Resistor		40	50	60	kΩ
V <sub>OL</sub>	Output low-level voltage				0.45	V
V <sub>OH</sub>	Output high-level voltage		VDDSHV-0.45 <sup>(1)</sup>			V
I <sub>OL</sub>	Low Level Output Current	V <sub>OL(MAX)</sub>	4			mA
I <sub>OH</sub>	High Level Output Current	V <sub>OH(MAX)</sub>	4			mA
<b>3.3-V Mode</b>						
V <sub>IL</sub>	Input low-level threshold				0.25 × VDDSHV <sup>(1)</sup>	V
V <sub>ILSS</sub>	Input low-level threshold steady state				0.15 × VDDSHV <sup>(1)</sup>	V
V <sub>IH</sub>	Input high-level threshold		0.625 × VDDSHV <sup>(1)</sup>			V
V <sub>IHSS</sub>	Input high-level threshold steady state		0.625 × VDDSHV <sup>(1)</sup>			V
V <sub>HYS</sub>	Input Hysteresis Voltage		150			mV
I <sub>IN</sub>	Input Leakage Current	V <sub>I</sub> = 1.8 V or 0 V			±10	µA
R <sub>PU</sub>	Pull-up Resistor		40	50	60	kΩ
R <sub>PD</sub>	Pull-down Resistor		40	50	60	kΩ
V <sub>OL</sub>	Output low-level voltage				0.125 × VDDSHV <sup>(1)</sup>	V
V <sub>OH</sub>	Output high-level voltage		0.75 × VDDSHV <sup>(1)</sup>			V
I <sub>OL</sub>	Low Level Output Current	V <sub>OL(MAX)</sub>	6			mA
I <sub>OH</sub>	High Level Output Current	V <sub>OH(MAX)</sub>	10			mA

- (1) VDDSHV stands for corresponding power supply (vddshv8). For more information on the power supply name and the corresponding ball, see the *Pin Attributes* , POWER column.

### 7.6.6 CSI2/DSI D-PHY Electrical Characteristics

Over operating free-air temperature range (unless otherwise noted)

PARAMETER		MIN	NOM	MAX	UNIT
<b>Low-Power Receiver (LP-RX)</b>					
V <sub>IH</sub>	Input high-level threshold	740			mV

Over operating free-air temperature range (unless otherwise noted)

PARAMETER		MIN	NOM	MAX	UNIT
V <sub>IL</sub>	Input low-level threshold			550	mV
V <sub>HYS</sub>	Hysteresis	25			mV
<b>Ultra-Low Power Receiver (ULP-RX)</b>					
V <sub>ITH</sub>	Input high-level threshold	740			mV
V <sub>ITL-ULPM</sub>	Input low-level threshold			300	mV
V <sub>HYS</sub>	Hysteresis	25			mV
<b>High Speed Receiver (HS-RX)</b>					
V <sub>IDTH</sub>	Differential input high-level threshold			40	mV
V <sub>IDTL</sub>	Differential input low-level threshold	-40			mV
V <sub>IDMAX</sub>	Maximum differential input voltage			270	mV
V <sub>ILHS</sub>	Single-ended input low-level threshold	-40			mV
V <sub>IHHS</sub>	Single-ended input high-level threshold			460	mV
V <sub>CMRXDC</sub>	Common-mode voltage	70		330	mV

### 7.6.7 ADC12B Electrical Characteristics

Over recommended operating conditions (unless otherwise noted)

PARAMETER		TEST CONDITIONS	MIN	TYP	MAX	UNIT
<b>Analog Input</b>						
V <sub>MCU_ADC0/1_AIN[7:0]</sub>	Full-scale Input Range		VSS	VDDA_ADC0/1		V
DNL	Differential Non-Linearity		-1	0.5	4	LSB
INL	Integral Non-Linearity			±1	±4	LSB
LSB <sub>GAIN-ERROR</sub>	Gain Error			±2		LSB
LSB <sub>OFFSET-ERROR</sub>	Offset Error			±2		LSB
C <sub>IN</sub>	Input Sampling Capacitance			5.5		pF
SNR	Signal-to-Noise Ratio	Input Signal: 200 kHz sine wave at -0.5 dB Full Scale		70		dB
THD	Total Harmonic Distortion	Input Signal: 200 kHz sine wave at -0.5 dB Full Scale		73		dB
SFDR	Spurious Free Dynamic Range	Input Signal: 200 kHz sine wave at -0.5 dB Full Scale		76		dB
SNR <sub>(PLUS)</sub>	Signal-to-Noise Plus Distortion	Input Signal: 200 kHz sine wave at -0.5 dB Full Scale		69		dB
R <sub>MCU_ADC0/1_AIN[0:7]</sub>	Input Impedance of MCU_ADC0/1_AIN[7:0]	f = input frequency		$[1/((65.97 \times 10^{-12}) \times f_{\text{SMPL\_CLK}})]$		Ω
I <sub>IN</sub>	Input Leakage	MCU_ADC0/1_AIN[7:0] = VSS			-10	μA
		MCU_ADC0/1_AIN[7:0] = VDDA_ADC0/1			24	μA
<b>Sampling Dynamics</b>						
F <sub>SMPL_CLK</sub>	SMPL_CLK Frequency			60		MHz

Over recommended operating conditions (unless otherwise noted)

PARAMETER		TEST CONDITIONS	MIN	TYP	MAX	UNIT
t <sub>C</sub>	Conversion Time			13		ADC0/1 SMPL_CLK K Cycles
t <sub>ACQ</sub>	Acquisition time		2		257	ADC0/1 SMPL_CLK K Cycles
T <sub>R</sub>	Sampling Rate	ADC0/1 SMPL_CLK = 60 MHz		4		MSPS
CCISO	Channel to Channel Isolation			100		dB
<b>General Purpose Input Mode<sup>(1)</sup></b>						
V <sub>IL</sub>	Input low-level threshold				0.35 × VDDA_ADC0/ 1	V
V <sub>ILSS</sub>	Input high-level threshold steady state				0.35 × VDDA_ADC0/ 1	V
V <sub>IH</sub>	Input high-level threshold		0.65 × VDDA_ADC0/ 1			V
V <sub>IHSS</sub>	Input high-level threshold steady state		0.65 × VDDA_ADC0/ 1			V
V <sub>HYS</sub>	Input Hysteresis Voltage		200			mV
I <sub>IN</sub>	Input Leakage Current	V <sub>I</sub> = 1.8 V or 0 V			6	μA

(1) MCU\_ADC0/1 can be configured to operate in General Purpose Input mode, where all MCU\_ADC0/1\_AIN[7:0] inputs are globally enabled to operate as digital inputs via the ADC0/1\_CTRL register (gpi\_mode\_en = 1).

### 7.6.8 LVCMOS Electrical Characteristics

Over recommended operating conditions (unless otherwise noted)

PARAMETER		TEST CONDITIONS	MIN	TYP	MAX	UNIT
<b>1.8-V MODE</b>						
V <sub>IL</sub>	Input Low Voltage				0.35 × VDD <sup>(1)</sup>	V
V <sub>ILSS</sub>	Input Low Voltage Steady State				0.3 × VDD <sup>(1)</sup>	V
V <sub>IH</sub>	Input High Voltage		0.65 × VDD <sup>(1)</sup>			V
V <sub>IHSS</sub>	Input High Voltage Steady State		0.85 × VDD <sup>(1)</sup>			V
V <sub>HYS</sub>	Input Hysteresis Voltage		150			mV
I <sub>IN</sub>	Input Leakage Current.	V <sub>I</sub> = 1.8 V or 0 V			±10	μA
R <sub>PU</sub>	Pull-up Resistor		15	22	30	kΩ
R <sub>PD</sub>	Pull-down Resistor		15	22	30	kΩ
V <sub>OL</sub>	Output Low Voltage				0.45	V
V <sub>OH</sub>	Output High Voltage		VDD <sup>(1)</sup> - 0.45			V
I <sub>OL</sub>	Low Level Output Current	V <sub>OL(MAX)</sub>	3			mA
I <sub>OH</sub>	High Level Output Current	V <sub>OH(MIN)</sub>	3			mA
<b>3.3-V MODE</b>						
V <sub>IL</sub>	Input Low Voltage				0.8	V
V <sub>ILSS</sub>	Input Low Voltage Steady State				0.6	V
V <sub>IH</sub>	Input High Voltage		2.0			V
V <sub>IHSS</sub>	Input High Voltage Steady State		2.0			V
V <sub>HYS</sub>	Input Hysteresis Voltage		150			mV

Over recommended operating conditions (unless otherwise noted)

PARAMETER		TEST CONDITIONS	MIN	TYP	MAX	UNIT
$I_{IN}$	Input Leakage Current.	$V_I = 3.3\text{ V or }0\text{ V}$			$\pm 10$	$\mu\text{A}$
$R_{PU}$	Pull-up Resistor		15	22	30	$\text{k}\Omega$
$R_{PD}$	Pull-down Resistor		15	22	30	$\text{k}\Omega$
$V_{OL}$	Output Low Voltage				0.4	V
$V_{OH}$	Output High Voltage		2.4			V
$I_{OL}$	Low Level Output Current	$V_{OL(MAX)}$	5			mA
$I_{OH}$	High Level Output Current	$V_{OH(MIN)}$	6			mA

(1) VDD stands for corresponding power supply. For more information on the power supply name and the corresponding ball, see the *Pin Attributes*, POWER column.

### 7.6.9 USB2PHY Electrical Characteristics

#### 备注

USB0 and USB1 Electrical Characteristics are compliant with Universal Serial Bus Revision 2.0 Specification dated April 27, 2000 including ECNs and Errata as applicable.

### 7.6.10 SerDes 2-L-PHY/4-L-PHY Electrical Characteristics

#### 备注

The PCIe interfaces are compliant with the electrical parameters specified in PCI Express® Base Specification Revision 4.0, September 27, 2017.

This Device imposes an additional limit on SERDES REFCLK when used in Input mode with internal termination enabled, as described by parameter  $V_{REFCLK\_TERM}$  in 表 7-2, *4-L-PHY SERDES REFCLK Electrical Characteristics*. Internal termination is enabled by default and must be disabled before applying a reference clock signal that exceeds the limits defined by  $V_{REFCLK\_TERM}$ . External termination should always be enabled on the source side.

**表 7-2. 4-L-PHY SERDES REFCLK Electrical Characteristics**

Only applies when internal termination is enabled. Over recommended operating conditions (unless otherwise noted)

PARAMETER		MIN	TYP	MAX	UNIT
$V_{REFCLK\_TERM}$	Single ended voltage threshold at the reference clock pin when internal termination is enabled			400	mV
$R_{TERM}$	Internal termination	40	50	62.5	$\Omega$

#### 备注

The SerDes USB interfaces are compliant with the USB3.1 SuperSpeed Transmitter and Receiver Normative Electrical Parameters as defined in the Universal Serial Bus 3.1 Specification, Revision 1.0, July 26, 2013.

#### 备注

The SGMII interfaces electrical characteristics are compliant with 1000BASE-KX per IEEE802.3 Clause 70.

备注

The SGMII 2.5G / XAUI interfaces electrical characteristics are compliant with IEEE802.3 Clause 47.

备注

The QSGMII interface electrical characteristics are compliant with QSGMII Specification revision 1.2.

备注

The UFS interface electrical characteristics are compliant with MIPI M-PHY Specification v3.1, February 17, 2014.

备注

The DP interface electrical characteristics are compliant with the VESA DisplayPort (DP) Standard v 1.4 February 23, 2016.

备注

The eDP interface electrical characteristics are compliant with the VESA Embedded DisplayPort (eDP) Standard v1.4b October 23, 2015.

### 7.6.13 DDR0 Electrical Characteristics

备注

The DDR interface is compatible with JESD209-4B standard compliant LPDDR4 SDRAM devices.

## 7.7 VPP Specifications for One-Time Programmable (OTP) eFuses

This section specifies the operating conditions required for programming the OTP eFuses and is applicable only for High-Security Devices.

### 7.7.1 Recommended Operating Conditions for OTP eFuse Programming

over operating free-air temperature range (unless otherwise noted)

PARAMETER	DESCRIPTION	MIN	NOM	MAX	UNIT
VDD_CORE	Supply voltage range for the core domain during OTP operation; OPP NOM (BOOT)	See <a href="#">Recommended Operating Conditions</a>			V
VDD_MCU	Supply voltage range for the core domain during OTP operation; OPP NOM (BOOT)	See <a href="#">Recommended Operating Conditions</a>			V
VPP_CORE	Supply voltage range for the eFuse ROM domain during normal operation	N/A <sup>(2)</sup>			
	Supply voltage range for the eFuse ROM domain during OTP programming <sup>(1)</sup>	1.71	1.8	1.89	V
VPP_MCU	Supply voltage range for the eFuse ROM domain during normal operation	N/A <sup>(2)</sup>			
	Supply voltage range for the eFuse ROM domain during OTP programming <sup>(1)</sup>	1.71	1.8	1.89	V

(1) Supply voltage range includes DC errors and peak-to-peak noise. TI power management solutions [TLV70018-Q1](#) from the TLV707x family meet the supply voltage range needed for VPP\_CORE and VPP\_MCU.

(2) N/A stands for Not Applicable.

### 7.7.2 Hardware Requirements

The following hardware requirements must be met when programming keys in the OTP eFuses:

- The VPP\_CORE and VPP\_MCU power supplies must be disabled when not programming OTP registers.
- The VPP\_CORE and VPP\_MCU power supplies must be ramped up after the proper device power-up sequence (for more details, see *Power Supply Sequencing*).

### 7.7.3 Programming Sequence

Programming sequence for OTP eFuses:

- Power on the board per the power-up sequencing. No voltage should be applied on the VPP\_CORE and VPP\_MCU terminals during power up and normal operation.
- Load the OTP write software required to program the eFuse (contact your local TI representative for the OTP software package).
- Apply the voltage on the VPP\_CORE and VPP\_MCU terminals according to the specification in [节 7.7.1](#).
- Run the software that programs the OTP registers.
- After validating the content of the OTP registers, remove the voltage from the VPP\_CORE and VPP\_MCU terminals.

### 7.7.4 Impact to Your Hardware Warranty

You recognize and accept at your own risk that your use of eFuse permanently alters the TI device. You acknowledge that eFuse can fail due to incorrect operating conditions or programming sequence. Such a failure may render the TI device inoperable and TI will be unable to confirm the TI device conformed to TI device specifications prior to the attempted eFuse. CONSEQUENTLY, TI WILL HAVE NO LIABILITY FOR ANY TI DEVICES THAT HAVE BEEN eFUSED.

## 7.8 Thermal Resistance Characteristics

This section provides the thermal resistance characteristics used on this device.

For reliability and operability concerns, the maximum junction temperature of the device has to be at or below the  $T_J$  value identified in [Recommended Operating Conditions](#).

### 7.8.1 Thermal Resistance Characteristics for ALZ Package

It is recommended to perform thermal simulations at the system level with the worst case device power consumption.

NO.	PARAMETER	DESCRIPTION	ALZ PACKAGE	
			$^{\circ}\text{C/W}^{(1)(3)}$	AIR FLOW (m/s) <sup>(2)</sup>
T1	$R_{\Theta JC}$	Junction-to-case	0.3	N/A
T2	$R_{\Theta JB}$	Junction-to-board	2.0	N/A
T3	$R_{\Theta JA}$	Junction-to-free air	10.4	0
T4		Junction-to-moving air	6.1	1
T5			5.3	2
T6			4.8	3
T7	$\Psi_{JT}$	Junction-to-package top	0.16	0
T8			0.17	1
T9			0.17	2
T10			0.17	3
T11	$\Psi_{JB}$	Junction-to-board	1.8	0
T12			1.5	1
T13			1.4	2
T14			1.4	3

(1) These values are based on a JEDEC defined 2S2P system (with the exception of the Theta JC [ $R_{\Theta JC}$ ] value, which is based on a JEDEC defined 1S0P system) and will change based on environment as well as application. For more information, see these EIA/ JEDEC standards:

- JESD51-2, *Integrated Circuits Thermal Test Method Environment Conditions - Natural Convection (Still Air)*
- JESD51-3, *Low Effective Thermal Conductivity Test Board for Leaded Surface Mount Packages*
- JESD51-6, *Integrated Circuit Thermal Test Method Environmental Conditions - Forced Convection (Moving Air)*
- JESD51-7, *High Effective Thermal Conductivity Test Board for Leaded Surface Mount Packages*
- JESD51-9, *Test Boards for Area Array Surface Mount Packages*

(2) m/s = meters per second.

(3)  $^{\circ}\text{C/W}$  = degrees Celsius per watt.

## 7.9 Temperature Sensor Characteristics

This section summarizes the Voltage and Temperature Module (VTM) on die temperature sensor characteristics.

For reliability and operability concerns, the maximum junction temperature of the device has to be at or below the  $T_J$  value identified in the [Recommended Operating Conditions](#).

**表 7-3. VTM Die Temperature sensor Characteristics**

PARAMETER		TEST CONDITIONS	MIN	TYP	MAX	UNIT
$T_{acc}$	VTM temperature sensor accuracy	- 40 to 110 °C	- 5		5	°C
		110 to 125 °C	- 2		2	°C

## 7.10 Timing and Switching Characteristics

### 备注

The timings presented in this section are valid when the DRV\_STR (Drive Strength) control in the associated PADCONFIG registers are set to the default “0h - Nominal (recommended)” value.

### 7.10.1 Timing Parameters and Information

The timing parameter symbols used in [Timing and Switching Characteristics](#) are created in accordance with JEDEC Standard 100. To shorten the symbols, some pin names and other related terminologies have been abbreviated in [表 7-4](#):

**表 7-4. Timing Parameters Subscripts**

SYMBOL	PARAMETER
c	Cycle time (period)
d	Delay time
dis	Disable time
en	Enable time
h	Hold time
su	Setup time
START	Start bit
t	Transition time
v	Valid time
w	Pulse duration (width)
X	Unknown, changing, or don't care level
F	Fall time
H	High
L	Low
R	Rise time
V	Valid
IV	Invalid
AE	Active Edge
FE	First Edge
LE	Last Edge
Z	High impedance

## 7.10.2 Power Supply Sequencing

This section describes power supply sequencing required to ensure proper device operation. The device can be operated using either an isolated or combined MCU & Main power distribution network (PDN). Two different primary power sequences are recommended based upon isolated and combined MCU & Main PDNs. In addition, the device can be operated in either MCU Only or DDR Retention or GPIO Retention low power modes. Two different desired device power supply sequences for entry and exit of low power modes are shown.

The power supply names used in this section are specific to this device and align to names given in the Signal Descriptions section. Common power supply names may be used across different devices within the Jacinto 7™ processor family. These common supply names will have very similar if not identical functions across devices.

All power sequencing timing diagrams shown will use the following terminology:

- Primary = Essential power sequences of all voltage domains between off and full active states.
- $V_{OPR\ MIN}$  = Minimum operational voltage level that ensures functionality as specified in Recommended Operating Conditions
- Ramp-up = start of a voltage supply transition time from off condition to  $V_{opr\ min}$ .
- Ramp-down = start of a voltage supply transition time from  $V_{opr}$  to off condition
- Supply\_ “n” = multiple instances of similar power supplies (i.e.  $VDDSHVn = VDDSHV0, VDDSHV1, VDDSHV2 \dots VDDSHV6$ )
- Supply\_ “xxx” = multiple instances of similar power supplies used for different signal types (i.e.  $VDDA\_1P8\_xxx = VDDA\_1P8\_DSITX, VDDA\_1P8\_USB, VDDA\_0P8\_DSITX, VDDA\_0P8\_USB, etc.$ )
- Time stamps = “T#” markers with descriptions and approximate elapsed times for general reference. Specific timing transitions are dependent upon PDN design (see PDN User Guide for details).

### 7.10.2.1 Power Supply Slew Rate Requirement

To maintain the safe operating range of the internal ESD protection devices, TI recommends limiting the maximum slew rate of supplies to be less than 100 mV/us, as shown in [图 7-2](#). For instance, a 1.8V supply should have a ramp time  $> 18 \mu s$  to ensure the slew rate  $< 100mV/us$ .

[图 7-2](#) describes the Power Supply Slew Rate Requirement in the device.

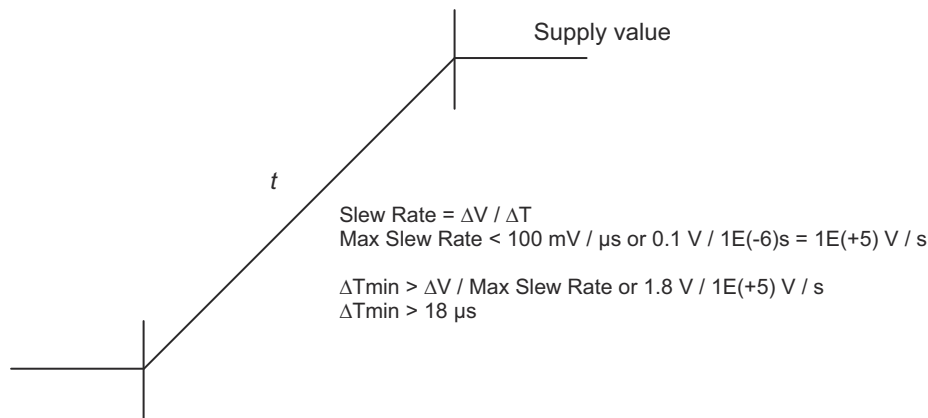

**图 7-2. Power Supply Slew and Slew Rate**

### 7.10.2.2 Combined MCU and Main Domains Power- Up Sequencing

节 7.10.2.2 describes the primary power-up sequencing when similar MCU and Main voltage domains are combined into common power rails. Combining MCU and Main voltage domains simplifies PDN design by reducing total number of power rails and sources while making MCU and Main processor sub-systems operational dependent on common power rails.

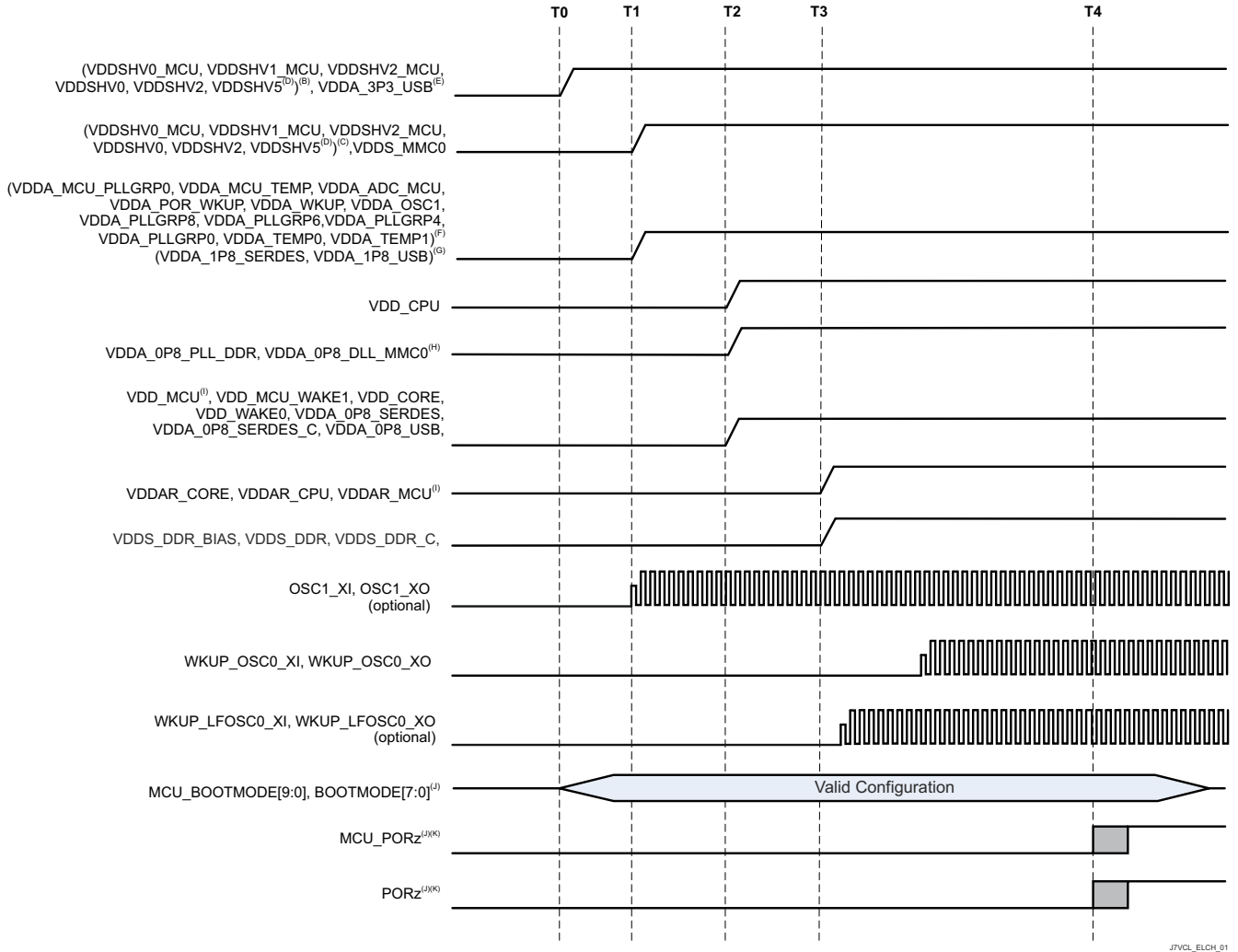

J7VCL\_ELCH\_01

- A. Time stamp markers:
- T0 - 3.3V voltages start ramp-up to  $V_{OPR\ MIN}$ . (0 ms)
  - T1 - 1.8-V voltages start ramp-up to  $V_{OPR\ MIN}$ . (2 ms)
  - T2 - Low voltage core supplies start ramp-up to  $V_{OPR\ MIN}$ . (3 ms)
  - T3 - Low voltage RAM array voltages start ramp-up to  $V_{OPR\ MIN}$ . (4 ms)
  - T4 - OSC1 is stable and PORz/MCU\_PORz are de-asserted to release processor from reset. (13 ms)
- B. Any MCU or Main dual voltage IO supplies (VDDSHVn\_MCU or VDDSHVn) being supplied by 3.3V to support 3.3V digital interfaces. A few supplies could have varying start times between T0 to T1 due to PDN designs using different power resources with varying turn-on & ramp-up time delays.
- C. Any MCU or Main dual voltage IO supplies (VDDSHVn\_MCU or VDDSHVn) being supplied by 1.8 V to support 1.8-V digital interfaces. When eMMC memories are used, Main 1.8-V supplies could have a ramp-up aligned to T3 due to PDN designs grouping supplies with VDD\_MMC0.
- D. VDDSHV5 supports MMC1 signaling for SD memory cards. If compliant high-speed SD card operation is needed, then an independent, dual voltage (3.3 V/1.8 V) power source and rail are required. The start of ramp-up to 3.3 V will be same as other 3.3-V domains as

- shown. If SD card is not needed or standard data rates with fixed 3.3 V operation is acceptable, then domain can be grouped with digital IO 3.3-V power rail. If a SD card is capable of operating with fixed 1.8 V, then domain can be grouped with digital IO 1.8-V power rail.
- E. VDDA\_3P3\_USB is 3.3-V analog domain used for USB 2.0 differential interface signaling. A low noise, analog supply is recommended to provide best signal integrity for USB data eye mask compliance. The start of ramp-up to 3.3 V will be same as other 3.3-V domains as shown. If USB interface is not needed or data bit errors can be tolerated, then domain can be grouped with 3.3-V digital IO power rail either directly or through a supply filter.
  - F. VDDA\_1P8\_<clk/pll/ana> are 1.8-V analog domains supporting clock oscillator, PLL and analog circuitry needing a low noise supply for optimal performance. It is not recommended to combine digital VDDSHVn\_MCU and VDDSHVn IO domains since high frequency switching noise could negatively impact jitter performance of clock, PLL and DLL signals. Combining analog VDDA\_1p8\_<phy> domains should be avoided but if grouped, then in-line ferrite bead supply filtering is required.
  - G. VDDA\_1P8\_<phy> are 1.8-V analog domains supporting multiple serial PHY interfaces. A low noise, analog supply is recommended to provide best signal integrity, interface performance and spec compliance. If any of these interfaces are not needed, data bit errors or non-compliant operation can be tolerated, then domains can be grouped with digital IO 1.8-V power rail either directly or through an in-line supply filter is allowed.
  - H. VDDA\_0P8\_<dll/pll> are 0.8-V analog domains supporting PLL and DLL circuitry needing a low noise supply for optimal performance. It is not recommended to combine these domains with any other 0.8-V domains since high frequency switching noise could negatively impact jitter performance of PLL and DLL signals.
  - I. VDD\_MCU is a digital voltage domain with a wide range enabling it to be grouped and ramped-up with either 0.8-V VDD\_CORE or 0.85-V RAM array (VDDAR\_xxx) domains.
  - J. Minimum set-up and hold times shown with respect to MCU\_PORz and PORz asserting high to latch MCU\_BOOTMODEn (referenced to MCU\_VDDSHV0) and BOOTMODEn (reference to VDDSHV2) settings into registers during power up sequence.
  - K. Minimum elapsed time from crystal oscillator circuitry being energized (VDDA\_OSC1 at T1) until stable clock frequency is reached depends upon on crystal oscillator, capacitor parameters and PCB parasitic values. A conservative 10 ms elapsed time defined by (T4 - T1) time stamps is shown. This could be reduced depending upon customer' s clock circuit (that is, crystal oscillator or clock generator) and PCB designs.

### 图 7-3. Combined MCU and Main Domains, Primary Power-Up Sequence

### 7.10.2.3 Combined MCU and Main Domains Power- Down Sequencing

图 7-4 describes the device power-down sequencing.

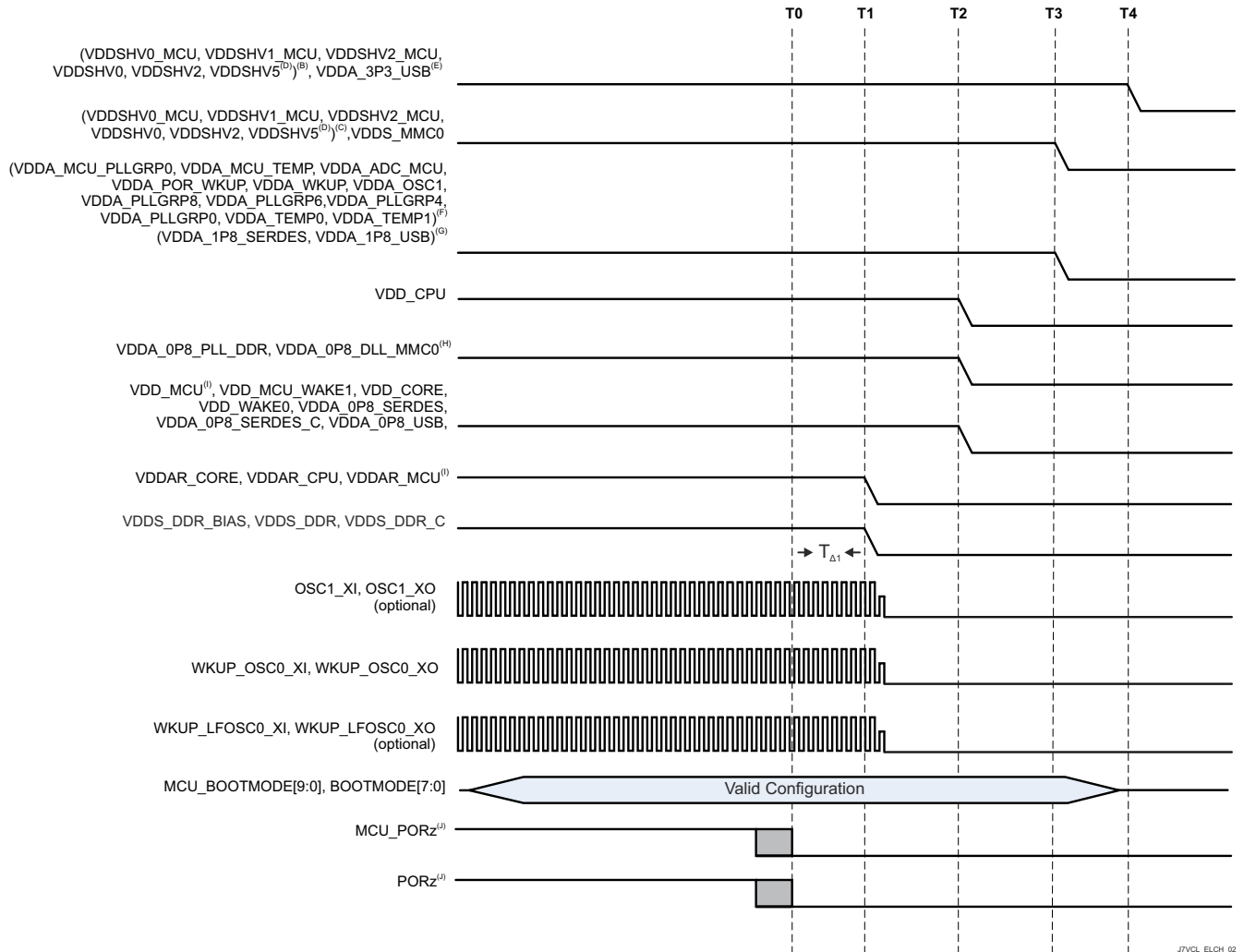

A. Time stamp markers:

- T0 - MCU\_PORz & PORz assert low to put all processor resources in safe state. (0 ms)
- T1 - Main DDR, SRAM Core, and SRAM CPU power supplies start ramp-down. (0.5 ms)
- T2 - Low voltage core supplies start supply ramp-down. (2.5 ms)
- T3 - 1.8-V voltages start supply ramp-down. (3.0 ms)
- T4 - 3.3V voltages start supply ramp-down. (3.5 ms)

- B. Any MCU or Main dual voltage IO domains (VDDSHVn\_MCU or VDDSHVn) being supplied by 3.3 V to support 3.3-V digital interfaces.
- C. Any MCU or Main dual voltage IO domains (VDDSHVn\_MCU or VDDSHVn) being supplied by 1.8 V to support 1.8-V digital interfaces.
- D. VDDSHV5 supports MMC1 signaling for SD memory cards. A dual voltage (3.3 V/1.8 V) power rail is required for compliant, high-speed SD card operations. If SD card is not needed or standard data rates with fixed 3.3-V operation is acceptable, then domain can be grouped with digital IO 3.3-V power rail. If a SD card is capable of operating with fixed 1.8 V, then domain can be grouped with digital IO 1.8-V power rail.
- E. VDDA\_3P3\_USB is 3.3-V analog domain used for USB 2.0 differential interface signaling. A low noise, analog supply is recommended to provide best signal integrity for USB data eye mask compliance. If USB interface is not needed or data bit errors can be tolerated, then domain can be grouped with 3.3-V digital IO power rail either directly or through a supply filter.
- F. VDDA\_1P8\_<clk/pll/ana> are 1.8V analog domains supporting clock oscillator, PLL and analog circuitry needing a low noise supply for optimal performance. It is not recommended to combine digital VDDSHVn\_MCU and VDDSHVn IO domains since high frequency

switching noise could negatively impact jitter performance of clock, PLL and DLL signals. Combining analog VDDA\_1p8\_<phy> domains should be avoided but if grouped, then in-line ferrite bead supply filtering is required .

- G. VDDA\_1P8\_<phy> are 1.8-V analog domains supporting multiple serial PHY interfaces. A low noise, analog supply is recommended to provide best signal integrity, interface performance and spec compliance. If any of these interfaces are not needed, data bit errors or non-compliant operation can be tolerated, then domains can be grouped with digital IO 1.8-V power rail either directly or through an in-line supply filter is allowed.
- H. VDDA\_0P8\_<dll/pll> are 0.8-V analog domains supporting PLL and DLL circuitry needing a low noise supply for optimal performance. It is not recommended to combine these domains with any other 0.8-V domains since high frequency switching noise could negatively impact jitter performance of PLL and DLL signals.
- I. VDD\_MCU is a digital voltage domain with a wide range enabling it to be grouped and ramped-up with either 0.8-V VDD\_CORE or 0.85-V RAM array (VDDAR\_<xxx>) domains.
- J. MCU\_PORz and PORz must be asserted low for  $T_{\Delta 1} = 200 \text{ us MIN}$  to ensure SoC resources enter into safe state before any voltage begins to ramp down.

#### 图 7-4. Combined MCU and Main Domains, Primary Power-Down Sequence

#### **7.10.2.4 Isolated MCU and Main Domains Power- Up Sequencing**

Isolated MCU and Main voltage domains enable an SoC's MCU and Main processor sub-systems to operate independently. There are 2 reasons an SoC's PDN design may need to support independent MCU and Main processor functionality. First is to provide flexibility to enable SoC low power modes that can significantly reduce SoC power dissipation when processor operations are not needed. Second is to enable robustness to gain freedom from interference (FFI) of a single fault impacting both MCU and Main processor sub-systems which is especially beneficial if using the SoC's MCU as the system safety monitoring processor. The number of additional PDN power rails needed is dependent upon number of different MCU IO signaling voltage levels. If only 1.8V IO signaling is used, then only 2 additional power rails could be required. If both 1.8 and 3.3V IO signaling is desired, then 4 additional power rails could be needed.

TDA4VE-Q1, TDA4AL-Q1, TDA4VL-Q1

ZHCSRF7A - DECEMBER 2022 - REVISED AUGUST 2023

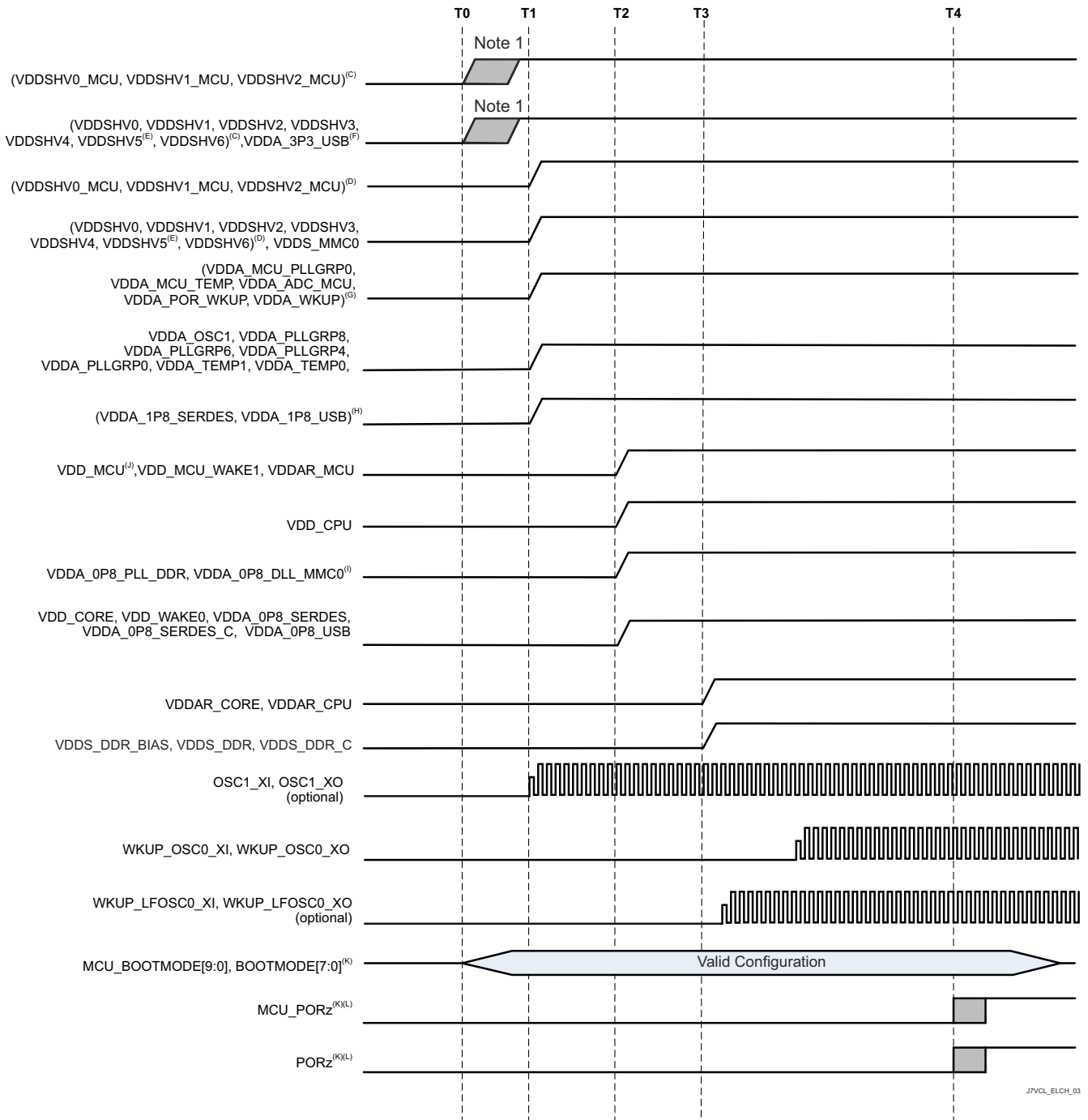

J7VCL\_ELCH\_03

A. T1 Time stamp markers:

- T0 - All 3.3-V voltages start supply ramp-up to  $V_{OPR\ MIN}$ . (0 ms)
- T1 - All 1.8-V voltages start supply ramp-up to  $V_{OPR\ MIN}$ . (2 ms)
- T2 - All core voltages start supply ramp-up to  $V_{OPR\ MIN}$ . (3 ms)
- T3 - All RAM array voltages start supply ramp-up to  $V_{OPR\ MIN}$ . (4 ms)
- T4 - OSC1 is stable and PORz/MCU\_PORz are de-asserted to release processor from reset. (13 ms)

B. Any MCU or Main dual voltage IO supplies (VDDSHVn\_MCU or VDDSHVn) being supplied by 3.3 V to support 3.3-V digital interfaces. A few supplies could have varying start times between T0 to T1 due to PDN designs using different power resources with varying turn-on & ramp-up time delays.

- C. Any MCU or Main dual voltage IO supplies (VDDSHVn\_MCU or VDDSHVn) being supplied by 1.8 V to support 1.8-V digital interfaces. When eMMC memories are used, Main 1.8-V supplies could have delayed start times that aligns to T3 due to PDN designs grouping supplies with VDD\_MMC0.
- D. VDDSHV5 supports MMC1 signaling for SD memory cards. If compliant UHS-I SD card operation is needed, then an independent, dual voltage (3.3 V/1.8 V) power source and rail are required. The start of ramp-up to 3.3 V will be same as other 3.3-V domains as shown. If SD card is not needed or standard data rates with fixed 3.3-V operation is acceptable, then supply can be grouped with digital IO 3.3-V power rail. If a SD card is capable of operating with fixed 1.8 V, then supply can be grouped with digital IO 1.8-V power rail.
- E. VDDA\_3P3\_USB is 3.3-V analog supply used for USB 2.0 differential interface signaling. A low noise, analog supply is recommended to provide best signal integrity for USB data eye mask compliance. The start of ramp-up to 3.3 V will be same as other 3.3-V domains as shown. If USB interface is not needed or data bit errors can be tolerated, then supply can be grouped with 3.3-V digital IO power rail either directly or through a supply filter.
- F. VDDA\_1P8\_<clk/pll/ana> are 1.8-V analog domains supporting clock oscillator, PLL and analog circuitry needing a low noise supply for optimal performance. It is not recommended to combine digital VDDSHVn\_MCU and VDDSHVn IO domains since high frequency switching noise could negatively impact jitter performance of clock, PLL and DLL signals. Combining analog VDDA\_1p8\_<phy> domains should be avoided but if grouped, then in-line ferrite bead supply filtering is required.
- G. VDDA\_1P8\_<phy> are 1.8-V analog domains supporting multiple serial PHY interfaces. A low noise, analog supply is recommended to provide best signal integrity, interface performance and spec compliance. If any of these interfaces are not needed, data bit errors or non-compliant operation can be tolerated, then domains can be grouped with digital IO 1.8-V power rail either directly or through an in-line supply filter is allowed.
- H. VDDA\_0P8\_<dll/pll> are 0.8-V analog domains supporting PLL and DLL circuitry needing a low noise supply for optimal performance. It is not recommended to combine these domains with any other 0.8-V domains since high frequency switching noise could negatively impact jitter performance of PLL and DLL signals.
- I. VDD\_MCU is a digital voltage supply with a wide operational voltage range and power sequencing flexibility, enabling it to be grouped and ramped-up with either 0.8-V VDD\_CORE at time stamp T2 or 0.85-V RAM array domains (VDDAR\_XXX) at time stamp T3.
- J. Minimum set-up and hold times shown with respect to MCU\_PORz and PORz asserting high to latch MCU\_BOOTMODEn (referenced to MCU\_VDDSHV0) and BOOTMODEn (reference to VDDSHV2) settings into registers during power up sequence.
- K. Minimum elapsed time from crystal oscillator circuitry being energized (VDDA\_OSC1 at T1) until stable clock frequency is reached depends upon on crystal oscillator, capacitor parameters and PCB parasitic values. A conservative 10 ms elapsed time defined by (T4 - T1) time stamps is shown. This could be reduced depending upon customer' s clock circuit (that is, crystal oscillator or clock generator) and PCB designs.

**图 7-5. Isolated MCU and Main Domains, Primary Power-Up Sequence**

### 7.10.2.5 Isolated MCU and Main Domains Power- Down Sequencing

图 7-6 describes the device power-down sequencing.

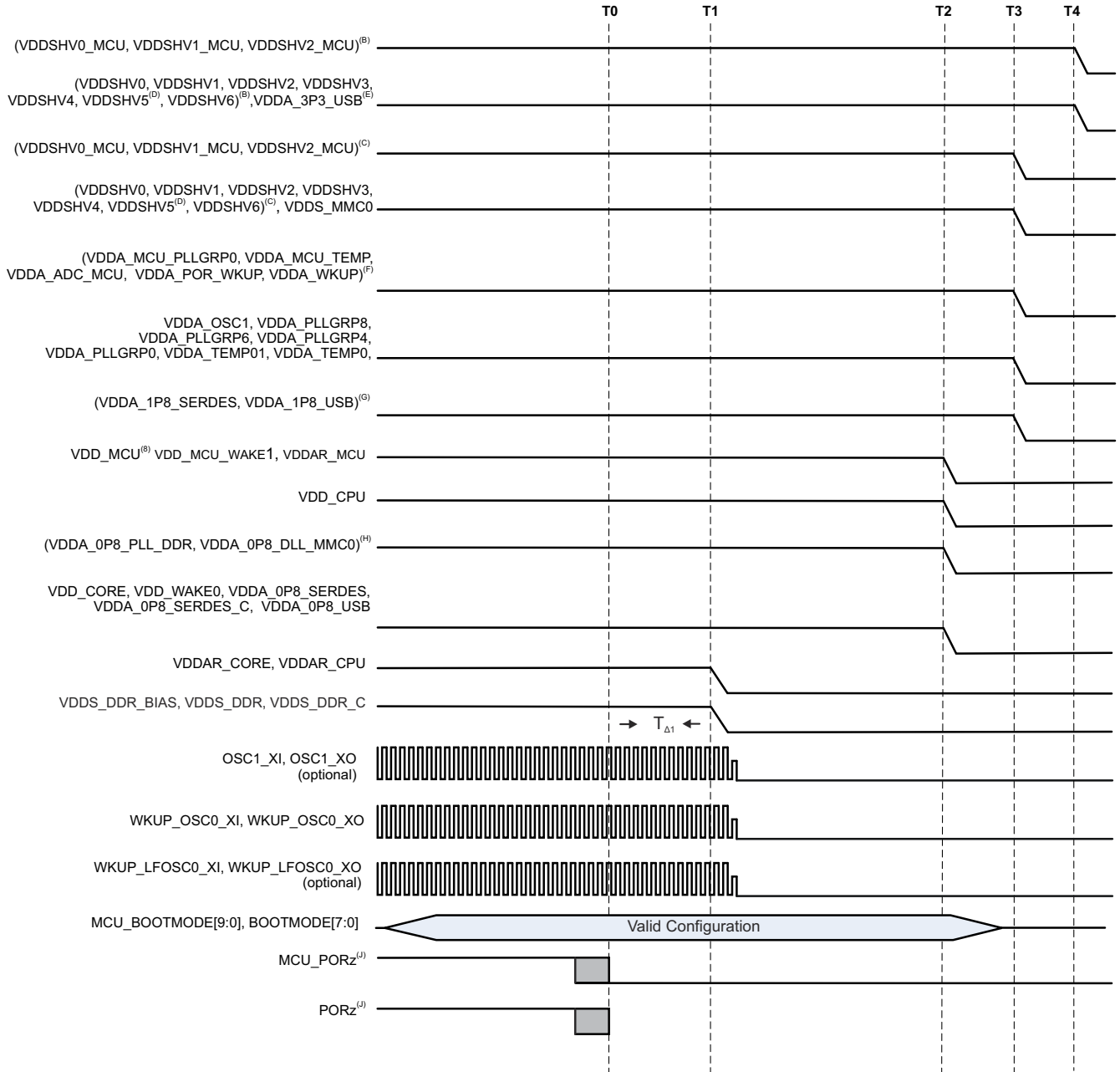

J7VCL\_ELCH\_04

A. Time stamp markers:

- T0 - MCU\_PORz and PORz assert low to put all processor resources in safe state. (0 ms)
- T1 - Main DDR, SRAM Core, and SRAM CPU power domains start ramp-down. (0.5 ms)
- T2 - All core voltages start supply ramp-down. (2.5 ms)
- T3 - All 1.8V voltages start supply ramp-down. (3.0 ms)
- T4 - All 3.3V voltages start supply ramp-down. (3.5 ms)

B. Any MCU or Main dual voltage IO domains (VDDSHVn\_MCU or VDDSHVn) being supplied by 3.3 V to support 3.3-V digital interfaces.

- C. Any MCU or Main dual voltage IO supplies (VDDSHVn\_MCU or VDDSHVn) being supplied by 1.8 V to support 1.8-V digital interfaces. When eMMC memories are used, Main 1.8-V supplies could have a ramp-down aligned to T1 due to PDN designs grouping supplies with VDD\_MMC0.
- D. VDDSHV5 supports MMC1 signaling for SD memory cards. A dual voltage (3.3 V/1.8 V) power rail is required for compliant, high-speed SD card operations. If compliant high-speed SD card operation is needed, then an independent, dual voltage (3.3 V/1.8 V) power source and rail are required. The start of ramp-down from 3.3 V/1.8 V will be same as other 3.3-V domains as shown. If SD card is not needed or standard data rates with fixed 3.3-V operation is acceptable, then domain can be grouped with digital IO 3.3-V power rail. If a SD card is capable of operating with fixed 1.8 V, then domain can be grouped with digital IO 1.8-V power rail.
- E. VDDA\_3P3\_USB is 3.3-V analog domain used for USB 2.0 differential interface signaling. A low noise, analog supply is recommended to provide best signal integrity for USB data eye mask compliance. The start of ramp-down from 3.3 V will be same as other 3.3-V domains as shown. If USB interface is not needed or data bit errors can be tolerated, then domain can be grouped with 3.3-V digital IO power rail either directly or through a supply filter.
- F. VDDA\_1P8\_<clk/pll/ana> are 1.8-V analog domains supporting clock oscillator, PLL and analog circuitry needing a low noise supply for optimal performance. It is not recommended to combine digital VDDSHVn\_MCU and VDDSHVn IO domains since high frequency switching noise could negatively impact jitter performance of clock, PLL and DLL signals. Combining analog VDDA\_1p8\_<phy> domains should be avoided but if grouped, then in-line ferrite bead supply filtering is required.
- G. VDDA\_1P8\_<phy> are 1.8-V analog domains supporting multiple serial PHY interfaces. A low noise, analog supply is recommended to provide best signal integrity, interface performance and spec compliance. If any of these interfaces are not needed, data bit errors or non-compliant operation can be tolerated, then domains can be grouped with digital IO 1.8-V power rail either directly or through an in-line supply filter is allowed.
- H. VDDA\_0P8\_<dll/pll> are 0.8-V analog domains supporting PLL and DLL circuitry needing a low noise supply for optimal performance. It is not recommended to combine these domains with any other 0.8-V domains since high frequency switching noise could negatively impact jitter performance of PLL and DLL signals.
- I. VDD\_MCU is a digital voltage domain with a wide range enabling it to be grouped and ramped-up with either 0.8-V VDD\_CORE or 0.85V RAM array (VDDAR\_xxx) domains.
- J. MCU\_PORz and PORz must be asserted low for  $T_{\Delta 1} = 200$  us MIN to ensure SoC resources enter into safe state before any voltage begins to ramp down.

**图 7-6. Isolated MCU and Main Domains, Primary Power- Down Sequencing**

#### **7.10.2.6 Independent MCU and Main Domains, Entry and Exit of MCU Only Sequencing**

Entry into MCU Only state is accomplished by executing a power down sequence except for the 4 MCU domains that remain energized. Exit from MCU Only state is accomplished by executing a power up sequence with the 4 MCU domains remaining energized throughout the sequ.



图 7-7. Independent MCU and Main Domains, Entry and Exit of MCU Only Sequencing

### 7.10.2.7 Independent MCU and Main Domains, Entry and Exit of DDR Retention State

Entry into DDR Retention state is accomplished by executing a power down sequence except for the 4 DDR domains that remain energized. Exit from DDR Retention state is accomplished by executing a power up sequence with the 3 DDR domains remaining energized throughout the sequence.

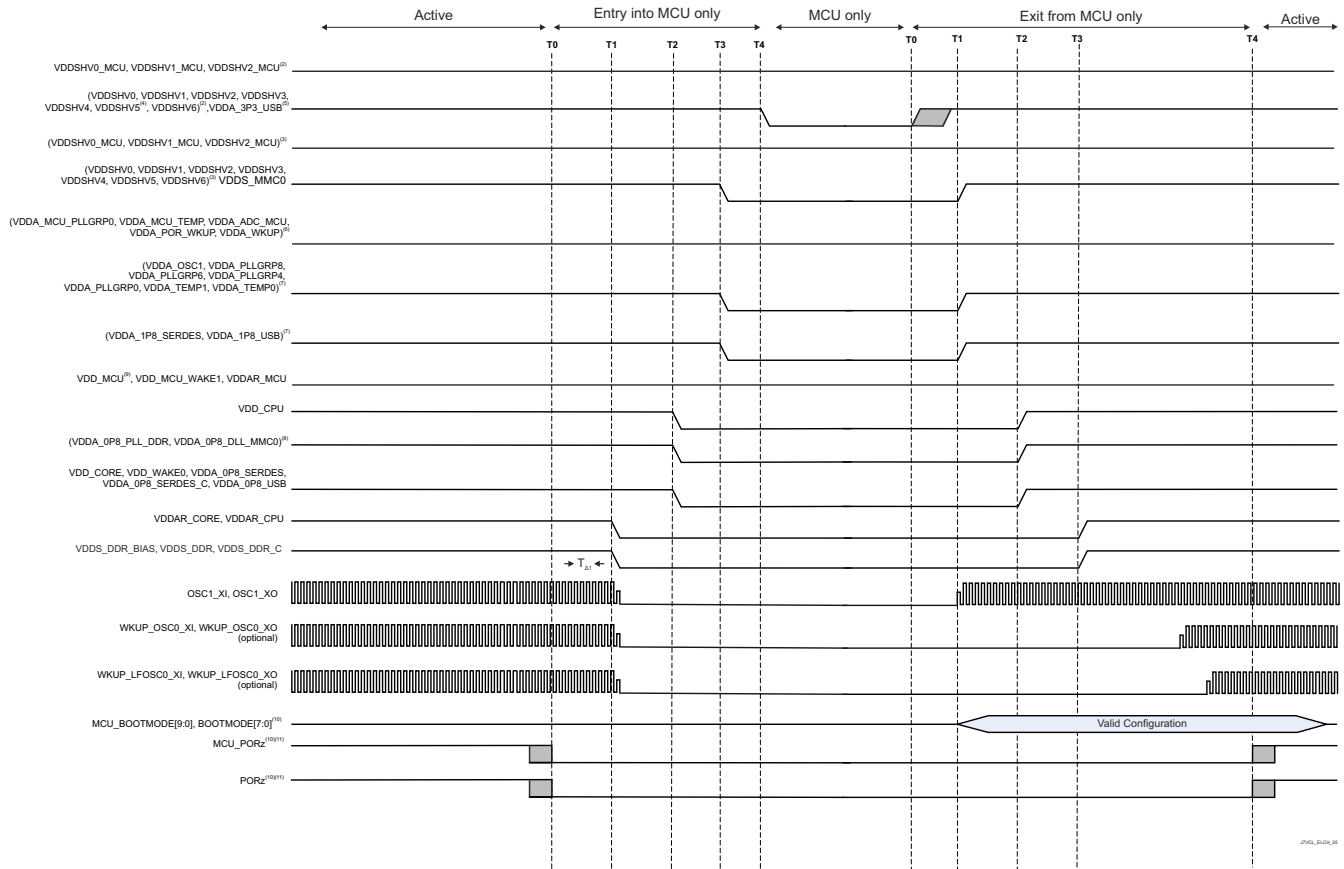
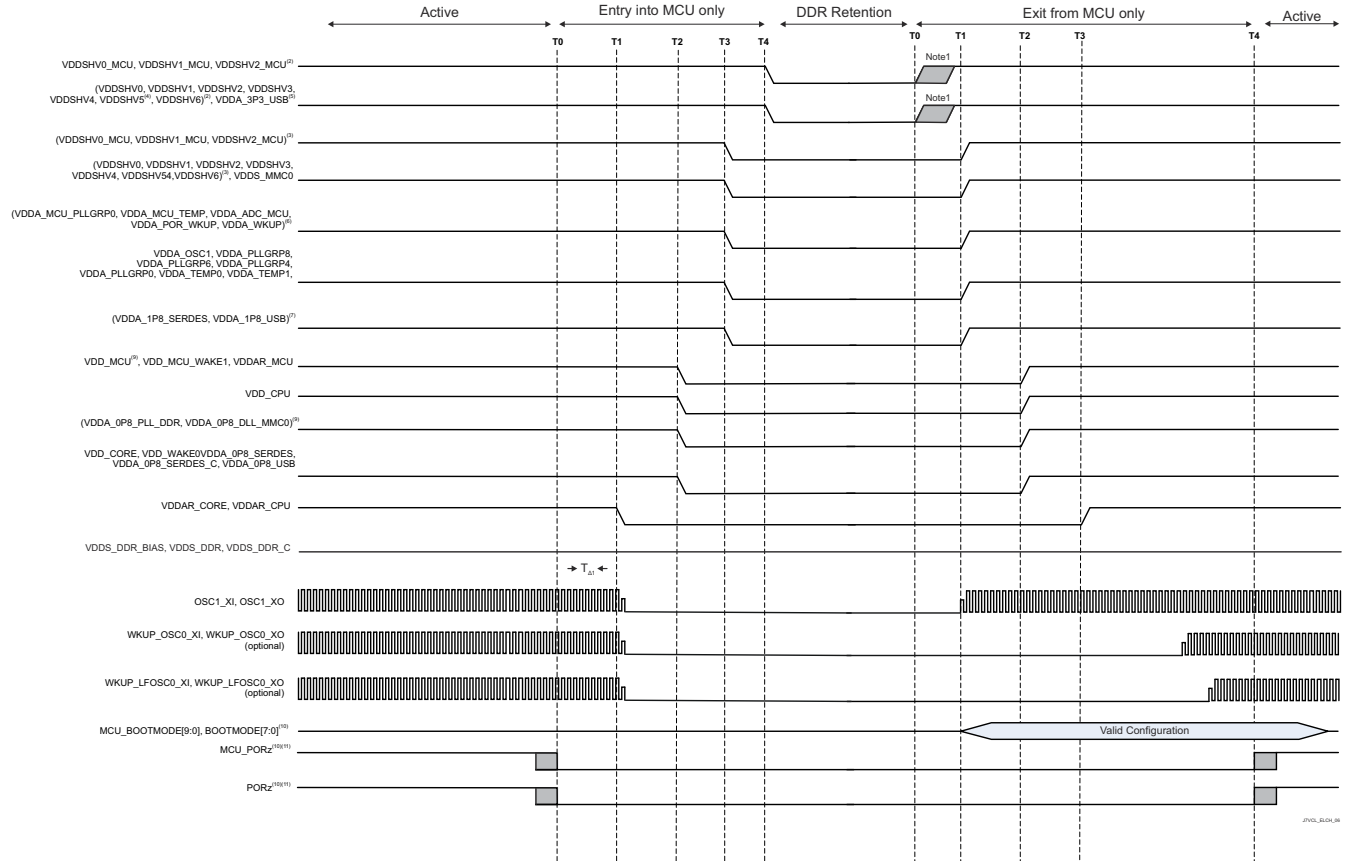

**图 7-8. Independent MCU and Main Domains, Entry and Exit of DDR Retention State**

### 7.10.2.8 Independent MCU and Main Domains, Entry and Exit of GPIO Retention Sequencing

Entry into GPIO Retention state is accomplished by executing a power down sequence except for the 2 or 4 wake domains that remain energized. Exit from GPIO Retention state is accomplished by executing a power up sequence with the 2 or 4 wake DDR domains remaining energized throughout the sequence.

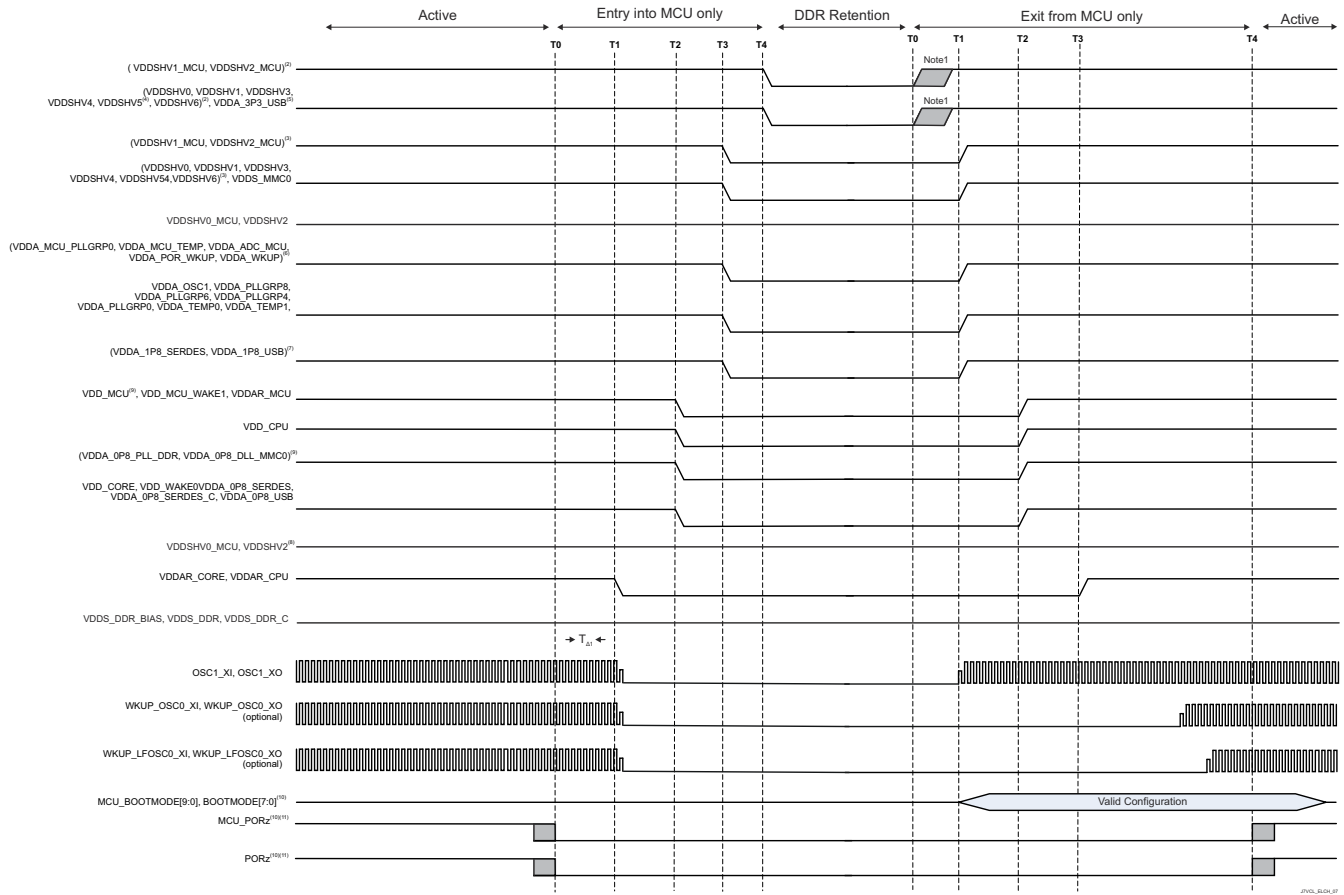

**图 7-9. Independent MCU and Main Domains, Entry and Exit of GPIO Retention Sequencing**

### 7.10.3 System Timing

For more details about features and additional description information on the subsystem multiplexing signals, see the corresponding sections within [Signal Descriptions](#) and [Detailed Description](#).

表 7-5. System Timing Conditions

PARAMETER		MIN	MAX	UNIT
<b>INPUT CONDITIONS</b>				
SR <sub>I</sub>	Input slew rate	0.5	2	V/ns
<b>OUTPUT CONDITIONS</b>				
C <sub>L</sub>	Output load capacitance	3	30	pF

#### 7.10.3.1 Reset Timing

The tables and figures provided in this section define the timing requirements and switching characteristics for reset related signals.

表 7-6. MCU\_PORz Timing Requirements

see 图 7-10

NO.		MIN	TYP	MAX	UNIT
RST1	Hold time, MCU_PORz active (low) at Power-up after all MCU DOMAIN supplies valid (using external crystal)	N + 1200 <sup>(2)</sup>	9500000		ns
RST2	t <sub>h</sub> (MCU_DOMAIN_SUPPLIES_VALID - MCU_PORz) Hold time, MCU_PORz active (low) at Power-up after all MCU DOMAIN supplies <sup>(1)</sup> valid and external clock stable (using external LVCMOS oscillator)	1200			ns
RST3	t <sub>w</sub> (MCU_PORzL) Pulse Width minimum, MCU_PORz low after Power-up (without removal of Power or system reference clock MCU_OSC0_XI/XO)	1200			ns

- (1) For the definition of the MCU DOMAIN supplies, see the 节 7.10.2.2, *Combined MCU and Main Domains Power-Up Sequencing*.  
 (2) N = oscillator start-up time



图 7-10. MCU\_PORz Timing Requirements

表 7-7. PORz Timing Requirements

see 图 7-11

NO.			MIN	MAX	UNIT
RST4	$t_{h(\text{MAIND\_SUPPLIES\_VALID} - \text{PORz})}$	Hold time, PORz active (low) at Power-up after all MAIN DOMAIN supplies <sup>(1)</sup> valid	1200		ns
RST5	$t_{w(\text{PORzL})}$	Pulse Width minimum, PORz low after Power-up	1200		ns

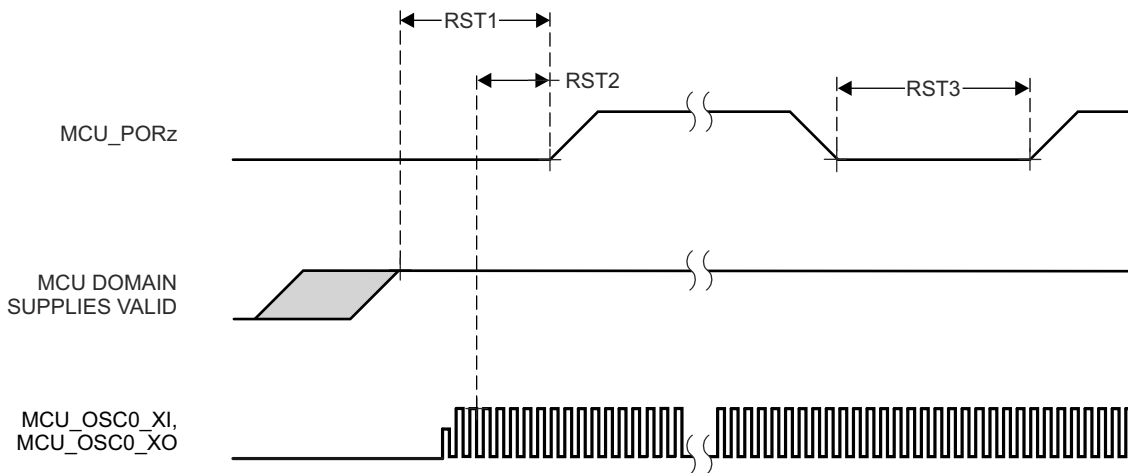
(1) For the definition of the MAIN DOMAIN supplies, see the 节 7.10.2.2, *Combined MCU and Main Domains Poewr-Up Sequencing*.

图 7-11. PORz Timing Requirements

表 7-8. MCU\_PORz initiates; MCU\_PORz\_OUT, PORz\_OUT, MCU\_RESETSTATz, and RESETSTATz Switching Characteristics

see 图 7-12

NO.	PARAMETER	MODE	MIN	MAX	UNIT
RST6	$t_{d(\text{MCU\_PORzL-MCU\_PORz\_OUTL})}$	Delay time, MCU_PORz active (low) to MCU_PORz_OUT active (low)	0		ns
RST7	$t_{d(\text{MCU\_PORzH-MCU\_PORz\_OUTH})}$	Delay time, MCU_PORz inactive (high) to MCU_PORz_OUT inactive (high)	0		ns
RST8	$t_{d(\text{MCU\_PORzL-PORz\_OUTL})}$	Delay time, MCU_PORz active (low) to PORz_OUT active (low)	0		ns
RST9	$t_{d(\text{MCU\_PORzH-PORz\_OUTH})}$	Delay time, MCU_PORz inactive (high) to PORz_OUT inactive (high)	1500		ns
RST10	$t_{d(\text{MCU\_PORzL-MCU\_RESETSTATzL})}$	Delay time, MCU_PORz active (low) to MCU_RESETSTATz active (low)	0		ns
RST11	$t_{d(\text{MCU\_PORzH-MCU\_RESETSTATzH})}$	Delay time, MCU_PORz inactive (high) to MCU_RESETSTATz inactive (high)	POST bypass	12000*S <sup>(1)</sup>	ns
RST12	$t_{d(\text{MCU\_PORzL-RESETSTATzL})}$	Delay time, MCU_PORz active (low) to RESETSTATz active (low)		0	ns
RST13	$t_{d(\text{MCU\_PORzH-RESETSTATzH})}$	Delay time, MCU_PORz inactive (high) to RESETSTATz inactive (high)		14500*S <sup>(1)</sup>	ns
RST14	$t_{w(\text{MCU\_PORz\_OUTL})}$	Pulse width minimum, MCU_PORz_OUT active (low)	1200		ns
RST15	$t_{w(\text{PORz\_OUTL})}$	Pulse Width Minimum PORz_OUT low	2550		ns
RST16	$t_{w(\text{MCU\_RESETSTATzL})}$	Pulse Width Minimum MCU_RESETSTATz low	3900*S <sup>(1)</sup>		ns
RST17	$t_{w(\text{RESETSTATzL})}$	Pulse Width Minimum RESETSTATz low	2650*S <sup>(1)</sup>		ns

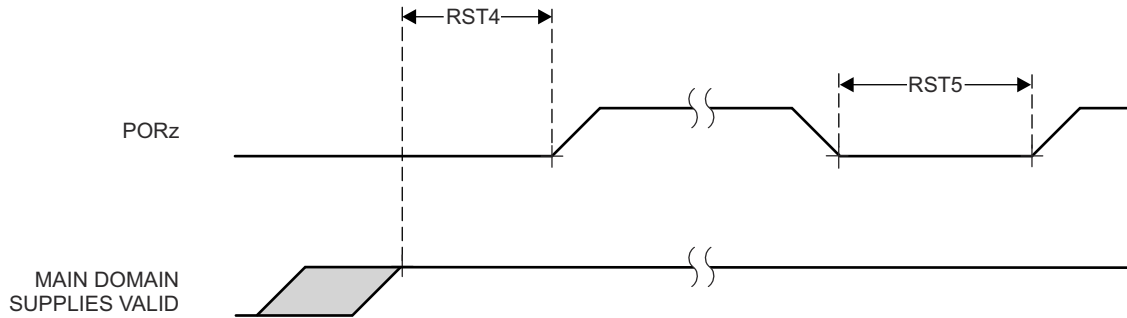
(1) S = MCU\_OSC0\_XI/XO clock period.

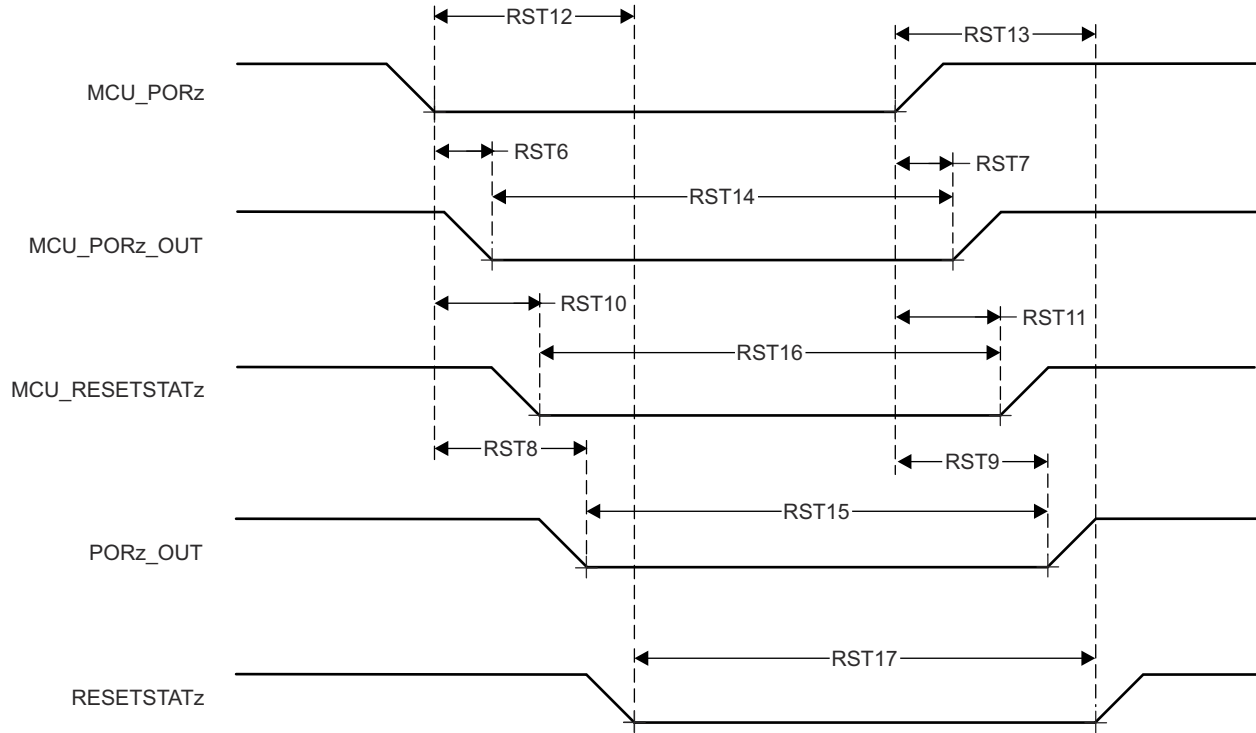

**图 7-12. MCU\_PORz initiates; MCU\_PORz\_OUT, PORz\_OUT, MCU\_RESETSTATz, and RESETSTATz Switching Characteristics**

**表 7-9. PORz Initiates; PORz\_OUT and RESETSTATz Switching Characteristics**

see 图 7-13

NO.	PARAMETER		MODE	MIN	MAX	UNIT
RST18	$t_{d(PORzL-PORz\_OUTL)}$	Delay time, PORz active (low) toPORz_OUT active (low)	software control of POR_RST_ISO_DONE_Z	$T^{(1)}$		
			CTRLMMR_WKUP_POR_RST_CTRL[0].POR_RST_ISO_DONE_Z = 0	0		ns
RST19	$t_{d(PORzH-PORz\_OUTH)}$	Delay time, PORz active (high) toPORz_OUT active (high)		1300		ns
RST20	$t_{d(PORzL-RESETSTATzL)}$	Delay time, PORz active (low) to RESETSTATz active (low)	software control of POR_RST_ISO_DONE_Z	$T^{(1)}$		
			CTRLMMR_WKUP_POR_RST_CTRL[0].POR_RST_ISO_DONE_Z = 0	0		ns
RST21	$t_{d(PORzH-RESETSTATzH)}$	Delay time, PORz active (high) to RESETSTATz active (high)		14500*S <sup>(2)</sup>		ns

- (1) T = Reset Isolation Time (Software Dependent).  
 (2) S = MCU\_OSC0\_XI/XO clock period.

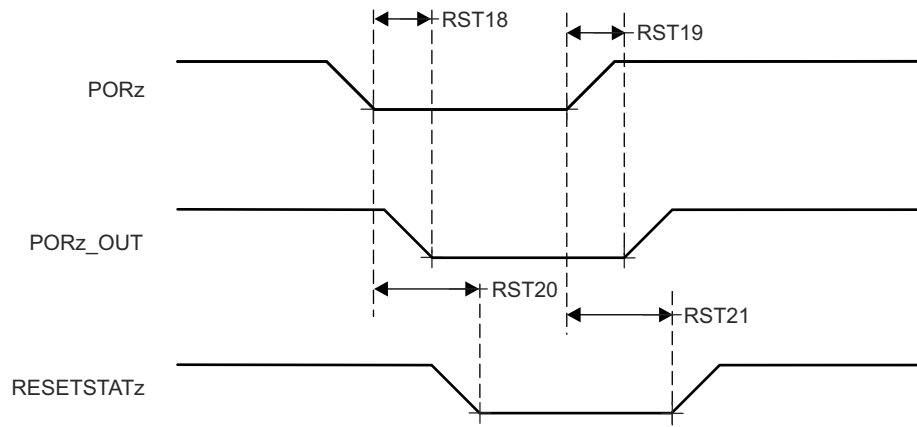

**图 7-13. PORz initiates; PORz\_OUT and RESETSTATz Switching Characteristics**

表 7-10. MCU\_RESETz Timing Requirements

see 图 7-14

NO.		MIN	MAX	UNIT
RST22	$t_{w(MCU\_RESETzL)}$ <sup>(1)</sup>	1200		ns

(1) Timing for MCU\_RESETz is valid only after all supplies are valid and MCU\_PORz has been asserted for the specified time.

表 7-11. MCU\_RESETz initiates; MCU\_RESETSTATz, and RESETSTATz Switching Characteristics

see 图 7-14

NO.	PARAMETER	MIN	MAX	UNIT
RST23	$t_{d(MCU\_RESETzL-MCU\_RESETSTATzL)}$	800		ns
RST24	$t_{d(MCU\_RESETzH-MCU\_RESETSTATzH)}$	3900*S <sup>(1)</sup>		ns
RST25	$t_{d(MCU\_RESETzL-RESETSTATzL)}$	800		ns
RST26	$t_{d(MCU\_RESETzH-RESETSTATzH)}$	3900*S <sup>(1)</sup>		ns

(1) S = MCU\_OSC0\_XI/XO clock period.



图 7-14. MCU\_RESETz initiates; MCU\_RESETSTATz, and RESETSTATz Timing Requirements and Switching Characteristics

**表 7-12. RESET\_REQz Timing Requirements**

see 图 7-15

NO.		MIN	MAX	UNIT
RST27	$t_{w(RES\bar{E}T\_REQzL)}$ <sup>(1)</sup> Pulse Width minimum, RESET_REQz active (low)	1200		ns

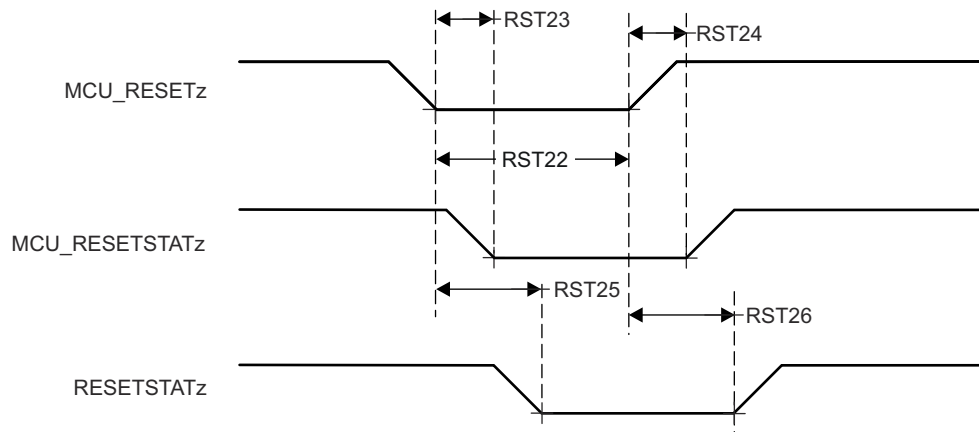
(1) Timing for RESET\_REQz is valid only after all supplies are valid and MCU\_PORz has been asserted for the specified time.

**表 7-13. RESET\_REQz initiates; RESETSTATz Switching Characteristics**

see 图 7-15

NO.	PARAMETER	MODE	MIN	MAX	UNIT
RST28	$t_{d(RES\bar{E}T\_REQzL-RES\bar{E}TSTATzL)}$ Delay time, RESET_REQz active (low) to RESETSTATz active (low)	software control of SOC_WARMRST_ISO_DONE_Z	T <sup>(1)</sup>		
		CTRLMMR_WKUP_MAIN_WARM_RST_CTRL[0].SOC_WARMRST_ISO_DONE_Z = 0	740		ns
RST29	$t_{d(RES\bar{E}T\_REQzH-RES\bar{E}TSTATzH)}$ Delay time, RESET_REQz inactive (high) to RESETSTATz inactive (high)		2650*S <sup>(2)</sup>		ns

- (1) T = Reset Isolation Time (Software Dependent).
- (2) S = MCU\_OSC0\_XI/XO clock period.

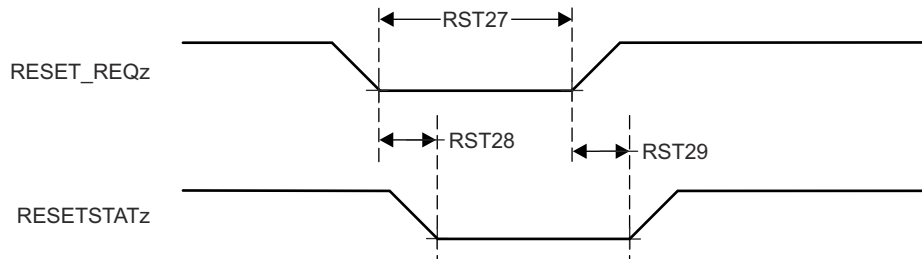

**图 7-15. RESET\_REQz initiates; RESETSTATz Timing Requirements and Switching Characteristics**

表 7-14. EMUx Timing Requirements

see 图 7-16

NO.			MIN	MAX	UNIT
RST30	$t_{su}(EMUx-MCU\_PORz)$	Setup time, EMU[1:0] before MCU_PORz inactive (high)	$3 \cdot S^{(1)}$		ns
RST31	$t_h(MCU\_PORz - EMUx)$	Hold time, EMU[1:0] after MCU_PORz inactive (high)	10		ns

(1) S = MCU\_OSC0\_XI/XO clock period.



图 7-16. EMUx Timing Requirements

表 7-15. MCU\_BOOTMODE Timing Requirements

see 图 7-17

NO.			MIN	MAX	UNIT
RST32	$t_{su}(MCU\_BOOTMODE-MCU\_PORz\_OUT)$	Setup time, MCU_BOOTMODE[09:00] before MCU_PORz_OUT high	$3 \cdot S^{(1)}$		ns
RST33	$t_h(MCU\_PORz\_OUT - MCU\_BOOTMODE)$	Hold time, MCU_BOOTMODE[09:00] after MCU_PORz_OUT high	0		ns

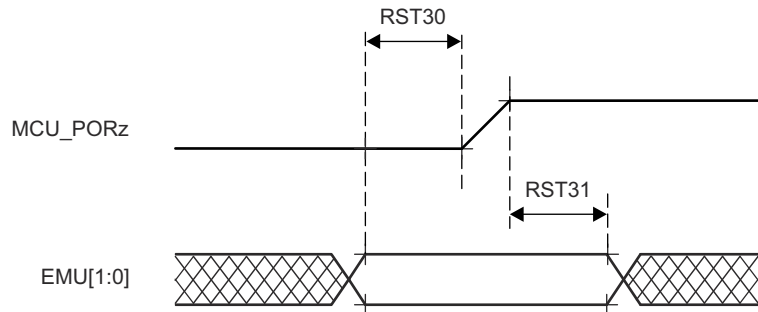
(1) S = MCU\_OSC0\_XI/XO clock period.



图 7-17. MCU\_BOOTMODE Timing Requirements

**表 7-16. BOOTMODE Timing Requirements**

see [图 7-18](#)

NO.			MIN	MAX	UNIT
RST34	$t_{su}(\text{BOOTMODE}-\text{PORz\_OUT})$	Setup time, BOOTMODE[7:0] before PORz_OUT high	$3 \cdot S^{(1)}$		ns
RST35	$t_h(\text{PORz\_OUT} - \text{BOOTMODE})$	Hold time, BOOTMODE[7:0] after PORz_OUT high	0		ns

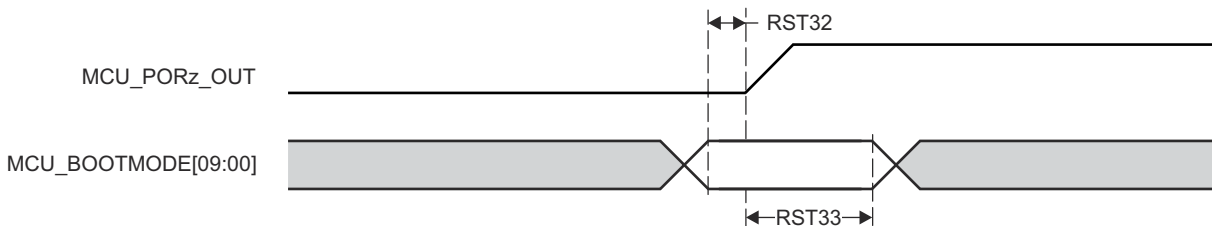
(1) S = MCU\_OSC0\_XI/XO clock period.

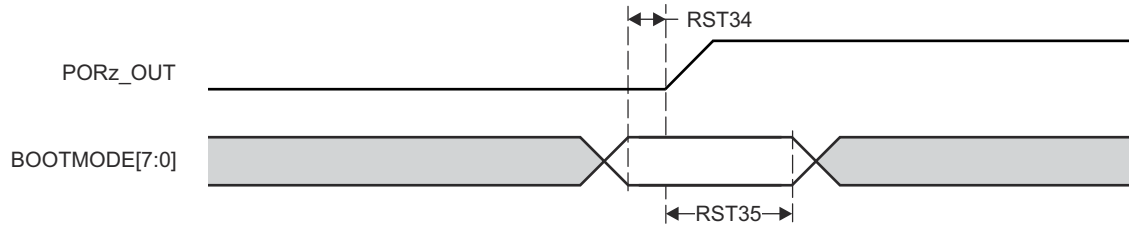

**图 7-18. BOOTMODE Timing Requirements**

### 7.10.3.2 Safety Signal Timing

Tables and figures provided in this section define switching characteristics for MCU\_SAFETY\_ERRORn and SOC\_SAFETY\_ERRORn.

表 7-17. MCU\_SAFETY\_ERRORn Switching Characteristics

see 图 7-19

NO.	PARAMETER	MIN	MAX	UNIT
SFTY1	$t_{w(MCU\_SAFETY\_ERRORn)}$ Pulse width minimum, MCU_SAFETY_ERRORn active (PWM mode disabled)	$P \cdot R^{(1) (2)}$		ns
SFTY2	$t_{d(ERROR\_CONDITION-MCU\_SAFETY\_ERRORnL)}$ Delay time, ERROR CONDITION to MCU_SAFETY_ERRORn active	$50 \cdot P^{(1)}$		ns

- (1) P = ESM functional clock (MCU\_SYSCCLK0 /6).  
(2) R = Error Pin Counter Pre-Load Register count value.



图 7-19. MCU\_SAFETY\_ERRORn Switching Characteristics

表 7-18. SOC\_SAFETY\_ERRORn Switching Characteristics

see 图 7-20

NO.	PARAMETER	MIN	MAX	UNIT
SFTY3	$t_{w(SOC\_SAFETY\_ERRORn)}$ Pulse width minimum, SOC_SAFETY_ERRORn active (PWM mode disabled)	$P \cdot R^{(1) (2)}$		ns
SFTY4	$t_{d(ERROR\_CONDITION-SOC\_SAFETY\_ERRORnL)}$ Delay time, ERROR CONDITION to SOC_SAFETY_ERRORn active	$50 \cdot P^{(1)}$		ns

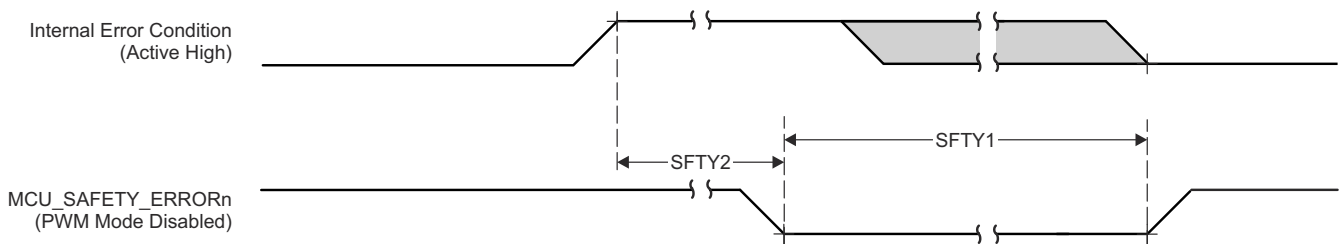

图 7-20. SOC\_SAFETY\_ERRORn Switching Characteristics

### 7.10.3.3 Clock Timing

Tables and figures provided in this section define timing requirements and switching characteristics for clock signals.

表 7-19. Clock Timng Requiements

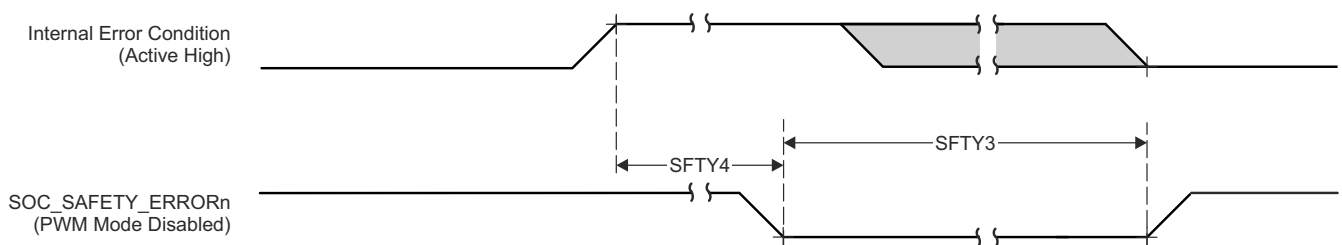
see 图 7-21

NO.			MIN	MAX	UNIT
CLK1	$t_{c}(EXT\_REFCLK1)$	Cycle time minimum, EXT_REFCLK1	10		ns
CLK2	$t_{w}(EXT\_REFCLK1H)$	Pulse Duration minimum, EXT_REFCLK1 high	$E*0.45^{(1)}$	$E*0.55^{(1)}$	ns
CLK3	$t_{w}(EXT\_REFCLK1L)$	Pulse Duration minimum, EXT_REFCLK1 low	$E*0.45^{(1)}$	$E*0.55^{(1)}$	ns

(1) E = EXT\_REFCLK1 cycle time.



图 7-21. Clock Timing Requirements

表 7-20. Clock Switching Characteristics

see 图 7-22

NO.	PARAMETER		MIN	MAX	UNIT
CLK4	$t_{c}(SYSCLKOUT0)$	Cycle time minimum, SYSCLKOUT0	8		ns
CLK5	$t_{w}(SYSCLKOUT0H)$	Pulse Duration minimum, SYSCLKOUT0 high	$A*0.4^{(1)}$	$A*0.6^{(1)}$	ns
CLK6	$t_{w}(SYSCLKOUT0L)$	Pulse Duration minimum, SYSCLKOUT0 low	$A*0.4^{(1)}$	$A*0.6^{(1)}$	ns
CLK7	$t_{c}(OBSCLK0)$	Cycle time minimum, OBSCLK0	5		ns
CLK8	$t_{w}(OBSCLK0H)$	Pulse Duration minimum, OBSCLK0 high	$B*0.4^{(2)}$	$B*0.6^{(2)}$	ns
CLK9	$t_{w}(OBSCLK0L)$	Pulse Duration minimum, OBSCLK0 low	$B*0.4^{(2)}$	$B*0.6^{(2)}$	ns
CLK10	$t_{c}(CLKOUT0)$	Cycle time minimum, CLKOUT0	20		ns
CLK11	$t_{w}(CLKOUT0H)$	Pulse Duration minimum, CLKOUT0 high	$C*0.4^{(3)}$	$C*0.6^{(3)}$	ns
CLK12	$t_{w}(CLKOUT0L)$	Pulse Duration minimum, CLKOUT0 low	$C*0.4^{(3)}$	$C*0.6^{(3)}$	ns

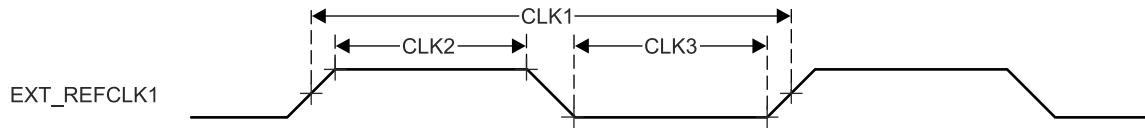
(1) A = SYSCLKOUT0 cycle time.

(2) B = OBSCLK0 cycle time.

(3) C = CLKOUT0 cycle time.



图 7-22. Clock Switching Characteristics

## 7.10.4 Clock Specifications

### 7.10.4.1 Input and Output Clocks / Oscillators

Various external clock inputs/outputs are needed to drive the device. Summary of these input clock signals is as follows:

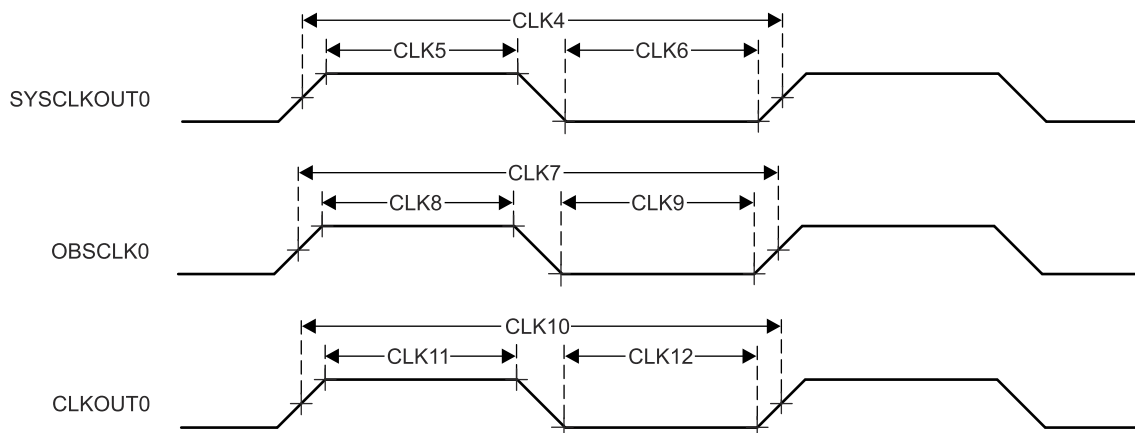
- High frequency oscillators inputs
  - OSC1\_XO/OSC1\_XI — external main crystal interface pins connected to internal oscillator which sources reference clock. Provides reference clock to PLLs within MCU domain and MAIN domain. This high-frequency oscillator is used to provide audio clock frequencies to MCASPs.
  - WKUP\_OSC0\_XO/WKUP\_OSC0\_XI — external main crystal interface pins connected to internal oscillator which sources reference clock. Provides reference clock to PLLs within WKUP and MAIN domain.
- Low frequency digital input
  - WKUP\_LF\_CLKIN - Low Frequency 32k digital clock input, optionally sourced from an external PMIC or other clock source. This SoC does not support a LFOSC crystal input.
- General purpose clock inputs
  - MCU\_EXT\_REFCLK0 - optional external System clock input (MCU domain).
  - EXT\_REFCLK1 — optional external System clock input (MAIN domain).
- Peripheral clocks - refer to the Signal Descriptions for peripheral specific clocks

For more information about Input clock interfaces, see *Clocking* section in *Device Configuration* chapter in the device TRM.

#### 7.10.4.1.1 WKUP\_OSC0 Internal Oscillator Clock Source

图 7-23 shows the recommended crystal circuit. All discrete components used to implement the oscillator circuit should be placed as close as possible to the WKUP\_OSC0\_XI and WKUP\_OSC0\_XO pins.



图 7-23. WKUP\_OSC0 Crystal Implementation

The crystal must be in the fundamental mode of operation and parallel resonant. 表 7-21 summarizes the required electrical constraints.

表 7-21. WKUP\_OSC0 Crystal Electrical Characteristics

PARAMETER		MIN	TYP	MAX	UNIT
$F_{xtal}$	Crystal Parallel Resonance Frequency	19.2, 20, 24, 25, 26, 27			MHz

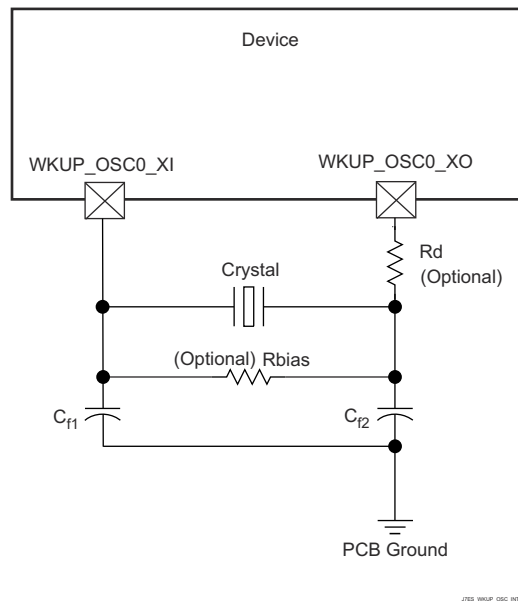
表 7-21. WKUP\_OSC0 Crystal Electrical Characteristics (continued)

PARAMETER		MIN	TYP	MAX	UNIT
F <sub>xtal</sub>	Crystal Frequency Stability and Tolerance	Ethernet RGMII and RMII not used		±100	ppm
		Ethernet RGMII and RMII using derived clock		±50	
C <sub>L1+PCBXI</sub>	Capacitance of C <sub>L1</sub> + C <sub>PCBXI</sub>	12		24	pF
C <sub>L2+PCBXO</sub>	Capacitance of C <sub>L2</sub> + C <sub>PCBXO</sub>	12		24	pF
C <sub>L</sub>	Crystal Load Capacitance	6		12	pF
C <sub>shunt</sub>	Crystal Circuit Shunt Capacitance	ESR <sub>xtal</sub> = 30 Ω	19.2 MHz, 20 MHz, 24 MHz, 25 MHz, 26 MHz, 27 MHz	7	pF
		ESR <sub>xtal</sub> = 40 Ω	19.2 MHz, 20 MHz, 24 MHz, 25 MHz, 26 MHz, 27 MHz	5	pF
		ESR <sub>xtal</sub> = 50 Ω	19.2 MHz, 20 MHz, 24 MHz, 25 MHz, 26 MHz, 27 MHz	5	pF
		ESR <sub>xtal</sub> = 60 Ω	19.2 MHz, 20 MHz, 24 MHz	5	pF
		ESR <sub>xtal</sub> = 80 Ω	19.2 MHz, 20 MHz	5	pF
			25 MHz	3	pF
ESR <sub>xtal</sub> = 100 Ω	19.2 MHz, 20 MHz	3	pF		
ESR <sub>xtal</sub>	Crystal Effective Series Resistance			100	Ω

When selecting a crystal, the system design must consider the temperature and aging characteristics of a based on the worst case environment and expected life expectancy of the system.

表 7-22 details the switching characteristics of the oscillator and the requirements of the input clock.

表 7-22. WKUP\_OSC0 Switching Characteristics - Crystal Mode

PARAMETER		MIN	TYP	MAX	UNIT
C <sub>XI</sub>	XI Capacitance			1.55	pF
C <sub>XO</sub>	XO Capacitance			1.35	pF
C <sub>XIXO</sub>	XI to XO Mutual Capacitance			0.9	fF
t <sub>s</sub>	Maximum Start-up Time		9.5 <sup>(1)</sup>		ms

- (1) TI strongly encourages each customer to submit samples of the device to the resonator/crystal vendors for validation. The vendors are equipped to determine what load capacitors will best tune their resonator/crystal to the microcontroller device for optimum startup and operation over temperature/voltage extremes.



图 7-24. WKUP\_OSC0 Start-up Time

#### 7.10.4.1.1.1 Load Capacitance

The crystal circuit must be designed such that it applies the appropriate capacitive load to the crystal, as defined by the crystal manufacturer. The capacitive load,  $C_L$ , of this circuit is a combination of discrete capacitors  $C_{L1}$ ,  $C_{L2}$ , and several parasitic contributions. PCB signal traces which connect crystal circuit components to WKUP\_OSC0\_XI and WKUP\_OSC0\_XO have parasitic capacitance to ground,  $C_{PCBXI}$  and  $C_{PCBXO}$ , where the PCB designer should be able to extract parasitic capacitance for each signal trace. The WKUP\_OSC0 circuits and device package have combined parasitic capacitance to ground,  $C_{PCBXI}$  and  $C_{PCBXO}$ , where these parasitic capacitance values are defined in 表 7-22.

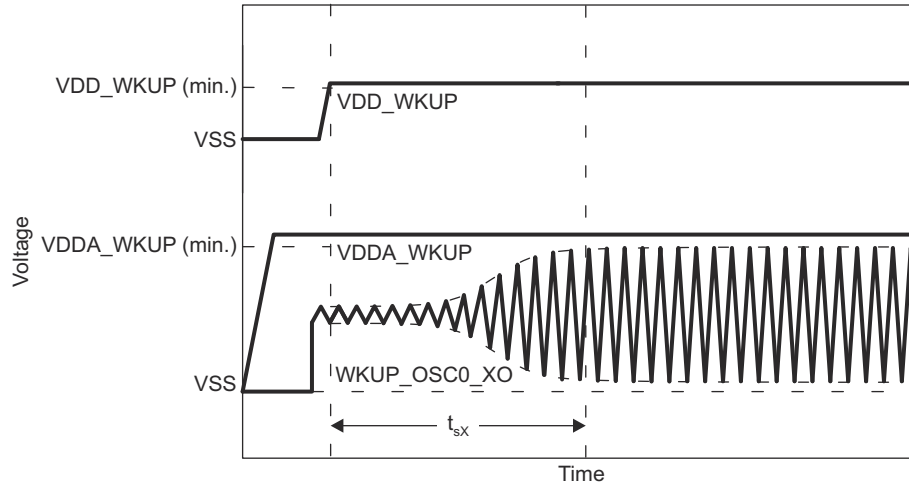

图 7-25. Load Capacitance

Load capacitors,  $C_{L1}$  and  $C_{L2}$  in 图 7-23, should be chosen such that the below equation is satisfied.  $C_L$  in the equation is the load specified by the crystal manufacturer.

$$C_L = [(C_{L1} + C_{PCBXI} + C_{XI}) \times (C_{L2} + C_{PCBXO} + C_{XO})] / [(C_{L1} + C_{PCBXI} + C_{XI}) + (C_{L2} + C_{PCBXO} + C_{XO})]$$

To determine the value of  $C_{L1}$  and  $C_{L2}$ , multiply the capacitive load value  $C_L$  by 2. Using this result, subtract the combined values of  $C_{PCBXI} + C_{XI}$  to determine the value of  $C_{L1}$  and the combined values of  $C_{PCBXO} + C_{XO}$  to determine the value of  $C_{L2}$ . For example, if  $C_L = 10$  pF,  $C_{PCBXI} = 2.9$  pF,  $C_{XI} = 0.5$  pF,  $C_{PCBXO} = 3.7$  pF,  $C_{XO} = 0.5$  pF, the value of  $C_{L1} = [(2C_L) - (C_{PCBXI} + C_{XI})] = [(2 \times 10 \text{ pF}) - 2.9 \text{ pF} - 0.5 \text{ pF}] = 16.6$  pF and  $C_{L2} = [(2C_L) - (C_{PCBXO} + C_{XO})] = [(2 \times 10 \text{ pF}) - 3.7 \text{ pF} - 0.5 \text{ pF}] = 15.8$  pF

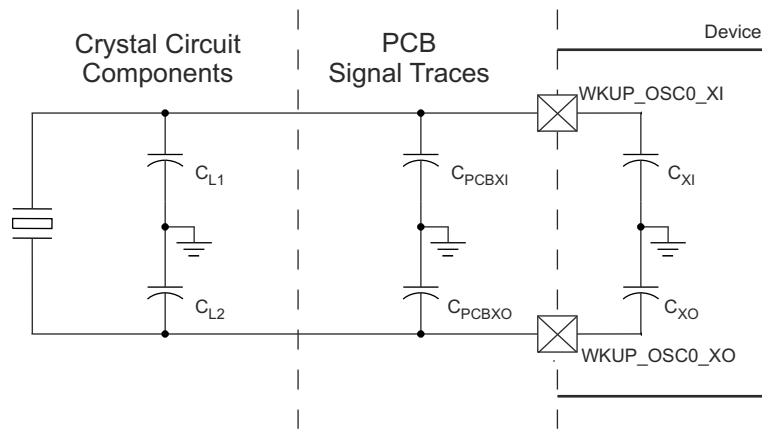
### 7.10.4.1.1.2 Shunt Capacitance

The crystal circuit must also be designed such that it does not exceed the maximum shunt capacitance for WKUP\_OSC0 operating conditions defined in 表 7-21. Shunt capacitance,  $C_{shunt}$ , of the crystal circuit is a combination of crystal shunt capacitance and parasitic contributions. PCB signal traces which connect crystal circuit components to WKUP\_OSC0 have mutual parasitic capacitance to each other,  $C_{PCBXIXO}$ , where the PCB designer should be able to extract mutual parasitic capacitance between these signal traces. The device package also has mutual parasitic capacitance,  $C_{XIXO}$ , where this mutual parasitic capacitance value is defined in 表 7-22.

PCB routing should be designed to minimize mutual capacitance between XI and XO signal traces. This is typically done by keeping signal traces short and not routing them in close proximity. Mutual capacitance can also be minimized by placing a ground trace between these signals when the layout requires them to be routed in close proximity. It is important to minimize the mutual capacitance on the PCB to provide as much margin as possible when selecting a crystal.



图 7-26. Shunt Capacitance

A crystal should be chosen such that the below equation is satisfied.  $C_0$  in the equation is the maximum shunt capacitance specified by the crystal manufacturer.

$$C_{shunt} \geq C_0 + C_{PCBXIXO} + C_{XIXO}$$

For example, the equation would be satisfied when the crystal being used is 25 MHz with an ESR = 30  $\Omega$ ,  $C_{PCBXIXO} = 0.04$  pF,  $C_{XIXO} = 0.01$  pF, and shunt capacitance of the crystal is less than or equal to 6.95 pF.

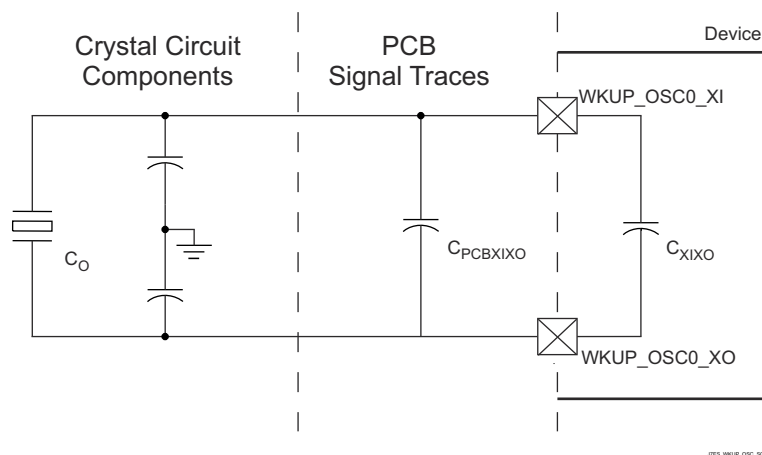
### 7.10.4.1.2 WKUP\_OSC0 LVC MOS Digital Clock Source

图 7-27 shows the recommended oscillator connections when WKUP\_OSC0\_XI is connected to a 1.8-V LVC MOS square-wave digital clock source.

#### 备注

A DC steady-state condition is not allowed on WKUP\_OSC0\_XI when the oscillator is powered up. This is not allowed because WKUP\_OSC0\_XI is internally AC coupled to a comparator that may enter a unknown state when DC is applied to the input. Therefore, application software should power down WKUP\_OSC0 any time WKUP\_OSC0\_XI is not toggling between logic states.



图 7-27. 1.8-V LVCMOS-Compatible Clock Input

#### 7.10.4.1.3 Auxiliary OSC1 Internal Oscillator Clock Source

图 7-28 shows the recommended crystal circuit. All discrete components used to implement the oscillator circuit should be placed as close as possible to the OSC1\_XI and OSC1\_XO pins.

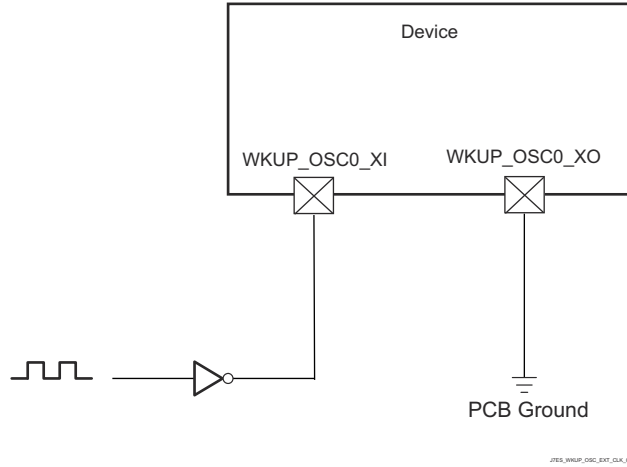

图 7-28. OSC1 Crystal Implementation

The crystal must be in the fundamental mode of operation and parallel resonant. 表 7-23 summarizes the required electrical constraints.

**表 7-23. OSC1 Crystal Electrical Characteristics**

PARAMETER		MIN	TYP	MAX	UNIT
$F_{xtal}$	Crystal Parallel Resonance Frequency	19.2		27	MHz
$F_{xtal}$	Crystal Frequency Stability and Tolerance	Ethernet RGMII and RMII not used		$\pm 100$	ppm
		Ethernet RGMII and RMII using derived clock		$\pm 50$	
$C_{L1+PCBXI}$	Capacitance of $C_{L1} + C_{PCBXI}$	12		24	pF
$C_{L2+PCBXO}$	Capacitance of $C_{L2} + C_{PCBXO}$	12		24	pF
$C_L$	Crystal Load Capacitance	6		12	pF
$C_{shunt}$	Crystal Circuit Shunt Capacitance	$ESR_{xtal} = 30 \Omega$	19.2 MHz, 20 MHz, 24 MHz, 25 MHz, 26 MHz, 27 MHz	7	pF
		$ESR_{xtal} = 40 \Omega$	19.2 MHz, 20 MHz, 24 MHz, 25 MHz, 26 MHz, 27 MHz	5	pF
		$ESR_{xtal} = 50 \Omega$	19.2 MHz, 20 MHz, 24 MHz, 25 MHz, 26 MHz, 27 MHz	5	pF
		$ESR_{xtal} = 60 \Omega$	19.2 MHz, 20 MHz, 24 MHz	5	pF
		$ESR_{xtal} = 80 \Omega$	19.2 MHz, 20 MHz	5	pF
			25 MHz	3	pF
$ESR_{xtal} = 100 \Omega$	19.2 MHz, 20 MHz	3	pF		
$ESR_{xtal}$	Crystal Effective Series Resistance			100	$\Omega$

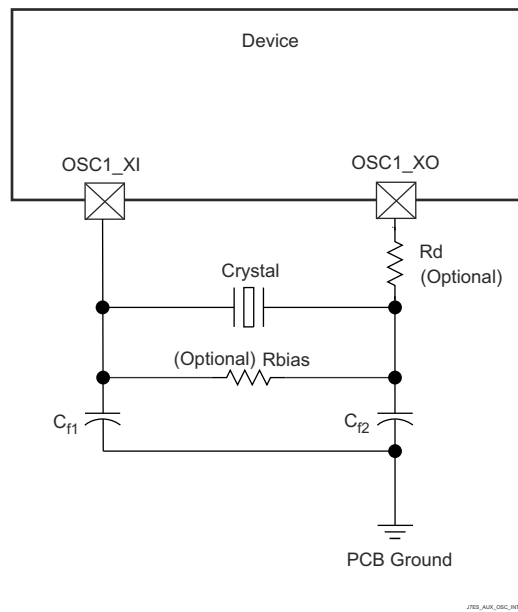
When selecting a crystal, the system design must consider the temperature and aging characteristics of a based on the worst case environment and expected life expectancy of the system.

表 7-24 details the switching characteristics of the oscillator and the requirements of the input clock.

**表 7-24. OSC1 Switching Characteristics - Crystal Mode**

PARAMETER		MIN	TYP	MAX	UNIT
$C_{XI}$	XI Capacitance			1.55	pF
$C_{XO}$	XO Capacitance			1.35	pF
$C_{XIXO}$	XI to XO Mutual Capacitance			0.9	fF
$t_s$	Maximum Start-up Time		9.5 <sup>(1)</sup>		ms

- (1) TI strongly encourages each customer to submit samples of the device to the resonator/crystal vendors for validation. The vendors are equipped to determine what load capacitors will best tune their resonator/crystal to the microcontroller device for optimum startup and operation over temperature/voltage extremes.



图 7-29. OSC1 Start-up Time

#### 7.10.4.1.3.1 Load Capacitance

The crystal circuit must be designed such that it applies the appropriate capacitive load to the crystal, as defined by the crystal manufacturer. The capacitive load,  $C_L$ , of this circuit is a combination of discrete capacitors  $C_{L1}$ ,  $C_{L2}$ , and several parasitic contributions. PCB signal traces which connect crystal circuit components to OSC1\_XI and OSC1\_XO have parasitic capacitance to ground,  $C_{PCBXI}$  and  $C_{PCBXO}$ , where the PCB designer should be able to extract parasitic capacitance for each signal trace. The OSC1 circuits and device package have combined parasitic capacitance to ground,  $C_{PCBXI}$  and  $C_{PCBXO}$ , where these parasitic capacitance values are defined in 表 7-24.

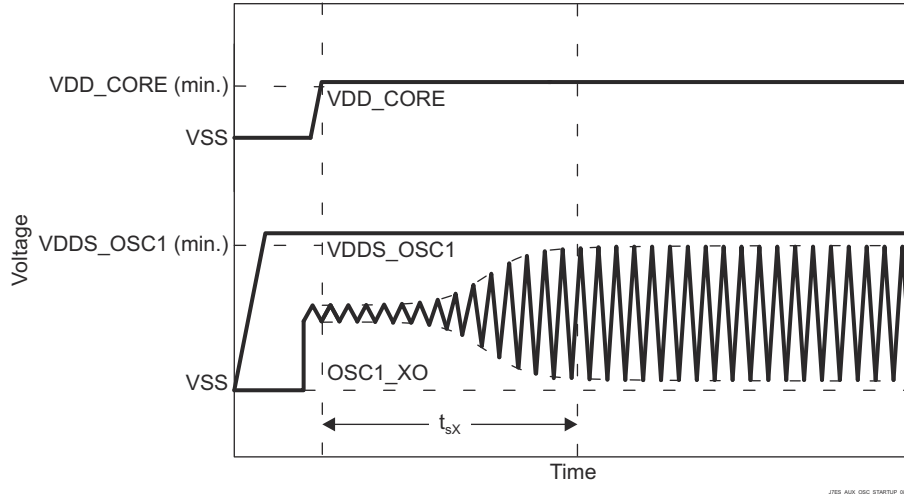

图 7-30. Load Capacitance

Load capacitors,  $C_{L1}$  and  $C_{L2}$  in 图 7-28, should be chosen such that the below equation is satisfied.  $C_L$  in the equation is the load specified by the crystal manufacturer.

$$C_L = [(C_{L1} + C_{PCBXI} + C_{X1}) \times (C_{L2} + C_{PCBXO} + C_{X0})] / [(C_{L1} + C_{PCBXI} + C_{X1}) + (C_{L2} + C_{PCBXO} + C_{X0})]$$

To determine the value of  $C_{L1}$  and  $C_{L2}$ , multiply the capacitive load value  $C_L$  by 2. Using this result, subtract the combined values of  $C_{PCBXI} + C_{X1}$  to determine the value of  $C_{L1}$  and the combined values of  $C_{PCBXO} + C_{X0}$  to determine the value of  $C_{L2}$ . For example, if  $C_L = 10$  pF,  $C_{PCBXI} = 2.9$  pF,  $C_{X1} = 0.5$  pF,  $C_{PCBXO} = 3.7$  pF,  $C_{X0} = 0.5$  pF, the value of  $C_{L1} = [(2C_L) - (C_{PCBXI} + C_{X1})] = [(2 \times 10 \text{ pF}) - 2.9 \text{ pF} - 0.5 \text{ pF}] = 16.6$  pF and  $C_{L2} = [(2C_L) - (C_{PCBXO} + C_{X0})] = [(2 \times 10 \text{ pF}) - 3.7 \text{ pF} - 0.5 \text{ pF}] = 15.8$  pF

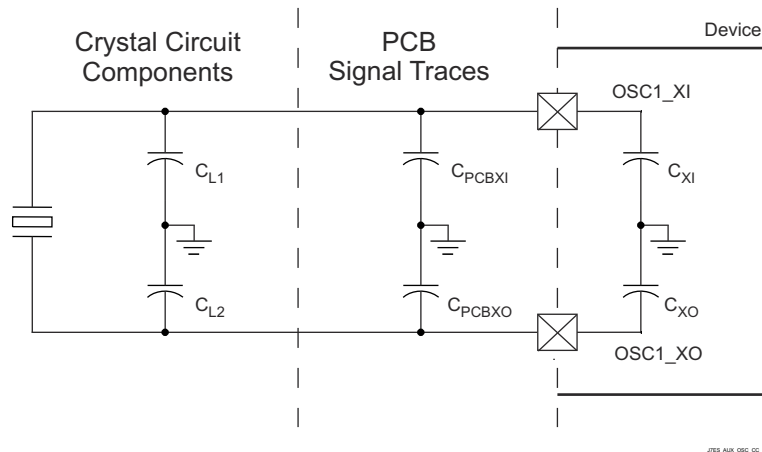
### 7.10.4.1.3.2 Shunt Capacitance

The crystal circuit must also be designed such that it does not exceed the maximum shunt capacitance for OSC1 operating conditions defined in 表 7-23. Shunt capacitance,  $C_{shunt}$ , of the crystal circuit is a combination of crystal shunt capacitance and parasitic contributions. PCB signal traces which connect crystal circuit components to OSC1 have mutual parasitic capacitance to each other,  $C_{PCBXIXO}$ , where the PCB designer should be able to extract mutual parasitic capacitance between these signal traces. The device package also has mutual parasitic capacitance,  $C_{XIXO}$ , where this mutual parasitic capacitance value is defined in 表 7-24.

PCB routing should be designed to minimize mutual capacitance between XI and XO signal traces. This is typically done by keeping signal traces short and not routing them in close proximity. Mutual capacitance can also be minimized by placing a ground trace between these signals when the layout requires them to be routed in close proximity. It is important to minimize the mutual capacitance on the PCB to provide as much margin as possible when selecting a crystal.



图 7-31. Shunt Capacitance

A crystal should be chosen such that the below equation is satisfied.  $C_O$  in the equation is the maximum shunt capacitance specified by the crystal manufacturer.

$$C_{shunt} \geq C_O + C_{PCBXIXO} + C_{XIXO}$$

For example, the equation would be satisfied when the crystal being used is 25 MHz with an ESR = 30  $\Omega$ ,  $C_{PCBXIXO} = 0.04$  pF,  $C_{XIXO} = 0.01$  pF, and shunt capacitance of the crystal is less than or equal to 6.95 pF.

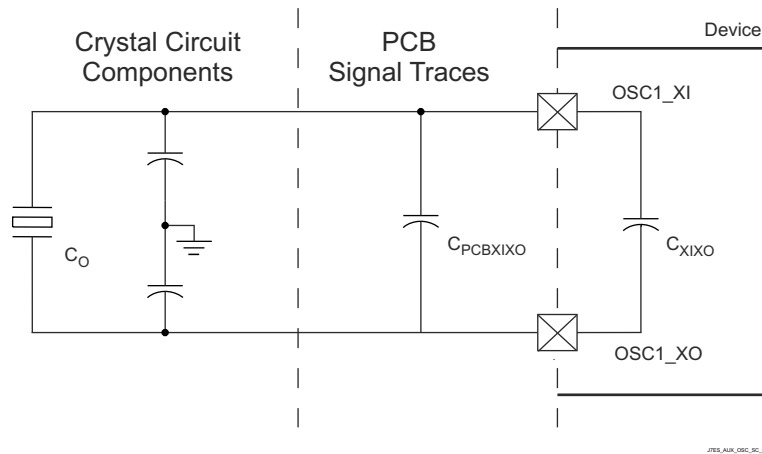
### 7.10.4.1.4 Auxiliary OSC1 LVCMOS Digital Clock Source

图 7-32 shows the recommended oscillator connections when OSC1 is connected to a 1.8-V LVCMOS square-wave digital clock source.

#### 备注

A DC steady-state condition is not allowed on OSC1\_XI when the oscillator is powered up. This is not allowed because OSC1\_XI is internally AC coupled to a comparator that may enter a unknown state when DC is applied to the input. Therefore, application software should power down OSC1 any time OSC1\_XI is not toggling between logic states.

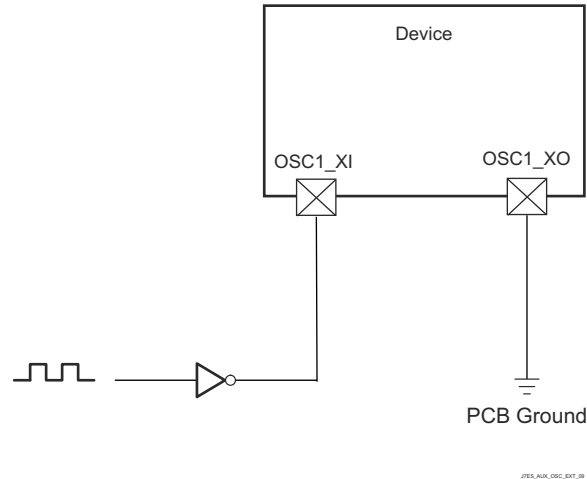

**图 7-32. 1.8-V LVCMOS-Compatible Clock Input**

#### 7.10.4.1.5 Auxiliary OSC1 Not Used

图 7-33 shows the recommended oscillator connections when OSC1 is not used. OSC1\_XI must be connected to VSS through an external pull resistor ( $R_{pd}$ ) to ensure this input is held to a valid low level when unused since the internal pull-down resistor is disabled by default.

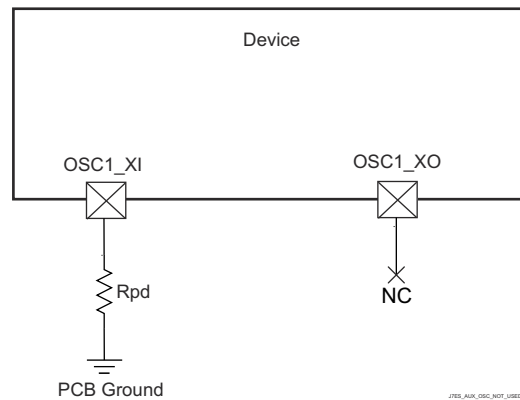

**图 7-33. OSC1 Not Used**

#### 7.10.4.2 Output Clocks

The device provides several system clock outputs. Summary of these output clocks are as follows:

- **MCU\_CLKOUT0**
  - Reference clock output for Ethernet PHYs (50 MHz or 25 MHz)
- **MCU\_SYSCLKOUT0**
  - MCU\_SYSCLK0 is divided by 4 and then sent out of the device as a LVCMOS clock signal (MCU\_SYSCLKOUT0). This signal can be used to test if the main chip clock is functioning or not. This signal should not be used as a clock source for external devices on a board.
- **MCU\_OBSCLK0**
  - On the clock output MCU\_OBSCLK0, oscillators and PLLs clocks can be observed for tests and debug. This signal should not be used as a clock source for external devices on a board.
- **SYCLKOUT0**
  - SYCLK0 is divided by 4 and then sent out of the device as a LVCMOS clock signal (SYCLKOUT0). This signal can be used to test if the main chip clock is functioning or not. This signal should not be used as a clock source for external devices on a board.

- **CLKOUT**
  - Reference clock output for Ethernet PHYs (50 MHz)
- **OBSCLK[1:0]**
  - On the clock output OBSCLK0/1, oscillators and PLLs clocks can be observed for tests and debug.

### 7.10.4.3 PLLs

Power is supplied to the Phase-Locked Loop circuitries (PLLs) by internal regulators that derive power from the off-chip power-supply.

There are total of three PLLs in the device in WKUP and MCU domains:

- MCU\_PLL0 (MCU R5FSS PLL) with WKUP\_PLLCTRL0
- MCU\_PLL1 (MCU PERIPHERAL PLL)
- MCU\_PLL2 (MCU CPSW PLL)

There are total of twenty PLLs in the device in MAIN domain:

- PLL0 (MAIN PLL) with PLLCTRL0
- PLL1 (PER0 PLL)
- PLL2 (PER1 PLL)
- PLL3 (CPSW9G PLL)
- PLL4 (AUDIO0 PLL)
- PLL5 (VIDEO PLL)
- PLL6 (GPU PLL)
- PLL7 (C7x PLL)
- PLL8 (ARM0 PLL)
- PLL12 (DDR PLL)
- PLL13 (C66 PLL)
- PLL14 (R5F PLL)
- PLL15 (AUDIO1 PLL)
- PLL16 (DSS PLL0)
- PLL17 (DSS PLL1)
- PLL18 (DSS PLL2)
- PLL19 (DSS PLL3)
- PLL23 (DSS PLL7)
- PLL24 (MLB PLL)
- PLL25 (VISION PLL)

---

#### 备注

For more information, see:

- *Device Configuration / Clocking / PLLs* section in the device TRM.
  - *Peripherals / Display Subsystem Overview* section in the device TRM.
- 

---

#### 备注

The input reference clock (OSC1\_XI/OSC1\_XO) is specified and the lock time is ensured by the PLL controller, as documented in the *Device Configuration* chapter in the device TRM.

---

### 7.10.4.4 Module and Peripheral Clocks Frequencies

节 7.10.5, *Peripherals* section documents the maximum frequency associated with the peripheral clocks of the device.

For more details on the clocking structure of each module, reference *Device Configurations* chapter in the device TRM.

## 7.10.5 Peripherals

### 7.10.5.1 ATL

The device contains ATL module that can be used for asynchronous sample rate conversion of audio. The ATL calculates the error between two time bases, such as audio syncs, and optionally generates an averaged clock using cycle stealing via software.

#### 备注

For more information about ATL, see *Audio Tracking Logic (ATL)* section in *Peripherals* chapter in the device TRM.

表 7-25 represents ATL timing conditions.

表 7-25. ATL Timing Conditions

PARAMETER		MODE	MIN	MAX	UNIT
<b>INPUT CONDITIONS</b>					
SR <sub>I</sub>	Input slew rate	External reference CLK	0.5	5	V/ns
<b>OUTPUT CONDITIONS</b>					
C <sub>L</sub>	Output load capacitance	Internal reference CLK	1	10	pF

节 7.10.5.1.1, 节 7.10.5.1.2, 节 7.10.5.1.3, and 节 7.10.5.1.4 present timing requirements and switching characteristics for ATL.

#### 7.10.5.1.1 ATL\_PCLK Timing Requirements

NO.	PARAMETER	MODE	MIN	MAX	UNIT
D1	t <sub>c(pclk)</sub>	Cycle time, ATL_PCLK		5	ns
D2	t <sub>w(pclkL)</sub>	Pulse Duration, ATL_PCLK low	External reference CLK	0.45 × M <sup>(1)</sup> + 2.5	ns
D3	t <sub>w(pclkH)</sub>	Pulse Duration, ATL_PCLK high	External reference CLK	0.45 × M <sup>(1)</sup> + 2.5	ns

(1) M = ATL\_CLK[x] period

#### 7.10.5.1.2 ATL\_AWS[x] Timing Requirements

NO.	PARAMETER	MODE	MIN	MAX	UNIT
D4	t <sub>c(aws)</sub>	Cycle Time, ATL_AWS[x] <sup>(3)</sup>	External reference CLK	2 × M <sup>(1)</sup>	ns
D5	t <sub>w(awsL)</sub>	Pulse Duration, ATL_AWS[x] <sup>(3)</sup> low	External reference CLK	0.45 × A <sup>(2)</sup> + 2.5	ns
D6	t <sub>w(awsH)</sub>	Pulse Duration, ATL_AWS[x] <sup>(3)</sup> high	External reference CLK	0.45 × A <sup>(2)</sup> + 2.5	ns

(1) M = ATL\_CLK[x] period

(2) A = ATL\_AWS[x] period

(3) x = 0 to 3

#### 7.10.5.1.3 ATL\_BWS[x] Timing Requirements

NO.	PARAMETER	MODE	MIN	MAX	UNIT
D7	t <sub>c(bws)</sub>	Cycle Time, ATL_BWS[x] <sup>(3)</sup>	External reference clock	2 × M <sup>(1)</sup>	ns
D8	t <sub>w(bwsL)</sub>	Pulse Duration, ATL_BWS[x] low <sup>(3)</sup>	External reference clock	0.45 × B <sup>(2)</sup> + 2.5	ns

NO.			MODE	MIN	MAX	UNIT
D9	$t_{w(bwsH)}$	Pulse Duration, ATCL_BWS[x] high <sup>(3)</sup>	External reference clock	$0.45 \times B^{(2)} + 2.5$		ns

- (1) M = ATCL\_CLK[x] period
- (2) B = ATCL\_BWS[x] period
- (3) x = 0 to 3

**7.10.5.1.4 ATCLK[x] Switching Characteristics**

NO.	PARAMETER		MODE	MIN	MAX	UNIT
D10	$t_{c(atclk)}$	Cycle time, ATCLK[x] <sup>(3)</sup>	Internal reference CLK	20		ns
D11	$t_{w(atclkL)}$	Pulse Duration, ATCLK[x] low <sup>(3)</sup>	Internal reference CLK	$0.45 \times P^{(2)} - M^{(1)} - 0.3$		ns
D12	$t_{w(atclkH)}$	Pulse Duration, ATCLK[x] high <sup>(3)</sup>	Internal reference CLK	$0.45 \times P^{(2)} - M^{(1)} - 0.3$		ns

- (1) M = ATCL\_CLK[x] period
- (2) P = ATCL\_CLK[x] period
- (3) x = 0 to 3

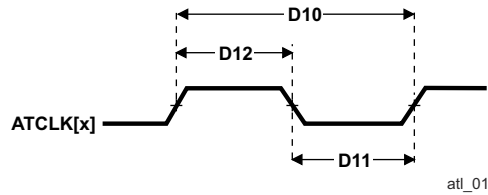

**图 7-34. ATCLK[x] Timing**

### 7.10.5.2 CPSW2G

For more details about features and additional description information on the device Gigabit Ethernet MAC, see the corresponding sections within [Signal Descriptions](#) and *Detailed Description*.

#### 7.10.5.2.1 CPSW2G MDIO Interface Timings

表 7-26 represents CPSW2G timing conditions.

表 7-26. CPSW2G MDIO Timing Conditions

PARAMETER	DESCRIPTION	MIN	MAX	UNIT
<b>INPUT CONDITIONS</b>				
SR <sub>I</sub>	Input signal slew rate	0.9	3.6	V/ns
<b>OUTPUT CONDITIONS</b>				
C <sub>L</sub>	Output load capacitance	10	470	pF

表 7-27, 表 7-28, and 图 7-35 present timing requirements for MDIO.

表 7-27. CPSW2G MDIO Timing Requirements

NO.		DESCRIPTION	MIN	MAX	UNIT
MDIO1	t <sub>su(mdioV-mdcH)</sub>	Setup time, MDIO[x]_MDIO valid before MDIO[x]_MDC high	90		ns
MDIO2	t <sub>h(mdcH-mdioV)</sub>	Hold time, MDIO[x]_MDIO valid after MDIO[x]_MDC high	0		ns

表 7-28. CPSW2G MDIO Switching Characteristics

NO.	PARAMETER	DESCRIPTION	MIN	MAX	UNIT
MDIO3	t <sub>c(mdc)</sub>	Cycle time, MDIO[x]_MDC	400		ns
MDIO4	t <sub>w(mdcH)</sub>	Pulse Duration, MDIO[x]_MDC high	160		ns
MDIO5	t <sub>w(mdcL)</sub>	Pulse Duration, MDIO[x]_MDC low	160		ns
MDIO7	t <sub>d(mdcL-mdioV)</sub>	Delay time, MDIO[x]_MDC low to MDIO[x]_MDIO valid	- 150	150	ns



图 7-35. CPSW2G MDIO Timing Requirements and Switching Characteristics

备注

x = 0 in MCU domain

### 7.10.5.2.2 CPSW2G RMII Timings

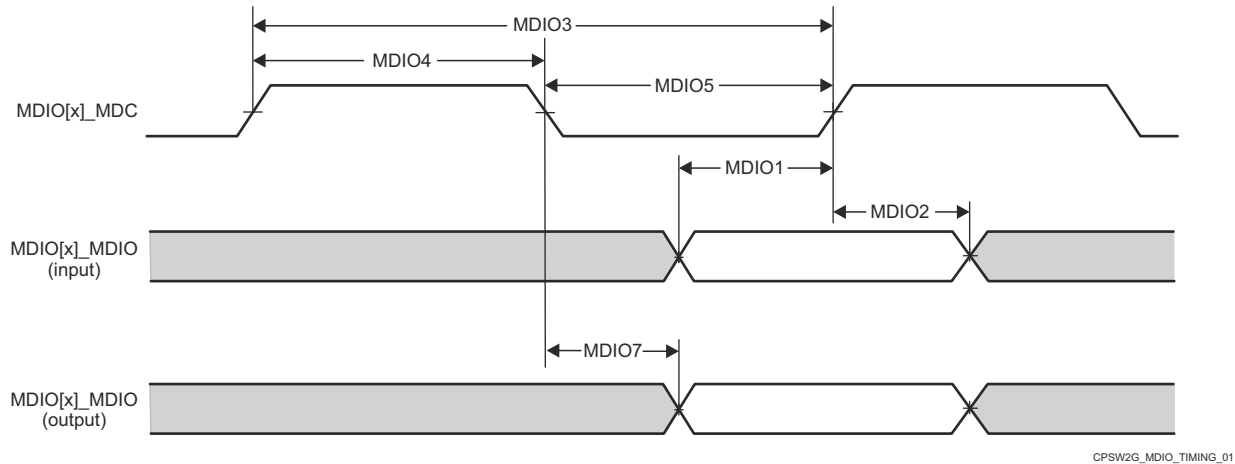
表 7-29, 节 7.10.5.2.2.1, 节 7.10.5.2.2.2, 和 节 7.10.5.2.2.3 present timing conditions, requirements, and switching characteristics for CPSW2G RMII.

表 7-29. CPSW2G RMII Timing Conditions

PARAMETER		MIN	MAX	UNIT	
<b>INPUT CONDITIONS</b>					
SR <sub>I</sub>	Input signal slew rate	VDD <sup>(1)</sup> = 1.8 V	0.108	0.54	V/ns
		VDD <sup>(1)</sup> = 3.3 V	0.4	1.2	V/ns
<b>OUTPUT CONDITIONS</b>					
C <sub>L</sub>	Output load capacitance	3	25	pF	

(1) VDD stands for corresponding power supply. For more information on the power supply name and the corresponding ball(s), see POWER column of the [Pin Attributes](#)

#### 7.10.5.2.2.1 CPSW2G RMII[x]\_REF\_CLK Timing Requirements - RMII Mode

see 图 7-36

NO.		MIN	MAX	UNIT
RMII1	t <sub>c(ref_clk)</sub>	Cycle time, RMII[x]_REF_CLK		19.999 20 ns
RMII2	t <sub>w(ref_clkH)</sub>	Pulse Duration, RMII[x]_REF_CLK high		7 13 ns
RMII3	t <sub>w(ref_clkL)</sub>	Pulse Duration, RMII[x]_REF_CLK low		7 13 ns

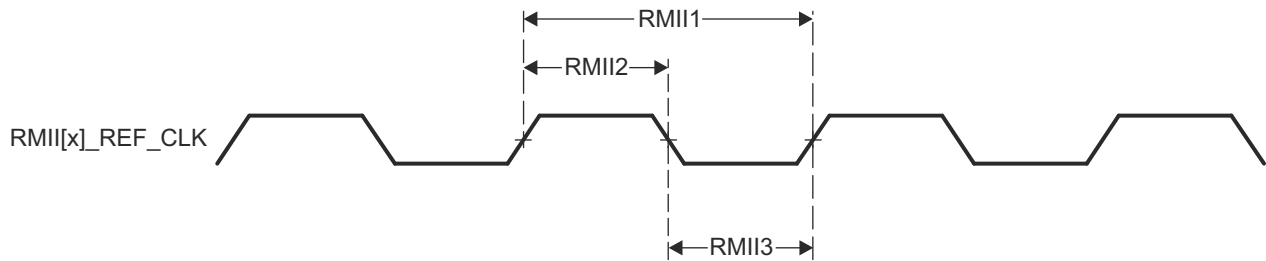

A. x = 1 in MCU domain.

图 7-36. CPSW2G RMII[x]\_REFCLK Timing Requirements - RMII Mode

#### 7.10.5.2.2.2 CPSW2G RMII[x]\_RXD[1:0], RMII[x]\_CRS\_DV, and RMII[x]\_RX\_ER Timing Requirements - RMII Mode

NO.		MIN	MAX	UNIT
RMII4	t <sub>su(rxdV-ref_clkH)</sub>	Setup time, RMII[x]_RXD[1:0] valid before RMII[x]_REF_CLK rising edge		4 ns
	t <sub>su(crs_dvV-ref_clkH)</sub>	Setup time, RMII[x]_CRS_DV valid before RMII[x]_REF_CLK rising edge		4 ns
	t <sub>su(rx_erV-ref_clkH)</sub>	Setup time, RMII[x]_RX_ER valid before RMII[x]_REF_CLK rising edge		4 ns
RMII5	t <sub>h(ref_clkH-rxdV)</sub>	Hold time, RMII[x]_RXD[1:0] valid after RMII[x]_REF_CLK rising edge		2 ns
	t <sub>h(ref_clkH-crs_dvV)</sub>	Hold time, RMII[x]_CRS_DV valid after RMII[x]_REF_CLK rising edge		2 ns
	t <sub>h(ref_clkH-rx_erV)</sub>	Hold time, RMII[x]_RX_ER valid after RMII[x]_REF_CLK rising edge		2 ns



图 7-37. CPSW2G RMII[x]\_RXD[1:0], RMII[x]\_CRS\_DV, RMII[x]\_RX\_ER Timing Requirements - RMII Mode

节 7.10.5.2.2.3, and 图 7-38 present switching characteristics for CPSW2G RMII Transmit.

7.10.5.2.2.3 CPSW2G RMII[x]\_TXD[1:0], and RMII[x]\_TX\_EN Switching Characteristics - RMII Mode

see 图 7-38

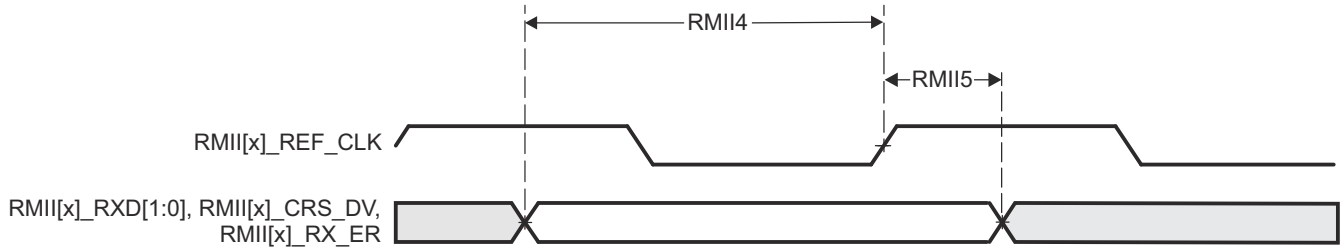
NO.	PARAMETER		MIN	MAX	UNIT
RMIIX6	$t_{d(\text{ref\_clkH-txdV})}$	Delay time, RMII[x]_REF_CLK rising edge to RMII[x]_TXD[1:0] valid	2	10	ns
	$t_{d(\text{ref\_clkH-tx\_enV})}$	Delay time, RMII[x]_REF_CLK rising edge to RMII[x]_TX_EN valid	2	10	ns



图 7-38. RMII[x]\_TXD[1:0], and RMII[x]\_TX\_EN Switching Characteristics - RMII Mode

7.10.5.2.3 CPSW2G RGMII Timings

节 7.10.5.2.3.1, 节 7.10.5.2.3.2, and 图 7-40 present timing requirements for receive RGMII operation.

For more information, see *Gigabit Ethernet MAC (MCU\_CPSW0)* section in *Peripherals* chapter in the device TRM.

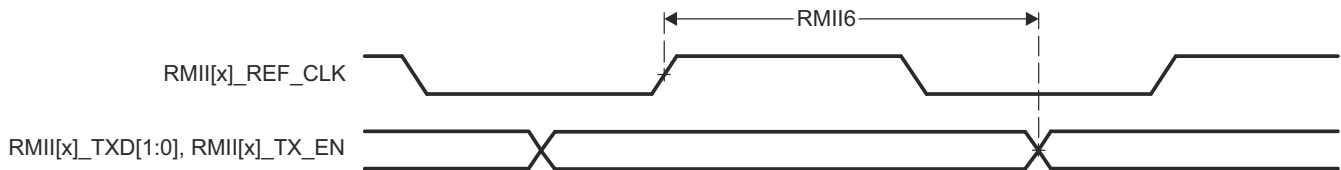
表 7-30. CPSW2G RGMII Timing Conditions

PARAMETER			MIN	MAX	UNIT
<b>INPUT CONDITIONS</b>					
SR <sub>i</sub>	Input slew rate	VDD <sup>(1)</sup> = 1.8 V	1.44	5	V/ns
		VDD <sup>(1)</sup> = 3.3 V	2.64	5	V/ns
<b>OUTPUT CONDITIONS</b>					
C <sub>L</sub>	Output load capacitance		2	20	pF
<b>PCB CONNECTIVITY REQUIREMENTS</b>					
t <sub>d</sub> (Trace Mismatch Delay)	Propagation delay mismatch across all traces	RGMII[x]_RXC, RGMII[x]_RD[3:0], RGMII[x]_RX_CTL		50	ps
		RGMII[x]_TXC, RGMII[x]_TD[3:0], RGMII[x]_TX_CTL		50	ps

(1) VDD stands for corresponding power supply. For more information on the power supply name and the corresponding ball(s), see POWER column of the Pin Attributes.

### 7.10.5.2.3.1 RGMII[x]\_RXC Timing Requirements - RGMII Mode

see 图 7-39

NO.			MODE	MIN	MAX	UNIT
RGMII1	$t_{c(rx)}$	Cycle time, RGMII[x]_RXC	10Mbps	360	440	ns
			100Mbps	36	44	ns
			1000Mbps	7.2	8.8	ns
RGMII2	$t_{w(rxch)}$	Pulse duration, RGMII[x]_RXC high	10Mbps	160	240	ns
			100Mbps	16	24	ns
			1000Mbps	3.6	4.4	ns
RGMII3	$t_{w(rxcl)}$	Pulse duration, RGMII[x]_RXC low	10Mbps	160	240	ns
			100Mbps	16	24	ns
			1000Mbps	3.6	4.4	ns

### 7.10.5.2.3.2 CPSW2G Timing Requirements for RGMII[x]\_RD[3:0], and RGMII[x]\_RCTL - RGMII Mode

see 图 7-39

NO.			MODE	MIN	MAX	UNIT
RGMII4	$t_{su(rdV-rxcV)}$	Setup time, RGMII[x]_RD[3:0] valid before RGMII[x]_RXC transition	10Mbps	1		ns
			100Mbps	1		ns
			1000Mbps	1		ns
RGMII4	$t_{su(rx_ctlV-rxcV)}$	Setup time, RGMII[x]_RX_CTL valid before RGMII[x]_RXC transition	10Mbps	1		ns
			100Mbps	1		ns
			1000Mbps	1		ns
RGMII5	$t_{h(rxV-rdV)}$	Hold time, RGMII[x]_RD[3:0] valid after RGMII[x]_RXC transition	10Mbps	1		ns
			100Mbps	1		ns
			1000Mbps	1		ns
RGMII5	$t_{h(rxV-rx_ctlV)}$	Hold time, RGMII[x]_RX_CTL valid after RGMII[x]_RXC transition	10Mbps	1		ns
			100Mbps	1		ns
			1000Mbps	1		ns

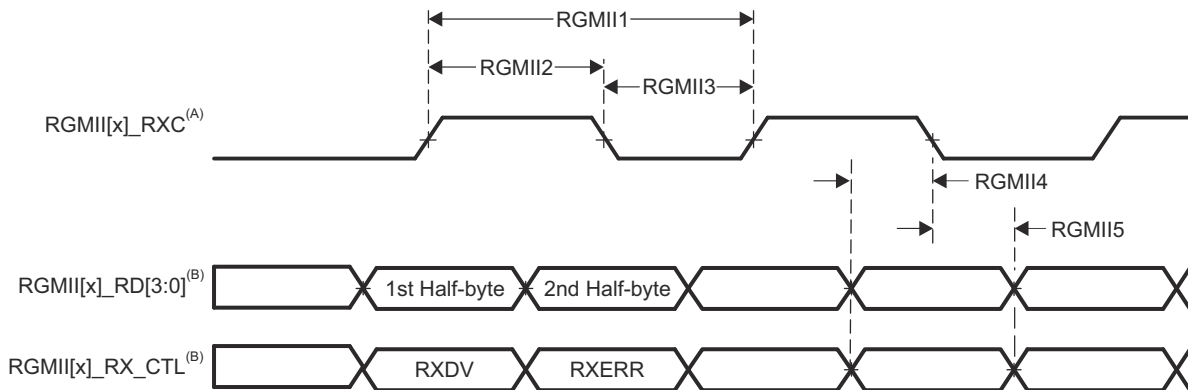

- A. RGMII\_RXC must be externally delayed relative to the data and control pins.
- B. Data and control information is received using both edges of the clocks. RGMII\_RXD[3:0] carries data bits 3-0 on the rising edge of RGMII\_RXC and data bits 7-4 on the falling edge of RGMII\_RXC. Similarly, RGMII\_RXCTL carries RXDV on rising edge of RGMII\_RXC and RXERR on falling edge of RGMII\_RXC.

图 7-39. CPSW2G Receive Interface Timing, RGMII Operation

节 7.10.5.2.3.3, 节 7.10.5.2.3.4 present switching characteristics for transmit - RGMII for 10 Mbps, 100 Mbps, and 1000 Mbps.

7.10.5.2.3.3 CPSW2G RGMII[x]\_TXC Switching Characteristics - RGMII Mode

NO.	PARAMETER		MODE	MIN	MAX	UNIT
RGMII6	$t_{c(tc)}$	Cycle time, RGMII[x]_TXC	10Mbps	360	440	ns
			100Mbps	36	44	ns
			1000Mbps	7.2	8.8	ns
RGMII7	$t_{w(tcH)}$	Pulse duration, RGMII[x]_TXC high	10Mbps	160	240	ns
			100Mbps	16	24	ns
			1000Mbps	3.6	4.4	ns
RGMII8	$t_{w(tcL)}$	Pulse duration, RGMII[x]_TXC low	10Mbps	160	240	ns
			100Mbps	16	24	ns
			1000Mbps	3.6	4.4	ns

7.10.5.2.3.4 RGMII[x]\_TD[3:0], and RGMII[x]\_TX\_CTL Switching Characteristics - RGMII Mode

see 图 7-40

NO.	PARAMETER		MODE	MIN	MAX	UNIT
RGMII9	$t_{osu(tdV-txcV)}$	Output setup time, RGMII[x]_TD[3:0] valid to RGMII[x]_TXC transition	10Mbps	1.2		ns
			100Mbps	1.2		ns
			1000Mbps	1.2		ns
	$t_{osu(tx_ctlV-txcV)}$	Output setup time, RGMII[x]_TX_CTL valid to RGMII[x]_TXC transition	10Mbps	1.2		ns
			100Mbps	1.2		ns
			1000Mbps	1.2		ns
RGMII10	$t_{oh(tdV-txcV)}$	Output hold time, RGMII[x]_TD[3:0] valid after RGMII[x]_TXC transition	10Mbps	1.2		ns
			100Mbps	1.2		ns
			1000Mbps	1.2		ns
	$t_{oh(tx_ctlV-txcV)}$	Output hold time, RGMII[x]_TX_CTL valid after RGMII[x]_TXC transition	10Mbps	1.2		ns
			100Mbps	1.2		ns
			1000Mbps	1.2		ns

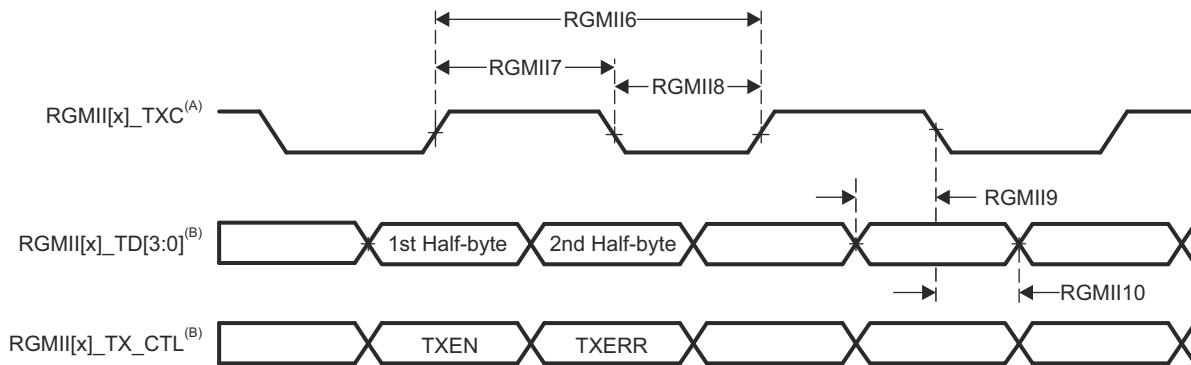

- A. TXC is delayed internally before being driven to the RGMII[x]\_TXC pin. This internal delay is always enabled.
- B. Data and control information is received using both edges of the clocks. RGMII\_TD[3:0] carries data bits 3-0 on the rising edge of RGMII\_TXC and data bits 7-4 on the falling edge of RGMII\_TXC. Similarly, RGMII\_TX\_CTL carries TXDV on rising edge of RGMII\_TXC and RTXERR on falling edge of RGMII\_TXC.

图 7-40. CPSW2G Transmit Interface Timing RGMII Mode

### 7.10.5.3 CSI-2

#### 备注

For more information, see the Camera Streaming Interface Receiver (CSI\_RX\_IF) chapter in the device TRM.

The CSI\_RX\_IF deals with the processing of the pixel data coming from an external image sensor and data from memory. It is a key component for the following multimedia applications: camera viewfinder, video record, and still image capture.

The CSI\_RX\_IF has a primary serial interface (CSI-2 port) compliant with the MIPI D-PHY RX specification v1.2 and the MIPI CSI-2 specification v1.3, with 4 differential data lanes plus 1 differential clock lane in synchronous mode, double data rate. Refer to the specification for timing details.

- 2.5 Gbps (1.25 GHz) for each lane.

### 7.10.5.4 DDRSS

For more details about features and additional description information on the device LPDDR4 Memory Interfaces, see the corresponding sections within [Signal Descriptions](#) and *Detailed Description*.

The device has dedicated interface to LPDDR4. It supports JEDEC JESD209-4B standard compliant LPDDR4 SDRAM devices with the following features:

- 32-bit data path to external SDRAM memory
- Memory device capacity: Up to 8GB address space available over two chip selects (4GB per rank)
- No support for byte mode LPDDR4 memories, or memories with more than 17 row address bits

表 7-31 和 图 7-41 呈现 switching characteristics for DDRSS.

表 7-31. Switching Characteristics for DDRSS

NO.	PARAMETER	DDR TYPE	MIN	MAX	UNIT
1	$t_{c(DDR\_CKP/DDR\_CKN)}$ Cycle time, DDR0_CKP and DDR0_CKN	LPDDR4	0.4681	3.003	ns

1. Maximum DDR Frequency will be limited based on the specific memory type (vendor) used in a system and by PCB implementation. TI strongly recommends all designs to follow the TI LPDDR4 EVM PCB layout exactly in every detail (routing, spacing, vias/backdrill, PCB material, etc.) in order to achieve the full specified clock frequency. Refer to the Jacinto 7 DDR Board Design and Layout Guidelines for details.



图 7-41. DDRSS Memory Interface Clock Timing

For more information, see *DDR Subsystem (DDRSS)* section in *Memory Controllers* chapter in the device TRM.

### 7.10.5.5 DSS

For more details about features and additional description information on the device Display Subsystem - Video Output Ports, see the corresponding sections within [Signal Descriptions](#) and *Detailed Description*.

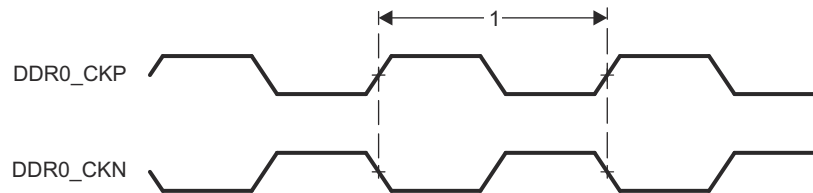
表 7-32 代表 DPI timing conditions.

表 7-32. DPI Timing Conditions

PARAMETER	MIN	MAX	UNIT
INPUT CONDITIONS			

表 7-32. DPI Timing Conditions (continued)

PARAMETER		MIN	MAX	UNIT
SR <sub>I</sub>	Input slew rate	1.44	26.4	V/ns
<b>OUTPUT CONDITIONS</b>				
C <sub>L</sub>	Output load capacitance	1.5	5	pF
<b>PCB CONNECTIVITY REQUIREMENTS</b>				
t <sub>d</sub> (Trace Mismatch Delay)	Propagation delay mismatch across all traces		100	ps

表 7-33, 表 7-34, 图 7-42 和 图 7-43 assume testing over the recommended operating conditions and electrical characteristic conditions.

表 7-33. DPI Video Output Switching Characteristics

NO.(2)	PARAMETER		MIN	MAX	UNIT
D1	t <sub>c</sub> (pclk)	Cycle time, VOUT(x)_PCLK	6.06		ns
D2	t <sub>w</sub> (pclkL)	Pulse duration, VOUT(x)_PCLK low	0.475×P(1)		ns
D3	t <sub>w</sub> (pclkH)	Pulse duration, VOUT(x)_PCLK high	0.475×P(1)		ns
D4	t <sub>d</sub> (pclkV-dataV)	Delay time, VOUT(x)_PCLK transition to VOUT(x)_DATA[23:0] transition	-0.68	1.78	ns
D5	t <sub>d</sub> (pclkV-ctrlL)	Delay time, VOUT(x)_PCLK transition to control signals VOUT(x)_VSYNC, VOUT(x)_HSYNC, VOUT(x)_DE falling edge	-0.68	1.78	ns

(1) P = output VOUT(x)\_PCLK period in ns.

(2) x in VOUT(x) = 1 or 2

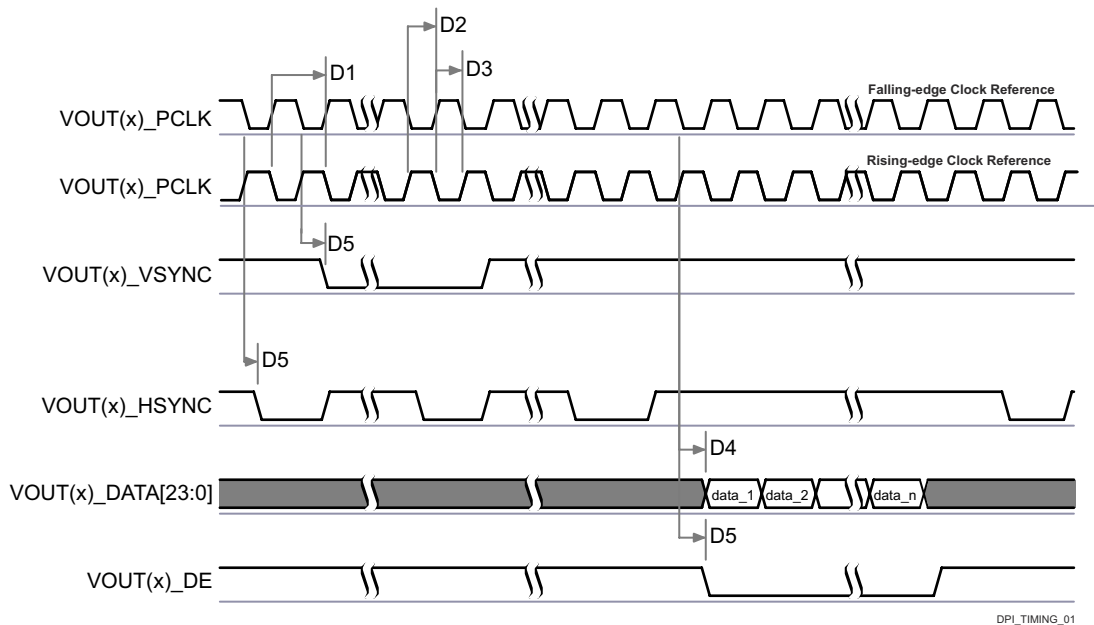

- A. The configuration of assertion of the data can be programmed on the falling or rising edge of the pixel clock.
- B. The polarity and the pulse width of VOUT(x)\_HSYNC and VOUT(x)\_VSYNC are programmable, refer to *Display Subsystem (DSS)* section in *Peripherals* chapter in the device TRM.
- C. The VOUT(x)\_PCLK frequency can be configured, refer to *Display Subsystem* section in *Peripherals* chapter in the device TRM.
- D. x in VOUT(x) = 1 or 2.

图 7-42. DPI Video Output

表 7-34. DPI External Pixel Clock Timing Requirements

NO. (2)			MIN	MAX	UNIT
D6	$t_{c(\text{extpclk})}$	Cycle time, VOUT(x)_EXTPCLKIN	6.06		ns
D7	$t_{w(\text{extpclkL})}$	Pulse duration, VOUT(x)_EXTPCLKIN low	$0.45 \times P^{(1)}$		ns
D8	$t_{w(\text{extpclkH})}$	Pulse duration, VOUT(x)_EXTPCLKIN high	$0.45 \times P^{(1)}$		ns

- (1) P = output VOUT(x)\_PCLK period in ns.  
(2) x in VOUT(x) = 1 or 2



图 7-43. DPI External Pixel Clock Input

For more information, see *Display Subsystem (DSS) and Peripherals* section in *Peripherals* chapter in the device TRM.

### 7.10.5.6 eCAP

The supported features by the device ECAP are:

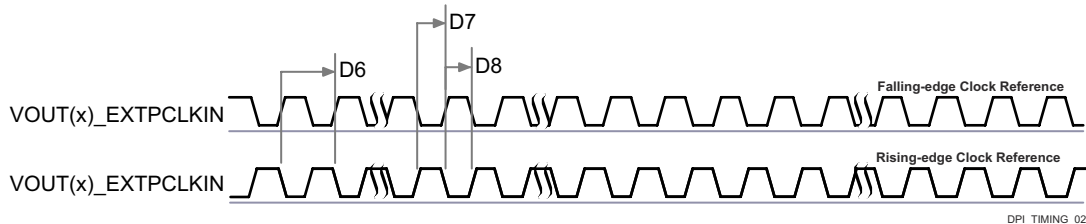
- 32-bit time base counter
- 4-event time-stamp registers (each 32 bits)
- Independent edge polarity selection for up to four sequenced time-stamp capture events
- Interrupt capabilities on any of the four capture events
- Input capture signal pre-scaling (from 1 to 16)
- Support of different capture modes (single shot capture, continuous mode capture, absolute timestamp capture or difference mode time-stamp capture)

表 7-35 represents ECAP timing conditions.

表 7-35. ECAP Timing Conditions

PARAMETER		MIN	MAX	UNIT
<b>INPUT CONDITIONS</b>				
SR <sub>I</sub>	Input slew rate	1	4	V/ns
<b>OUTPUT CONDITIONS</b>				
C <sub>L</sub>	Output load capacitance	2	7	pF

节 7.10.5.6.1 和 节 7.10.5.6.2 present timing and switching characteristics for eCAP (see 图 7-44 和 图 7-45).

### 7.10.5.6.1 Timing Requirements for eCAP

NO.	PARAMETER	DESCRIPTION	MIN	MAX	UNIT
CAP1	$t_{w(\text{cap})}$	Pulse duration, CAP (asynchronous)	$2 + 2P^{(1)}$		ns

(1)  $P = \text{sysclk}$



图 7-44. eCAP Input Timings

### 7.10.5.6.2 Switching Characteristics for eCAP

NO.	PARAMETER	DESCRIPTION	MIN	MAX	UNIT
CAP2	$t_{w(\text{apwm})}$	Pulse duration, APWM	$- 2 + 2P^{(1)}$		ns

(1)  $P = \text{sysclk}$

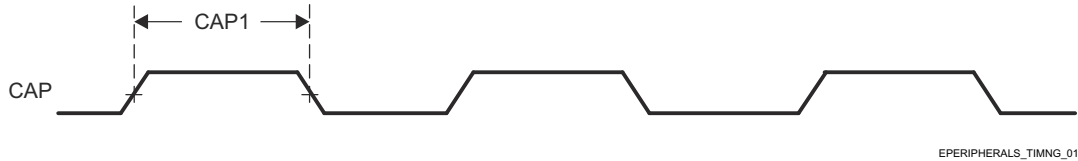

图 7-45. eCAP Output Timings

For more information, see *Enhanced Capture (ECAP) Module* section in *Peripherals* chapter in the device TRM.

### 7.10.5.7 EPWM

The supported features by the device EPWM are:

- Dedicated 16-bit time-base counter with period and frequency control
- Two independent PWM outputs which can be used in different configurations (with single-edge operation, with dual-edge symmetric operation or one independent PWM output with dual-edge asymmetric operation)
- Asynchronous override control of PWM signals during fault conditions
- Programmable phase-control support for lag or lead operation relative to other EPWM modules
- Dead-band generation with independent rising and falling edge delay control
- Programmable trip zone allocation of both latched and un-latched fault conditions
- Events enabling to trigger both CPU interrupts and start of ADC conversions

表 7-36 represents EPWM timing conditions.

表 7-36. EPWM Timing Conditions

PARAMETER	DESCRIPTION	MIN	MAX	UNIT
<b>INPUT CONDITIONS</b>				
$SR_i$	Input slew rate	1	4	V/ns
<b>OUTPUT CONDITIONS</b>				
$C_L$	Output load capacitance	2	7	pF

节 7.10.5.7.2, 节 7.10.5.7.1 and present timing and switching characteristics for eHRPWM (see 图 7-47, 图 7-48, 图 7-49, and 图 7-46).

### 7.10.5.7.1 Timing Requirements for eHRPWM

NO.	PARAMETER	DESCRIPTION	MIN	MAX	UNIT
PWM6	$t_{w(\text{synci})}$	Pulse duration, EHRPWM_SYNCI	$2 + 2P^{(1)}$		ns
PWM7	$t_{w(\text{tz})}$	Pulse duration, EHRPWM_TZn_IN low	$2 + 3P^{(1)}$		ns

(1) P = sysclk



图 7-46. ePWM\_SYNCI and ePWM\_TZn\_IN Output Timings

For more information, see *Camera Subsystem* section in *Peripherals* chapter in the device TRM.

### 7.10.5.7.2 Switching Characteristics for eHRPWM

NO.	PARAMETER	DESCRIPTION	MIN	MAX	UNIT
PWM1	$t_{w(\text{pwm})}$	Pulse duration, EHRPWM_A/B, high or low	P-3 <sup>(1)</sup>		ns
PWM2	$t_{w(\text{syncout})}$	Pulse duration, EHRPWM_SYNCO	P-3 <sup>(1)</sup>		ns
PWM3	$t_{d(\text{tzL-pwmV})}$	Delay time, EHRPWM_TZn_IN falling edge to EHRPWM_A/B valid		11	ns
PWM4	$t_{d(\text{tzL-pwmZ})}$	Delay time, EHRPWM_TZn_IN falling edge to EHRPWM_A/B Hi-Z		11	ns

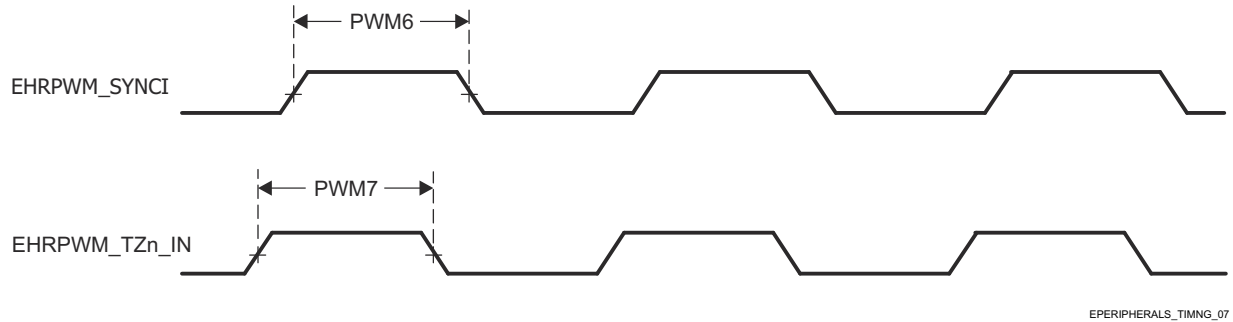
NO.	PARAMETER	DESCRIPTION	MIN	MAX	UNIT
PWM5	$t_{w(soc)}$	Pulse duration, EHRPWM_SOC A/B	P-3 <sup>(1)</sup>		ns

(1) P = sysclk



图 7-47. EPWM\_A/B\_out, ePWM\_SYNCO, and ePWM\_SOC A/B Input Timings



图 7-48. EPWM\_A/B and ePWM\_TZn\_IN Forced High/Low Input Timings

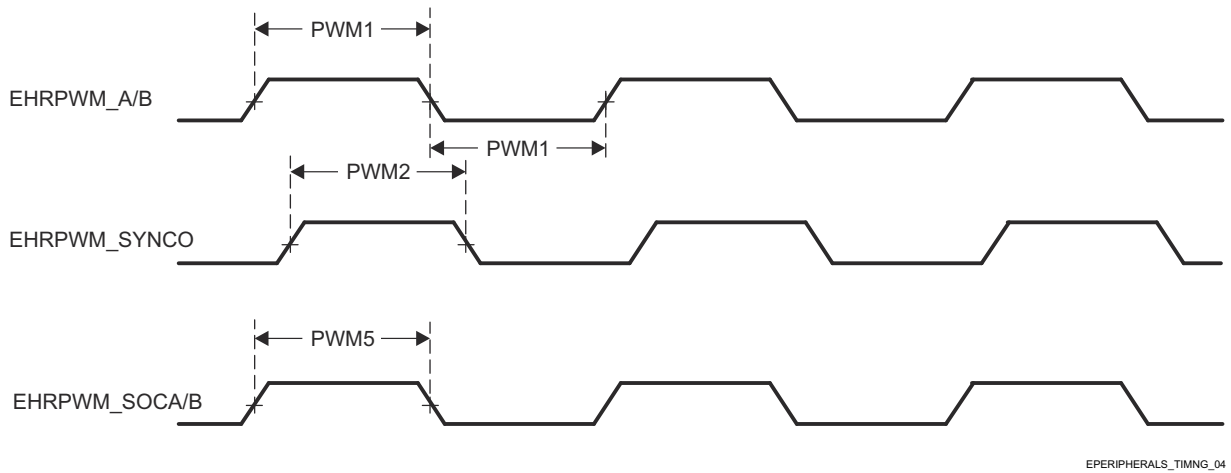

图 7-49. EPWM\_A/B and ePWM\_TZn\_IN Hi - Z Input Timings

### 7.10.5.8 eQEP

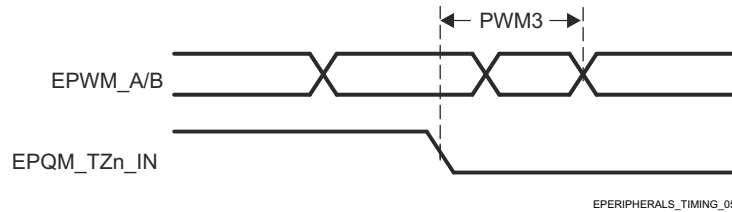
The supported features by the device eQEP are:

- Input Synchronization
- Three Stage/Six Stage Digital Noise Filter
- Quadrature Decoder Unit
- Position Counter and Control unit for position measurement
- Quadrature Edge Capture unit for low speed measurement
- Unit Time base for speed/frequency measurement
- Watchdog Timer for detecting stalls

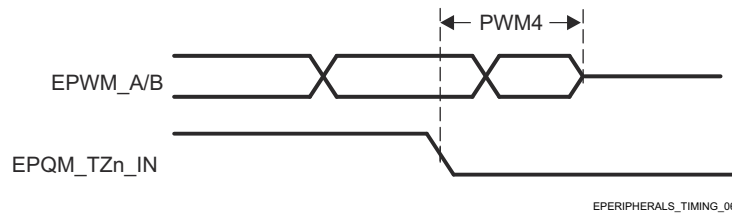
表 7-37 represents EQEP timing conditions.

表 7-37. EQEP Timing Conditions

PARAMETER		MIN	MAX	UNIT
<b>INPUT CONDITIONS</b>				
SR <sub>I</sub>	Input slew rate	1	4	V/ns
<b>OUTPUT CONDITIONS</b>				
C <sub>L</sub>	Output load capacitance	2	7	pF

节 7.10.5.8.1 和 节 7.10.5.8.2 present timing requirements and switching characteristics for eQEP (see 图 7-50).

### 7.10.5.8.1 Timing Requirements for eQEP

NO.	PARAMETER	MIN	MAX	UNIT
QEP1	t <sub>w(QEP)</sub>	2 + 2P <sup>(1)</sup>		ns
QEP2	t <sub>w(QEPiH)</sub>	2 + 2P <sup>(1)</sup>		ns
QEP3	t <sub>w(QEPiL)</sub>	2 + 2P <sup>(1)</sup>		ns
QEP4	t <sub>w(QEPsH)</sub>	2 + 2P <sup>(1)</sup>		ns
QEP5	t <sub>w(QEPsL)</sub>	2 + 2P <sup>(1)</sup>		ns

(1) P = sysclk



图 7-50. eQEP Input Timings

### 7.10.5.8.2 Switching Characteristics for eQEP

NO.	PARAMETER	MIN	MAX	UNIT
QEP6	t <sub>d(QEP-CNTR)</sub>	Delay time, external clock to counter increment		24 ns

For more information, see *Enhanced Quadrature Encoder Pulse (EQEP) Module* section in *Peripherals* chapter in the device TRM.

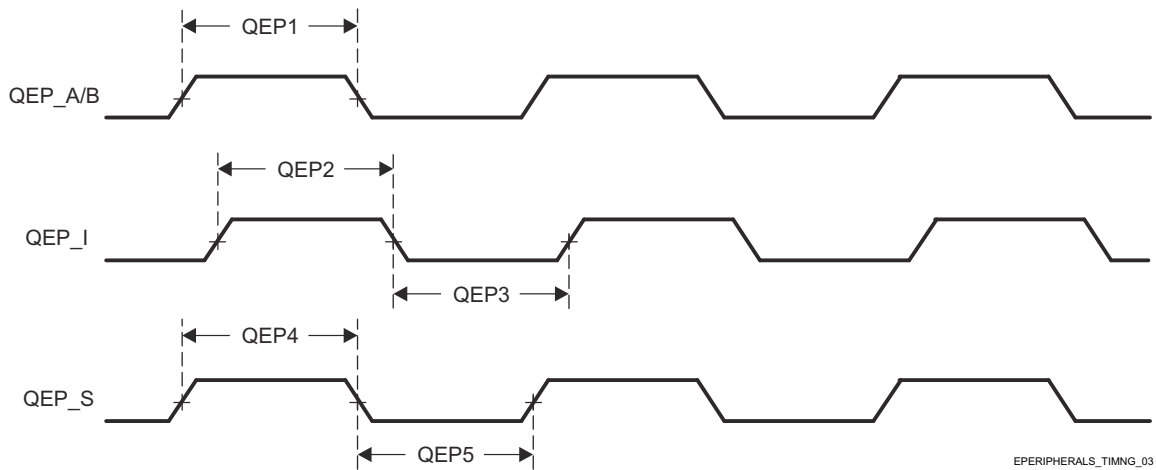
### 7.10.5.9 GPIO

The device has ten instances of GPIO modules. The GPIO modules are integrated in three groups.

- Group one: WKUP\_GPIO0 and WKUP\_GPIO1
- Group two: GPIO0, GPIO2, GPIO4, and GPIO6
- Group three: GPIO1, GPIO3, GPIO5, and GPIO7

Within each group, exactly one module is selected to control the corresponding I/O pins and pin interrupts.

The GPIO pins are grouped into banks (16 pins per bank), which means that each GPIO module provides up to 144 dedicated general-purpose pins with input and output capabilities; thus, the general-purpose interface supports up to 432 (3 instances × (9 banks × 16 pins)) pins. Since WKUP\_GPIOu\_[84:143] (u = 0, 1), GPIO<sub>n</sub>\_[128:143] (n = 0, 2, 4, 6), and GPIO<sub>m</sub>\_[36:143] (m = 1, 3, 5, 7) are reserved in this device, general purpose interface supports up to 248 I/O pins.

For more details about features and additional description information on the device General-Purpose Interface, see the corresponding sections within [Signal Descriptions](#) and *Detailed Description*.

---

备注

The general-purpose input/output *i* (*i* = 0 to 1) is also referred to as GPIO<sub>*i*</sub>.

---

表 7-38, 节 7.10.5.9.1, 和 节 7.10.5.9.2 present timing conditions, requirements, and switching characteristics for GPIO.

**表 7-38. GPIO Timing Conditions**

PARAMETER		BUFFER TYPE	MIN	MAX	UNIT
<b>INPUT CONDITIONS</b>					
SR <sub><i>i</i></sub>	Input slew rate	LVC MOS	0.2	6.6	V/ns
		I2C OD FS	0.2	0.8	V/ns
<b>OUTPUT CONDITIONS</b>					
C <sub>L</sub>	Output load capacitance	LVC MOS	3	10	pF
		I2C OD FS	3	100	pF

#### 7.10.5.9.1 GPIO Timing Requirements

NO.	PARAMETER		BUFFER TYPE	MIN	MAX	UNIT
GPIO1	t <sub>w(gpio_in)</sub>	Pulse width, GPIO <sub>n</sub> _x	1.8 V	2P + 2.6 <sup>(1)</sup>		ns
			3.3 V	2P + 3.4 <sup>(1)</sup>		ns

(1) P = functional clock period in ns.

#### 7.10.5.9.2 GPIO Switching Characteristics

NO.	PARAMETER		BUFFER TYPE	MIN	MAX	UNIT
GPIO3	t <sub>w(GPIO_OUT)</sub>	Minimum Output Pulse Width	LVC MOS	- 3.6 + 0.975P <sup>(1)</sup>		ns
GPIO4	t <sub>w(GPIO_OUT)</sub>	Minimum Output Pulse Width Low	I2C Open Drain	160		ns
GPIO5	t <sub>w(GPIO_OUT)</sub>	Minimum Output Pulse Width High	I2C Open Drain	60		ns

(1) P = functional clock period in ns.

For more information, see *General-Purpose Interface (GPIO)* section in *Peripherals* chapter in the device TRM.

#### 7.10.5.10 GPMC

For more details about features and additional description information on the device General-Purpose Memory Controller, see the corresponding sections within [Signal Descriptions](#) and *Detailed Description*.

表 7-39 represents GPMC timing conditions.

---

备注

The IO timings provided in this section are applicable for all combinations of signals for GPMC0. However, the timings are only valid for GPMC0 if signals within a single IOSET are used. The IOSETs are defined in the [GPMC0\\_IOSET](#), *GPMC0\_IOSET* table.

---

表 7-39. GPMC Timing Conditions

PARAMETER	DESCRIPTION	MIN	MAX	UNIT	
<b>Input Conditions</b>					
SR <sub>i</sub>	Input slew rate	1.65	4	V/ns	
<b>Output Conditions</b>					
C <sub>L</sub>	Output load capacitance	5	20	pF	
<b>PCB Connectivity Requirements</b>					
t <sub>d</sub> (Trace Delay)	Propagation delay of each trace	133 MHz Synchronous Mode	140	360	ps
		All other modes	140	720	
t <sub>d</sub> (Trace Mismatch Delay)	Propagation mismatch across all traces		200	ps	

### 7.10.5.10.1 GPMC and NOR Flash — Synchronous Mode

节 7.10.5.10.1.1 和 节 7.10.5.10.1.2 assume testing over the recommended operating conditions and electrical characteristic conditions below (see 图 7-51 through 图 7-55).

#### 7.10.5.10.1.1 GPMC and NOR Flash Timing Requirements — Synchronous Mode

NO.	PARAMETER	DESCRIPTION <sup>(2)</sup>	MODE <sup>(3)</sup>	MIN	MAX	MIN	MAX	UNIT
				100 MHz <sup>(4)</sup>		133 MHz <sup>(4)</sup>		
F12	t <sub>su</sub> (dV-clkH)	Setup time, input data GPMC_AD[15:0] valid before output clock GPMC_CLK high	div_by_1_mode; GPMC_FCLK_MUX; TIMEPARAGRANULARITY_X1	1.81		1.11		ns
			not_div_by_1_mode; GPMC_FCLK_MUX; TIMEPARAGRANULARITY_X1	1.06				ns
F13	t <sub>h</sub> (clkH-dV)	Hold time, input data GPMC_AD[15:0] valid after output clock GPMC_CLK high	div_by_1_mode; GPMC_FCLK_MUX; TIMEPARAGRANULARITY_X1	1.78		2.28		ns
			not_div_by_1_mode; GPMC_FCLK_MUX; TIMEPARAGRANULARITY_X1	1.78				ns
F21	t <sub>su</sub> (waitV-clkH)	Setup time, input wait GPMC_WAIT[j] valid before output clock GPMC_CLK high <sup>(1)</sup>	div_by_1_mode; GPMC_FCLK_MUX; TIMEPARAGRANULARITY_X1	1.81		1.11		ns
			not_div_by_1_mode; GPMC_FCLK_MUX; TIMEPARAGRANULARITY_X1	1.06				ns
F22	t <sub>h</sub> (clkH-waitV)	Hold time, input wait GPMC_WAIT[j] valid after output clock GPMC_CLK high <sup>(1)</sup>	div_by_1_mode; GPMC_FCLK_MUX; TIMEPARAGRANULARITY_X1	1.78		2.28		ns
			not_div_by_1_mode; GPMC_FCLK_MUX; TIMEPARAGRANULARITY_X1	1.78				ns

(1) In GPMC\_WAIT[j], j is equal to 0, 1, 2, or 3.

(2) Wait monitoring support is limited to a WaitMonitoringTime value > 0. For a full description of wait monitoring feature, see *General-Purpose Memory Controller (GPMC)* section in the device TRM.

(3) For div\_by\_1\_mode:

- GPMC\_CONFIG1\_i Register: GPMCFCLKDIVIDER = 0h:
  - GPMC\_CLK frequency = GPMC\_FCLK frequency
- GPMC\_CONFIG1\_i Register: GPMCFCLKDIVIDER = 1h to 3h:
  - GPMC\_CLK frequency = GPMC\_FCLK frequency / (2 to 4)
- CTRLMMR\_GPMC\_CLKSEL[1-0] CLK\_SEL = 01 = PER1\_PLL\_CLKOUT / 3 = 300 / 3 = 100 MHz

- For TIMEPARAGRANULARITY\_X1:
  - GPMC\_CONFIG1\_i Register: TIMEPARAGRANULARITY = 0h = x1 latencies (affecting RD/WRCYCLETIME, RD/WRACCESTIME, PAGEBURSTACCESTIME, CSNTIME, CSRD/WROFFTIME, ADVONTIME, ADVRD/WROFFTIME, OEONTIME, OEOFFTIME, WEONTIME, WEOFFTIME, CYCLE2CYCLEDELAY, BUSTURNAROUND, TIMEOUTSTARTVALUE, WRDATAONADMUXBUS)

(4) For 100 MHz:

- CTRLMMR\_GPMC\_CLKSEL[1-0] CLK\_SEL = 01 = MAIN\_PLL2\_HSDIV1\_CLKOUT / 3

For 133 MHz:

- CTRLMMR\_GPMC\_CLKSEL[1-0] CLK\_SEL = 00 = MAIN\_PLL0\_HSDIV3\_CLKOUT

**7.10.5.10.1.2 GPMC and NOR Flash Switching Characteristics - Synchronous Mode**

NO.(2)	PARAMETER	DESCRIPTION	MODE(19)	MIN	MAX	MIN	MAX	UNIT
				100 MHz(20)		133 MHz(20)		
F0	tc(clk)	Period, output clock GPMC_CLK(18)	div_by_1_mode; ; GPMC_FCLK_MUX; TIMEPARAGRANULARITY_X1	10		7.52		ns
F1	t <sub>w</sub> (clkH)	Typical pulse duration, output clock GPMC_CLK high	div_by_1_mode ; GPMC_FCLK_MUX; TIMEPARAGRANULARITY_X1	0.475*P (15)- 0.3		0.475*P (15)- 0.3		ns
F1	t <sub>w</sub> (clkL)	Typical pulse duration, output clock GPMC_CLK low	div_by_1_mode ; GPMC_FCLK_MUX; TIMEPARAGRANULARITY_X1	0.475*P (15)- 0.3		0.475*P (15)- 0.3		ns
F2	t <sub>d</sub> (clkH-csnV)	Delay time, output clock GPMC_CLK rising edge to output chip select GPMC_CSn[i] transition(14)	div_by_1_mode ; GPMC_FCLK_MUX; TIMEPARAGRANULARITY_X1 no extra_delay	F(6)- 2.2	F+3.75	F(6)- 2.2	F(6)+ 3.75	ns
F3	t <sub>d</sub> (clkH-CSn[i]V)	Delay time, output clock GPMC_CLK rising edge to output chip select GPMC_CSn[i] invalid(14)	div_by_1_mode ; GPMC_FCLK_MUX; TIMEPARAGRANULARITY_X1 no extra_delay	E(5)- 2.2	E(5)+ 3.75	E(5)- 2.2	E(5)+ 3.75	ns
F4	t <sub>d</sub> (aV-clk)	Delay time, output address GPMC_A[27:1] valid to output clock GPMC_CLK first edge	div_by_1_mode ; GPMC_FCLK_MUX; TIMEPARAGRANULARITY_X1	B(2)-2.3	B(2)+4.5	B(2)-2.3	B(2)+4.5	ns
F5	t <sub>d</sub> (clkH-aV)	Delay time, output clock GPMC_CLK rising edge to output address GPMC_A[27:1] invalid	div_by_1_mode; GPMC_FCLK_MUX; TIMEPARAGRANULARITY_X1	- 2.3	4.5	- 2.3	4.5	ns
F6	t <sub>d</sub> (be[x]nV-clk)	Delay time, output lower byte enable and command latch enable GPMC_BE0n_CLE, output upper byte enable GPMC_BE1n valid to output clock GPMC_CLK first edge	div_by_1_mode ; GPMC_FCLK_MUX; TIMEPARAGRANULARITY_X1	B(2)-2.3	B(2)+1.9	B(2)-2.3	B(2)+1.9	ns
F7	t <sub>d</sub> (clkH-be[x]nV)	Delay time, output clock GPMC_CLK rising edge to output lower byte enable and command latch enable GPMC_BE0n_CLE, output upper byte enable GPMC_BE1n invalid(11)	div_by_1_mode ; GPMC_FCLK_MUX; TIMEPARAGRANULARITY_X1	D(4)-2.3	D(4)+1.9	D(4)-2.3	D(4)+1.9	ns
F7	t <sub>d</sub> (clkL-be[x]nV)	Delay time, GPMC_CLK falling edge to GPMC_BE0n_CLE, GPMC_BE1n invalid(12)	div_by_1_mode ; GPMC_FCLK_MUX; TIMEPARAGRANULARITY_X1	D(4)-2.3	D(4)+1.9	D(4)-2.3	D(4)+1.9	ns

NO. <sup>(2)</sup>	PARAMETER	DESCRIPTION	MODE <sup>(19)</sup>	MIN	MAX	MIN	MAX	UNI T
				100 MHz <sup>(20)</sup>		133 MHz <sup>(20)</sup>		
F7	$t_{d(\text{clkL-be}[x]nV)}$	Delay time, GPMC_CLK falling edge to GPMC_BE0n_CLE, GPMC_BE1n invalid <sup>(13)</sup>	div_by_1_mode ; GPMC_FCLK_MUX; TIMEPARAGRANULARITY_X1	D <sup>(4)</sup> -2.3	D <sup>(4)</sup> +1.9	D <sup>(4)</sup> -2.3	D <sup>(4)</sup> +1.9	ns
F8	$t_{d(\text{clkH-advn})}$	Delay time, output clock GPMC_CLK rising edge to output address valid and address latch enable GPMC_ADVn_ALE transition	div_by_1_mode ; GPMC_FCLK_MUX; TIMEPARAGRANULARITY_X1 no extra_delay	G <sup>(7)</sup> -2.3	G <sup>(7)</sup> +4.5	G <sup>(7)</sup> -2.3	G <sup>(7)</sup> +4.5	ns
F9	$t_{d(\text{clkH-advnIV})}$	Delay time, output clock GPMC_CLK rising edge to output address valid and address latch enable GPMC_ADVn_ALE invalid	div_by_1_mode; GPMC_FCLK_MUX; TIMEPARAGRANULARITY_X1 no extra_delay	D <sup>(4)</sup> -2.3	D <sup>(4)</sup> +4.5	D <sup>(4)</sup> -2.3	D <sup>(4)</sup> +4.5	ns
F10	$t_{d(\text{clkH-oen})}$	Delay time, output clock GPMC_CLK rising edge to output enable GPMC_OEn_REn transition	div_by_1_mode ; GPMC_FCLK_MUX; TIMEPARAGRANULARITY_X1 no extra_delay	H <sup>(8)</sup> -2.3	H <sup>(8)</sup> +3.5	H <sup>(8)</sup> -2.3	H <sup>(8)</sup> +3.5	ns
F11	$t_{d(\text{clkH-oenIV})}$	Delay time, output clock GPMC_CLK rising edge to output enable GPMC_OEn_REn invalid	div_by_1_mode ; GPMC_FCLK_MUX; TIMEPARAGRANULARITY_X1 no extra_delay	E <sup>(8)</sup> -2.3	E <sup>(8)</sup> +3.5	E <sup>(8)</sup> -2.3	E <sup>(8)</sup> +3.5	ns
F14	$t_{d(\text{clkH-wen})}$	Delay time, output clock GPMC_CLK rising edge to output write enable GPMC_WEn transition	div_by_1_mode ; GPMC_FCLK_MUX; TIMEPARAGRANULARITY_X1 no extra_delay	I <sup>(9)</sup> -2.3	I <sup>(9)</sup> +4.5	I <sup>(9)</sup> -2.3	I <sup>(9)</sup> +4.5	ns
F15	$t_{d(\text{clkH-do})}$	Delay time, output clock GPMC_CLK rising edge to output data GPMC_AD[15:0] transition <sup>(11)</sup>	div_by_1_mode ; GPMC_FCLK_MUX; TIMEPARAGRANULARITY_X1	J <sup>(10)</sup> -2.3	J <sup>(10)</sup> +2.7	J <sup>(10)</sup> -2.3	J <sup>(10)</sup> +2.7	ns
F15	$t_{d(\text{clkL-do})}$	Delay time, GPMC_CLK falling edge to GPMC_AD[15:0] data bus transition <sup>(12)</sup>	div_by_1_mode ; GPMC_FCLK_MUX; TIMEPARAGRANULARITY_X1	J <sup>(10)</sup> -2.3	J <sup>(10)</sup> +2.7	J <sup>(10)</sup> -2.3	J <sup>(10)</sup> +2.7	ns
F15	$t_{d(\text{clkL-do})}$	Delay time, GPMC_CLK falling edge to GPMC_AD[15:0] data bus transition <sup>(13)</sup>	div_by_1_mode ; GPMC_FCLK_MUX; TIMEPARAGRANULARITY_X1	J <sup>(10)</sup> -2.3	J <sup>(10)</sup> +2.7	J <sup>(10)</sup> -2.3	J <sup>(10)</sup> +2.7	ns
F17	$t_{d(\text{clkH-be}[x]n)}$	Delay time, output clock GPMC_CLK rising edge to output lower byte enable and command latch enable GPMC_BE0n_CLE transition <sup>(11)</sup>	div_by_1_mode ; GPMC_FCLK_MUX; TIMEPARAGRANULARITY_X1	J <sup>(10)</sup> -2.3	J <sup>(10)</sup> +1.9	J <sup>(10)</sup> -2.3	J <sup>(10)</sup> +1.9	ns
F17	$t_{d(\text{clkL-be}[x]n)}$	Delay time, GPMC_CLK falling edge to GPMC_BE0n_CLE, GPMC_BE1n transition <sup>(12)</sup>	div_by_1_mode ; GPMC_FCLK_MUX; TIMEPARAGRANULARITY_X1	J <sup>(10)</sup> -2.3	J <sup>(10)</sup> +1.9	J <sup>(10)</sup> -2.3	J <sup>(10)</sup> +1.9	ns
F17	$t_{d(\text{clkL-be}[x]n)}$	Delay time, GPMC_CLK falling edge to GPMC_BE0n_CLE, GPMC_BE1n transition <sup>(13)</sup>	div_by_1_mode ; GPMC_FCLK_MUX; TIMEPARAGRANULARITY_X1	J <sup>(10)</sup> -2.3	J <sup>(10)</sup> +1.9	J <sup>(10)</sup> -2.3	J <sup>(10)</sup> +1.9	ns
F18	$t_{w(\text{csnV})}$	Pulse duration, output chip select GPMC_CSn[i] low <sup>(14)</sup>	Read	A <sup>(1)</sup>		A <sup>(1)</sup>		ns
			Write	A <sup>(1)</sup>		A <sup>(1)</sup>		ns
F19	$t_{w(\text{be}[x]nV)}$	Pulse duration, output lower byte enable and command latch enable GPMC_BE0n_CLE, output upper byte enable GPMC_BE1n low	Read	C <sup>(3)</sup>		C <sup>(3)</sup>		ns
			Write	C <sup>(3)</sup>		C <sup>(3)</sup>		ns

NO. <sup>(2)</sup>	PARAMETER	DESCRIPTION	MODE <sup>(19)</sup>	MIN	MAX	MIN	MAX	UNIT
				100 MHz <sup>(20)</sup>		133 MHz <sup>(20)</sup>		
F20	t <sub>w(advnV)</sub>	Pulse duration, output address valid and address latch enable GPMC_ADVn_ALE low	Read	K <sup>(16)</sup>		K <sup>(16)</sup>		ns
			Write	K <sup>(16)</sup>		K <sup>(16)</sup>		ns

- (1) For single read:  $A = (\text{CSRdOffTime} - \text{CSOnTime}) \times (\text{TimeParaGranularity} + 1) \times \text{GPMC\_FCLK}^{(17)}$   
 For burst read:  $A = (\text{CSRdOffTime} - \text{CSOnTime} + (n - 1) \times \text{PageBurstAccessTime}) \times (\text{TimeParaGranularity} + 1) \times \text{GPMC\_FCLK}^{(17)}$   
 For burst write:  $A = (\text{CSWrOffTime} - \text{CSOnTime} + (n - 1) \times \text{PageBurstAccessTime}) \times (\text{TimeParaGranularity} + 1) \times \text{GPMC\_FCLK}^{(17)}$   
 With n being the page burst access number.

(2)  $B = \text{ClkActivationTime} \times \text{GPMC\_FCLK}^{(17)}$

- (3) For single read:  $C = \text{RdCycleTime} \times (\text{TimeParaGranularity} + 1) \times \text{GPMC\_FCLK}^{(17)}$   
 For burst read:  $C = (\text{RdCycleTime} + (n - 1) \times \text{PageBurstAccessTime}) \times (\text{TimeParaGranularity} + 1) \times \text{GPMC\_FCLK}^{(17)}$   
 For burst write:  $C = (\text{WrCycleTime} + (n - 1) \times \text{PageBurstAccessTime}) \times (\text{TimeParaGranularity} + 1) \times \text{GPMC\_FCLK}^{(17)}$   
 With n being the page burst access number.

(4) For single read:  $D = (\text{RdCycleTime} - \text{AccessTime}) \times (\text{TimeParaGranularity} + 1) \times \text{GPMC\_FCLK}^{(17)}$   
 For burst read:  $D = (\text{RdCycleTime} - \text{AccessTime}) \times (\text{TimeParaGranularity} + 1) \times \text{GPMC\_FCLK}^{(17)}$

For burst write:  $D = (\text{WrCycleTime} - \text{AccessTime}) \times (\text{TimeParaGranularity} + 1) \times \text{GPMC\_FCLK}^{(17)}$

(5) For single read:  $E = (\text{CSRdOffTime} - \text{AccessTime}) \times (\text{TimeParaGranularity} + 1) \times \text{GPMC\_FCLK}^{(17)}$   
 For burst read:  $E = (\text{CSRdOffTime} - \text{AccessTime}) \times (\text{TimeParaGranularity} + 1) \times \text{GPMC\_FCLK}^{(17)}$   
 For burst write:  $E = (\text{CSWrOffTime} - \text{AccessTime}) \times (\text{TimeParaGranularity} + 1) \times \text{GPMC\_FCLK}^{(17)}$

- (6) For csn falling edge (CS activated):

- Case GPMCFCLKDIVIDER = 0:
  - $F = 0.5 \times \text{CSExtraDelay} \times \text{GPMC\_FCLK}^{(17)}$
- Case GPMCFCLKDIVIDER = 1:
  - $F = 0.5 \times \text{CSExtraDelay} \times \text{GPMC\_FCLK}^{(17)}$  if (ClkActivationTime and CSOnTime are odd) or (ClkActivationTime and CSOnTime are even)
  - $F = (1 + 0.5 \times \text{CSExtraDelay}) \times \text{GPMC\_FCLK}^{(17)}$  otherwise
- Case GPMCFCLKDIVIDER = 2:
  - $F = 0.5 \times \text{CSExtraDelay} \times \text{GPMC\_FCLK}^{(17)}$  if ((CSOnTime - ClkActivationTime) is a multiple of 3)
  - $F = (1 + 0.5 \times \text{CSExtraDelay}) \times \text{GPMC\_FCLK}^{(17)}$  if ((CSOnTime - ClkActivationTime - 1) is a multiple of 3)
  - $F = (2 + 0.5 \times \text{CSExtraDelay}) \times \text{GPMC\_FCLK}^{(17)}$  if ((CSOnTime - ClkActivationTime - 2) is a multiple of 3)

- (7) For ADV falling edge (ADV activated):

- Case GPMCFCLKDIVIDER = 0:
  - $G = 0.5 \times \text{ADVExtraDelay} \times \text{GPMC\_FCLK}^{(17)}$
- Case GPMCFCLKDIVIDER = 1:
  - $G = 0.5 \times \text{ADVExtraDelay} \times \text{GPMC\_FCLK}^{(17)}$  if (ClkActivationTime and ADVOnTime are odd) or (ClkActivationTime and ADVOnTime are even)
  - $G = (1 + 0.5 \times \text{ADVExtraDelay}) \times \text{GPMC\_FCLK}^{(17)}$  otherwise
- Case GPMCFCLKDIVIDER = 2:
  - $G = 0.5 \times \text{ADVExtraDelay} \times \text{GPMC\_FCLK}^{(17)}$  if ((ADVOnTime - ClkActivationTime) is a multiple of 3)
  - $G = (1 + 0.5 \times \text{ADVExtraDelay}) \times \text{GPMC\_FCLK}^{(17)}$  if ((ADVOnTime - ClkActivationTime - 1) is a multiple of 3)
  - $G = (2 + 0.5 \times \text{ADVExtraDelay}) \times \text{GPMC\_FCLK}^{(17)}$  if ((ADVOnTime - ClkActivationTime - 2) is a multiple of 3)

For ADV rising edge (ADV deactivated) in Reading mode:

- Case GPMCFCLKDIVIDER = 0:
  - $G = 0.5 \times \text{ADVExtraDelay} \times \text{GPMC\_FCLK}^{(17)}$
- Case GPMCFCLKDIVIDER = 1:
  - $G = 0.5 \times \text{ADVExtraDelay} \times \text{GPMC\_FCLK}^{(17)}$  if (ClkActivationTime and ADVrOffTime are odd) or (ClkActivationTime and ADVrOffTime are even)
  - $G = (1 + 0.5 \times \text{ADVExtraDelay}) \times \text{GPMC\_FCLK}^{(17)}$  otherwise
- Case GPMCFCLKDIVIDER = 2:
  - $G = 0.5 \times \text{ADVExtraDelay} \times \text{GPMC\_FCLK}^{(17)}$  if ((ADVrOffTime - ClkActivationTime) is a multiple of 3)
  - $G = (1 + 0.5 \times \text{ADVExtraDelay}) \times \text{GPMC\_FCLK}^{(17)}$  if ((ADVrOffTime - ClkActivationTime - 1) is a multiple of 3)
  - $G = (2 + 0.5 \times \text{ADVExtraDelay}) \times \text{GPMC\_FCLK}^{(17)}$  if ((ADVrOffTime - ClkActivationTime - 2) is a multiple of 3)

For ADV rising edge (ADV deactivated) in Writing mode:

- Case GPMCFCLKDIVIDER = 0:
  - $G = 0.5 \times \text{ADVExtraDelay} \times \text{GPMC\_FCLK}^{(17)}$
- Case GPMCFCLKDIVIDER = 1:
  - $G = 0.5 \times \text{ADVExtraDelay} \times \text{GPMC\_FCLK}^{(17)}$  if (ClkActivationTime and ADVWrOffTime are odd) or (ClkActivationTime and ADVWrOffTime are even)
  - $G = (1 + 0.5 \times \text{ADVExtraDelay}) \times \text{GPMC\_FCLK}^{(17)}$  otherwise
- Case GPMCFCLKDIVIDER = 2:
  - $G = 0.5 \times \text{ADVExtraDelay} \times \text{GPMC\_FCLK}^{(17)}$  if ((ADVWrOffTime - ClkActivationTime) is a multiple of 3)
  - $G = (1 + 0.5 \times \text{ADVExtraDelay}) \times \text{GPMC\_FCLK}^{(17)}$  if ((ADVWrOffTime - ClkActivationTime - 1) is a multiple of 3)
  - $G = (2 + 0.5 \times \text{ADVExtraDelay}) \times \text{GPMC\_FCLK}^{(17)}$  if ((ADVWrOffTime - ClkActivationTime - 2) is a multiple of 3)

(8) For OE falling edge (OE activated) and IO DIR rising edge (Data Bus input direction):

- Case GPMCFCLKDIVIDER = 0:
  - $H = 0.5 \times \text{OEXtraDelay} \times \text{GPMC\_FCLK}^{(17)}$
- Case GPMCFCLKDIVIDER = 1:
  - $H = 0.5 \times \text{OEXtraDelay} \times \text{GPMC\_FCLK}^{(17)}$  if (ClkActivationTime and OEOnTime are odd) or (ClkActivationTime and OEOnTime are even)
  - $H = (1 + 0.5 \times \text{OEXtraDelay}) \times \text{GPMC\_FCLK}^{(17)}$  otherwise
- Case GPMCFCLKDIVIDER = 2:
  - $H = 0.5 \times \text{OEXtraDelay} \times \text{GPMC\_FCLK}^{(17)}$  if ((OEOnTime - ClkActivationTime) is a multiple of 3)
  - $H = (1 + 0.5 \times \text{OEXtraDelay}) \times \text{GPMC\_FCLK}^{(17)}$  if ((OEOnTime - ClkActivationTime - 1) is a multiple of 3)
  - $H = (2 + 0.5 \times \text{OEXtraDelay}) \times \text{GPMC\_FCLK}^{(17)}$  if ((OEOnTime - ClkActivationTime - 2) is a multiple of 3)

For OE rising edge (OE deactivated):

- Case GPMCFCLKDIVIDER = 0:
  - $H = 0.5 \times \text{OEXtraDelay} \times \text{GPMC\_FCLK}^{(17)}$
- Case GPMCFCLKDIVIDER = 1:
  - $H = 0.5 \times \text{OEXtraDelay} \times \text{GPMC\_FCLK}^{(17)}$  if (ClkActivationTime and OEOffTime are odd) or (ClkActivationTime and OEOffTime are even)
  - $H = (1 + 0.5 \times \text{OEXtraDelay}) \times \text{GPMC\_FCLK}^{(17)}$  otherwise
- Case GPMCFCLKDIVIDER = 2:
  - $H = 0.5 \times \text{OEXtraDelay} \times \text{GPMC\_FCLK}^{(17)}$  if ((OEOffTime - ClkActivationTime) is a multiple of 3)
  - $H = (1 + 0.5 \times \text{OEXtraDelay}) \times \text{GPMC\_FCLK}^{(17)}$  if ((OEOffTime - ClkActivationTime - 1) is a multiple of 3)
  - $H = (2 + 0.5 \times \text{OEXtraDelay}) \times \text{GPMC\_FCLK}^{(17)}$  if ((OEOffTime - ClkActivationTime - 2) is a multiple of 3)

(9) For WE falling edge (WE activated):

- Case GPMCFCLKDIVIDER = 0:
  - $I = 0.5 \times \text{WEExtraDelay} \times \text{GPMC\_FCLK}^{(17)}$
- Case GPMCFCLKDIVIDER = 1:
  - $I = 0.5 \times \text{WEExtraDelay} \times \text{GPMC\_FCLK}^{(17)}$  if (ClkActivationTime and WEOnTime are odd) or (ClkActivationTime and WEOnTime are even)
  - $I = (1 + 0.5 \times \text{WEExtraDelay}) \times \text{GPMC\_FCLK}^{(17)}$  otherwise
- Case GPMCFCLKDIVIDER = 2:
  - $I = 0.5 \times \text{WEExtraDelay} \times \text{GPMC\_FCLK}^{(17)}$  if ((WEOnTime - ClkActivationTime) is a multiple of 3)
  - $I = (1 + 0.5 \times \text{WEExtraDelay}) \times \text{GPMC\_FCLK}^{(17)}$  if ((WEOnTime - ClkActivationTime - 1) is a multiple of 3)
  - $I = (2 + 0.5 \times \text{WEExtraDelay}) \times \text{GPMC\_FCLK}^{(17)}$  if ((WEOnTime - ClkActivationTime - 2) is a multiple of 3)

For WE rising edge (WE deactivated):

- Case GPMCFCLKDIVIDER = 0:
  - $I = 0.5 \times \text{WEExtraDelay} \times \text{GPMC\_FCLK}^{(17)}$
- Case GPMCFCLKDIVIDER = 1:
  - $I = 0.5 \times \text{WEExtraDelay} \times \text{GPMC\_FCLK}^{(17)}$  if (ClkActivationTime and WEOffTime are odd) or (ClkActivationTime and WEOffTime are even)

- $I = (1 + 0.5 \times \text{WEEExtraDelay}) \times \text{GPMC\_FCLK}^{(17)}$  otherwise
  - Case GPMCFCLKDIVIDER = 2:
    - $I = 0.5 \times \text{WEEExtraDelay} \times \text{GPMC\_FCLK}^{(17)}$  if  $((\text{WEOffTime} - \text{ClkActivationTime})$  is a multiple of 3)
    - $I = (1 + 0.5 \times \text{WEEExtraDelay}) \times \text{GPMC\_FCLK}^{(17)}$  if  $((\text{WEOffTime} - \text{ClkActivationTime} - 1)$  is a multiple of 3)
    - $I = (2 + 0.5 \times \text{WEEExtraDelay}) \times \text{GPMC\_FCLK}^{(17)}$  if  $((\text{WEOffTime} - \text{ClkActivationTime} - 2)$  is a multiple of 3)
  - (10)  $J = \text{GPMC\_FCLK}^{(17)}$
  - (11) First transfer only for CLK DIV 1 mode.
  - (12) Half cycle; for all data after initial transfer for CLK DIV 1 mode.
  - (13) Half cycle of GPMC\_CLKOUT; for all data for modes other than CLK DIV 1 mode. GPMC\_CLKOUT divide down from GPMC\_FCLK.
  - (14) In GPMC\_CS*n*[*i*], *i* is equal to 0, 1, 2, or 3. In GPMC\_WAIT[*j*], *j* is equal to 0, 1, 2, or 3.
  - (15)  $P = \text{GPMC\_CLK}$  period in ns
  - (16) For read:  $K = (\text{ADVrdOffTime} - \text{ADVOnTime}) \times (\text{TimeParaGranularity} + 1) \times \text{GPMC\_FCLK}^{(17)}$   
For write:  $K = (\text{ADVWrOffTime} - \text{ADVOnTime}) \times (\text{TimeParaGranularity} + 1) \times \text{GPMC\_FCLK}^{(17)}$
  - (17) GPMC\_FCLK is general-purpose memory controller internal functional clock period in ns.
  - (18) Related to the GPMC\_CLK output clock maximum and minimum frequencies programmable in the GPMC module by setting the GPMC\_CONFIG1\_*i* configuration register bit field GPMCFCLKDIVIDER.
  - (19) For div\_by\_1\_mode:
    - GPMC\_CONFIG1\_*i* register: GPMCFCLKDIVIDER = 0h:
      - GPMC\_CLK frequency = GPMC\_FCLK frequency
    - CTRLMMR\_GPMC\_CLKSEL[1-0] CLK\_SEL = 01 = PER1\_PLL\_CLKOUT / 3 = 300 / 3 = 100 MHz
    - GPMC\_CONFIG1\_*i* Register: TIMEPARAGRANULARITY = 0h = x1 latencies (affecting RD/WRCYCLETIME, RD/WRACCESSTIME, PAGEBURSTACCESSTIME, CSONTIME, CSRD/WROFFTIME, ADVONTIME, ADVRD/WROFFTIME, OEONTIME, OEOFFTIME, WEONTIME, WEOFFTIME, CYCLE2CYCLEDELAY, BUSTURNAROUND, TIMEOUTSTARTVALUE, WRDATAONADMUXBUS)
- For no extra\_delay:
- GPMC\_CONFIG2\_*i* Register: CSEXTRADELAY = 0h = CS*n* Timing control signal is not delayed
  - GPMC\_CONFIG4\_*i* Register: WEEEXTRADELAY = 0h = nWE timing control signal is not delayed
  - GPMC\_CONFIG4\_*i* Register: OEEXTRADELAY = 0h = nOE timing control signal is not delayed
  - GPMC\_CONFIG3\_*i* Register: ADVEXTRADELAY = 0h = nADV timing control signal is not delayed
- (20) For 100 MHz:
  - CTRLMMR\_GPMC\_CLKSEL[1-0] CLK\_SEL = 01 = MAIN\_PLL2\_HSDIV1\_CLKOUT / 3
- For 133 MHz:
- CTRLMMR\_GPMC\_CLKSEL[1-0] CLK\_SEL = 00 = MAIN\_PLL0\_HSDIV3\_CLKOUT

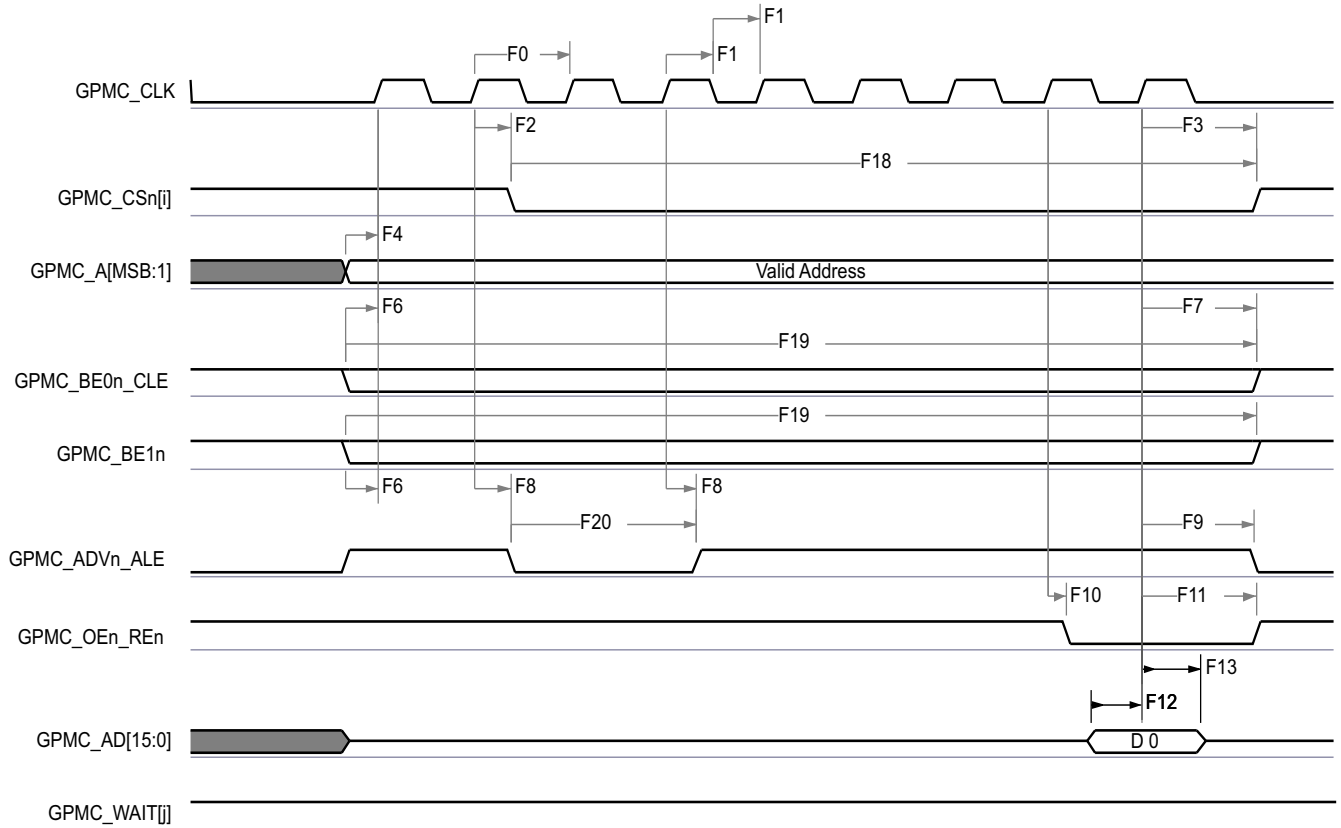

GPMC\_01

- A. In GPMC\_CSn[i], i is equal to 0, 1, 2 or 3.
- B. In GPMC\_WAIT[j], j is equal to 0, 1, 2, or 3.

**图 7-51. GPMC and NOR Flash — Synchronous Single Read (GPMCFCLKDIVIDER = 0)**

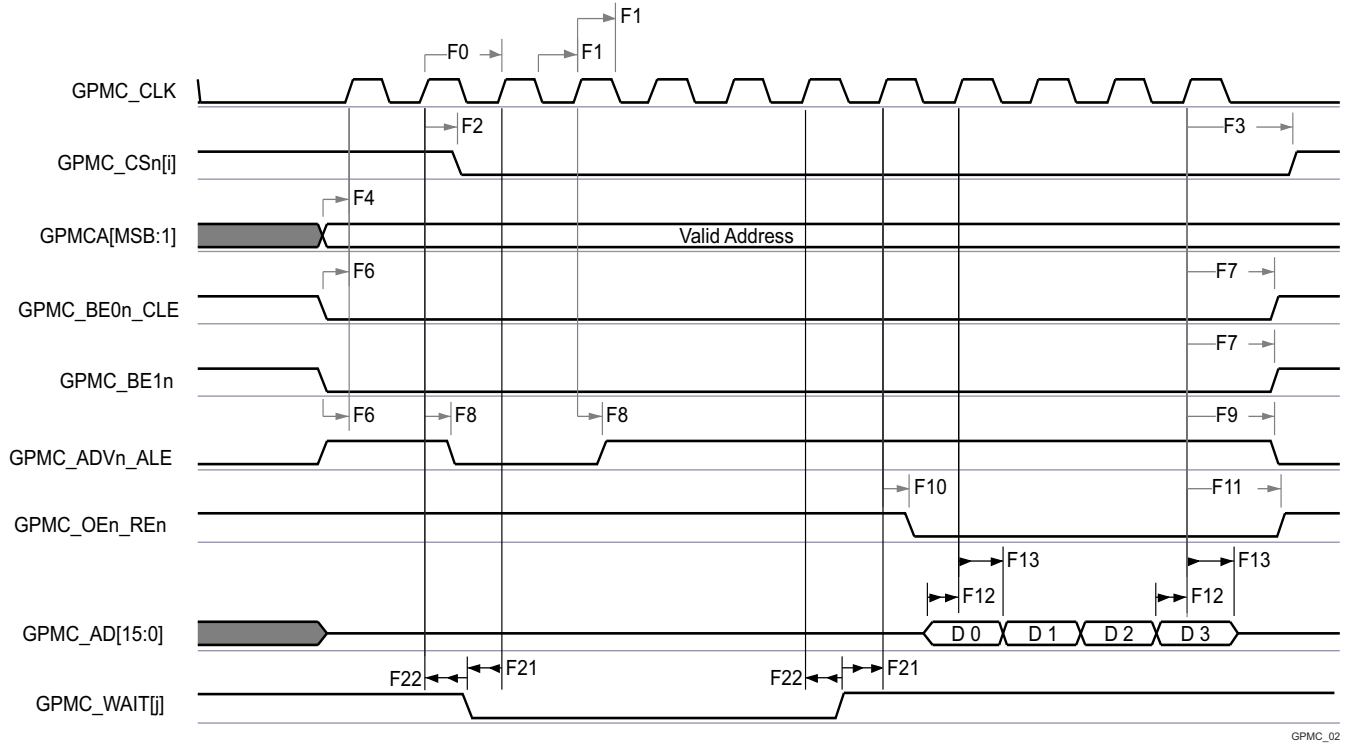

GPMC\_02

- A. In GPMC\_CS[n], i is equal to 0, 1, 2 or 3.
- B. In GPMC\_WAIT[j], j is equal to 0, 1, 2, or 3.

**图 7-52. GPMC and NOR Flash — Synchronous Burst Read — 4x16 - bit (GPMCCLKDIVIDER = 0)**

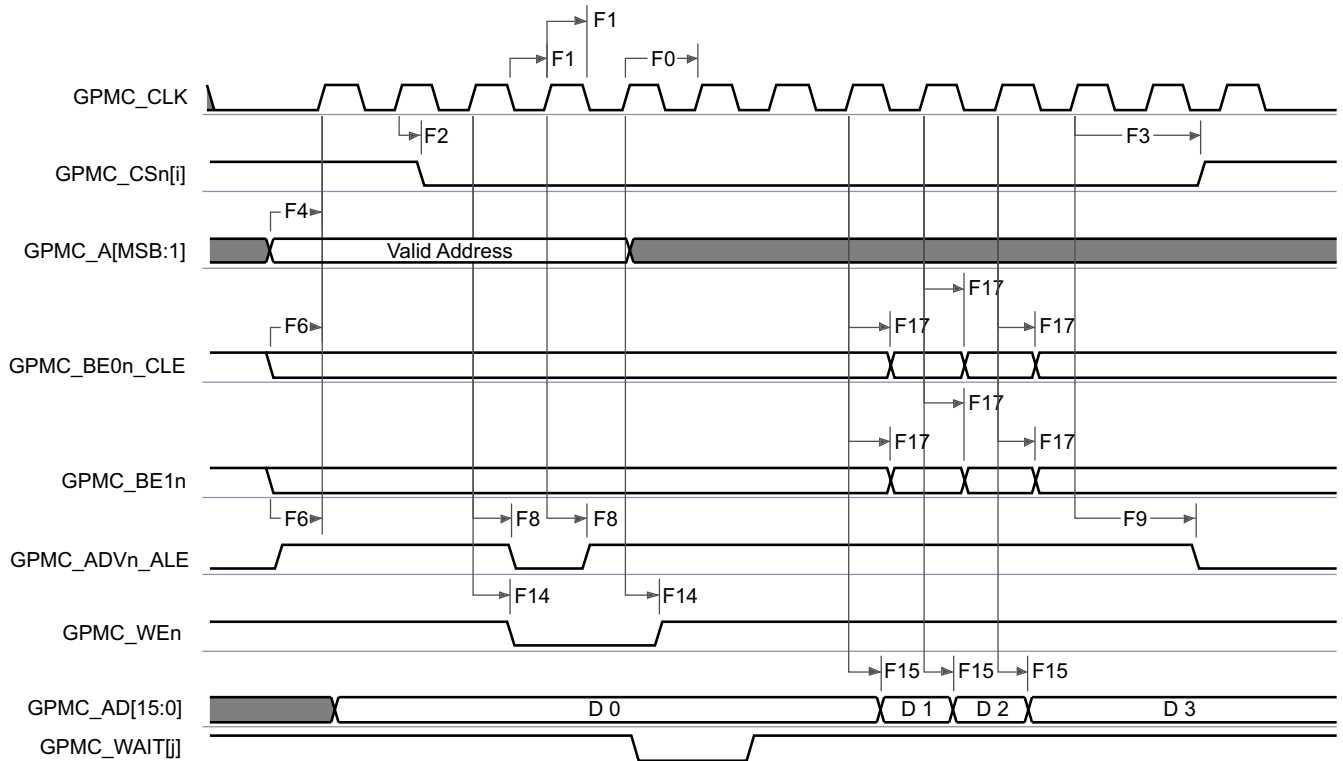

GPMC\_03

- A. In GPMC\_CS[n], i is equal to 0, 1, 2 or 3.

B. In GPMC\_WAIT[j], j is equal to 0, 1, 2, or 3.

图 7-53. GPMC and NOR Flash—Synchronous Burst Write (GPMCFCLKDIVIDER = 0)

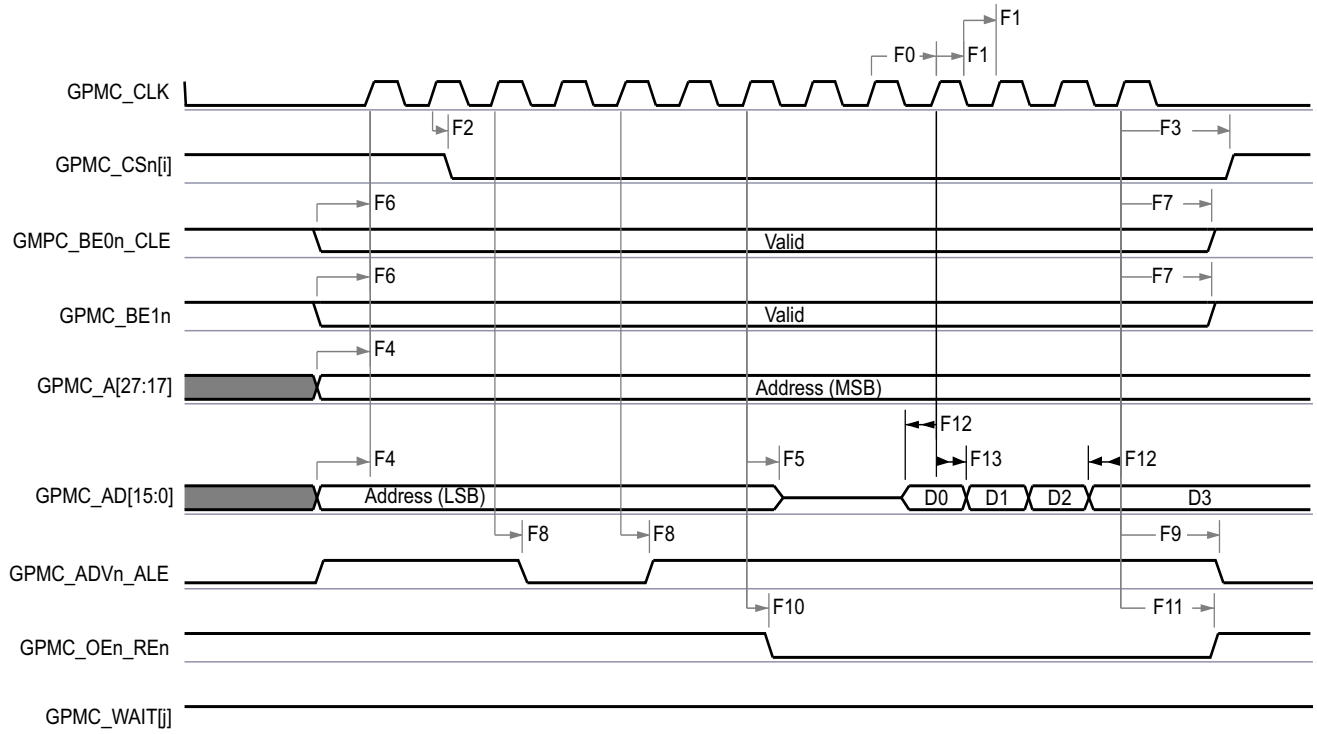

GPMC\_04

A. In GPMC\_CSn[i], i is equal to 0, 1, 2 or 3.

B. In GPMC\_WAIT[j], j is equal to 0, 1, 2, or 3.

图 7-54. GPMC and Multiplexed NOR Flash — Synchronous Burst Read

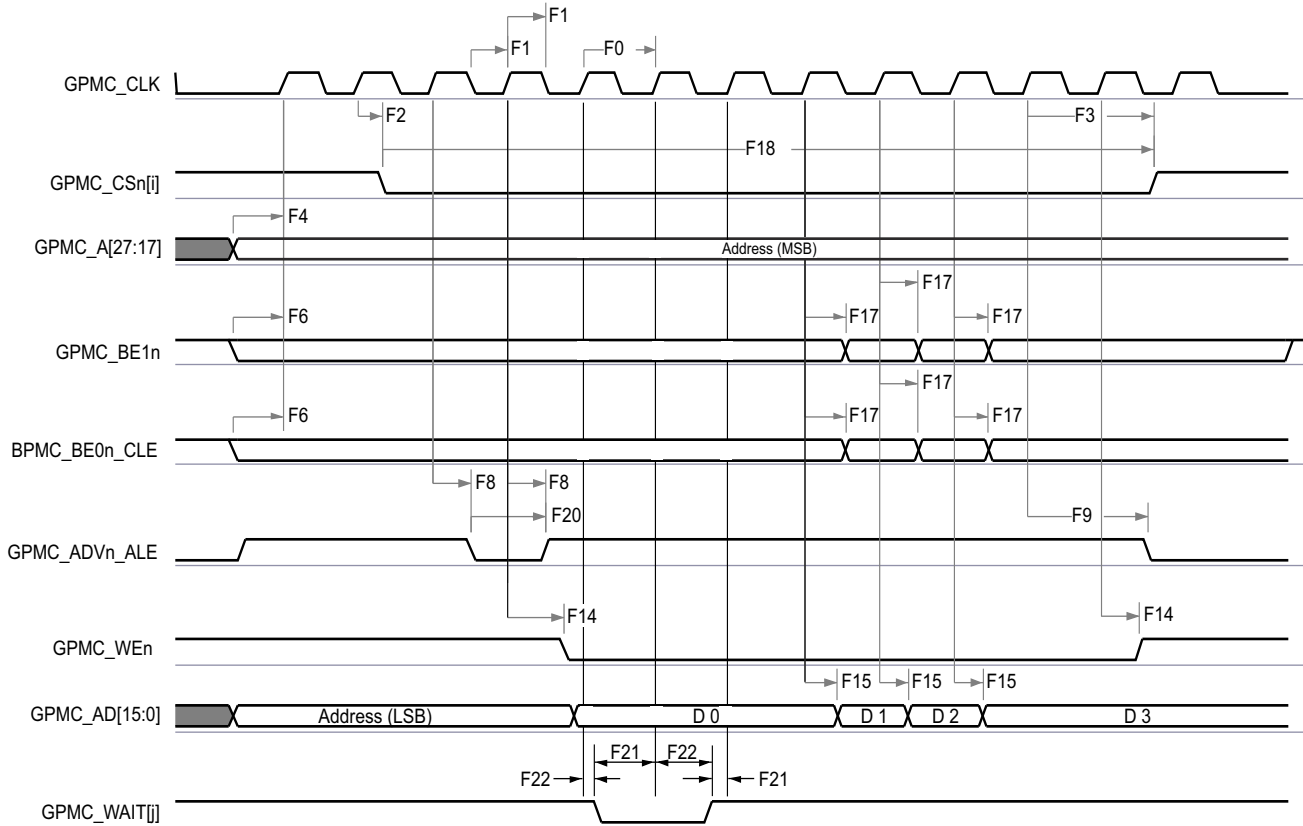

GPMC\_05

- A. In GPMC\_CS[n][i], i is equal to 0, 1, 2 or 3.
- B. In GPMC\_WAIT[j], j is equal to 0, 1, 2, or 3.

**图 7-55. GPMC and Multiplexed NOR Flash — Synchronous Burst Write**

**7.10.5.10.2 GPMC and NOR Flash — Asynchronous Mode**

节 7.10.5.10.2.1 和 节 7.10.5.10.2.2 assume testing over the recommended operating conditions and electrical characteristic conditions below (see 图 7-56 through 图 7-61).

**7.10.5.10.2.1 GPMC and NOR Flash Timing Requirements - Asynchronous Mode**

NO.			MODE <sup>(7)</sup>	MIN	MAX	UNIT
FA5 <sup>(1)</sup>	t <sub>acc(d)</sub>	Data access time	div_by_1_mode ; GPMC_FCLK_MUX; TIMEPARAGRANULARITY_X 1		H <sup>(5)</sup>	ns
FA20 <sup>(2)</sup>	t <sub>acc1-pgmode(d)</sub>	Page mode successive data access time	div_by_1_mode ; GPMC_FCLK_MUX; TIMEPARAGRANULARITY_X 1		P <sup>(4)</sup>	ns
FA21 <sup>(3)</sup>	t <sub>acc2-pgmode(d)</sub>	Page mode first data access time	div_by_1_mode ; GPMC_FCLK_MUX; TIMEPARAGRANULARITY_X 1		H <sup>(5)</sup>	ns

- (1) The FA5 parameter illustrates the amount of time required to internally sample input data. It is expressed in number of GPMC functional clock cycles. From start of read cycle and after FA5 functional clock cycles, input data is internally sampled by active functional clock edge. FA5 value must be stored inside the AccessTime register bit field.
- (2) The FA20 parameter illustrates amount of time required to internally sample successive input page data. It is expressed in number of GPMC functional clock cycles. After each access to input page data, next input page data is internally sampled by active functional clock edge after FA20 functional clock cycles. The FA20 value must be stored in the PageBurstAccessTime register bit field.

- (3) The FA21 parameter illustrates amount of time required to internally sample first input page data. It is expressed in number of GPMC functional clock cycles. From start of read cycle and after FA21 functional clock cycles, first input page data is internally sampled by active functional clock edge. FA21 value must be stored inside the AccessTime register bit field.
- (4)  $P = \text{PageBurstAccessTime} \times (\text{TimeParaGranularity} + 1) \times \text{GPMC\_FCLK}^{(6)}$
- (5)  $H = \text{AccessTime} \times (\text{TimeParaGranularity} + 1) \times \text{GPMC\_FCLK}^{(6)}$
- (6) GPMC\_FCLK is general-purpose memory controller internal functional clock period in ns.
- (7) For div\_by\_1\_mode:
- GPMC\_CONFIG1\_i Register: GPMCFCLKDIVIDER = 0h:
    - GPMC\_CLK frequency = GPMC\_FCLK frequency
  - CTRLMMR\_GPMC\_CLKSEL[1-0] CLK\_SEL = 00 = CPSWHSIV\_CLKOUT3 = 2000/15 = 133.33 MHz
  - GPMC\_CONFIG1\_i Register: TIMEPARAGRANULARITY = 0h = x1 latencies (affecting RD/WRCYCLETIME, RD/WRACCESSTIME, PAGEBURSTACCESSTIME, CSONTIME, CSRD/WROFFTIME, ADVONTIME, ADVRD/WROFFTIME, OEONTIME, OEOFFTIME, WEONTIME, WEOFFTIME, CYCLE2CYCLEDELAY, BUSTURNAROUND, TIMEOUTSTARTVALUE, WRDATAONADMUXBUS)

### 7.10.5.10.2.2 GPMC and NOR Flash Switching Characteristics - Asynchronous Mode

NO.	PARAMETER	DESCRIPTION	MODE <sup>(15)</sup>	MIN	MAX	UNIT
				133 MHz <sup>(16)</sup>		
FA0	$t_{w(\text{be}[x]nV)}$	Pulse duration, output lower-byte enable and command latch enable GPMC_BE0n_CLE, output upper-byte enable GPMC_BE1n valid time	Read		N <sup>(12)</sup>	ns
			Write		N <sup>(12)</sup>	
FA1	$t_{w(\text{csn}V)}$	Pulse duration, output chip select GPMC_CS <sub>n</sub> [j] <sup>(13)</sup> low	Read		A <sup>(1)</sup>	ns
			Write		A <sup>(1)</sup>	
FA3	$t_{d(\text{csn}V\text{-advn}V)}$	Delay time, output chip select GPMC_CS <sub>n</sub> [j] <sup>(13)</sup> valid to output address valid and address latch enable GPMC_ADV <sub>n</sub> _ALE invalid	Read	B <sup>(2)</sup> - 2.55	B <sup>(2)</sup> + 2.65	ns
			Write	B <sup>(2)</sup> - 2.55	B <sup>(2)</sup> + 2.65	
FA4	$t_{d(\text{csn}V\text{-oen}V)}$	Delay time, output chip select GPMC_CS <sub>n</sub> [j] <sup>(13)</sup> valid to output enable GPMC_OEn_REn invalid (Single read)	div_by_1_mode; GPMC_FCLK_MUX; TIMEPARAGRANULARITY_X1	C <sup>(3)</sup> - 2.55	C <sup>(3)</sup> + 2.65	ns
FA9	$t_{d(aV\text{-csn}V)}$	Delay time, output address GPMC_A[27:1] valid to output chip select GPMC_CS <sub>n</sub> [j] <sup>(13)</sup> valid	div_by_1_mode; GPMC_FCLK_MUX; TIMEPARAGRANULARITY_X1	J <sup>(9)</sup> - 2.55	J <sup>(9)</sup> + 2.65	ns
FA10	$t_{d(\text{be}[x]nV\text{-csn}V)}$	Delay time, output lower-byte enable and command latch enable GPMC_BE0n_CLE, output upper-byte enable GPMC_BE1n valid to output chip select GPMC_CS <sub>n</sub> [j] <sup>(13)</sup> valid	div_by_1_mode; GPMC_FCLK_MUX; TIMEPARAGRANULARITY_X1	J <sup>(9)</sup> - 2.55	J <sup>(9)</sup> + 2.65	ns
FA12	$t_{d(\text{csn}V\text{-advn}V)}$	Delay time, output chip select GPMC_CS <sub>n</sub> [j] <sup>(13)</sup> valid to output address valid and address latch enable GPMC_ADV <sub>n</sub> _ALE valid	div_by_1_mode; GPMC_FCLK_MUX; TIMEPARAGRANULARITY_X1	K <sup>(10)</sup> - 2.55	K <sup>(10)</sup> + 2.65	ns
FA13	$t_{d(\text{csn}V\text{-oen}V)}$	Delay time, output chip select GPMC_CS <sub>n</sub> [j] <sup>(13)</sup> valid to output enable GPMC_OEn_REn valid	div_by_1_mode; GPMC_FCLK_MUX; TIMEPARAGRANULARITY_X1	L <sup>(11)</sup> - 2.55	L <sup>(11)</sup> + 2.65	ns
FA16	$t_{w(a}V)}$	Pulse duration output address GPMC_A[26:1] invalid between 2 successive read and write accesses	div_by_1_mode; GPMC_FCLK_MUX; TIMEPARAGRANULARITY_X1	G <sup>(7)</sup>		ns
FA18	$t_{d(\text{csn}V\text{-oen}V)}$	Delay time, output chip select GPMC_CS <sub>n</sub> [j] <sup>(13)</sup> valid to output enable GPMC_OEn_REn invalid (Burst read)	div_by_1_mode; GPMC_FCLK_MUX; TIMEPARAGRANULARITY_X1	I <sup>(8)</sup> - 2.55	I <sup>(8)</sup> + 2.65	ns

NO.	PARAMETER	DESCRIPTION	MODE <sup>(15)</sup>	MIN	MAX	UNIT
				133 MHz <sup>(16)</sup>		
FA20	t <sub>w(av)</sub>	Pulse duration, output address GPMC_A[27:1] valid - 2nd, 3rd, and 4th accesses	div_by_1_mode; GPMC_FCLK_MUX; TIMEPARAGRANULARITY_X1	D <sup>(4)</sup>		ns
FA25	t <sub>d(csnV-wenV)</sub>	Delay time, output chip select GPMC_CS <i>n</i> [ <i>j</i> ] <sup>(13)</sup> valid to output write enable GPMC_WEn valid	div_by_1_mode; GPMC_FCLK_MUX; TIMEPARAGRANULARITY_X1	E <sup>(5)</sup> - 2.55	E <sup>(5)</sup> + 2.65	ns
FA27	t <sub>d(csnV-wenIV)</sub>	Delay time, output chip select GPMC_CS <i>n</i> [ <i>j</i> ] <sup>(13)</sup> valid to output write enable GPMC_WEn invalid	div_by_1_mode; GPMC_FCLK_MUX; TIMEPARAGRANULARITY_X1	F <sup>(6)</sup> - 2.55	F <sup>(6)</sup> + 2.65	ns
FA28	t <sub>d(wenV-dV)</sub>	Delay time, output write enable GPMC_WEn valid to output data GPMC_AD[15:0] valid	div_by_1_mode; GPMC_FCLK_MUX; TIMEPARAGRANULARITY_X1	2.65		ns
FA29	t <sub>d(dV-csnV)</sub>	Delay time, output data GPMC_AD[15:0] valid to output chip select GPMC_CS <i>n</i> [ <i>j</i> ] <sup>(13)</sup> valid	div_by_1_mode; GPMC_FCLK_MUX; TIMEPARAGRANULARITY_X1	J <sup>(9)</sup> - 2.55	J <sup>(9)</sup> + 2.65	ns
FA37	t <sub>d(oenV-alV)</sub>	Delay time, output enable GPMC_OEn_REn valid to output address GPMC_AD[15:0] phase end	div_by_1_mode; GPMC_FCLK_MUX; TIMEPARAGRANULARITY_X1	2.65		ns

- (1) For single read:  $A = (CSRdOffTime - CSOnTime) \times (TimeParaGranularity + 1) \times GPMC\_FCLK^{(14)}$   
 For single write:  $A = (CSWrOffTime - CSOnTime) \times (TimeParaGranularity + 1) \times GPMC\_FCLK^{(14)}$   
 For burst read:  $A = (CSRdOffTime - CSOnTime + (n - 1) \times PageBurstAccessTime) \times (TimeParaGranularity + 1) \times GPMC\_FCLK^{(14)}$   
 For burst write:  $A = (CSWrOffTime - CSOnTime + (n - 1) \times PageBurstAccessTime) \times (TimeParaGranularity + 1) \times GPMC\_FCLK^{(14)}$   
 with n being the page burst access number
- (2) For reading:  $B = ((ADVrdOffTime - CSOnTime) \times (TimeParaGranularity + 1) + 0.5 \times (ADVExtraDelay - CSEExtraDelay)) \times GPMC\_FCLK^{(14)}$   
 For writing:  $B = ((ADVwrOffTime - CSOnTime) \times (TimeParaGranularity + 1) + 0.5 \times (ADVExtraDelay - CSEExtraDelay)) \times GPMC\_FCLK^{(14)}$
- (3)  $C = ((OEOffTime - CSOnTime) \times (TimeParaGranularity + 1) + 0.5 \times (OEExtraDelay - CSEExtraDelay)) \times GPMC\_FCLK^{(14)}$
- (4)  $D = PageBurstAccessTime \times (TimeParaGranularity + 1) \times GPMC\_FCLK^{(14)}$
- (5)  $E = ((WEOnTime - CSOnTime) \times (TimeParaGranularity + 1) + 0.5 \times (WEEExtraDelay - CSEExtraDelay)) \times GPMC\_FCLK^{(14)}$
- (6)  $F = ((WEOffTime - CSOnTime) \times (TimeParaGranularity + 1) + 0.5 \times (WEEExtraDelay - CSEExtraDelay)) \times GPMC\_FCLK^{(14)}$
- (7)  $G = Cycle2CycleDelay \times GPMC\_FCLK^{(14)}$
- (8)  $I = ((OEOffTime + (n - 1) \times PageBurstAccessTime - CSOnTime) \times (TimeParaGranularity + 1) + 0.5 \times (OEExtraDelay - CSEExtraDelay)) \times GPMC\_FCLK^{(14)}$
- (9)  $J = (CSOnTime \times (TimeParaGranularity + 1) + 0.5 \times CSEExtraDelay) \times GPMC\_FCLK^{(14)}$
- (10)  $K = ((ADVOnTime - CSOnTime) \times (TimeParaGranularity + 1) + 0.5 \times (ADVExtraDelay - CSEExtraDelay)) \times GPMC\_FCLK^{(14)}$
- (11)  $L = ((OEOnTime - CSOnTime) \times (TimeParaGranularity + 1) + 0.5 \times (OEExtraDelay - CSEExtraDelay)) \times GPMC\_FCLK^{(14)}$
- (12) For single read:  $N = RdCycleTime \times (TimeParaGranularity + 1) \times GPMC\_FCLK^{(14)}$   
 For single write:  $N = WrCycleTime \times (TimeParaGranularity + 1) \times GPMC\_FCLK^{(14)}$   
 For burst read:  $N = (RdCycleTime + (n - 1) \times PageBurstAccessTime) \times (TimeParaGranularity + 1) \times GPMC\_FCLK^{(14)}$   
 For burst write:  $N = (WrCycleTime + (n - 1) \times PageBurstAccessTime) \times (TimeParaGranularity + 1) \times GPMC\_FCLK^{(14)}$
- (13) In GPMC\_CS*n*[*j*], i is equal to 0, 1, 2 or 3.
- (14) GPMC\_FCLK is general-purpose memory controller internal functional clock period in ns.
- (15) For div\_by\_1\_mode:
- GPMC\_CONFIG1\_i Register: GPMCFCLKDIVIDER = 0h:
    - GPMC\_CLK frequency = GPMC\_FCLK frequency
  - CTRLMMR\_GPMC\_CLKSEL[1-0] CLK\_SEL = 00 = CPSWHS DIV\_CLKOUT3 = 2000/15 = 133.33 MHz
  - GPMC\_CONFIG1\_i Register: TIMEPARAGRANULARITY = 0h = x1 latencies (affecting RD/WRCYCLETIME, RD/WRACCESSTIME, PAGEBURSTACCESSTIME, CSONTIME, CSRd/WROFFTIME, ADVONTIME, ADVRD/WROFFTIME, OEONTIME, OEOffTIME, WEONTIME, WEOFFTIME, CYCLE2CYCLEDELAY, BUSTURNAROUND, TIMEOUTSTARTVALUE, WRDATAONADMUXBUS)
- (16) For 133 MHz:

- CTRLMMR\_GPMC\_CLKSEL[1-0] CLK\_SEL = 00 = MAIN\_PLL0\_HSDIV3\_CLKOUT

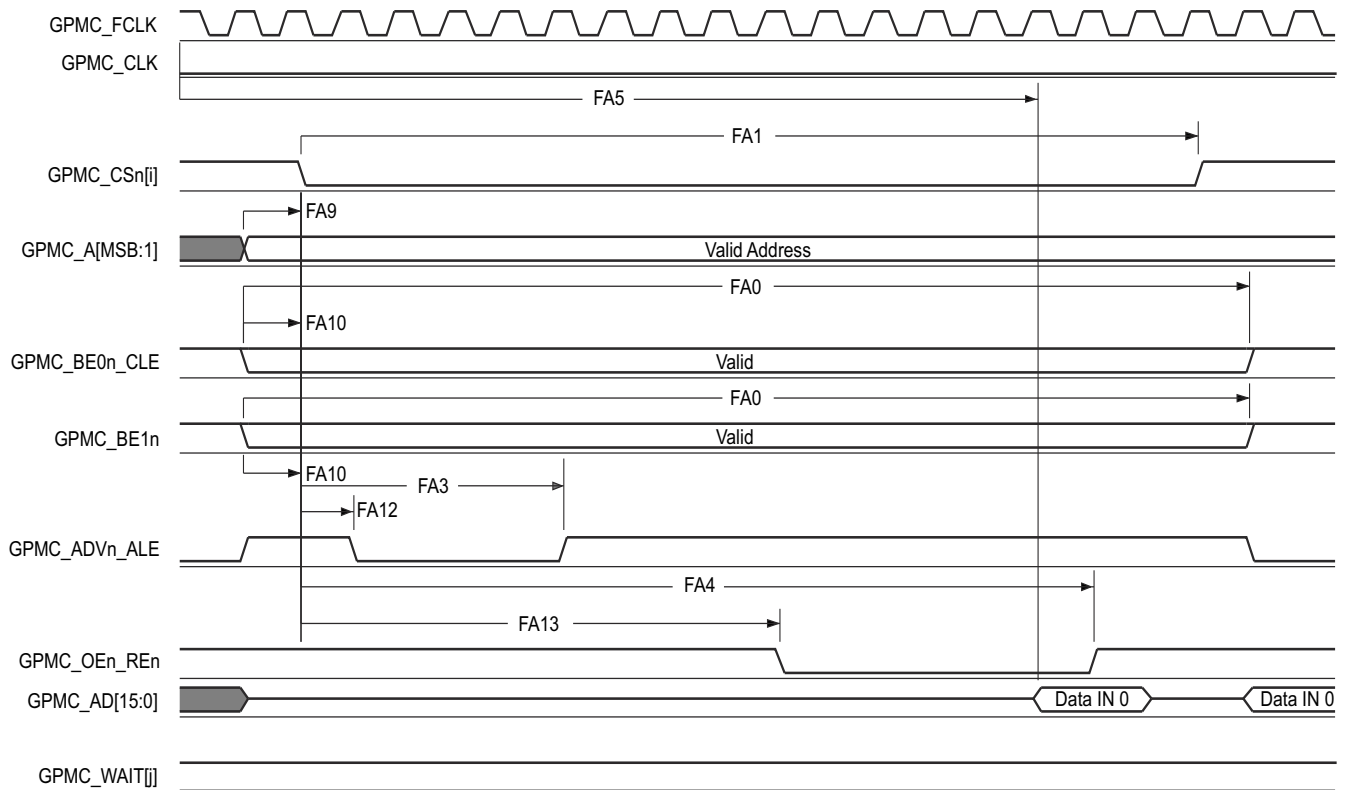

GPMC\_06

- In GPMC\_CS[n][i], i is equal to 0, 1, 2 or 3. In GPMC\_WAIT[j], j is equal to 0, 1, 2, or 3.
- FA5 parameter illustrates amount of time required to internally sample input data. It is expressed in number of GPMC functional clock cycles. From start of read cycle and after FA5 functional clock cycles, input data will be internally sampled by active functional clock edge. FA5 value must be stored inside AccessTime register bits field.
- GPMC\_FCLK is an internal clock (GPMC functional clock) not provided externally.

图 7-56. GPMC and NOR Flash — Asynchronous Read — Single Word

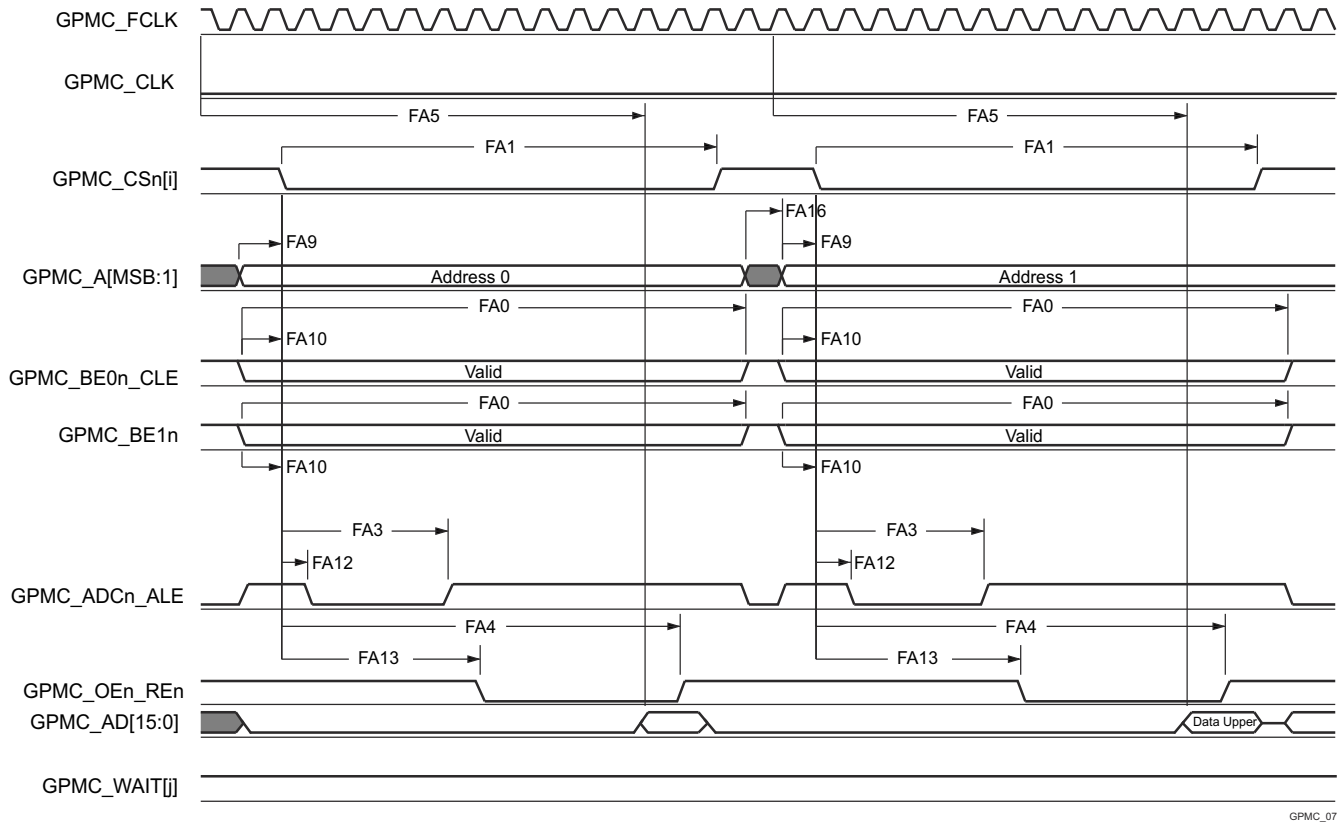

GPMC\_07

- A. In GPMC\_CS*n*[*i*], *i* is equal to 0, 1, 2 or 3. In GPMC\_WAIT[*j*], *j* is equal to 0, 1, 2, or 3.
- B. FA5 parameter illustrates amount of time required to internally sample input data. It is expressed in number of GPMC functional clock cycles. From start of read cycle and after FA5 functional clock cycles, input data will be internally sampled by active functional clock edge. FA5 value must be stored inside AccessTime register bits field.
- C. GPMC\_FCLK is an internal clock (GPMC functional clock) not provided externally.

**图 7-57. GPMC and NOR Flash — Asynchronous Read — 32 - Bit**

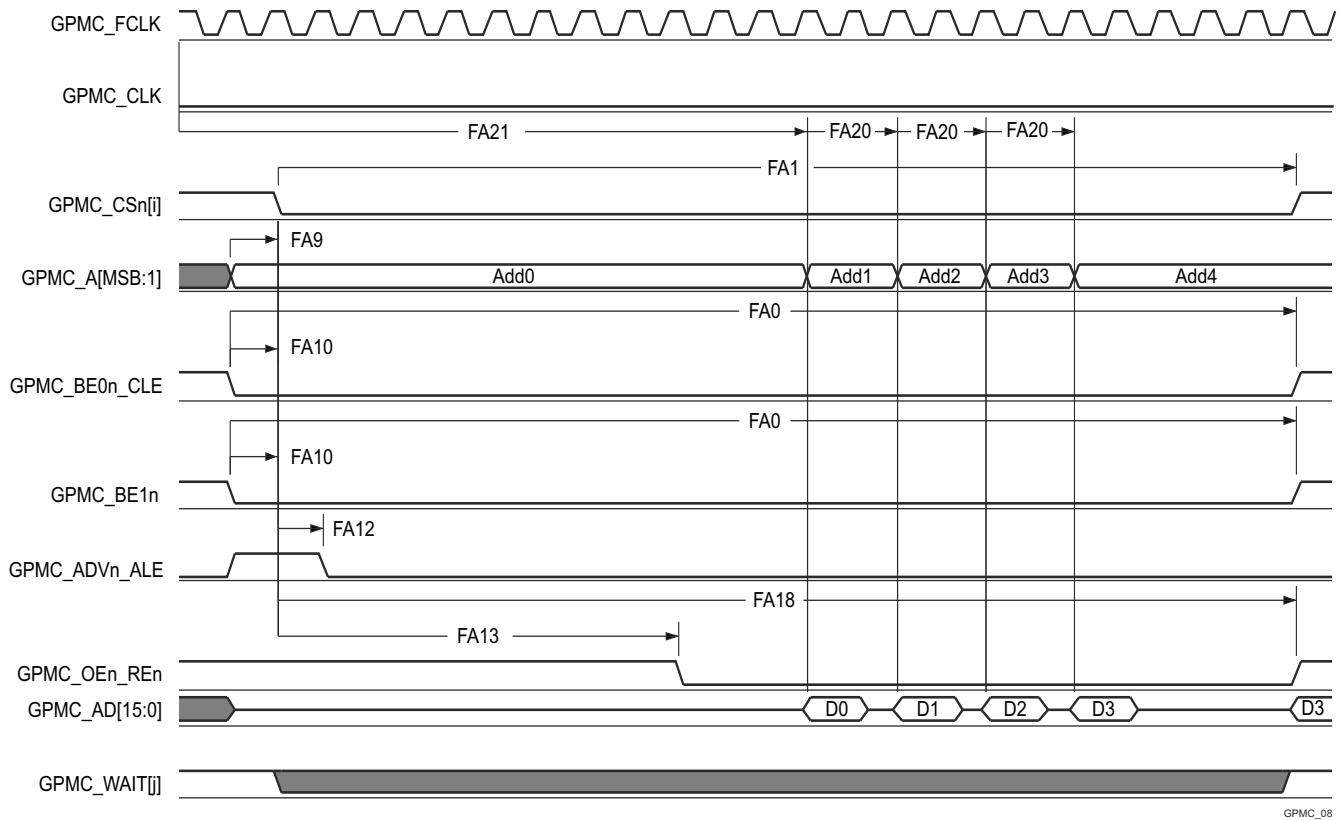

GPMC\_08

- A. In GPMC\_CS*n*[*i*], *i* is equal to 0, 1, 2 or 3. In GPMC\_WAIT[j], *j* is equal to 0, 1, 2, or 3.
- B. FA21 parameter illustrates amount of time required to internally sample first input page data. It is expressed in number of GPMC functional clock cycles. From start of read cycle and after FA21 functional clock cycles, first input page data will be internally sampled by active functional clock edge. FA21 calculation must be stored inside AccessTime register bits field.
- C. FA20 parameter illustrates amount of time required to internally sample successive input page data. It is expressed in number of GPMC functional clock cycles. After each access to input page data, next input page data will be internally sampled by active functional clock edge after FA20 functional clock cycles. FA20 is also the duration of address phases for successive input page data (excluding first input page data). FA20 value must be stored in PageBurstAccessTime register bits field.
- D. GPMC\_FCLK is an internal clock (GPMC functional clock) not provided externally.

图 7-58. GPMC and NOR Flash — Asynchronous Read — Page Mode 4x16 - Bit

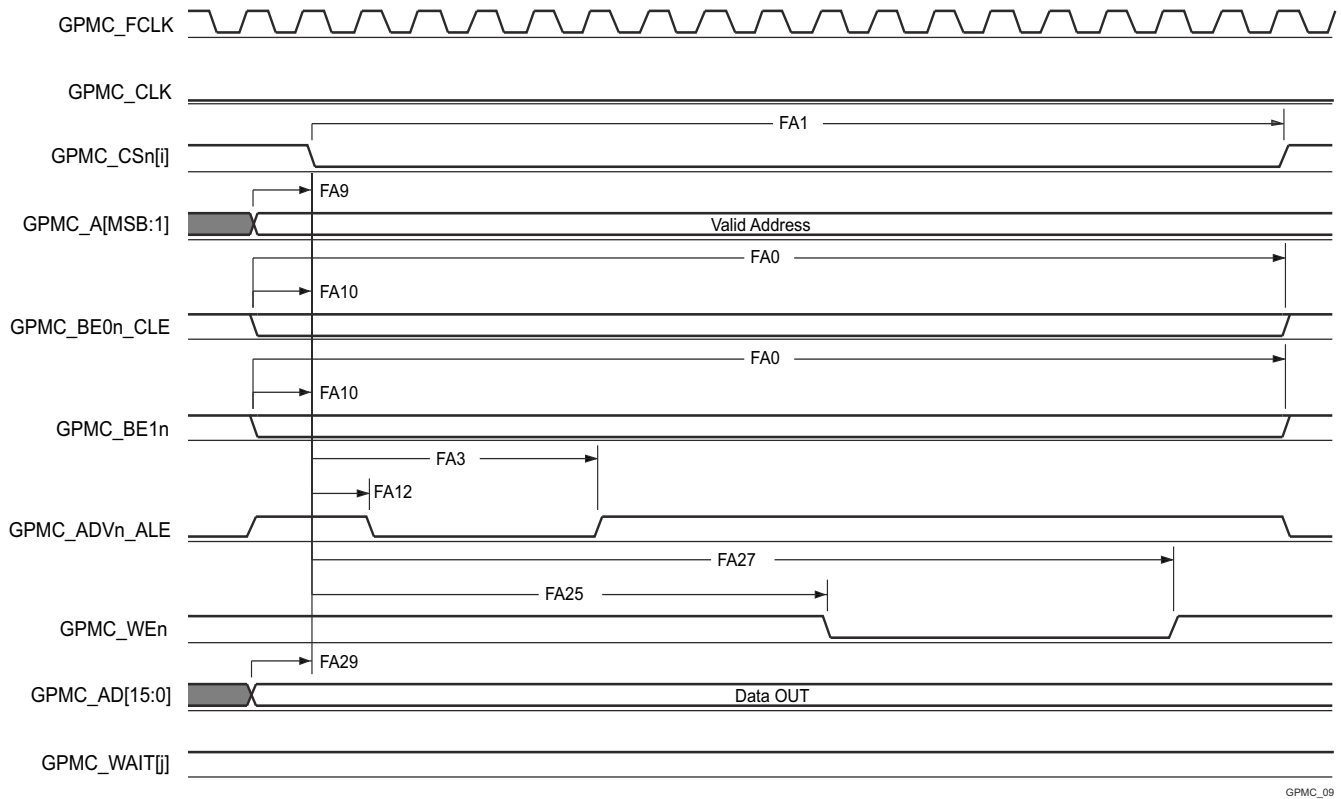

GPMC\_09

A. In GPMC\_CS*n*[*i*], *i* is equal to 0, 1, 2 or 3. In GPMC\_WAIT[j], *j* is equal to 0, 1, 2, or 3.

**图 7-59. GPMC and NOR Flash — Asynchronous Write — Single Word**

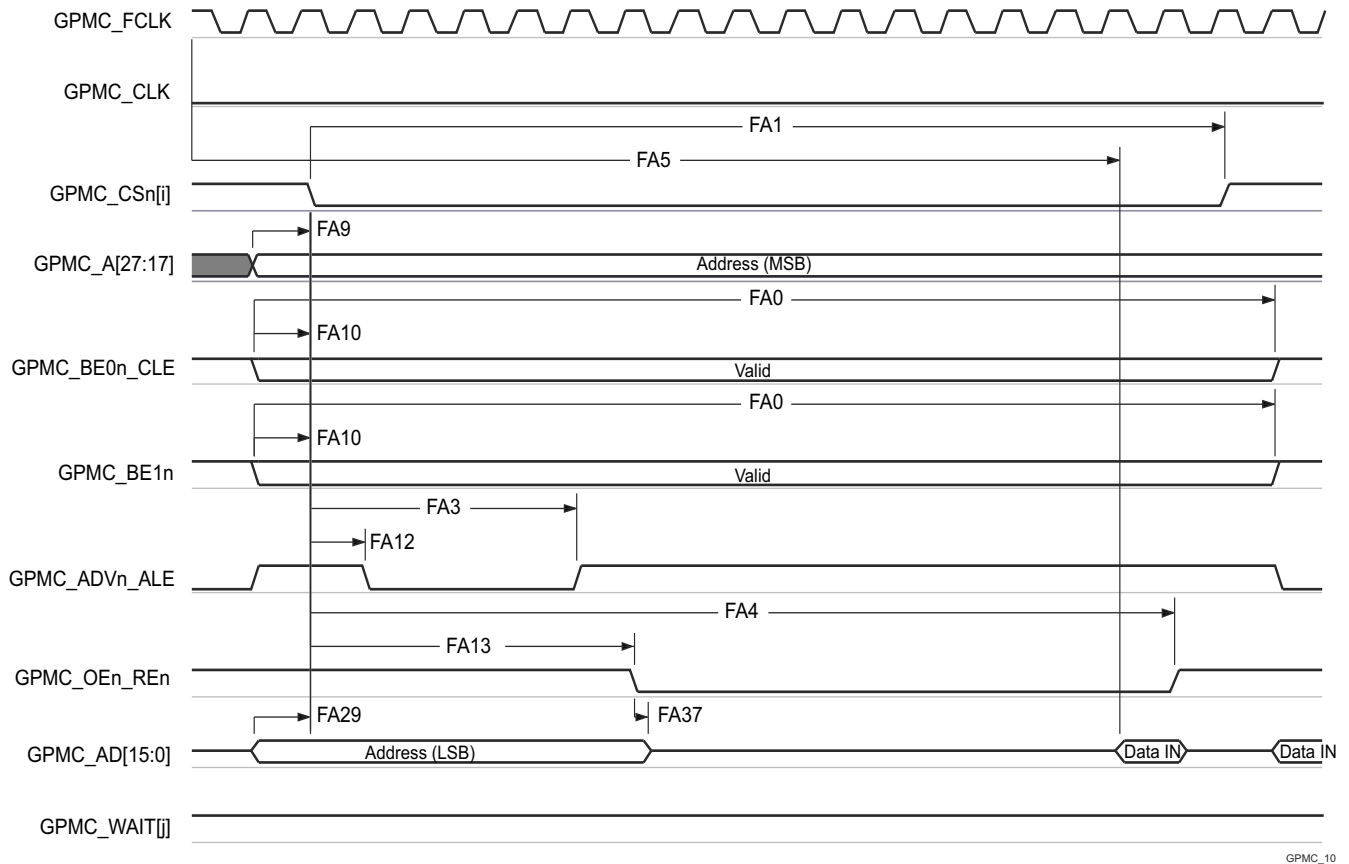

GPMC\_10

- A. In GPMC\_CS[n][i], i is equal to 0, 1, 2 or 3. In GPMC\_WAIT[j], j is equal to 0, 1, 2, or 3.
- B. FA5 parameter illustrates amount of time required to internally sample input data. It is expressed in number of GPMC functional clock cycles. From start of read cycle and after FA5 functional clock cycles, input data will be internally sampled by active functional clock edge. FA5 value must be stored inside AccessTime register bits field.
- C. GPMC\_FCLK is an internal clock (GPMC functional clock) not provided externally.

图 7-60. GPMC and Multiplexed NOR Flash — Asynchronous Read — Single Word

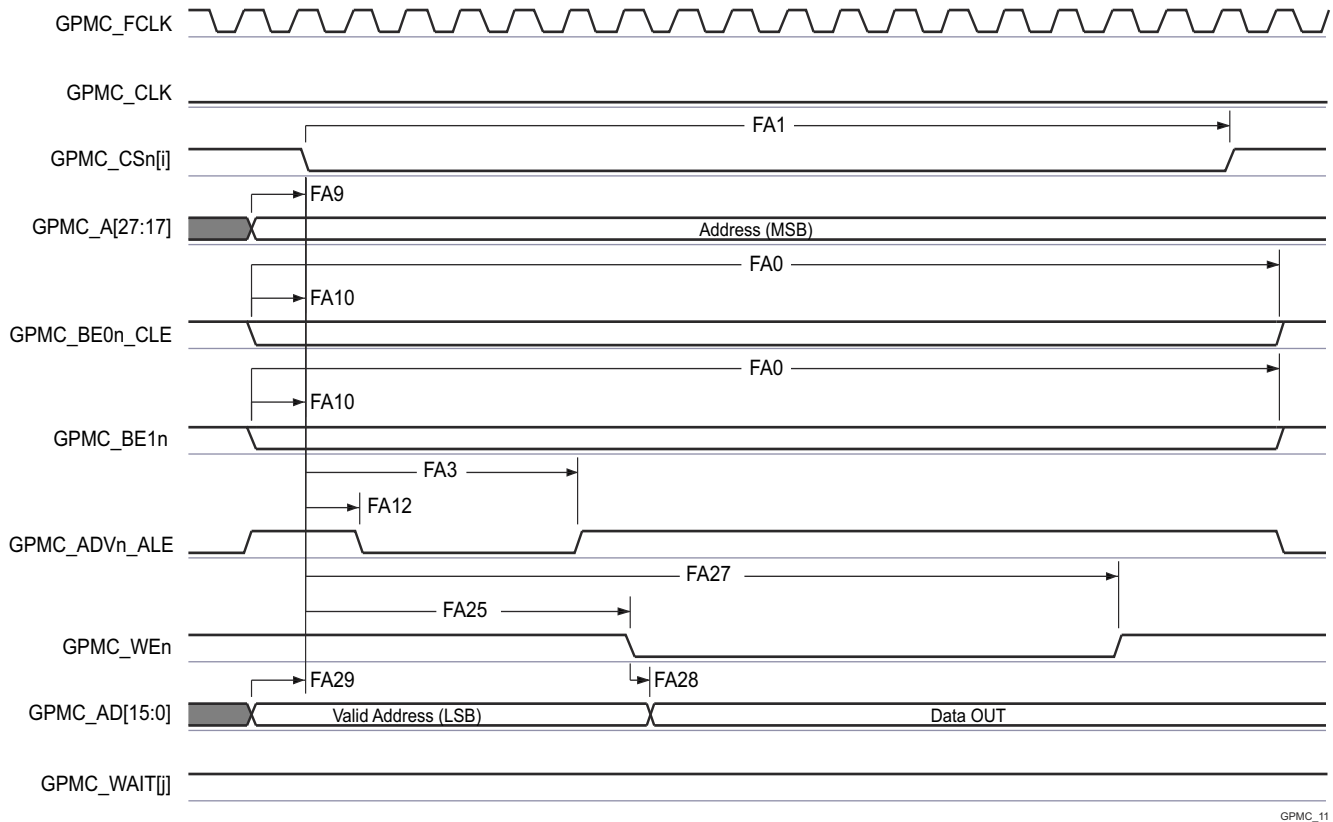

GPMC\_11

A. In GPMC\_CSn[i], i is equal to 0, 1, 2 or 3. In GPMC\_WAIT[j], j is equal to 0, 1, 2, or 3.

**图 7-61. GPMC and Multiplexed NOR Flash — Asynchronous Write — Single Word**

### 7.10.5.10.3 GPMC and NAND Flash — Asynchronous Mode

节 7.10.5.10.3.1 和 节 7.10.5.10.3.2 assume testing over the recommended operating conditions and electrical characteristic conditions below (see 图 7-62 through 图 7-65).

#### 7.10.5.10.3.1 GPMC and NAND Flash Timing Requirements - Asynchronous Mode

NO.		MODE <sup>(4)</sup>	MIN	MAX	UNIT
			133 MHz <sup>(5)</sup>		
GNF12 <sup>(1)</sup>	$t_{acc(d)}$ Access time, input data GPMC_AD[15:0] <sup>(3)</sup>	div_by_1_mode; GPMC_FCLK_MUX; TIMEPARAGRANULARITY_X1	J <sup>(2)</sup>		ns

(1) The GNF12 parameter illustrates the amount of time required to internally sample input data. It is expressed in number of GPMC functional clock cycles. From start of the read cycle and after GNF12 functional clock cycles, input data is internally sampled by the active functional clock edge. The GNF12 value must be stored inside AccessTime register bit field.

(2)  $J = \text{AccessTime} \times (\text{TimeParaGranularity} + 1) \times \text{GPMC\_FCLK}^{(3)}$

(3) GPMC\_FCLK is general-purpose memory controller internal functional clock period in ns.

(4) For div\_by\_1\_mode:

- GPMC\_CONFIG1\_i Register: GPMCFCLKDIVIDER = 0h:
  - GPMC\_CLK frequency = GPMC\_FCLK frequency
- CTRLMMR\_GPMC\_CLKSEL[1-0] CLK\_SEL = 00 = CPSWHS DIV\_CLKOUT3 = 2000/15 = 133.33 MHz
- GPMC\_CONFIG1\_i Register: TIMEPARAGRANULARITY = 0h = x1 latencies (affecting RD/WRCYCLETIME, RD/WRACCESSTIME, PAGEBURSTACCESSTIME, CSONTIME, CSRD/WROFFTIME, ADVONTIME, ADVRD/WROFFTIME, OEONTIME, OEOFFTIME, WEONTIME, WEOFFTIME, CYCLE2CYCLEDELAY, BUSTURNAROUND, TIMEOUTSTARTVALUE, WRDATAONADMUXBUS)

(5) For 133 MHz:

- CTRLMMR\_GPMC\_CLKSEL[1-0] CLK\_SEL = 00 = MAIN\_PLL0\_HSDIV3\_CLKOUT

#### 7.10.5.10.3.2 GPMC and NAND Flash Switching Characteristics - Asynchronous Mode

NO.	PARAMETER	MODE <sup>(15)</sup>	MIN	MAX	UNIT
			133 MHz <sup>(16)</sup>		
GNF0	$t_{w(wenV)}$ Pulse duration, output write enable GPMC_WEn valid	div_by_1_mode; GPMC_FCLK_MUX; TIMEPARAGRANULARITY_X1	A <sup>(1)</sup>		ns
GNF1	$t_{d(csnV-wenV)}$ Delay time, output chip select GPMC_CS <i>n</i> [ <i>i</i> ] <sup>(13)</sup> valid to output write enable GPMC_WEn valid	div_by_1_mode; GPMC_FCLK_MUX; TIMEPARAGRANULARITY_X1	B <sup>(2)</sup> - 2.55	B <sup>(2)+</sup> 2.65	ns
GNF2	$t_{w(cleH-wenV)}$ Delay time, output lower-byte enable and command latch enable GPMC_BE0 <i>n</i> _CLE high to output write enable GPMC_WEn valid	div_by_1_mode; GPMC_FCLK_MUX; TIMEPARAGRANULARITY_X1	C <sup>(3)</sup> - 2.55	C <sup>(3)+</sup> 2.65	ns
GNF3	$t_{w(wenV-dV)}$ Delay time, output data GPMC_AD[15:0] valid to output write enable GPMC_WEn valid	div_by_1_mode; GPMC_FCLK_MUX; TIMEPARAGRANULARITY_X1	D <sup>(4)</sup> - 2.55	D <sup>(4)+</sup> 2.65	ns
GNF4	$t_{w(wenIV-dIV)}$ Delay time, output write enable GPMC_WEn invalid to output data GPMC_AD[15:0] invalid	div_by_1_mode; GPMC_FCLK_MUX; TIMEPARAGRANULARITY_X1	E <sup>(5)</sup> - 2.55	E <sup>(5)+</sup> 2.65	ns
GNF5	$t_{w(wenIV-cleIV)}$ Delay time, output write enable GPMC_WEn invalid to output lower-byte enable and command latch enable GPMC_BE0 <i>n</i> _CLE invalid	div_by_1_mode; GPMC_FCLK_MUX; TIMEPARAGRANULARITY_X1	F <sup>(6)</sup> - 2.55	F <sup>(6)+</sup> 2.65	ns

NO.	PARAMETER		MODE <sup>(15)</sup>	MIN	MAX	UNIT
				133 MHz <sup>(16)</sup>		
GNF6	$t_{w(wenIV-CSn[i])}$	Delay time, output write enable GPMC_WEn invalid to output chip select GPMC_CS <i>n</i> [ <i>i</i> ] <sup>(13)</sup> invalid	div_by_1_mode; GPMC_FCLK_MUX; TIMEPARAGRANULARITY_X1	G <sup>(7)</sup> - 2.55	G <sup>(7)+</sup> 2.65	ns
GNF7	$t_{w(aleH-wenV)}$	Delay time, output address valid and address latch enable GPMC_ADV <i>n</i> _ALE high to output write enable GPMC_WEn valid	div_by_1_mode; GPMC_FCLK_MUX; TIMEPARAGRANULARITY_X1	C <sup>(3)</sup> - 2.55	C <sup>(3)+</sup> 2.65	ns
GNF8	$t_{w(wenIV-aleIV)}$	Delay time, output write enable GPMC_WEn invalid to output address valid and address latch enable GPMC_ADV <i>n</i> _ALE invalid	div_by_1_mode; GPMC_FCLK_MUX; TIMEPARAGRANULARITY_X1	F <sup>(6)</sup> - 2.55	F <sup>(6)+</sup> 2.65	ns
GNF9	$t_{c(wen)}$	Cycle time, write	div_by_1_mode; GPMC_FCLK_MUX; TIMEPARAGRANULARITY_X1		H <sup>(8)</sup>	ns
GNF10	$t_{d(csnV-oenV)}$	Delay time, output chip select GPMC_CS <i>n</i> [ <i>i</i> ] <sup>(13)</sup> valid to output enable GPMC_OEn_RE <i>n</i> valid	div_by_1_mode; GPMC_FCLK_MUX; TIMEPARAGRANULARITY_X1	I <sup>(9)</sup> - 2.55	I <sup>(9)+</sup> 2.65	ns
GNF13	$t_{w(oenV)}$	Pulse duration, output enable GPMC_OEn_RE <i>n</i> valid	div_by_1_mode; GPMC_FCLK_MUX; TIMEPARAGRANULARITY_X1		K <sup>(10)</sup>	ns
GNF14	$t_{c(oen)}$	Cycle time, read	div_by_1_mode; GPMC_FCLK_MUX; TIMEPARAGRANULARITY_X1		L <sup>(11)</sup>	ns
GNF15	$t_{w(oenIV-CSn[i])}$	Delay time, output enable GPMC_OEn_RE <i>n</i> invalid to output chip select GPMC_CS <i>n</i> [ <i>i</i> ] <sup>(13)</sup> invalid	div_by_1_mode;	M <sup>(12)</sup> - 2.55	M <sup>(12)+</sup> 2.65	ns

- (1)  $A = (WEOffTime - WEOnTime) \times (TimeParaGranularity + 1) \times GPMC\_FCLK^{(14)}$   
 (2)  $B = ((WEOnTime - CSOnTime) \times (TimeParaGranularity + 1) + 0.5 \times (WEEExtraDelay - CSEExtraDelay)) \times GPMC\_FCLK^{(14)}$   
 (3)  $C = ((WEOnTime - ADVOnTime) \times (TimeParaGranularity + 1) + 0.5 \times (WEEExtraDelay - ADVExtraDelay)) \times GPMC\_FCLK^{(14)}$   
 (4)  $D = (WEOnTime \times (TimeParaGranularity + 1) + 0.5 \times WEEExtraDelay) \times GPMC\_FCLK^{(14)}$   
 (5)  $E = ((WrCycleTime - WEOffTime) \times (TimeParaGranularity + 1) - 0.5 \times WEEExtraDelay) \times GPMC\_FCLK^{(14)}$   
 (6)  $F = ((ADVWrOffTime - WEOffTime) \times (TimeParaGranularity + 1) + 0.5 \times (ADVExtraDelay - WEEExtraDelay)) \times GPMC\_FCLK^{(14)}$   
 (7)  $G = ((CSWrOffTime - WEOffTime) \times (TimeParaGranularity + 1) + 0.5 \times (CSEExtraDelay - WEEExtraDelay)) \times GPMC\_FCLK^{(14)}$   
 (8)  $H = WrCycleTime \times (1 + TimeParaGranularity) \times GPMC\_FCLK^{(14)}$   
 (9)  $I = ((OEOntime - CSOnTime) \times (TimeParaGranularity + 1) + 0.5 \times (OEEExtraDelay - CSEExtraDelay)) \times GPMC\_FCLK^{(14)}$   
 (10)  $K = (OEOffTime - OEOnTime) \times (1 + TimeParaGranularity) \times GPMC\_FCLK^{(14)}$   
 (11)  $L = RdCycleTime \times (1 + TimeParaGranularity) \times GPMC\_FCLK^{(14)}$   
 (12)  $M = ((CSRdOffTime - OEOffTime) \times (TimeParaGranularity + 1) + 0.5 \times (CSEExtraDelay - OEEExtraDelay)) \times GPMC\_FCLK^{(14)}$   
 (13) In GPMC\_CS*n*[*i*], *i* is equal to 0, 1, 2 or 3.  
 (14) GPMC\_FCLK is general-purpose memory controller internal functional clock period in ns.  
 (15) For div\_by\_1\_mode:

- GPMC\_CONFIG1\_i Register: GPMCFCLKDIVIDER = 0h:  
 - GPMC\_CLK frequency = GPMC\_FCLK frequency

For GPMC\_FCLK\_MUX:

- CTRLMMR\_GPMC\_CLKSEL[1-0] CLK\_SEL = 00 = CPSWHS DIV\_CLKOUT3 = 2000/15 = 133.33 MHz

For TIMEPARAGRANULARITY\_X1:

- GPMC\_CONFIG1\_i Register: TIMEPARAGRANULARITY = 0h = x1 latencies (affecting RD/WRCYCLETIME, RD/WRACCESSTIME, PAGEBURSTACCESSTIME, CSONTIME, CSRd/WROFFTIME, ADVONTIME, ADVRD/WROFFTIME, OEONTIME, OEOFFTIME, WEONTIME, WEOFFTIME, CYCLE2CYCLEDELAY, BUSTURNAROUND, TIMEOUTSTARTVALUE, WRDATAONADMUXBUS)

- (16) For 133 MHz:

- CTRLMMR\_GPMC\_CLKSEL[1-0] CLK\_SEL = 00 = MAIN\_PLL0\_HSDIV3\_CLKOUT

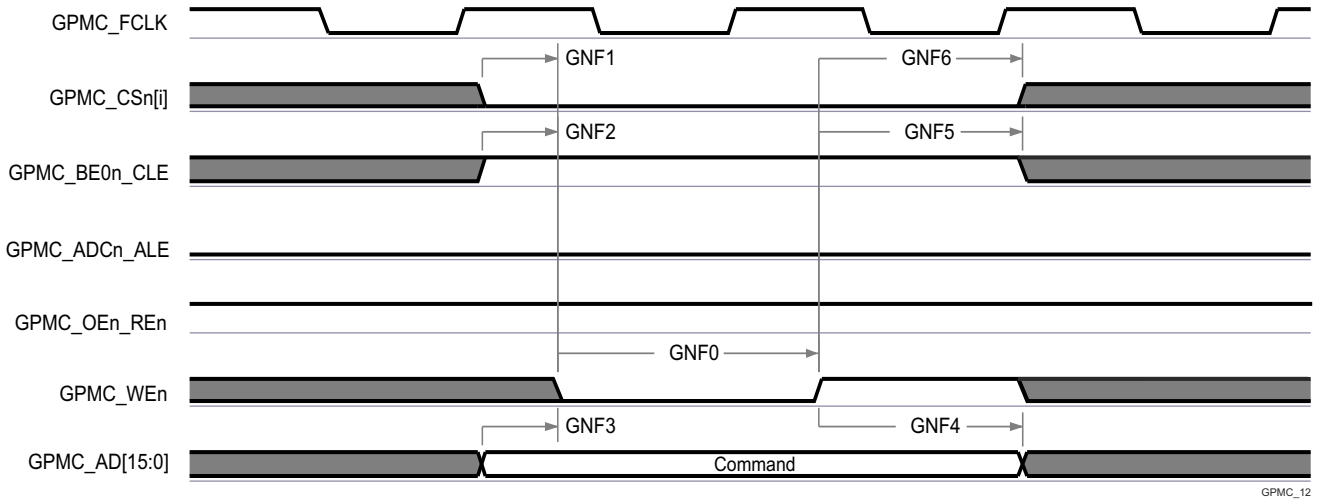

GPMC\_12

- A. In GPMC\_CS[n][i], i is equal to 0, 1, 2 or 3.

图 7-62. GPMC and NAND Flash — Command Latch Cycle

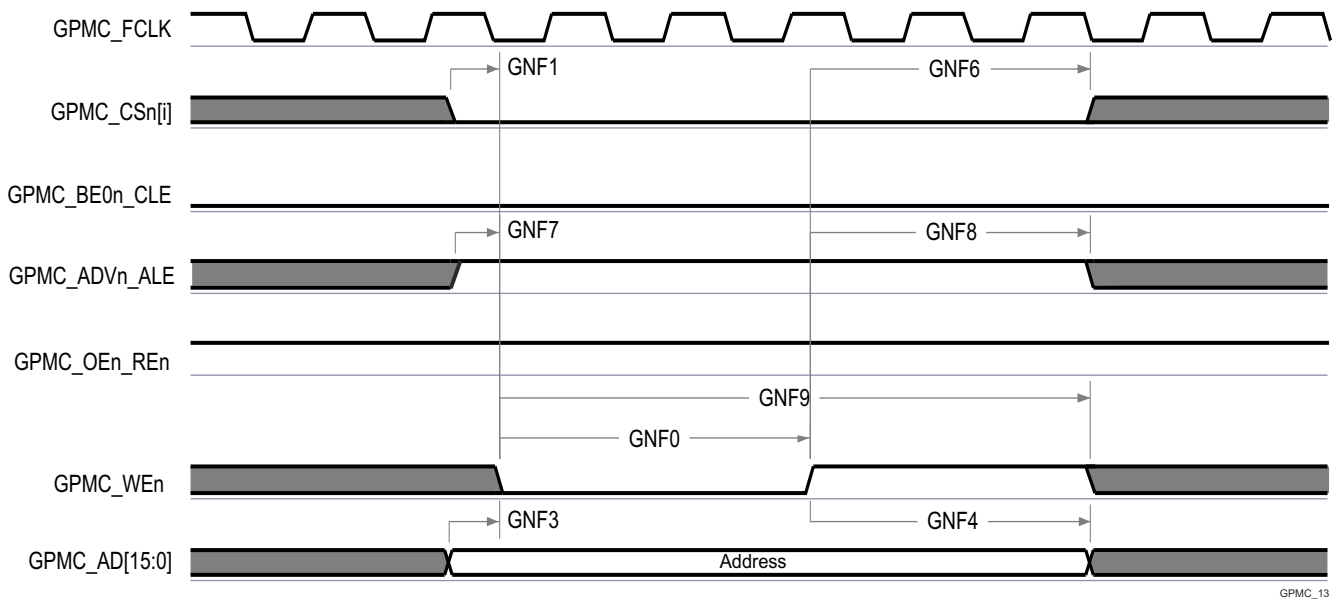

GPMC\_13

- A. In GPMC\_CS[n][i], i is equal to 0, 1, 2 or 3.

图 7-63. GPMC and NAND Flash — Address Latch Cycle

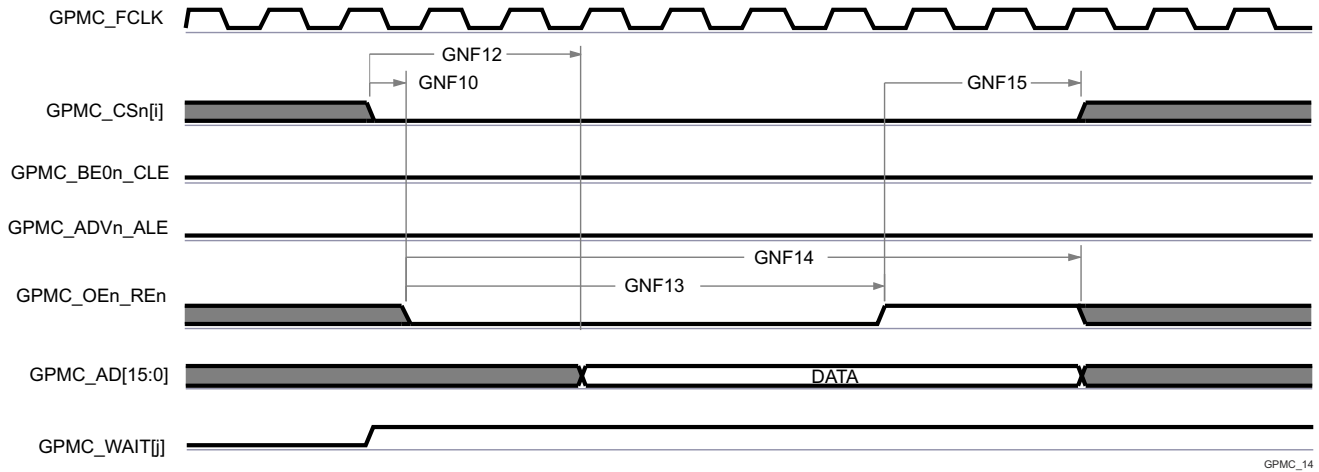

GPMC\_14

- A. GNF12 parameter illustrates amount of time required to internally sample input data. It is expressed in number of GPMC functional clock cycles. From start of read cycle and after GNF12 functional clock cycles, input data will be internally sampled by active functional clock edge. GNF12 value must be stored inside AccessTime register bits field.
- B. GPMC\_FCLK is an internal clock (GPMC functional clock) not provided externally.
- C. In GPMC\_CS[n], i is equal to 0, 1, 2 or 3. In GPMC\_WAIT[j], j is equal to 0, 1, 2, or 3.

**图 7-64. GPMC and NAND Flash — Data Read Cycle**

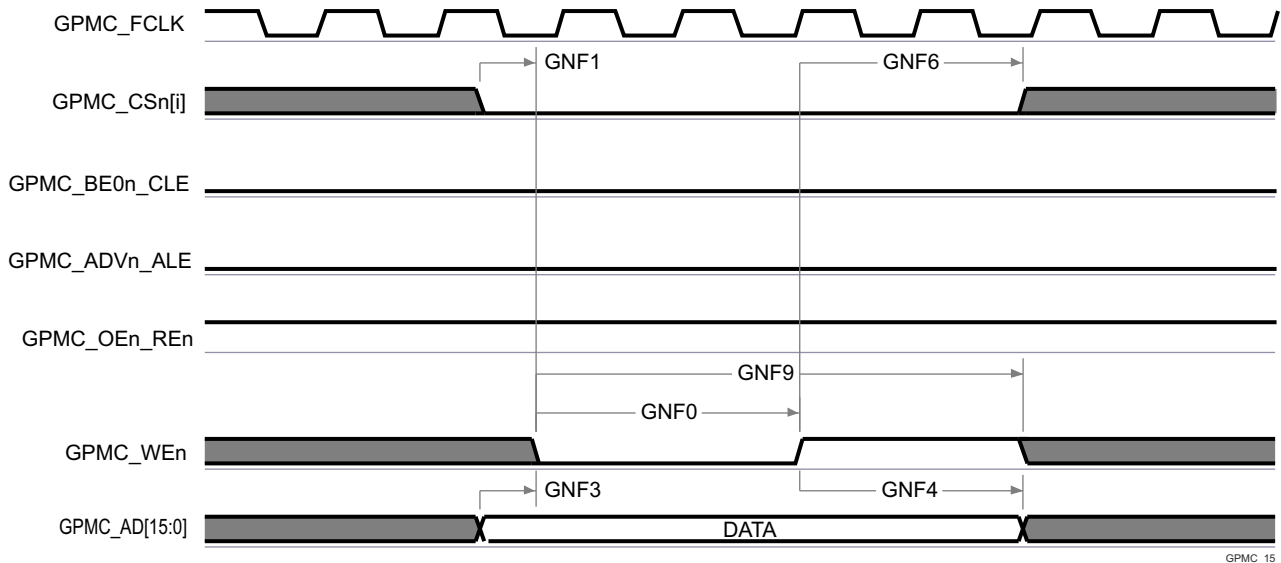

GPMC\_15

- A. In GPMC\_CS[n], i is equal to 0, 1, 2 or 3.

**图 7-65. GPMC and NAND Flash — Data Write Cycle**

For more information, see *Enhanced Pulse Width Modulation (EPWM) Module* section in *Peripherals* chapter in the device TRM.

**7.10.5.10.4 GPMC0 IOSET**

表 7-40 present the specific groupings of signals (IOSET) for use with GPMC0.

**表 7-40. GPMC0 IOSET**

Signals	IOSET1		IOSET2	
	BALL NAME	MUX	BALL NAME	MUX
GPMC0_WAIT2	MDIO0_MDC	8	MDIO0_MDC	8
GPMC0_BE1n	PRG1_PRU0_GPO0	8	RGMII6_RD1	8

**表 7-40. GPMC0 IOSET (continued)**

Signals	IOSET1		IOSET2	
	BALL NAME	MUX	BALL NAME	MUX
GPMC0_WAIT0	PRG1_PRU0_GPO1	8	PRG1_PRU0_GPO1	8
GPMC0_WAIT1	PRG1_PRU0_GPO2	8	PRG1_PRU0_GPO2	8
GPMC0_DIR	PRG1_PRU0_GPO3	8	PRG1_PRU0_GPO3	8
GPMC0_CS <sub>n</sub> 2	PRG1_PRU0_GPO4	8	PRG1_PRU0_GPO4	8
GPMC0_WEn	PRG1_PRU0_GPO5	8	PRG1_PRU0_GPO5	8
GPMC0_CS <sub>n</sub> 3	PRG1_PRU0_GPO6	8	PRG1_PRU0_GPO6	8
GPMC0_OEn_REn	PRG1_PRU0_GPO8	8	PRG1_PRU0_GPO8	8
GPMC0_ADV <sub>n</sub> _ALE	PRG1_PRU0_GPO9	8	PRG1_PRU0_GPO9	8
GPMC0_BE0 <sub>n</sub> _CLE	PRG1_PRU0_GPO10	8	PRG1_PRU0_GPO10	8
GPMC0_WP <sub>n</sub>	PRG1_PRU1_GPO5	8	PRG1_PRU1_GPO5	8
GPMC0_CS <sub>n</sub> 1	PRG1_PRU1_GPO8	8	PRG1_PRU1_GPO8	8
GPMC0_CS <sub>n</sub> 0	PRG1_PRU1_GPO9	8	PRG1_PRU1_GPO9	8
GPMC0_CLKOUT	PRG1_PRU1_GPO10	8	PRG1_PRU1_GPO10	8
GPMC0_AD0	PRG0_PRU0_GPO5	8	PRG0_PRU0_GPO5	8
GPMC0_AD1	PRG0_PRU0_GPO7	8	PRG0_PRU0_GPO7	8
GPMC0_AD2	PRG0_PRU0_GPO8	8	PRG0_PRU0_GPO8	8
GPMC0_AD3	PRG0_PRU0_GPO9	8	PRG0_PRU0_GPO9	8
GPMC0_AD4	PRG0_PRU0_GPO10	8	PRG0_PRU0_GPO10	8
GPMC0_AD5	PRG0_PRU0_GPO17	8	PRG0_PRU0_GPO17	8
GPMC0_AD6	PRG0_PRU0_GPO18	8	PRG0_PRU0_GPO18	8
GPMC0_AD7	PRG0_PRU0_GPO19	8	PRG0_PRU0_GPO19	8
GPMC0_AD8	PRG0_PRU1_GPO5	8	PRG0_PRU1_GPO5	8
GPMC0_AD9	PRG0_PRU1_GPO7	8	PRG0_PRU1_GPO7	8
GPMC0_AD10	PRG0_PRU1_GPO8	8	PRG0_PRU1_GPO8	8
GPMC0_AD11	PRG0_PRU1_GPO9	8	PRG0_PRU1_GPO9	8
GPMC0_AD12	PRG0_PRU1_GPO10	8	PRG0_PRU1_GPO10	8
GPMC0_AD13	PRG0_PRU1_GPO17	8	PRG0_PRU1_GPO17	8
GPMC0_AD14	PRG0_PRU1_GPO18	8	PRG0_PRU1_GPO18	8
GPMC0_AD15	PRG0_PRU1_GPO19	8	PRG0_PRU1_GPO19	8
GPMC0_A0	PRG0_MDIO0_MDC	8	PRG0_MDIO0_MDC	8
GPMC0_A1	RGMII5_TX_CTL	8	RGMII5_TX_CTL	8
GPMC0_A2	RGMII5_RX_CTL	8	RGMII5_RX_CTL	8
GPMC0_A3	RGMII5_TD3	8	RGMII5_TD3	8
GPMC0_A4	RGMII5_TD2	8	RGMII5_TD2	8
GPMC0_A5	RGMII5_TD1	8	RGMII5_TD1	8
GPMC0_A6	RGMII5_TD0	8	RGMII5_TD0	8
GPMC0_A7	RGMII5_TXC	8	RGMII5_TXC	8
GPMC0_A8	RGMII5_RXC	8	RGMII5_RXC	8
GPMC0_A9	RGMII5_RD3	8	RGMII5_RD3	8
GPMC0_A10	RGMII5_RD2	8	RGMII5_RD2	8
GPMC0_A11	RGMII5_RD1	8	RGMII5_RD1	8
GPMC0_A12	RGMII5_RD0	8	RGMII5_RD0	8
GPMC0_A13	RGMII6_TX_CTL	8	RGMII6_TX_CTL	8
GPMC0_A14	RGMII6_RX_CTL	8	RGMII6_RX_CTL	8

表 7-40. GPMC0 IOSET (continued)

Signals	IOSET1		IOSET2	
	BALL NAME	MUX	BALL NAME	MUX
GPMC0_A15	RGMII6_TD3	8	RGMII6_TD3	8
GPMC0_A16	RGMII6_TD2	8	RGMII6_TD2	8
GPMC0_A17	RGMII6_TD1	8	RGMII6_TD1	8
GPMC0_A18	RGMII6_TD0	8	RGMII6_TD0	8
GPMC0_A19	RGMII6_TXC	8	RGMII6_TXC	8
GPMC0_A20	RGMII6_RXC	8	RGMII6_RXC	8
GPMC0_A21	RGMII6_RD3	8	RGMII6_RD3	8
GPMC0_A22	RGMII6_RD2	8	RGMII6_RD2	8
GPMC0_A23	PRG0_PRU1_GPO2	8	PRG0_PRU1_GPO2	8
GPMC0_A24	PRG0_PRU1_GPO4	8	PRG0_PRU1_GPO4	8
GPMC0_A25	PRG0_PRU1_GPO6	8	PRG0_PRU1_GPO6	8
GPMC0_A26	PRG0_PRU1_GPO11	8	PRG0_PRU1_GPO11	8
GPMC0_A27	PRG0_MDIO0_MDIO	8	PRG0_MDIO0_MDIO	8
GPMC0_WAIT3	MDIO0_MDIO	8	MDIO0_MDIO	8

### 7.10.5.11 HyperBus

For more details about features and additional description information on the device HyperBus, see the corresponding sections within [Signal Descriptions](#) and [Detailed Description](#).

节 7.10.5.11, 节 7.10.5.11.2, 和 节 7.10.5.11.3 assume testing over the recommended operating conditions and electrical characteristic conditions (see 图 7-66, 图 7-67, 和 图 7-68).

表 7-41 represents HyperBus timing conditions.

表 7-41. HyperBus Timing Conditions

PARAMETER	DESCRIPTION	MIN	MAX	UNIT
<b>INPUT CONDITIONS</b>				
SR <sub>i</sub>	Input slew rate	2	5	V/ns
<b>OUTPUT CONDITIONS</b>				
C <sub>L</sub>	Output load capacitance			

#### 7.10.5.11.1 Timing Requirements for HyperBus

NO.	PARAMETER	DESCRIPTION	MIN	MAX	UNIT
D1	t <sub>w</sub> (RESETn)	Pulse width, RESETn	200		ns
D2	t <sub>w</sub> (csL)	Pulse width, Chip Select	1000		ns
D3	t <sub>d</sub> (RESETnH-csL)	Delay time, RESETn inactive to CSn active	200.34		ns
D4	t <sub>d</sub> (csL-RWDSL)	Delay time, CSn active to RWDS falling	115		ns

#### 7.10.5.11.2 HyperBus 166 MHz Switching Characteristics

NO.	PARAMETER	DESCRIPTION	MIN	MAX	UNIT
D5	t <sub>skn</sub> (rwdsX-dV)	Input skew, RWDS transitioning to D0:D7 valid	-0.46	0.46	ns
D6	t <sub>c</sub> (clk/clkn)	CLK period, CLK/CLKn	6		ns
D7	t <sub>w</sub> (clk/clkn)	Pulse width, CLK/CLKn	2.7		ns
D8	t <sub>w</sub> (csIV)	Pulse width, CS0 invalid between operations	6		ns
D9	t <sub>d</sub> (clkH-csL)	Delay time, CS0 active to CLK rising/ CLKn falling		-3.34	ns
D10	t <sub>d</sub> (clkL[LE]-csH)	Delay time, last falling CLK/ rising CLKn edge to CS0 inactive	0.41		ns

NO.	PARAMETER	DESCRIPTION	MIN	MAX	UNIT
D11	$t_{d(\text{clkX-rwdsV})}$	Delay time, CLK transition to RWDS valid	1.01	2.08	ns
D12	$t_{d(\text{clkX-d}[0:7]V)}$	Delay time, CLK transitioning to D0:D7 valid	0.84	2.17	ns

### 7.10.5.11.3 HyperBus 100 MHz Switching Characteristics

NO.	PARAMETER	DESCRIPTION	MIN	MAX	UNIT
LFD5	$t_{\text{skn}(\text{rwdsX-dV})}$	Input skew, RWDS transitioning to D0:D7 valid	-0.81	0.81	ns
LFD6	$t_{c(\text{clk})}$	CLK period, CLK	10		ns
LFD7	$t_{w(\text{clk})}$	Pulse width, CLK	4.75		ns
LFD8	$t_{w(\text{csIV})}$	Pulse width, CS0 invalid between operations	10		ns
LFD9	$t_{d(\text{clkH-csL})}$	Delay time, CS0 active to CLK rising		-3.51	ns
LFD10	$t_{d(\text{clkL}[LE]-\text{csH})}$	Delay time, last falling CLK edge to CS0 inactive	0.51		ns
LFD11	$t_{d(\text{clkX-rwdsV})}$	Delay time, CLK transition to RWDS valid	1.51	3.49	ns
LFD12	$t_{d(\text{clkX-d}[0:7]V)}$	Delay time, CLK transitioning to D0:D7 valid	1.34	3.66	ns

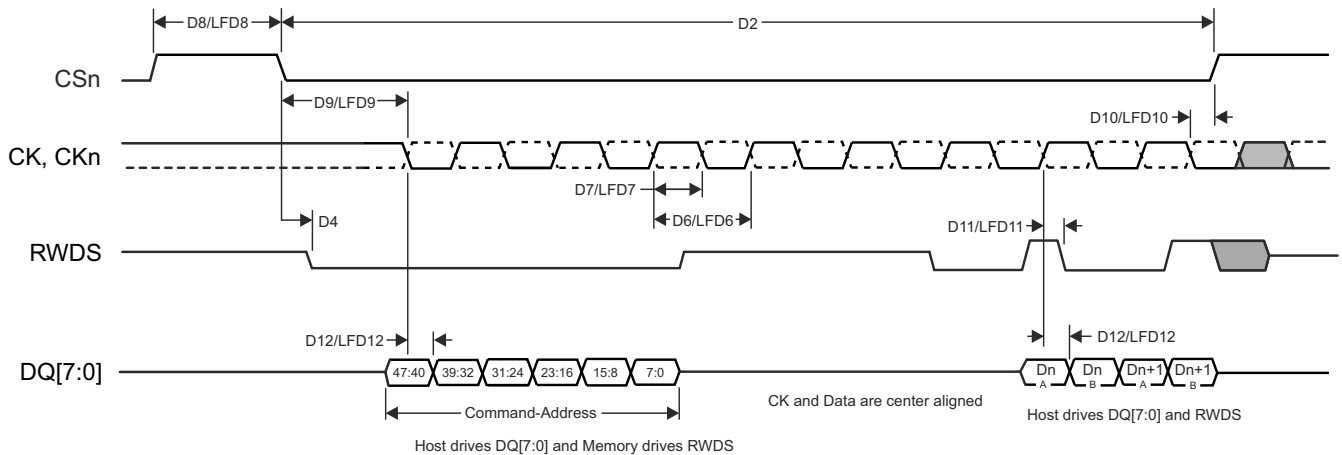

HYPERBUS\_TIMING\_01

图 7-66. HyperBus Timing Diagrams - Transmitter Mode

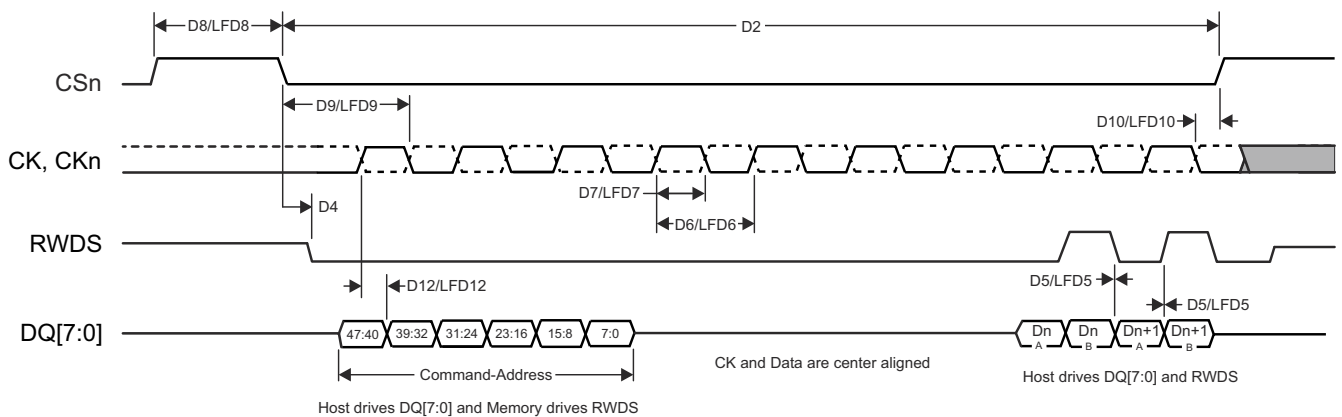

HYPERBUS\_TIMING\_02

图 7-67. HyperBus Timing Diagrams - Receiver Mode



图 7-68. HyperBus Timing Diagrams - Reset

For more information, see *HyperBus Interface* section in *Peripherals* chapter in the device TRM.

### 7.10.5.12 I2C

The device contains **several** multicontroller Inter-Integrated Circuit (I2C) controllers. Each I2C controller was designed to be compliant to the Philips I2C-bus™ specification version 2.1. However, the device **IO Buffers** are not fully compliant to the I2C electrical specification. **Some I2C instances use the LVCMOS Buffer Type, while other instances use the I2S OD FS Buffer type. See the Pin Attributes table to determine the IO Buffer Type used for each I2C instance on this device.** The I2C speeds supported and exceptions are described per **IO Buffer Type** below:

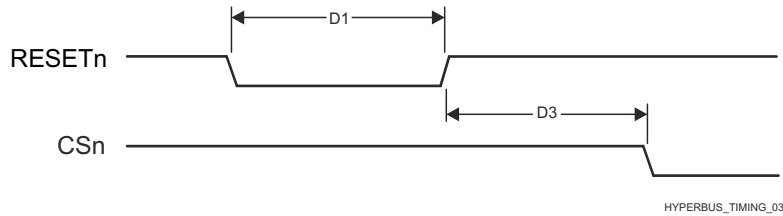
- I2C instances that use the LVCMOS buffer type
  - Speeds:
    - Standard-mode (up to 100 Kbits/s)
      - 1.8 V
      - 3.3 V
    - Fast-mode (up to 400 Kbits/s)
      - 1.8 V
      - 3.3 V
  - Exceptions:
    - The IOs associated with these ports are not compliant to the fall time requirements defined in the I2C specification because they are implemented with higher performance LVCMOS push-pull IOs that were designed to support other signal functions that could not be implemented with I2C compatible IOs. The LVCMOS IOs being used on these ports are connected such they emulate open-drain outputs. This emulation is achieved by forcing a constant low output and disabling the output buffer to enter the Hi-Z state.
    - The I2C specification defines a maximum input voltage  $V_{IH}$  of  $(V_{DD_{max}} + 0.5 V)$ , which exceeds the absolute maximum ratings for the device IOs. The system must be designed to ensure the I2C signals never exceed the limits defined in the [Absolute Maximum Ratings](#) section of this data sheet.
- I2C instances that use the I2C OD FS buffer type
  - Speeds:
    - Standard-mode (up to 100 Kbits/s)
      - 1.8 V
      - 3.3 V
    - Fast-mode (up to 400 Kbits/s)
      - 1.8 V
      - 3.3 V
    - Hs-mode (up to 3.4 Mbit/s)
      - 1.8 V
  - Exceptions:
    - The IOs associated with these ports were not design to support Hs-mode while operating at 3.3 V. So Hs-mode is limited to 1.8-V operation.
    - The rise and fall times of the I2C signals connected to these ports must not exceed a slew rate of 0.8 V/ns (or 8E+7 V/s). This limit is more restrictive than the minimum fall time limits defined in the I2C

specification. Therefore, it may be necessary to add additional capacitance to the I2C signals to slow the rise and fall times such that they do not exceed a slew rate of 0.8 V/ns.

- The I2C specification defines a maximum input voltage  $V_{IH}$  of  $(V_{DD_{max}} + 0.5 \text{ V})$ , which exceeds the absolute maximum ratings for the device IOs. The system must be designed to ensure the I2C signals never exceed the limits defined in the [Absolute Maximum Ratings](#) section of this data sheet.

Refer to the Philips I2C-bus specification version 2.1 for timing details.

For more details about features and additional description information on the device Inter-Integrated Circuit, see the corresponding subsections within [节 6.3](#) and *Detailed Description*.

### 7.10.5.13 I3C

For more details about features and additional description information on the device Inter-Integrated Circuit, see the corresponding sections within [Signal Descriptions](#), *Signal Descriptions* and *Detailed Description*.

表 7-42, 表 7-43, 图 7-69, 表 7-44, and 图 7-70 assume testing over the recommended operating conditions and electrical characteristic conditions.

**表 7-42. I3C Open Drain Timing Conditions**

PARAMETER		MIN	MAX	UNIT
<b>INPUT CONDITIONS</b>				
SR <sub>I</sub>	Input slew rate	0.2276	5	V/ns
<b>OUTPUT CONDITIONS</b>				
C <sub>L</sub>	Output load capacitance		50	pF

**表 7-43. I3C Open Drain Timing Parameters**

NO.	PARAMETER	DESCRIPTION	MODE	MIN	MAX	UNIT
D1	t <sub>LOW_OD</sub>	Low Period of SCL Clock	Controller	200		ns
	t <sub>DIG_OD_L</sub>			t <sub>LOW_OD MIN</sub> + t <sub>FDA_OD MIN</sub>		ns
D2	t <sub>HIGH</sub>	High Period of SCL Clock	Controller		41	ns
	t <sub>DIG_H</sub>			t <sub>HIGH</sub> + t <sub>CF</sub>		ns
D3	t <sub>rDA_OD</sub>	Fall Time of SDA Signal	Controller, Target	t <sub>CF</sub>	12	ns
D4	t <sub>SU_OD</sub>	SDA Data Setup Time During Open Drain Mode	Controller, Target	3		ns
D5	t <sub>CAS</sub>	Clock After START (S) Condition	Controller, ENTAS0	38.4	1000	ns
			Controller, ENTAS1	38.4	100000	ns
			Controller, ENTAS2	38.4	2000000	ns
			Controller, ENTAS3	38.4	5000000	ns
D6	t <sub>CBP</sub>	Clock Before STOP (P) Condition	Controller	t <sub>CAS MIN</sub> / 2		ns
D7	t <sub>MMOVERLAP</sub>	Current Controller to Secondary Controller Overlap time during handoff	Controller	t <sub>DIG_OD_L min</sub>		ns
D8	t <sub>AVAIL</sub>	Bus Available Condition	Controller	1000		ns
D9	t <sub>IDLE</sub>	Bus Idle Condition	Controller	1000000		ns
D10	t <sub>MMLOCK</sub>	Time Interval Where New Controller Not Driving SDA Low	Controller	t <sub>AVAIL min</sub>		ns

1. This is approximately equal to  $t_{LOW_{min}} + t_{DS\_OD_{min}} + t_{rDA\_OD_{typ}} + t_{SU\_OD_{min}}$ .

- The Controller may use a shorter Low period if the Controller knows that this is safe, when SDA is already above  $V_{IH}$ .
- Based on  $t_{SPIKE}$ , rise and fall times, and interconnect.
- This maximum High period may be exceeded when the signals can be safely seen by Legacy I2C Devices, and/or in consideration of the interconnect (for example: a short Bus).
- On a Legacy Bus where I2C Devices need to see Start, the  $t_{CAS}$  Min value is further constrained.
- Targets that do not support the optional ENTASx CCCs shall use the  $t_{CAS}$  Max value shown for ENTAS3.
- On a Mixed Bus with Fm Legacy I2C Devices,  $t_{AVAIL}$  is 300ns shorter than the Fm Bus Free Condition time ( $t_{BUF}$ ).

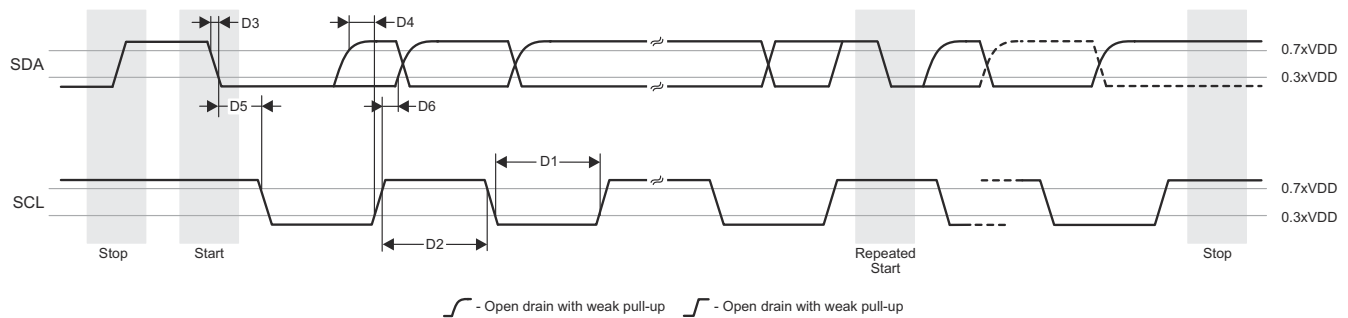

I3C\_TIMING\_01

**图 7-69. I3C Open Drain Timing**
**表 7-44. I3C Push-Pull Timing Parameters for SDR and HDR-DDR Modes**

NO.	PARAMETER	DESCRIPTION	MODE	MIN	MAX	UNIT
D1	$f_{SCL}$	SCL Clock Period	Controller	80	100000	ns
D2	$t_{LOW}$	SCL Clock Low Period	Controller	24		ns
	$t_{DIG\_L}$			32		ns
D3	$t_{HIGH\_MIXED}$	SCL Clock High Period of Mixed Bus (Mixed Bus Topology Not Supported)	Controller	24		ns
	$t_{DIG\_H\_MIXED}$			32	45	ns
D4	$t_{HIGH}$	SCL Clock High Period	Controller	24		ns
	$t_{DIG\_H}$			32		ns
D5	$t_{SCO}$	Clock in to Data Out for Target	Target	12		ns
D6	$t_{CR}$	SCL Clock Rise Time	Controller	$150 \times 1 / f_{SCL}$	60	ns
D7	$t_{CF}$	SCL Clock Fall Time	Controller	$150 \times 1 / f_{SCL}$	60	ns
D8	$t_{HD\_PP}$	SDA Signal Data Hold in Push Pull Mode	Controller	$t_{CR} + 3$ and $t_{CF} + 3$		ns
			Target	0		ns
D9	$t_{SU\_PP}$	SDA Signal Data Setup In Push-Pull Mode	Controller, Target	3		ns
D10	$t_{CASr}$	Clock After Repeated START (Sr)	Controller	$t_{CAS}$ MIN		ns
D11	$t_{CBSr}$	Clock Before Repeated START (Sr)	Controller	$t_{CAS}$ MIN / 2		ns

- $f_{SCL} = 1 / (t_{DIG\_L} + t_{DIG\_H})$
- $t_{DIG\_L}$  and  $t_{DIG\_H}$  are the clock Low and High periods as seen at the receiver end of the I3C Bus using  $V_{IL}$  and  $V_{IH}$ .
- When communicating with an I3C Device on a mixed Bus, the  $t_{DIG\_H\_MIXED}$  period must be constrained to make sure that I2C Devices do not interpret I3C signaling as valid I2C signaling.
- As both edges are used, the hold time needs to be satisfied for the respective edges;  $t_{CF} + 3$  for falling edge clocks, and  $t_{CR} + 3$  for rising edge clocks.

5. Clock Frequency Minimum 0.01 MHz, Maximum 12.5 MHz



图 7-70. I3C Push-Pull Timing (SDR and HDR-DDR Modes)

7.10.5.14 MCAN

For more details about features and additional description information on the device Controller Area Network Interface, see the corresponding sections within [Signal Descriptions](#) and *Detailed Description*.

备注

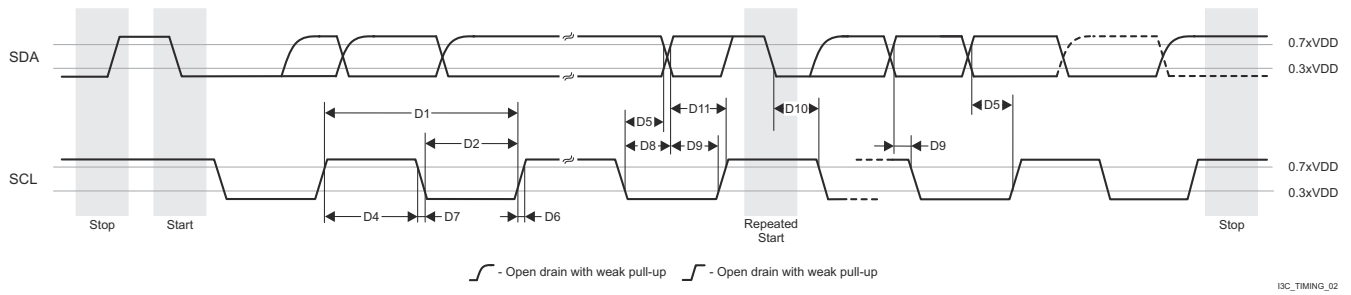
The device has multiple MCAN modules. MCANn is a generic prefix applied to MCAN signal names, where n represents the specific MCAN module.

表 7-45. MCAN Timing Conditions

PARAMETER		MIN	MAX	UNIT
<b>INPUT CONDITIONS</b>				
SR <sub>I</sub>	Input slew rate	2	15	V/ns
<b>OUTPUT CONDITIONS</b>				
C <sub>L</sub>	Output load capacitance	5	20	pF

表 7-46. MCAN Switching Characteristics

NO.	PARAMETER		MIN	MAX	UNIT
MCAN1	t <sub>d</sub> (MCAN_TX)	Delay time, transmit shift register to MCANn_TX pin <sup>(1)</sup>		10	ns
MCAN2	t <sub>d</sub> (MCAN_RX)	Delay time, MCANn_RX pin to receive shift register <sup>(1)</sup>		10	ns

(1) n is [0:13] in MCANn\_\* or [0:1] in MCU\_MCANn\_\*

For more information, see *Controller Area Network (MCAN)* section in *Peripherals* chapter in the device TRM.

### 7.10.5.15 MCASP

For more details about features and additional description information on the device Multichannel Audio Serial Port, see the corresponding sections within [Signal Descriptions](#) and [Detailed Description](#).

表 7-48 和 图 7-71 呈现 timing requirements for MCASP0 to MCASP11.

表 7-47 代表 MCASP timing conditions.

表 7-47. MCASP Timing Conditions

PARAMETER		MIN	MAX	UNIT
<b>INPUT CONDITIONS</b>				
SR <sub>I</sub>	Input slew rate	0.7	5	V/ns
<b>OUTPUT CONDITIONS</b>				
C <sub>L</sub>	Output load capacitance	1	10	pF
<b>PCB CONNECTIVITY REQUIREMENTS</b>				
t <sub>d</sub> (Trace Delay)	Propagation delay of each trace	100	1100	ps
t <sub>d</sub> (Trace Mismatch Delay)	Propagation delay mismatch across all traces		100	ps

表 7-48. MCASP Timing Requirements

NO.			MODE <sup>(1)</sup>	MIN	MAX	UNIT
ASP1	t <sub>c</sub> (AHCLKRX)	Cycle time, MCASP[x]_AHCLKR/X		15.26		ns
ASP2	t <sub>w</sub> (AHCLKRX)	Pulse duration, MCASP[x]_AHCLKR/X high or low		0.5P <sup>(2)</sup> - 1.53		ns
ASP3	t <sub>c</sub> (ACLKRX)	Cycle time, MCASP[x]_ACLKR/X		15.26		ns
ASP4	t <sub>w</sub> (ACLKRX)	Pulse duration, MCASP[x]_ACLKR/X high or low		0.5R <sup>(3)</sup> - 1.53		ns
ASP5	t <sub>su</sub> (AFSRX-ACLKRX)	Setup time, MCASP[x]_AFSR/X input valid before MCASP[x]_ACLKR/X	ACLKR/X int	12.3		ns
			ACLKR/X ext in/out	4		
ASP6	t <sub>h</sub> (ACLKRX-AFSRX)	Hold time, MCASP[x]_AFSR/X input valid after MCASP[x]_ACLKR/X	ACLKR/X int	- 1		ns
			ACLKR/X ext in/out	1.6		
ASP7	t <sub>su</sub> (AXR-ACLKRX)	Setup time, MCASP[x]_AXR input valid before MCASP[x]_ACLKR/X	ACLKR/X int	12.3		ns
			ACLKR/X ext in/out	4		
ASP8	t <sub>h</sub> (ACLKRX-AXR)	Hold time, MCASP[x]_AXR input valid after MCASP[x]_ACLKR/X	ACLKR/X int	-1		ns
			ACLKR/X ext in/out	1.6		

- (1) ACLKR internal: ACLKRCTL.CLKRM=1, PDIR.ACLKR = 1  
 ACLKR external input: ACLKRCTL.CLKRM=0, PDIR.ACLKR=0  
 ACLKR external output: ACLKRCTL.CLKRM=0, PDIR.ACLKR=1  
 ACLKX internal: ACLKXCTL.CLKXM=1, PDIR.ACLKX = 1  
 ACLKX external input: ACLKXCTL.CLKXM=0, PDIR.ACLKX=0  
 ACLKX external output: ACLKXCTL.CLKXM=0, PDIR.ACLKX=1
- (2) P = AHCLKR/X period in ns.
- (3) R = ACLKR/X period in ns.

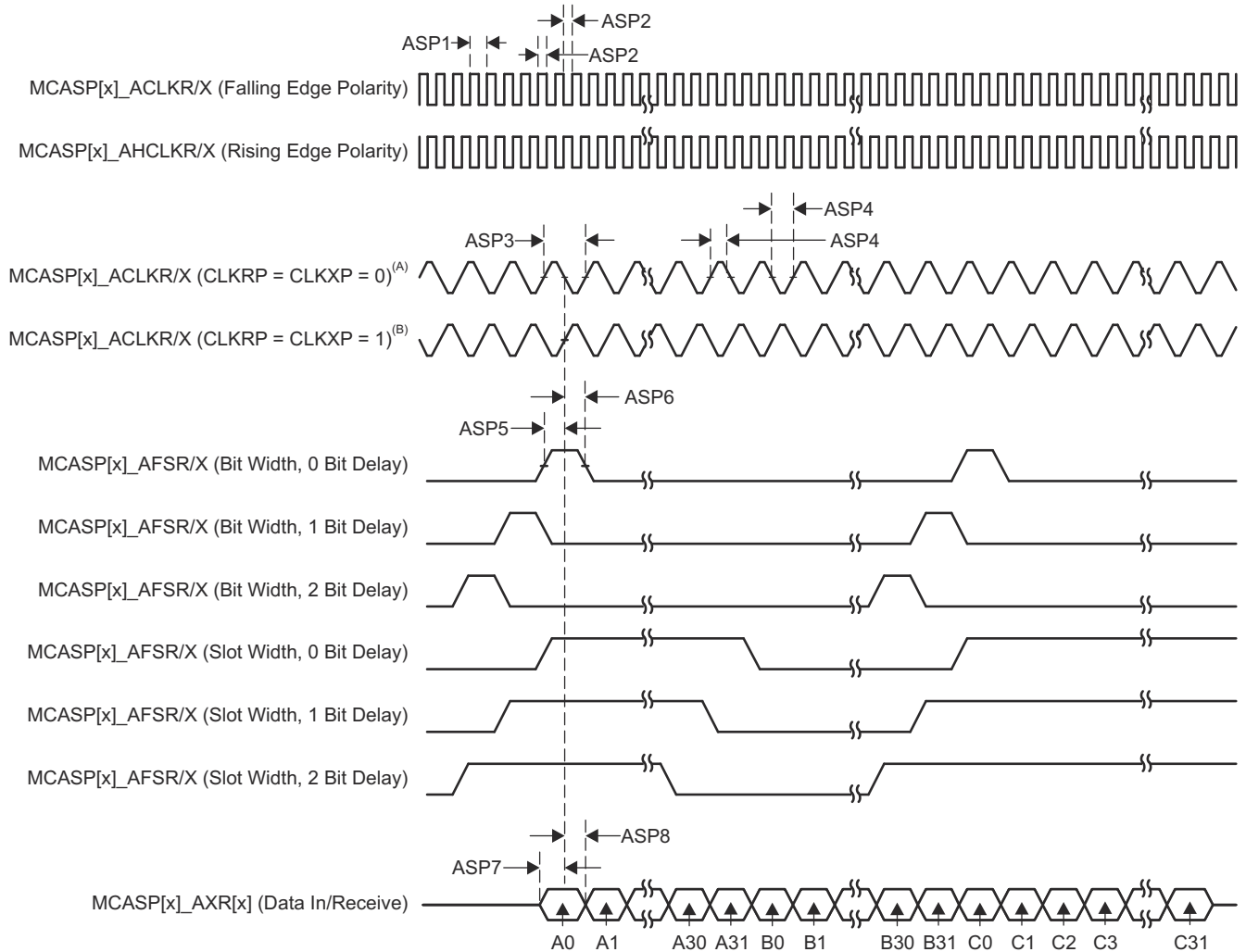

- A. For CLKRP = CLKXP = 0, the MCASP transmitter is configured for rising edge (to shift data out) and the MCASP receiver is configured for falling edge (to shift data in).
- B. For CLKRP = CLKXP = 1, the MCASP transmitter is configured for falling edge (to shift data out) and the MCASP receiver is configured for rising edge (to shift data in).

图 7-71. MCASP Input Timing

表 7-49 和 图 7-72 present switching characteristics over recommended operating conditions for MCASP0 to MCASP11.

**表 7-49. MCASP Switching Characteristics**

NO.	PARAMETER	DESCRIPTION	MODE <sup>(1)</sup>	MIN	MAX	UNIT
ASP9	$t_c(\text{AHCLKRX})$	Cycle time, MCASP[x]_AHCLKR/X		20		ns
ASP10	$t_w(\text{AHCLKRX})$	Pulse duration, MCASP[x]_AHCLKR/X high or low		0.5P <sup>(2)</sup> - 2		ns
ASP11	$t_c(\text{ACLKRX})$	Cycle time, MCASP[x]_ACLKRX		20		ns
ASP12	$t_w(\text{ACLKRX})$	Pulse duration, MCASP[x]_ACLKRX high or low		0.5R <sup>(3)</sup> - 2		ns
ASP13	$t_d(\text{ACLKRX-AFSRX})$	Delay time, MCASP[x]_ACLKRX transmit edge to MCASP[x]_AFSRX output valid	ACLKRX int	0	7.25	ns
			ACLKRX ext in/out	- 15.28	12.84	
ASP14	$t_d(\text{ACLKX-AXR})$	Delay time, MCASP[x]_ACLKX transmit edge to MCASP[x]_AXR output valid	ACLKRX int	0	7.25	ns
			ACLKRX ext in/out	- 15.28	12.84	
ASP15	$t_{dis}(\text{ACLKX-AXR})$	Disable time, MCASP[x]_ACLKX transmit edge to MCASP[x]_AXR output high impedance	ACLKRX int	0	7.25	ns
			ACLKRX ext in/out	- 14.9	14	

- (1) ACLKR internal: ACLKRCTL.CLKRM=1, PDIR.ACLKR = 1  
 ACLKR external input: ACLKRCTL.CLKRM=0, PDIR.ACLKR=0  
 ACLKR external output: ACLKRCTL.CLKRM=0, PDIR.ACLKR=1  
 ACLKX internal: ACLKXCTL.CLKXM=1, PDIR.ACLKX = 1  
 ACLKX external input: ACLKXCTL.CLKXM=0, PDIR.ACLKX=0  
 ACLKX external output: ACLKXCTL.CLKXM=0, PDIR.ACLKX=1
- (2) P = AHCLKR/X period in ns.
- (3) R = ACLKR/X period in ns.

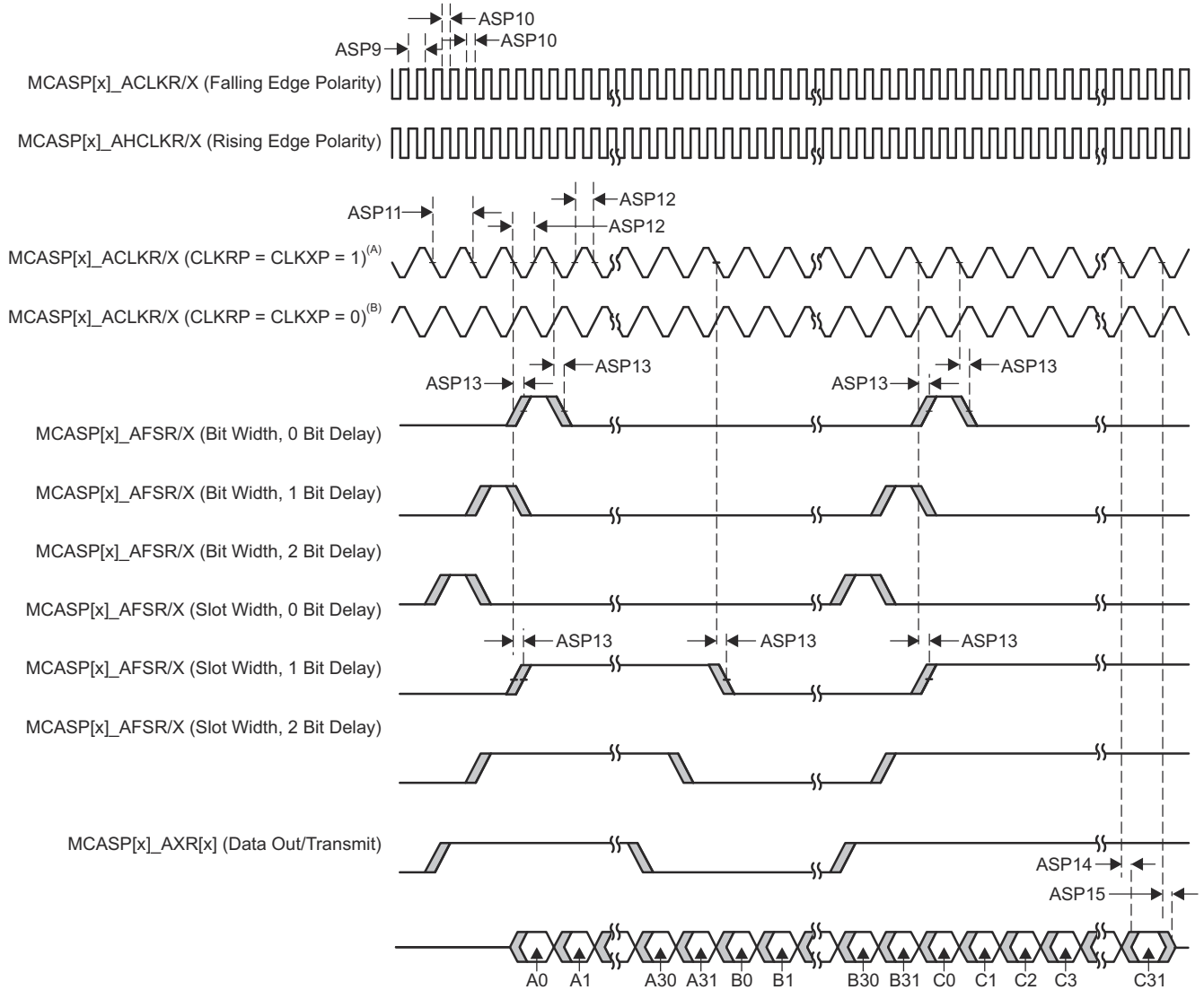

- For  $CLKRP = CLKXP = 1$ , the MCASP transmitter is configured for falling edge (to shift data out) and the MCASP receiver is configured for rising edge (to shift data in).
- For  $CLKRP = CLKXP = 0$ , the MCASP transmitter is configured for rising edge (to shift data out) and the MCASP receiver is configured for falling edge (to shift data in).

图 7-72. MCASP Output Timing

For more information, see *Multichannel Audio Serial Port (MCASP)* section in *Peripherals* chapter in the device TRM.

### 7.10.5.16 MCSPI

For more details about features and additional description information on the device Serial Port Interface, see the corresponding sections within [Signal Descriptions](#) and *Detailed Description*.

For more information, see *Multichannel Serial Peripheral Interface (MCSPI)* section in *Peripherals* chapter in the device TRM.

表 7-50 represents MCSPI timing conditions.

#### 备注

The IO timings provided in this section are applicable for all combinations of signals for MCU\_SPI0 and MCU\_SPI1. However, the timings are only valid for MCU\_SPI0 and MCU\_SPI1 if signals within a single IOSET are used. The IOSETs are defined in the 表 7-55 and 表 7-56 tables.

表 7-50. MCSPI Timing Conditions

PARAMETER		MIN	MAX	UNIT	
<b>INPUT CONDITIONS</b>					
SR <sub>I</sub>	Input slew rate	2	8.5	V/ns	
<b>OUTPUT CONDITIONS</b>					
C <sub>L</sub>	Output load capacitance	CLK	6	24	pF
		D[x], CSi	6	12	pF

#### 7.10.5.16.1 MCSPI — Controller Mode

表 7-51, 图 7-73, 表 7-52, and 图 7-74 present timing requirements and switching characteristics for MCSPI - Controller Mode.

表 7-51. MCSPI Timing Requirements - Controller Mode

see 图 7-73

NO.		MIN	MAX	UNIT
SM4	t <sub>su(misoV-spicklV)</sub> Setup time, SPI_D[x] valid before SPI_CLK active edge	2.9		ns
SM5	t <sub>h(spicklV-misoV)</sub> Hold time, SPI_D[x] valid after SPI_CLK active edge	2		ns

表 7-52. MCSPI Switching Characteristics - Controller Mode

see 图 7-74

NO.	PARAMETER	MODE	MIN	MAX	UNIT
SM1	t <sub>c(spiclK)</sub> Cycle time, SPI_CLK		20.8		ns
SM2	t <sub>w(spiclKL)</sub> Pulse duration, SPI_CLK low		0.5P - 1 <sup>(1)</sup>		ns
SM3	t <sub>w(spiclKH)</sub> Pulse duration, SPI_CLK high		0.5P - 1 <sup>(1)</sup>		ns
SM6	t <sub>d(spicklV-simoV)</sub> Delay time, SPI_CLK active edge to SPI_D[x] transition		-2	2	ns
SM7	t <sub>d(csV-simoV)</sub> Delay time, SPI_CSi active edge to SPI_D[x] transition		5		ns
SM8	t <sub>d(csV-spiclK)</sub> Delay time, SPI_CSi active to SPI_CLK first edge	PHA = 0 <sup>(2)</sup>	B - 4 <sup>(3)</sup>		ns
		PHA = 1 <sup>(2)</sup>	A - 4 <sup>(4)</sup>		ns
SM9	t <sub>d(spicklV-csV)</sub> Delay time, SPI_CLK last edge to SPI_CSi inactive	PHA = 0 <sup>(2)</sup>	A - 4 <sup>(4)</sup>		ns
		PHA = 1 <sup>(2)</sup>	B - 4 <sup>(3)</sup>		ns

(1) P = SPI\_CLK period in ns

(2) SPI\_CLK phase is programmable with the PHA bit of the MCSPI\_CHCONF\_0/1/2/3 register

- (3)  $B = (TCS + .5) * TSPICKREF$ , where TCSns a bit field of the MCSPI\_CHCONF\_0/1/2/3 register and Fratio = Even  $\geq 2$ .
- (4) When  $P = 20.8 \text{ ns}$ ,  $A = (TCS + 1) * TSPICKREF$ , where TCSns a bit field of the MCSPI\_CHCONF\_0/1/2/3 register.  
 When  $P > 20.8 \text{ ns}$ ,  $A = (TCS + 0.5) * Fratio * TSPICKREF$ , where TCSns a bit field of the MCSPI\_CHCONF\_0/1/2/3 register.

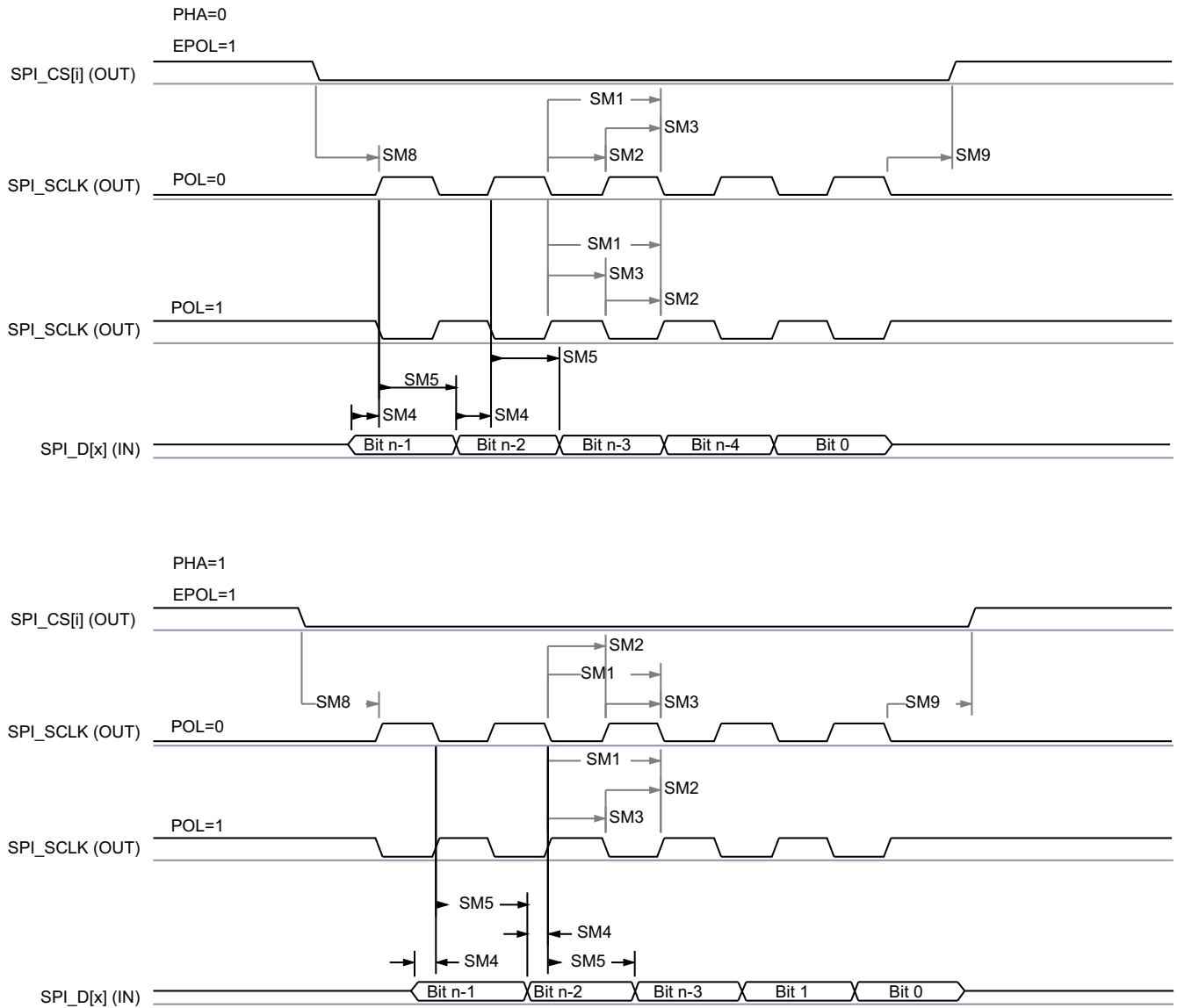

SPRSP08\_TIMING\_McSPI\_02

**图 7-73. SPI Controller Mode Receive Timing**

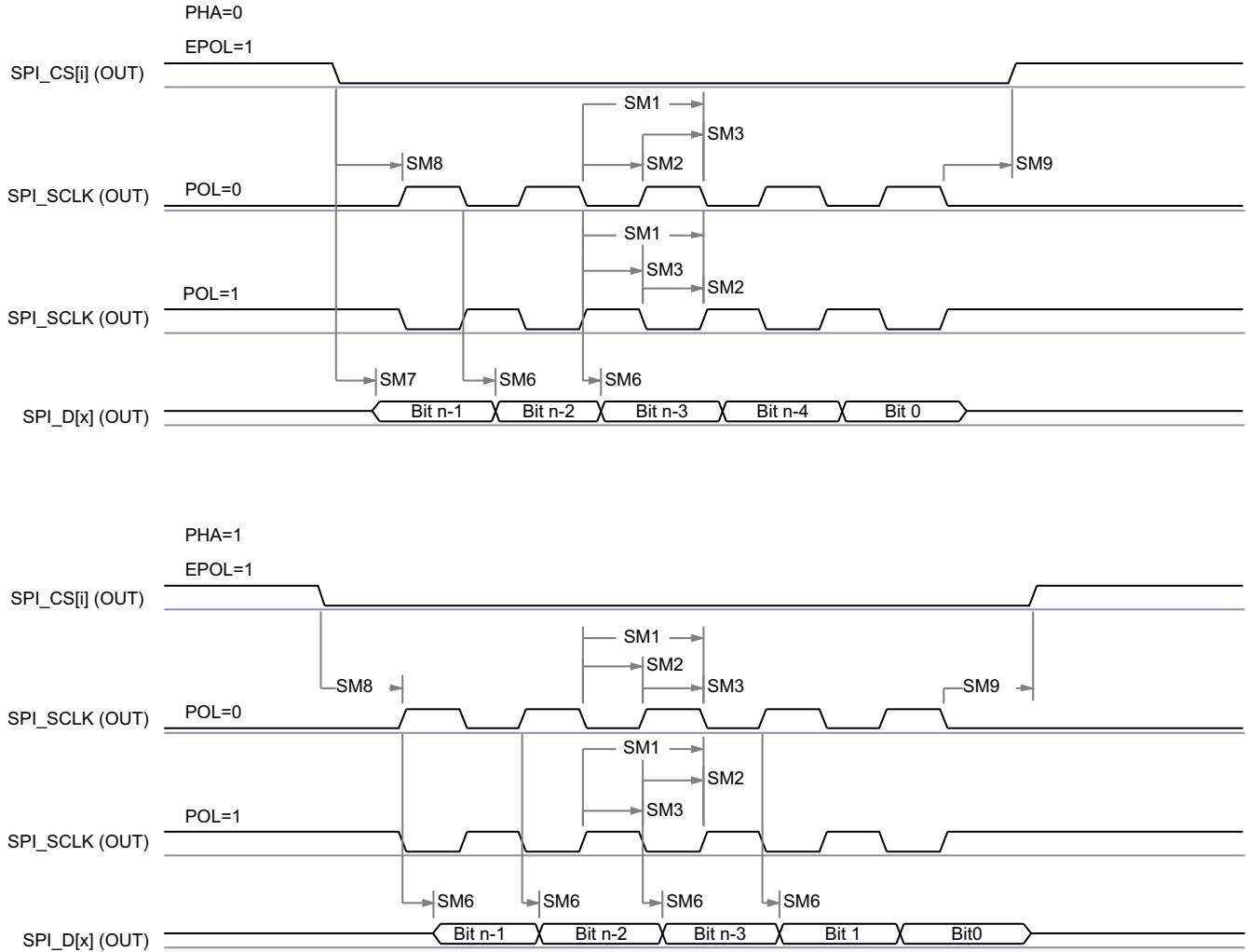

SPRSP08\_TIMING\_McSPI\_01

图 7-74. MCSPI Controller Mode Transmit Timing

### 7.10.5.16.2 MCSPI — Peripheral Mode

表 7-53, 表 7-54, 图 7-75, and 图 7-76 present timing requirements and switching characteristics for MCSPI – Peripheral Mode.

表 7-53. MCSPI Timing Requirements - Peripheral Mode

NO.	PARAMETER	DESCRIPTION	MODE	MIN	MAX	UNIT
SS1	$t_{c(spclk)}$	Cycle time, SPI_CLK		20.8		ns
SS2	$t_{w(spclkL)}$	Pulse duration, SPI_CLK low		0.45P <sup>(1)</sup>		ns
SS3	$t_{w(spclkH)}$	Pulse duration, SPI_CLK high		0.45P <sup>(1)</sup>		ns
SS4	$t_{su(simoV-spclkV)}$	Setup time, SPI_D[x] valid before SPI_CLK active edge		5		ns
SS5	$t_{h(spclkV-simoV)}$	Hold time, SPI_D[x] valid after SPI_CLK active edge		5		ns
SS8	$t_{su(csV-spclkV)}$	Setup time, SPI_CSi valid before SPI_CLK first edge		5		ns
SS9	$t_{h(spclkV-csV)}$	Hold time, SPI_CSi valid after SPI_CLK last edge		5		ns

表 7-54. MCSPI Switching Characteristics - Peripheral Mode

NO.	PARAMETER	DESCRIPTION	MIN	MAX	UNIT
SS6	$t_{d(spiclkV-somIV)}$	Delay time, SPI_CLK active edge to SPI_D[x] transition	2	17.12	ns
SS7	$t_{sk(csV-somIV)}$	Delay time, SPI_CSi active edge to SPI_D[x] transition	20.95		ns

(1) P = SPI\_CLK period in ns.

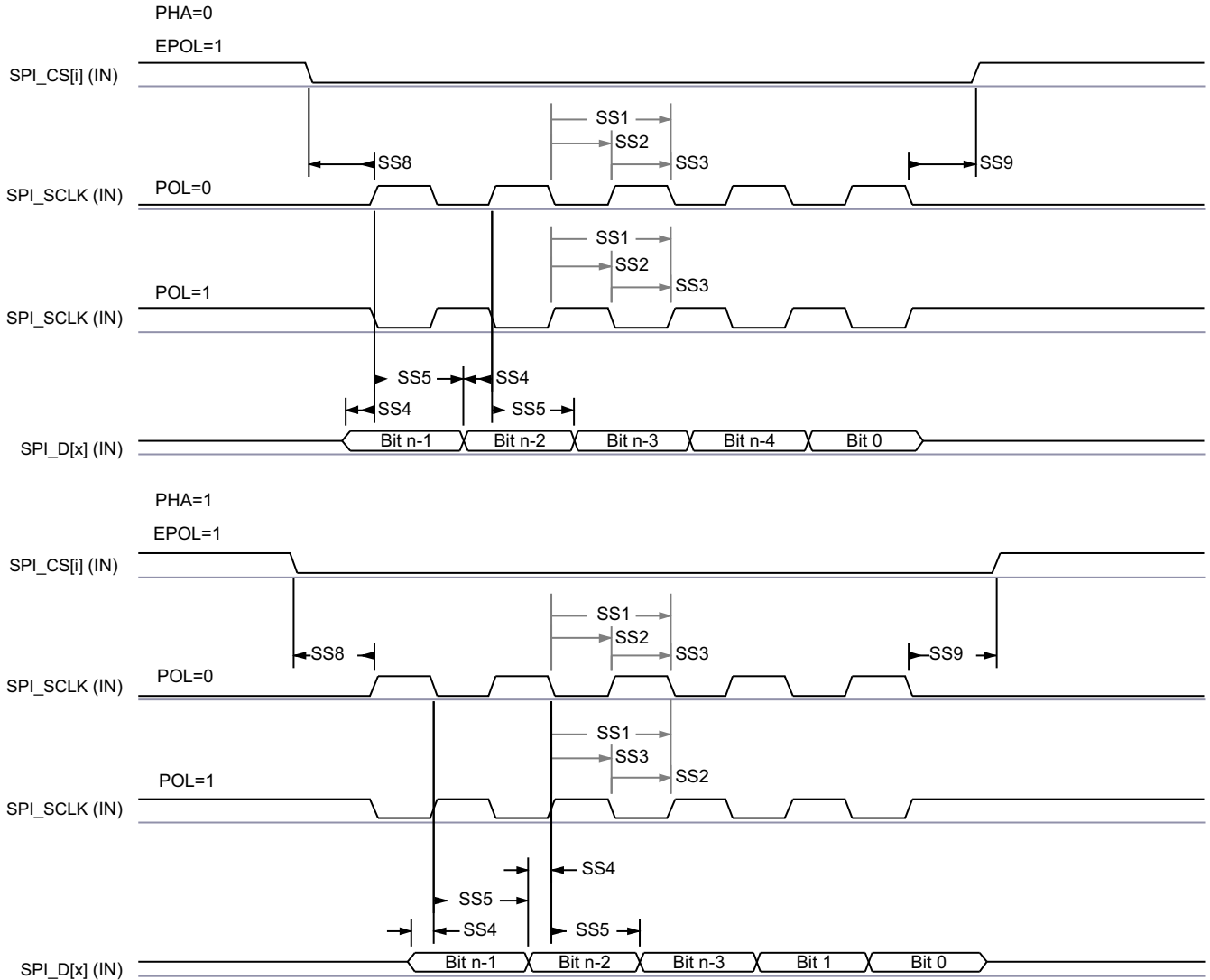

SPRSP08\_TIMING\_McSPI\_04

图 7-75. SPI Peripheral Mode Receive Timing

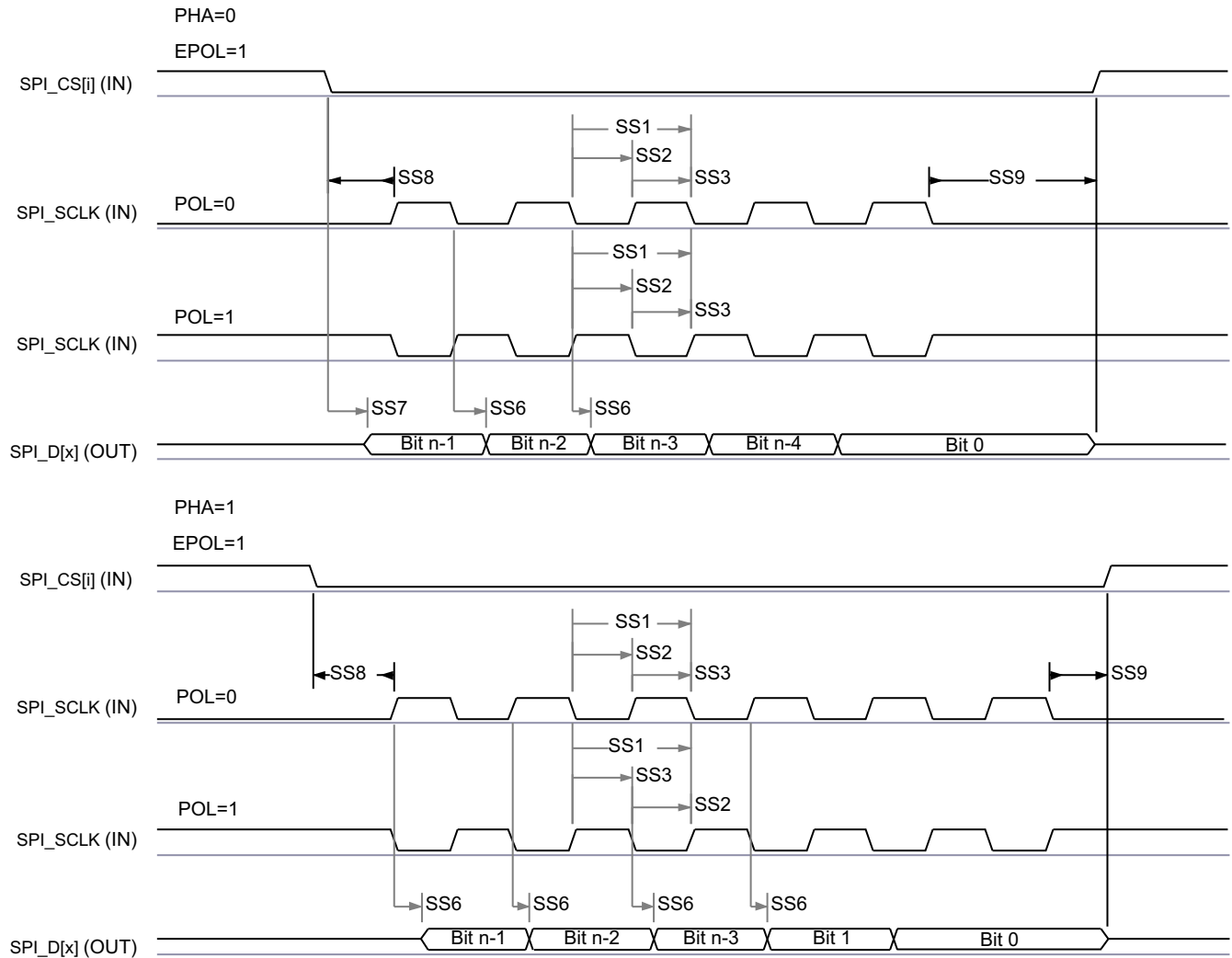

SPRSP08\_TIMING\_McSPI\_03

图 7-76. MCSPI Peripheral Mode Transmit Timing

表 7-55 和 表 7-56 present the specific groupings of signals (IOSET) for use with MCU\_SPI0 and MCU\_SPI1.

表 7-55. MCU\_SPI0 IOSETs

Signals	IOSET1		IOSET2	
	BALL NAME	MUX	BALL NAME	MUX
MCU_SPI0_CLK	MCU_SPI0_CLK	0	MCU_SPI0_CLK	0
MCU_SPI0_D0	MCU_SPI0_D0	0	MCU_SPI0_D0	0
MCU_SPI0_D1	MCU_SPI0_D1	0	MCU_SPI0_D1	0
MCU_SPI0_CS0	MCU_SPI0_CS0	0	MCU_SPI0_CS0	0
MCU_SPI0_CS1	MCU_OSPI1_D3	5	WKUP_GPIO0_12	1
MCU_SPI0_CS2	MCU_OSPI1_CSn1	5	WKUP_GPIO0_14	1

表 7-56. MCU\_SPI1 IOSET

Signals	IOSET1		IOSET2	
	BALL NAME	MUX	BALL NAME	MUX
MCU_SPI1_CLK	MCU_SPI1_CLK	0	MCU_SPI1_CLK	0
MCU_SPI1_D0	MCU_SPI1_D0	0	MCU_SPI1_D0	0
MCU_SPI1_D1	MCU_SPI1_D1	0	MCU_SPI1_D1	0
MCU_SPI1_CS0	MCU_SPI1_CS0	0	MCU_SPI1_CS0	0
MCU_SPI1_CS1	MCU_OSPI1_D1	5	WKUP_GPIO0_13	1
MCU_SPI1_CS2	MCU_OSPI1_D2	5	WKUP_GPIO0_15	1

For more information, see *Multichannel Serial Peripheral Interface (MCSPi)* section in *Peripherals* chapter in the device TRM.

### 7.10.5.17 MMCS D

The MMCS D Host Controller provides an interface to embedded Multi-Media Card (MMC), Secure Digital (SD), and Secure Digital IO (SDIO) devices. The MMCS D Host Controller deals with MMC/SD/SDIO protocol at transmission level, data packing, adding cyclic redundancy checks (CRCs), start/end bit insertion, and checking for syntactical correctness.

For more details about MMCS D interfaces, see the corresponding MMC0, MMC1, and MMC2 sections within [Signal Descriptions](#) and *Detailed Description*.

#### 备注

Some operating modes require software configuration of the MMC DLL delay settings, as shown in [表 7-57](#) 和 [表 7-67](#).

For more information, see *Multi-Media Card/Secure Digital (MMCS D) Interface* section in *Peripherals* chapter in the device TRM.

#### 7.10.5.17.1 MMC0 - eMMC Interface

MMC0 interface is compliant with the JEDEC eMMC electrical standard v5.1 (JESD84-B51) and it supports the following eMMC applications:

- Legacy speed
- High speed SDR
- High speed DDR
- High Speed HS200
- High Speed HS400

[表 7-57](#) presents the required DLL software configuration settings for MMC0 timing modes.

表 7-57. MMC0 DLL Delay Mapping for All Timing Modes

REGISTER NAME		MMCS D0_SS_PHY_CTRL_4_REG					MMCS D0_SS_PHY_CTRL_5_REG		
BIT FIELD		[31:24]	[20]	[15:12]	[8]	[4:0]	[17:16]	[10:8]	[2:0]
BIT FIELD NAME		STRBSEL	OTAPDLYENA	OTAPDLYSEL	ITAPDLYENA	ITAPDLYSEL	SELDLYTXCLK SELDLYRXCLK	FRQSEL	CLKBUFSEL
MODE	DESCRIPTION	STROBE DELAY	OUTPUT DELAY ENABLE	OUTPUT DELAY VALUE	INPUT DELAY ENABLE	INPUT DELAY VALUE	DLL/ DELAY CHAIN SELECT	DLL REF FREQUENCY	DELAY BUFFER DURATION
Legacy SDR	8-bit PHY operating 1.8 V, 25 MHz	0x0	0x0	NA	0x1	0x10	0x1	0x0	0x7
High Speed SDR	8-bit PHY operating 1.8 V, 50 MHz	0x0	0x0	NA	0x1	0xA	0x1	0x0	0x7

表 7-57. MMC0 DLL Delay Mapping for All Timing Modes (continued)

REGISTER NAME		MMCS0_SS_PHY_CTRL_4_REG					MMCS0_SS_PHY_CTRL_5_REG		
BIT FIELD		[31:24]	[20]	[15:12]	[8]	[4:0]	[17:16]	[10:8]	[2:0]
BIT FIELD NAME		STRBSEL	OTAPDLYENA	OTAPDLYSEL	ITAPDLYENA	ITAPDLYSEL	SELDLYTXCLK SELDLYRXCLK	FRQSEL	CLKBUFSEL
MODE	DESCRIPTION	STROBE DELAY	OUTPUT DELAY ENABLE	OUTPUT DELAY VALUE	INPUT DELAY ENABLE	INPUT DELAY VALUE	DLL/ DELAY CHAIN SELECT	DLL REF FREQUENCY	DELAY BUFFER DURATION
High Speed DDR	8-bit PHY operating 1.8 V, 50 MHz	0x0	0x1	0x6	0x1	Tuning	0x0	0x4	0x7
HS200	8-bit PHY operating 1.8 V, 200 MHz	0x0	0x1	0x8	0x1	Tuning	0x0	0x0	0x7
HS400	8-bit PHY operating 1.8 V, 200 MHz	0x66	0x1	0x5	0x1	Tuning	0x0	0x0	0x7

表 7-58 presents timing conditions for MMC0.

表 7-58. MMC0 Timing Conditions

PARAMETER		MIN	MAX	UNIT	
<b>INPUT CONDITIONS</b>					
SR <sub>i</sub>	Input slew rate	Legacy SDR	0.14	1.44	V/ns
		High Speed SDR	0.3	0.90	V/ns
		High Speed DDR (CMD)	0.3	0.90	V/ns
		High Speed DDR (DAT[7:0])	0.45	0.90	V/ns
<b>OUTPUT CONDITIONS</b>					
C <sub>L</sub>	Output load capacitance	HS200, HS400	1	6	pF
		All other modes	1	12	pF
<b>PCB CONNECTIVITY REQUIREMENTS</b>					
t <sub>d</sub> (Trace Delay)	Propagation delay of each trace	All modes	134	756	ps
t <sub>d</sub> (Trace Mismatch Delay)	Propagation delay mismatch across all traces	Legacy SDR, High Speed SDR, High Speed DDR		100	ps
		HS200, HS400		8	ps

### 7.10.5.17.1.1 Legacy SDR Mode

表 7-59, 图 7-77, 表 7-60, and 图 7-78 present timing requirements and switching characteristics for MMC0 - Legacy SDR Mode.

表 7-59. MMC0 Timing Requirements - Legacy SDR Mode

see 图 7-77

NO.			MIN	MAX	UNIT
LSDR1	$t_{su}(cmdV-clkH)$	Setup time, MMC0_CMD valid before MMC0_CLK rising edge	2.5		ns
LSDR2	$t_h(clkH-cmdV)$	Hold time, MMC0_CMD valid after MMC0_CLK rising edge	6.5		ns
LSDR3	$t_{su}(dV-clkH)$	Setup time, MMC0_DAT[7:0] valid before MMC0_CLK rising edge	2.5		ns
LSDR4	$t_h(clkH-dV)$	Hold time, MMC0_DAT[7:0] valid after MMC0_CLK rising edge	6.5		ns



图 7-77. MMC0 - Legacy SDR - Receive Mode

表 7-60. MMC0 Switching Characteristics - Legacy SDR Mode

see 图 7-78

NO.	PARAMETER		MIN	MAX	UNIT
	$f_{op}(clk)$	Operating frequency, MMC0_CLK		25	MHz
LSDR5	$t_c(clk)$	Cycle time, MMC0_CLK	40		ns
LSDR6	$t_w(clkH)$	Pulse duration, MMC0_CLK high	18.7		ns
LSDR7	$t_w(clkL)$	Pulse duration, MMC0_CLK low	18.7		ns
LSDR8	$t_d(clkL-cmdV)$	Delay time, MMC0_CLK falling edge to MMC0_CMD transition	- 3.2	3.8	ns
LSDR9	$t_d(clkL-dV)$	Delay time, MMC0_CLK falling edge to MMC0_DAT[7:0] transition	- 3.2	3.8	ns

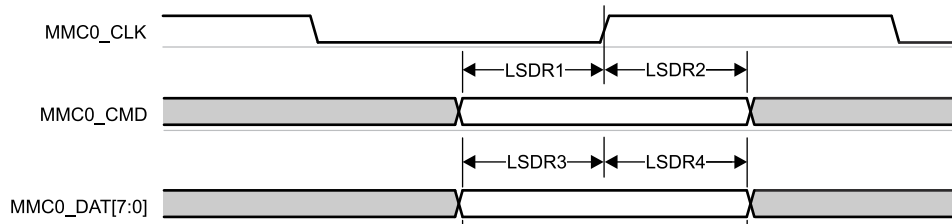

图 7-78. MMC0 - Legacy SDR - Transmit Mode

**7.10.5.17.1.2 High Speed SDR Mode**

表 7-61, 图 7-79, 表 7-62, and 图 7-80 present timing requirements and switching characteristics for MMC0 - High Speed SDR Mode.

**表 7-61. MMC0 Timing Requirements - High Speed SDR Mode**

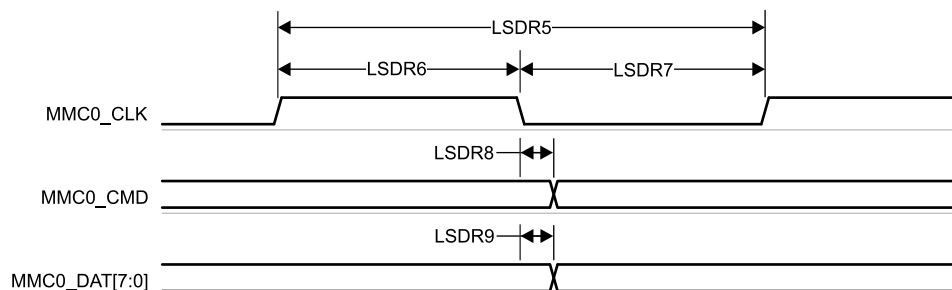
see 图 7-79

NO.			MIN	MAX	UNIT
HSSDR1	$t_{su(cmdV-clkH)}$	Setup time, MMC0_CMD valid before MMC0_CLK rising edge	2.99		ns
HSSDR2	$t_{h(clkH-cmdV)}$	Hold time, MMC0_CMD valid after MMC0_CLK rising edge	2.67		ns
HSSDR3	$t_{su(dV-clkH)}$	Setup time, MMC0_DAT[7:0] valid before MMC0_CLK rising edge	2.99		ns
HSSDR4	$t_{h(clkH-dV)}$	Hold time, MMC0_DAT[7:0] valid after MMC0_CLK rising edge	2.67		ns

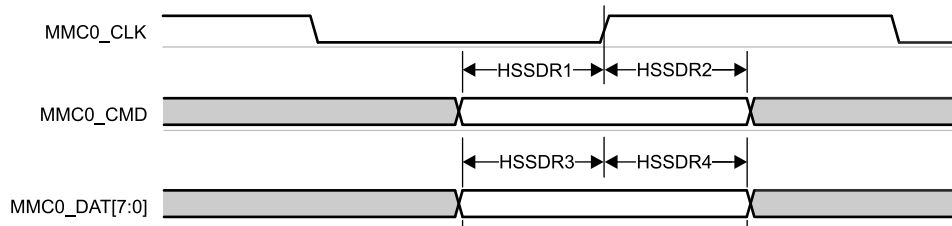

**图 7-79. MMC0 - High Speed SDR Mode - Receive Mode**

**表 7-62. MMC0 Switching Characteristics - High Speed SDR Mode**

see 图 7-80

NO.	PARAMETER		MIN	MAX	UNIT
	$f_{op(clk)}$	Operating frequency, MMC0_CLK		50	MHz
HSSDR5	$t_{c(clk)}$	Cycle time, MMC0_CLK	20		ns
HSSDR6	$t_{w(clkH)}$	Pulse duration, MMC0_CLK high	9.2		ns
HSSDR7	$t_{w(clkL)}$	Pulse duration, MMC0_CLK low	9.2		ns
HSSDR8	$t_{d(clkL-cmdV)}$	Delay time, MMC0_CLK falling edge to MMC0_CMD transition	- 3.2	3.8	ns
HSSDR9	$t_{d(clkL-dV)}$	Delay time, MMC0_CLK falling edge to MMC0_DAT[7:0] transition	- 3.2	3.8	ns

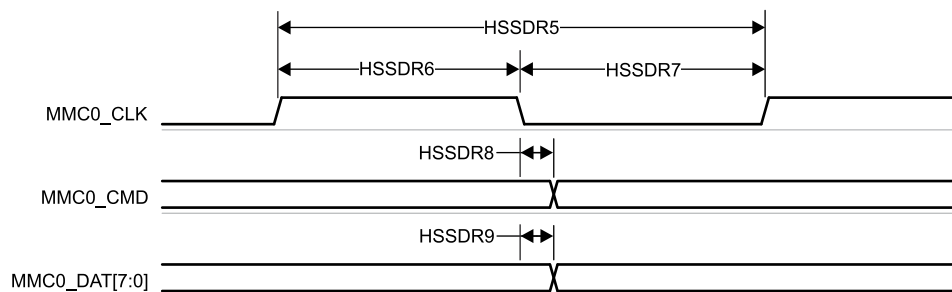

**图 7-80. MMC0 - High Speed SDR Mode - Transmit Mode**

### 7.10.5.17.1.3 High Speed DDR Mode

表 7-63, 图 7-81, 表 7-64, and 图 7-82 present timing requirements and switching characteristics for MMC0 - High Speed DDR Mode.

表 7-63. MMC0 Timing Requirements - High Speed DDR Mode

see 图 7-81

NO.			MIN	MAX	UNIT
HSDDR1	$t_{su(cmdV-clkH)}$	Setup time, MMC0_CMD valid before MMC0_CLK rising edge	3.79		ns
HSDDR2	$t_{h(clkH-cmdV)}$	Hold time, MMC0_CMD valid after MMC0_CLK rising edge	2.67		ns
HSDDR3	$t_{su(dV-clkV)}$	Setup time, MMC0_DAT[7:0] valid before MMC0_CLK transition	0.74		ns
HSDDR4	$t_{h(clkV-dV)}$	Hold time, MMC0_DAT[7:0] valid after MMC0_CLK transition	1.67		ns



图 7-81. MMC0 - High Speed DDR Mode - Receive Mode

表 7-64. MMC0 Switching Characteristics - High Speed DDR Mode

see 图 7-82

NO.	PARAMETER	MIN	MAX	UNIT	
	$f_{op(clk)}$	Operating frequency, MMC0_CLK	50	MHz	
HSDDR5	$t_{c(clk)}$	Cycle time, MMC0_CLK	20	ns	
HSDDR6	$t_{w(clkH)}$	Pulse duration, MMC0_CLK high	9.2	ns	
HSDDR7	$t_{w(clkL)}$	Pulse duration, MMC0_CLK low	9.2	ns	
HSDDR8	$t_{d(clkH-cmdV)}$	Delay time, MMC0_CLK rising edge to MMC0_CMD transition	3.4	9.8	ns
HSDDR9	$t_{d(clkV-dV)}$	Delay time, MMC0_CLK transition to MMC0_DAT[7:0] transition	2.9	6.85	ns

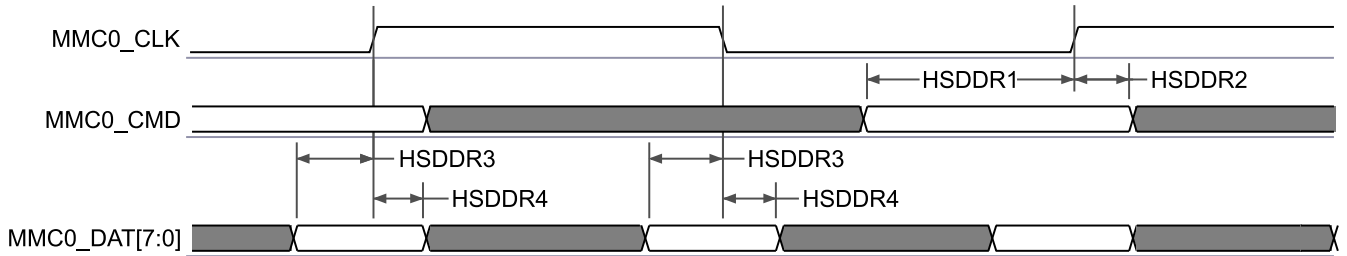

图 7-82. MMC0 - High Speed DDR Mode - Transmit Mode

### 7.10.5.17.1.4 HS200 Mode

表 7-65 和 图 7-83 呈现 MMC0 - HS200 Mode 的切换特性。

表 7-65. MMC0 Switching Characteristics - HS200 Mode

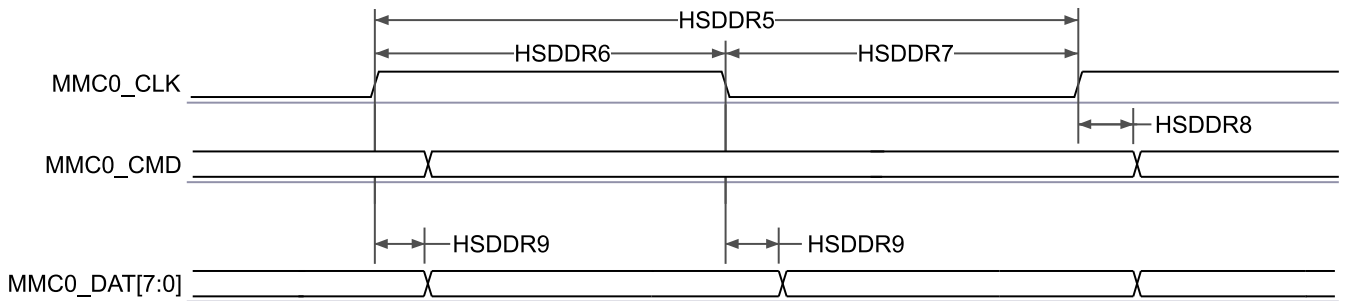
see 图 7-83

NO.	PARAMETER	MIN	MAX	UNIT	
	$f_{op}(clk)$	Operating frequency, MMC0_CLK		200	MHz
HS2005	$t_{c}(clk)$	Cycle time, MMC0_CLK		5	ns
HS2006	$t_{w}(clkH)$	Pulse duration, MMC0_CLK high		2.08	ns
HS2007	$t_{w}(clkL)$	Pulse duration, MMC0_CLK low		2.08	ns
HS2008	$t_{d}(clkL-cmdV)$	0.99	3.16	ns	
HS2009	$t_{d}(clkL-dV)$	0.99	3.16	ns	



图 7-83. MMC0 - HS200 Mode - Transmit Mode

### 7.10.5.17.1.5 HS400 Mode

表 7-66 和 图 7-84 呈现 MMC0 - HS400 Mode 的切换特性。

表 7-66. MMC0 Switching Characteristics - HS400 Mode

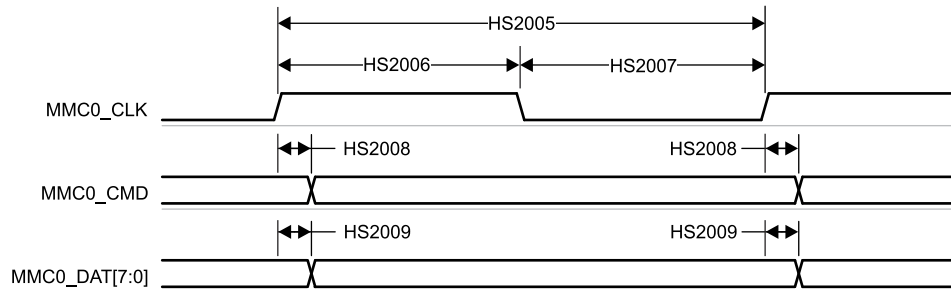
see 图 7-84

NO.	PARAMETER	DESCRIPTION	MIN	MAX	UNIT
	$f_{op}(clk)$	Operating frequency, MMC0_CLK	200		MHz
HS4005	$t_{c}(clk)$	Cycle time, MMC0_CLK	5		ns
HS4006	$t_{w}(clkH)$	Pulse duration, MMC0_CLK high	2.08		ns
HS4007	$t_{w}(clkL)$	Pulse duration, MMC0_CLK low	2.08		ns
HS4008	$t_{d}(clkH-cmdV)$	Delay time, MMC0_CLK rising clock edge to MMC0_CMD transition	0.99	3.28	ns
HS4009	$t_{d}(clkV-dV)$	Delay time, MMC0_CLK transition to MMC0_DAT[7:0] transition	0.59	1.84	ns



图 7-84. eMMC in - HS400 Mode - Transmitter Mode

### 7.10.5.17.2 MMC1/2 - SD/SDIO Interface

MMC1 interface is compliant with the SD Host Controller Standard Specification 4.10 and SD Physical Layer Specification v3.01 as well as SDIO Specification v3.00 and they support the following SD Card applications:

- Default speed
- High speed
- UHS - I SDR12
- UHS - I SDR25
- UHS - I SDR50
- UHS - I SDR104
- UHS - I DDR50

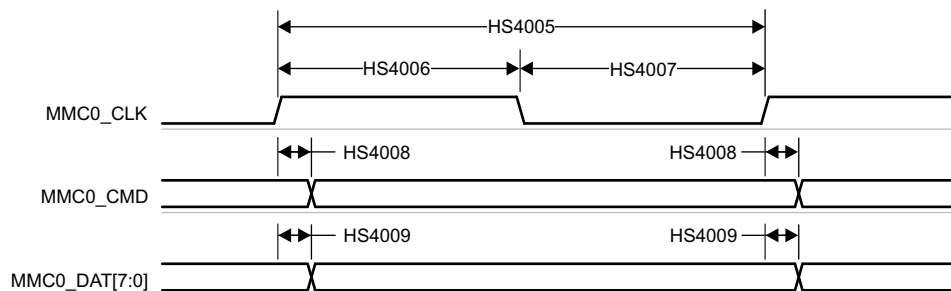
表 7-67 presents the required DLL software configuration settings for MMC1 timing modes.

**表 7-67. MMC1 DLL Delay Mapping for All Timing Modes**

REGISTER NAME		MMCSD12_SS_PHY_CTRL_4_REG				MMCSD12_SS_PHY_CTRL_5_REG
BIT FIELD		[20]	[15:12]	[8]	[4:0]	[2:0]
BIT FIELD NAME		OTAPDLYENA	OTAPDLYSEL	ITAPDLYENA	ITAPDLYSEL	CLKBUFSEL
MODE	DESCRIPTION	DELAY ENABLE	DELAY VALUE	INPUT DELAY ENABLE	INPUT DELAY VALUE	DELAY BUFFER DURATION
Default Speed	4-bit PHY operating 3.3 V, 25 MHz	0x0	0x0	0x0	0x0	0x7
High Speed	4-bit PHY operating 3.3 V, 50 MHz	0x0	0x0	0x0	0x0	0x7
UHS-I SDR12	4-bit PHY operating 1.8 V, 25 MHz	0x1	0xF	0x0	0x0	0x7
UHS-I SDR25	4-bit PHY operating 1.8 V, 50 MHz	0x1	0xF	0x0	0x0	0x7
UHS-I SDR50	4-bit PHY operating 1.8 V, 100 MHz	0x1	0xC	0x1	Tuning	0x7
UHS-I DR50	4-bit PHY operating 1.8 V, 50 MHz	0x1	0xC	0x1	0x2	0x7
UHS-I SDR104	4-bit PHY operating 1.8 V, 200 MHz	0x1	0x5	0x1	Tuning	0x7

表 7-68 presents timing conditions for MMC1.

**表 7-68. MMC1 Timing Conditions**

PARAMETER			MIN	MAX	UNIT
<b>INPUT CONDITIONS</b>					
SR <sub>i</sub>	Input slew rate	Default Speed, High Speed	0.69	2.06	V/ns
		UHS - I SDR12, UHS - I SDR25	0.34	1.34	V/ns
		USH-1 DDR50	1.00	2.00	V/ns
<b>OUTPUT CONDITIONS</b>					
C <sub>L</sub>	Output load capacitance	All modes	1	10	pF
<b>PCB CONNECTIVITY REQUIREMENTS</b>					
t <sub>d</sub> (Trace Delay)	Propagation delay of each trace	UHS - I DDR50	240.03	1134	ps
		All other modes	126	1386	ps
t <sub>d</sub> (Trace Mismatch Delay)	Propagation delay mismatch across all traces	UHS - I DDR50		20	ps
		UHS - I SDR104		8	ps
		All other modes		100	ps

7.10.5.17.2.1 Default Speed Mode

表 7-69, 图 7-85, 表 7-70, and 图 7-86 present timing requirements and switching characteristics for MMC1/2 - Default Speed Mode.

表 7-69. MMC1/2 Timing Requirements - Default Speed Mode

see 图 7-85

NO.			MIN	MAX	UNIT
DS1	$t_{su}(cmdV-clkH)$	Setup time, MMC[x]_CMD valid before MMC[x]_CLK rising edge	2.15		ns
DS2	$t_h(clkH-cmdV)$	Hold time, MMC[x]_CMD valid after MMC[x]_CLK rising edge	4.56		ns
DS3	$t_{su}(dV-clkH)$	Setup time, MMC[x]_DAT[3:0] valid before MMC[x]_CLK rising edge	2.15		ns
DS4	$t_h(clkH-dV)$	Hold time, MMC[x]_DAT[3:0] valid after MMC[x]_CLK rising edge	4.56		ns

A. x = 1, 2 for MMC1 and MMC2

B. x = 1, 2 for MMC1 and MMC2



图 7-85. MMC1/2 - Default Speed - Receive Mode

表 7-70. MMC1/2 Switching Characteristics - Default Speed Mode

see 图 7-86

NO.	PARAMETER	MIN	MAX	UNIT
	$f_{op}(clk)$		25	MHz
DS5	$t_c(clk)$	40		ns
DS6	$t_w(clkH)$	18.7		ns
DS7	$t_w(clkL)$	18.7		ns
DS8	$t_d(clkL-cmdV)$	- 3.53	3.53	ns
DS9	$t_d(clkL-dV)$	- 3.53	3.53	ns

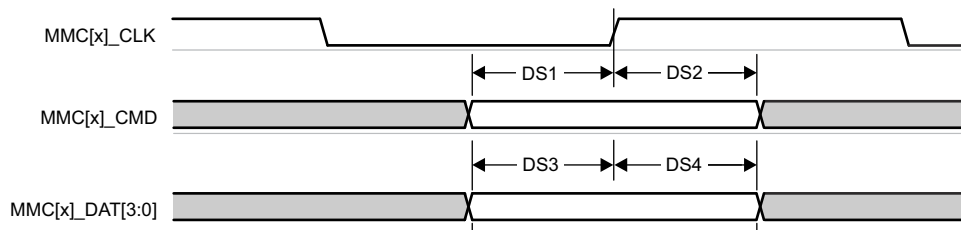

图 7-86. MMC1/2 - Default Speed - Transmit Mode

### 7.10.5.17.2.2 High Speed Mode

表 7-71, 图 7-87, 表 7-72, 和 图 7-88 present timing requirements and switching characteristics for MMC1/2 - High Speed Mode.

表 7-71. MMC1/2 Timing Requirements - High Speed Mode

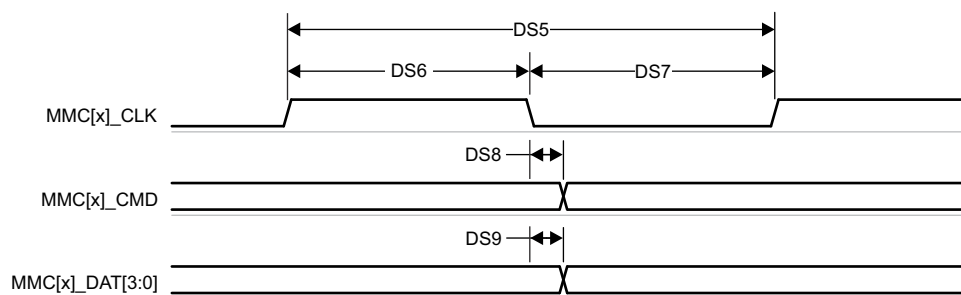
see 图 7-87

NO.			MIN	MAX	UNIT
HS1	$t_{su}(cmdV-clkH)$	Setup time, MMC[x]_CMD valid before MMC[x]_CLK rising edge	2.15		ns
HS2	$t_h(clkH-cmdV)$	Hold time, MMC[x]_CMD valid after MMC[x]_CLK rising edge	2.26		ns
HS3	$t_{su}(dV-clkH)$	Setup time, MMC[x]_DAT[3:0] valid before MMC[x]_CLK rising edge	2.15		ns
HS4	$t_h(clkH-dV)$	Hold time, MMC[x]_DAT[3:0] valid after MMC[x]_CLK rising edge	2.26		ns

- A. x = 1, 2 for MMC1 and MMC2
- B. x = 1, 2 for MMC1 and MMC2



图 7-87. MMC1 /2 - High Speed - Receive Mode

表 7-72. MMC1/2 Switching Characteristics - High Speed Mode

see 图 7-88

NO.	PARAMETER	MIN	MAX	UNIT
	$f_{op}(clk)$		50	MHz
HS5	$t_{c}(clk)$	20		ns
HS6	$t_w(clkH)$	9.2		ns
HS7	$t_w(clkL)$	9.2		ns
HS8	$t_d(clkL-cmdV)$	- 2.07	2.07	ns
HS9	$t_d(clkL-dV)$	- 2.07	2.07	ns

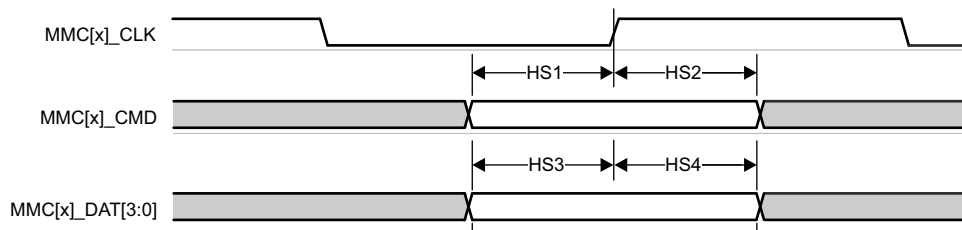

图 7-88. MMC1/2 - High Speed - Transmit Mode

## 7.10.5.17.2.3 UHS -I SDR12 Mode

表 7-73, 图 7-89, 表 7-74, 和 图 7-90 present timing requirements and switching characteristics for MMC1/2 - UHS-I SDR12 Mode.

表 7-73. MMC1/2 Timing Requirements - UHS-I SDR12 Mode

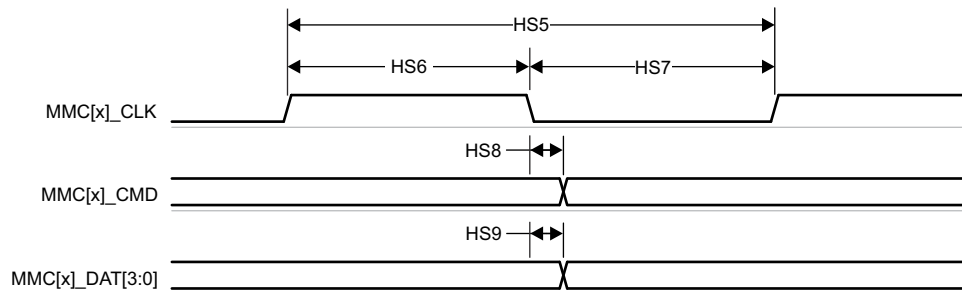
see 图 7-89

NO.			MIN	MAX	UNIT
SDR121	$t_{su(cmdV-clkH)}$	Setup time, MMC[x]_CMD valid before MMC[x]_CLK rising edge	5.46		ns
SDR122	$t_{h(clkH-cmdV)}$	Hold time, MMC[x]_CMD valid after MMC[x]_CLK rising edge	1.67		ns
SDR123	$t_{su(dV-clkH)}$	Setup time, MMC[x]_DAT[3:0] valid before MMC[x]_CLK rising edge	5.46		ns
SDR124	$t_{h(clkH-dV)}$	Hold time, MMC[x]_DAT[3:0] valid after MMC[x]_CLK rising edge	1.67		ns

A. x = 1, 2 for MMC1 and MMC2

B. x = 1, 2 for MMC1 and MMC2



图 7-89. MMC1/2 - UHS-I SDR12 - Receive Mode

表 7-74. MMC1/2 Switching Characteristics - UHS-I SDR12 Mode

see 图 7-90

NO.	PARAMETER	MIN	MAX	UNIT
	$f_{op(clk)}$		25	MHz
SDR125	$t_{c(clk)}$	40		ns
SDR126	$t_{w(clkH)}$	18.7		ns
SDR127	$t_{w(clkL)}$	18.7		ns
SDR128	$t_{d(clkH-cmdV)}$	1.2	13.55	ns
SDR129	$t_{d(clkH-dV)}$	1.2	13.55	ns

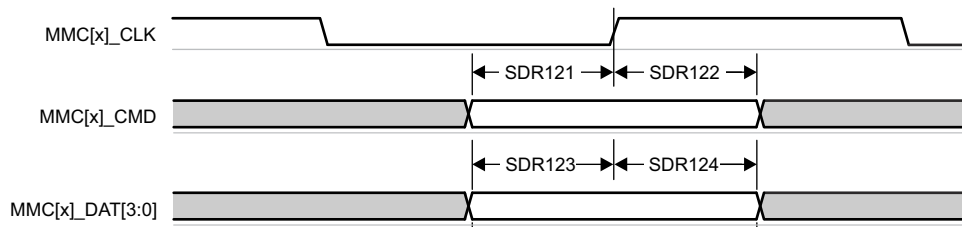

图 7-90. MMC1/2 - UHS-I SDR12 - Transmit Mode

### 7.10.5.17.2.4 UHS -I SDR25 Mode

表 7-75, 图 7-91, 表 7-76, 和 图 7-92 present timing requirements and switching characteristics for MMC1/2 - UHS-I SDR25 Mode.

表 7-75. MMC1/2 Timing Requirements - UHS-I SDR25 Mode

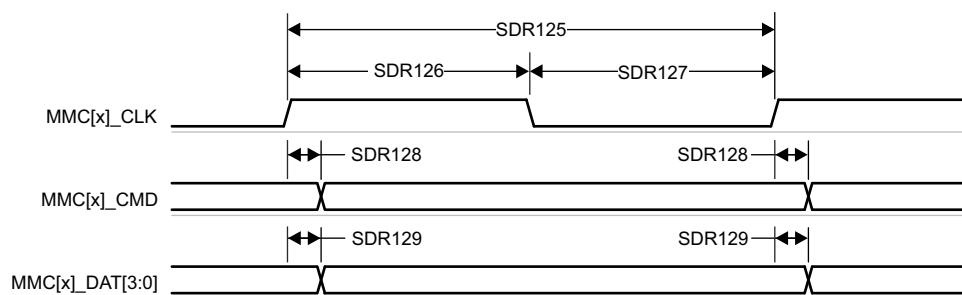
see 图 7-91

NO.			MIN	MAX	UNIT
SDR251	$t_{su(cmdV-clkH)}$	Setup time, MMC[x]_CMD valid before MMC[x]_CLK rising edge	2.1		ns
SDR252	$t_{h(clkH-cmdV)}$	Hold time, MMC[x]_CMD valid after MMC[x]_CLK rising edge	1.67		ns
SDR253	$t_{su(dV-clkH)}$	Setup time, MMC[x]_DAT[3:0] valid before MMC[x]_CLK rising edge	2.1		ns
SDR254	$t_{h(clkH-dV)}$	Hold time, MMC[x]_DAT[3:0] valid after MMC[x]_CLK rising edge	1.67		ns

- A. x = 1, 2 for MMC1 and MMC2  
B. x = 1, 2 for MMC1 and MMC2



图 7-91. MMC1/2 - UHS-I SDR25 - Receive Mode

表 7-76. MMC1/2 Switching Characteristics - UHS-I SDR25 Mode

see 图 7-92

NO.	PARAMETER	MIN	MAX	UNIT
	$f_{op(clk)}$		50	MHz
SDR255	$t_{c(clk)}$	20		ns
SDR256	$t_{w(clkH)}$	9.2		ns
SDR257	$t_{w(clkL)}$	9.2		ns
SDR258	$t_{d(clkH-cmdV)}$	2.4	9.37	ns
SDR259	$t_{d(clkH-dV)}$	2.4	9.37	ns

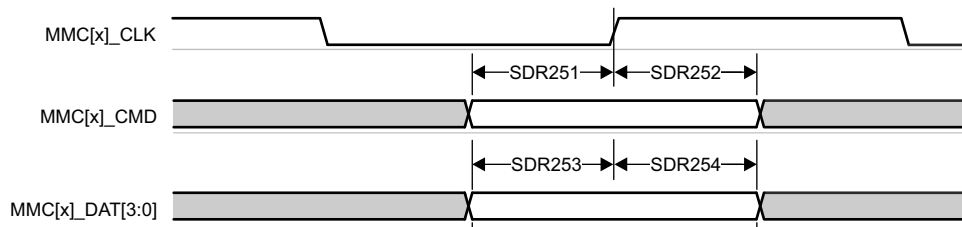

图 7-92. MMC1/2 - UHS-I SDR25 - Transmit Mode

7.10.5.17.2.5 UHS -I SDR50 Mode

表 7-77, and 图 7-93 presents switching characteristics for MMC1/2 - UHS-I SDR50 Mode.

表 7-77. MMC1/2 Switching Characteristics - UHS-I SDR50 Mode

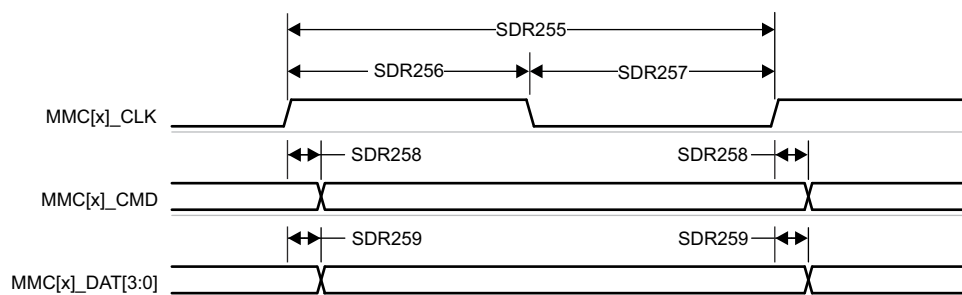
see 图 7-93

NO.	PARAMETER		MIN	MAX	UNIT
	$f_{op}(clk)$	Operating frequency, MMC[x]_CLK		100	MHz
SDR505	$t_{c}(clk)$	Cycle time, MMC[x]_CLK	10		ns
SDR506	$t_{w}(clkH)$	Pulse duration, MMC[x]_CLK high	4.45		ns
SDR507	$t_{w}(clkL)$	Pulse duration, MMC[x]_CLK low	4.45		ns
SDR508	$t_{d}(clkH-cmdV)$	Delay time, MMC[x]_CLK rising edge to MMC[x]_CMD transition	1.2	6.35	ns
SDR509	$t_{d}(clkH-dV)$	Delay time, MMC[x]_CLK rising edge to MMC[x]_DAT[3:0] transition	1.2	6.35	ns

A. x = 1, 2 for MMC1 and MMC2



图 7-93. MMC1/2 - UHS-I SDR50 - Transmit Mode

7.10.5.17.2.6 UHS -I DDR50 Mode

表 7-78 和 图 7-94 present switching characteristics for MMC1/2 - UHS-I DDR50 Mode.

表 7-78. MMC1/2 Switching Characteristics - UHS-I DDR50 Mode

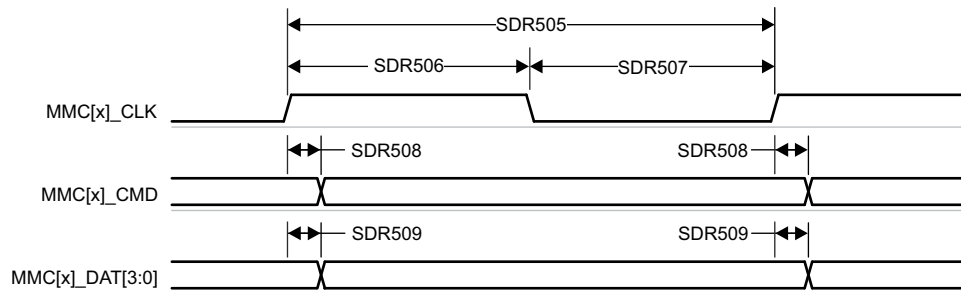
see 图 7-94

NO.	PARAMETER	MIN	MAX	UNIT
	$f_{op}(clk)$		40	MHz
DDR505	$t_{c}(clk)$	25		ns
DDR506	$t_{w}(clkH)$	9.2		ns
DDR507	$t_{w}(clkL)$	9.2		ns
DDR508	$t_{d}(clkH-cmdV)$	1.12	3.46	ns
DDR509	$t_{d}(clk-dV)$	1.12	6.12	ns

A. x = 1, 2 for MMC1 and MMC2



图 7-94. MMC1/2 - UHS-I DDR50 - Transmit Mode

### 7.10.5.17.2.7 UHS -I SDR104 Mode

表 7-79, and 图 7-95 present switching characteristics for MMC1/2 - UHS-I SDR104 Mode.

表 7-79. MMC1/2 Switching Characteristics - UHS-I SDR104 Mode

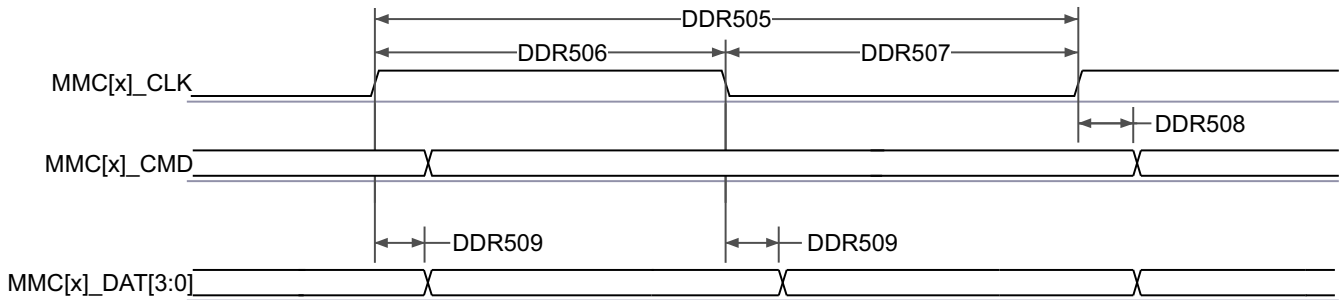
see 图 7-95

NO.	PARAMETER		MIN	MAX	UNIT
	$f_{op(\text{clk})}$	Operating frequency, MMC[x]_CLK		200	MHz
SDR1045	$t_{c(\text{clk})}$	Cycle time, MMC[x]_CLK	5		ns
SDR1046	$t_{w(\text{clkH})}$	Pulse duration, MMC[x]_CLK high	2.12		ns
SDR1047	$t_{w(\text{clkL})}$	Pulse duration, MMC[x]_CLK low	2.12		ns
SDR1048	$t_{d(\text{clkH-cmdV})}$	Delay time, MMC[x]_CLK rising edge to MMC[x]_CMD transition	1.07	3.21	ns
SDR1049	$t_{d(\text{clkH-dV})}$	Delay time, MMC[x]_CLK rising edge to MMC[x]_DAT[3:0] transition	1.07	3.21	ns

A. x = 1, 2 for MMC1 and MMC2



图 7-95. MMC1/2 - UHS-I SDR104 - Transmit Mode

### 7.10.5.18 CPTS

表 7-80 represents CPTS timing conditions.

表 7-80. CPTS Timing Conditions

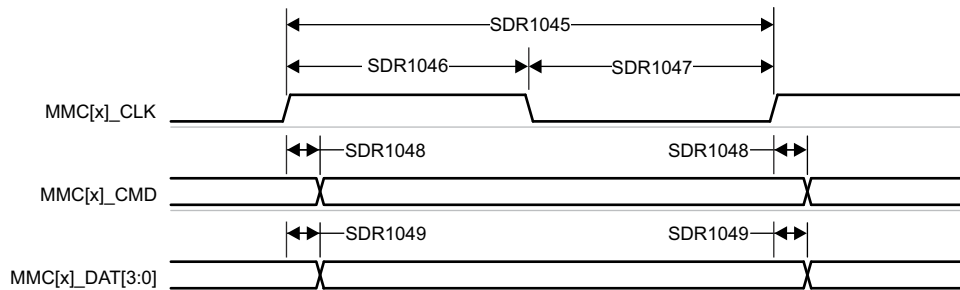
PARAMETER	DESCRIPTION	MIN	MAX	UNIT
<b>INPUT CONDITIONS</b>				
$SR_i$	Input slew rate	0.5	5	V/ns
<b>OUTPUT CONDITIONS</b>				
$C_L$	Output load capacitance	2	10	pF

节 7.10.5.18.1, 节 7.10.5.18.2, 图 7-96, and 图 7-97 present timing requirements and switching characteristics of the CPTS interface.

#### 7.10.5.18.1 CPTS Timing Requirements

see 图 7-96

NO.	PARAMETER		MIN	MAX	UNIT
T1	$t_{w(\text{HWnTSPUSHH})}$	Pulse duration, HWnTSPUSH <sup>(2)</sup> high	$12P + 2^{(1)}$		ns
T2	$t_{w(\text{HWnTSPUSHL})}$	Pulse duration, HWnTSPUSH <sup>(2)</sup> low	$12P + 2^{(1)}$		ns
T3	$t_{c(\text{RFT\_CLK})}$	Cycle time, RFT_CLK	5	8	ns
T4	$t_{w(\text{RFT\_CLKH})}$	Pulse duration, RFT_CLK high	$0.45 * T^{(3)}$		ns
T5	$t_{w(\text{RFT\_CLKL})}$	Pulse duration, RFT_CLK low	$0.45 * T^{(3)}$		ns

(1) P = functional clock period in ns.

(2) In HWnTSPUSH, n = 1 to 2.

(3) T = RFT\_CLK period in ns.



图 7-96. CPTS Timing Requirements

### 7.10.5.18.2 CPTS Switching Characteristics

see 图 7-97

NO.	PARAMETER	SOURCE	MIN	MAX	UNIT
T6	$t_{w(TS\_COMP)}$	Pulse duration, TS_COMP high	$36P - 2^{(1)}$		ns
T7	$t_{w(TS\_COMPL)}$	Pulse duration, TS_COMP low	$36P - 2^{(1)}$		ns
T8	$t_{w(TS\_SYNCH)}$	Pulse duration, TS_SYNC high	$36P - 2^{(1)}$		ns
T9	$t_{w(TS\_SYNCL)}$	Pulse duration, TS_SYNC low	$36P - 2^{(1)}$		ns
T10	$t_{w(SYNc\_OUTH)}$	TS_SYNC	$36P - 2^{(1)}$		ns
		TS_GENF	$5P - 2^{(1)}$		ns
T11	$t_{w(SYNc\_OUTL)}$	TS_SYNC	$36P - 2^{(1)}$		ns
		TS_GENF	$5P - 2^{(1)}$		ns

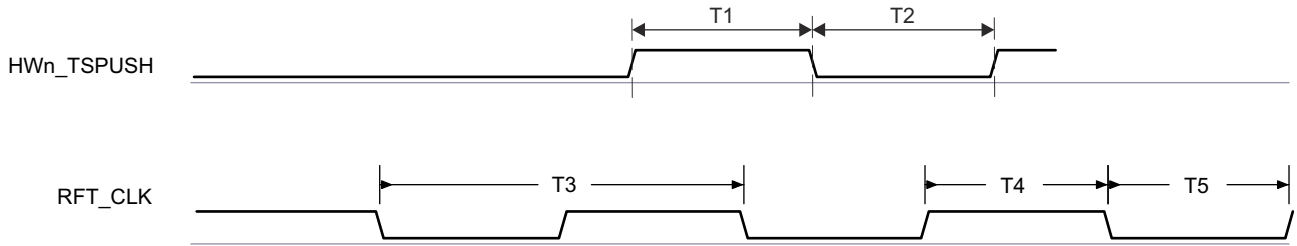
- (1) P = functional clock period in ns.  
 (2) n = 0 to 3 in SYNc\_n\_OUT



图 7-97. CPTS Switching Characteristics

For more information, see *Navigator Subsystem (NAVSS)* section in *Data Movement Architecture (DMA)* chapter in the device TRM.

### 7.10.5.19 OSPI

For more details about features and additional description information on the device Octal Serial Peripheral Interface, see the corresponding sections within [Signal Descriptions](#) and *Detailed Description*.

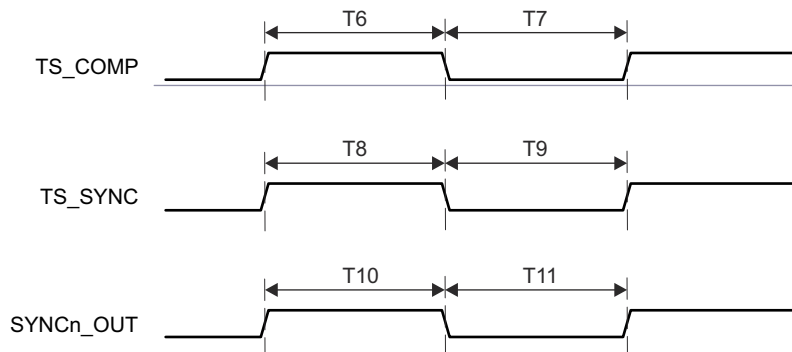
表 7-81 represents OSPI timing conditions.

表 7-81. OSPI Timing Conditions

PARAMETER	MIN	MAX	UNIT
<b>INPUT CONDITIONS</b>			
SR <sub>i</sub>	Input slew rate	3.3 V	2
		All other modes	1
<b>OUTPUT CONDITIONS</b>			

表 7-81. OSPI Timing Conditions (continued)

PARAMETER			MIN	MAX	UNIT
$C_L$	Output load capacitance	All modes	3	10	pF
<b>PCB CONNECTIVITY REQUIREMENTS</b>					
$t_d$ (Trace Delay)	Propagation delay OSPI_CLK trace	No Loopback; Internal Pad Loopback		450	ps
	Propagation delay OSPI_LBCLKO trace	External Board Loopback	$2*L-30^{(2)}$	$2*L+30^{(2)}$	ps
	Propagation delay OSPI_DQS trace	DQS	$L-30^{(2)}$	$L+30^{(2)}$	ps
$t_d$ (Trace Mismatch Delay)	Propagation delay mismatch OSPI_D[i:0] <sup>(1)</sup> , OSPI_CS <i>n</i> relative to OSPI_CLK	All modes		60	ps

(1)  $i$  in D[i:0] = 0 to 7 for OSPI0;  $i$  in [i:0] = 3 for OSPI1(2)  $L$  = Propagation delay of OSPI\_CLK trace

### 7.10.5.19.1 OSPI0 PHY Mode

#### 7.10.5.19.1.1 OSPI With Data Training

备注

I/O timing requirements and switching characteristics are not applicable when OSPI is used with data training. Follow the [OSPI and QSPI Board Design and Layout Guidelines](#) section to ensure proper operation.

##### 7.10.5.19.1.1.1 OSPI Switching Characteristics - Data Training

PARAMETER	DESCRIPTION	MODE	MIN	MAX	UNIT
$t_{c(\text{CLK})}$	Cycle time, CLK	DDR, 1.8V	6		ns
		DDR, 3.3V	7.5		ns
$t_{c(\text{CLK})}$	Cycle time, CLK	SDR, 1.8V	6		ns
		SDR, 3.3V	7.5		ns

##### 7.10.5.19.1.2 OSPI Without Data Training

备注

The I/O Timings provided in this section are only applicable when data training is not implemented. Additionally, the I/O Timings are valid only for some OSPI usage modes when the corresponding DLL Delays are configured as described in [表 7-82](#) found in this section.

节 7.10.5.19.1.2.4, 节 7.10.5.19.1.2.2, 节 7.10.5.19.1.2, and 节 7.10.5.19.1.2 present switching characteristics for OSPI DDR and SDR Mode.

##### 7.10.5.19.1.2.1 OSPI Timing Requirements - SDR Mode

表 7-82. OSPI DLL Delay Mapping - SDR Timing Modes

MODE	OSPI_PHY_CONFIGURATION_REG BIT FIELD	DELAY VALUE
All modes	PHY_CONFIG_TX_DLL_DELAY_FLD	0x0
	PHY_CONFIG_RX_DLL_DELAY_FLD	0x0

表 7-83. OSPI Timing Requirements - SDR Mode

NO.	PARAMETER	DESCRIPTION	MODE	MIN	MAX	UNIT
O21	$t_{su(D-LBCLK)}$	Setup time, D[i:0] valid before active LBCLK input (DQS) edge <sup>(1)</sup>	1.8V, External Board Loopback	0.6		ns
			3.3V, External Board Loopback	0.9		ns
O22	$t_h(LBCLK-D)$	Hold time, D[i:0] valid after active LBCLK input (DQS) edge <sup>(1)</sup>	1.8V, External Board Loopback	1.7		ns
			3.3V, External Board Loopback	2		ns

(1) i in [i:0] = 7 for OSPI0, i in [i:0] = 3 for OSPI1



图 7-98. OSPI Timing Requirements - SDR, External Loopback Clock

**7.10.5.19.1.2.2 OSPI Switching Characteristics - SDR Mode**

NO.	PARAMETER	DESCRIPTION	MODE	MIN	MAX	UNIT
O7	t <sub>c</sub> (CLK)	Cycle time, CLK	1.8V	7		ns
			3.3V	7.5		ns
O8	t <sub>w</sub> (CLKL)	Pulse duration, CLK low		- 0.3+0.475*P (2)		ns
O9		Pulse duration, CLK high		- 0.3+0.475*P (2)		ns
O10	t <sub>td</sub> (CSn-CLK)	Delay time, CSn[3:0] active edge to CLK rising edge	1.8V	0.475 * P + 0.975 * M * R - 7 (2) (3) (5)	0.525 * P + 1.025 * M * R + 1 (2) (3) (5)	ns
			3.3V	0.475 * P + 0.975 * M * R - 7(2) (3) (5)	0.525 * P + 1.025 * M * R + 1 (2) (3) (5)	ns
O11	t <sub>d</sub> (CLK-CSn)	Delay time, CLK rising edge to CSn inactive edge	1.8V	0.475 * P + 0.975 * N * R - 1 (2) (4) (5)	0.525 * P + 1.025 * N * R + 1 (2) (4) (5)	ns
			3.3V	0.475 * P + 0.975 * N * R - 1 (2) (4) (5)	0.525 * P + 1.025 * N * R + 1(2) (4) (5)	ns
O12	t <sub>d</sub> (CLK-D)	Delay time, CLK active edge to D[i:0] transition <sup>(1)</sup>	1.8V	- 1.16	1.25	ns
			3.3V	- 1.33	1.51	ns

- (1) i in [i:0] = 7 for OSPI0, i in [i:0] = 3 for OSPI1
- (2) P = CLK cycle time = SCLK period
- (3) M = OSPI\_DEV\_DELAY\_REG[D\_INIT\_FLD]
- (4) N = OSPI\_DEV\_DELAY\_REG[D\_AFTER\_FLD]
- (5) R = refclk

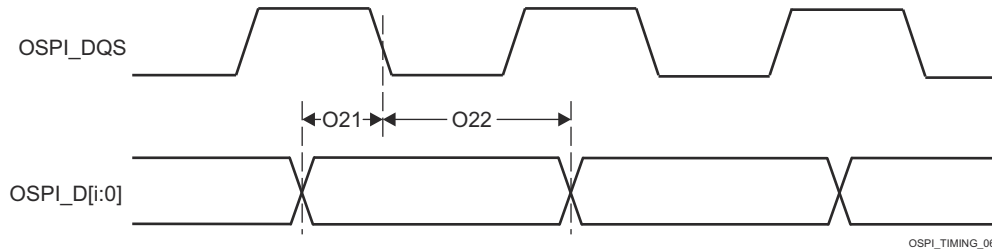
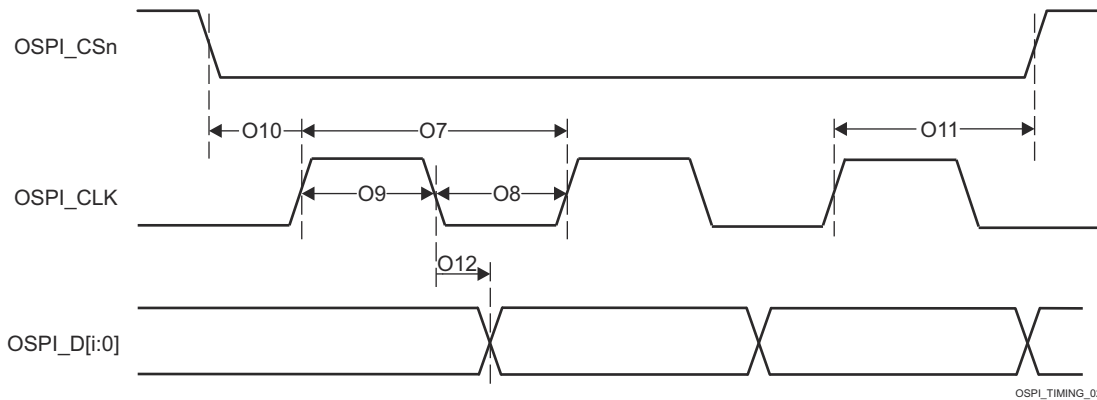

**图 7-99. OSPI Switching Characteristics - SDR**

节 7.10.5.19.1.2.3, 节 7.10.5.19.1.2.1, 节 7.10.5.19.1.2.2, 节 7.10.5.19.1.2.2, and 图 7-98 presents timing requirements for OSPI DDR and SDR Mode.

**7.10.5.19.1.2.3 OSPI Timing Requirements - DDR Mode**

**表 7-84. OSPI DLL Delay Mapping - DDR Timing Modes**

MODE	OSPI_PHY_CONFIGURATION_REG BIT FIELD	OSPI0	OSPI1
		DELAY VALUE	
<b>TRANSMIT</b>			
1.8V	PHY_CONFIG_TX_DLL_DELAY_FLD	0x54	0x54

表 7-84. OSPI DLL Delay Mapping - DDR Timing Modes (continued)

MODE	OSPI_PHY_CONFIGURATION_REG BIT FIELD	OSPI0	OSPI1
		DELAY VALUE	
3.3V	PHY_CONFIG_TX_DLL_DELAY_FLD	0x55	0x5C
<b>RECEIVE</b>			
1.8V, DQS	PHY_CONFIG_RX_DLL_DELAY_FLD	0x23	0x29
3.3V, DQS	PHY_CONFIG_RX_DLL_DELAY_FLD	0x47	0x42
All other modes	PHY_CONFIG_RX_DLL_DELAY_FLD	0x0	0x0

表 7-85. OSPI Timing Requirements - DDR Mode

NO.	PARAMETER	DESCRIPTION	MODE	MIN	MAX	UNIT
O15	$t_{su}(D-LBCLK)$	Setup time, D[i:0] valid before active LBCLK (DQS) edge <sup>(1)</sup>	1.8V, External Board Loopback	0.52		ns
			3.3V, External Board Loopback	1.97		ns
O16	$t_h(LBCLK-D)$	Hold time, D[i:0] valid after active LBCLK (DQS) edge <sup>(1)</sup>	1.8V, External Board Loopback	1.24 <sup>(2)</sup>		ns
			3.3V, External Board Loopback	1.44 <sup>(2)</sup>		ns
O17	$t_{su}(D-DQS)$	Setup time, DQS edge to D[i:0] transition <sup>(1)</sup>	1.8V, DQS	- 0.46		ns
			3.3V, DQS	- 0.66		ns
O18	$t_h(DQS-D)$	Hold time, DQS edge to D[i:0] transition <sup>(1)</sup>	1.8V, DQS	3.59		ns
			3.3V, DQS	8.89		ns

(1) i in [i:0] = 7 for OSPI0, i in [i:0] = 3 for OSPI1

(2) This Hold time requirement is larger than the Hold time provided by a typical flash device. Therefore, the trace length between the SoC and flash device must be sufficiently long enough to ensure that the Hold time is met at the SoC. Refer to [OSPI and QSPI Board Design and Layout Guidelines](#) for more details.



图 7-100. OSPI Timing Requirements - DDR, External Loopback Clock and DQS

#### 7.10.5.19.1.2.4 OSPI Switching Characteristics - DDR Mode

NO.	PARAMETER	DESCRIPTION	MODE	MIN	MAX	UNIT
O1	$t_c(CLK)$	Cycle time, CLK	1.8V	19		ns
			3.3V	19		ns
O2	$t_w(CLKL)$	Pulse duration, CLK low		$0.475 * P - 0.3$ <sup>(2)</sup>		ns
O3	$t_w(CLKH)$	Pulse duration, CLK high		$0.475 * P - 0.3$ <sup>(2)</sup>		ns
O4	$t_d(CLK-CSn)$	Delay time, CSn active edge to CLK rising edge	1.8V	$0.475 * P + 0.975 * M * R - 7$ <sup>(2) (3) (5)</sup>	$0.525 * P + 1.025 * M * R + 1$ <sup>(2) (3) (5)</sup>	ns
			3.3V	$0.475 * P + 0.975 * M * R - 7$ <sup>(2) (3) (5)</sup>	$0.525 * P + 1.025 * M * R + 1$ <sup>(2) (3) (5)</sup>	ns

NO.	PARAMETER	DESCRIPTION	MODE	MIN	MAX	UNIT
O5	$t_{d(CLK-CSn)}$	Delay time, CLK rising edge to CSn inactive edge	1.8V	$0.475 * P + 0.975 * N * R - 7^{(2) (4) (5)}$	$0.525 * P + 1.025 * N * R + 1^{(2) (4) (5)}$	ns
			3.3V, OSPI0 DDR TX; 3.3V, OSPI1 DDR TX	$0.475 * P + 0.975 * N * R - 7^{(2) (4) (5)}$	$0.525 * P + 1.025 * N * R + 1^{(2) (4) (5)}$	ns
O6	$t_{d(CLK-D)}$	Delay time, CLK active edge to D[i:0] transition <sup>(1)</sup>	1.8V, OSPI0 DDR TX; 1.8V, OSPI1 DDR TX	- 7.71	- 1.56	ns
			3.3V, OSPI0 DDR TX; 3.3V, OSPI1 DDR TX	- 7.71	- 1.56	ns

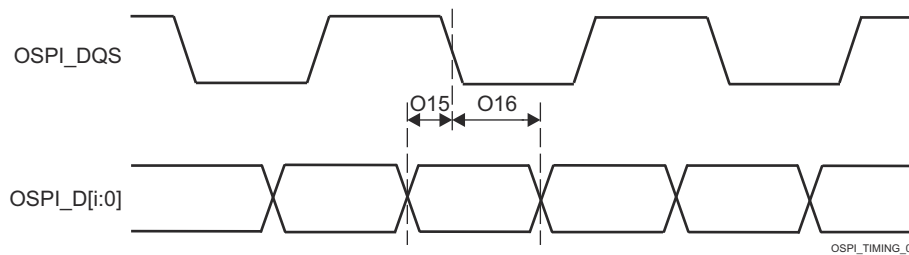
- (1) i in [i:0] = 7 for OSPI0, i in [i:0] = 3 for OSPI1
- (2) P = CLK cycle time = SCLK period
- (3) N = OSPI\_DEV\_DELAY\_REG[D\_INIT\_FLD]
- (4) N = OSPI\_DEV\_DELAY\_REG[D\_AFTER\_FLD]
- (5) R = refclk



图 7-101. OSPI Switching Characteristics - DDR

7.10.5.19.2 OSPI0 Tap Mode

7.10.5.19.2.1 OSPI0 Tap SDR Timing

表 7-86, 图 7-102, 表 7-87, and 图 7-103 present timing requirements and switching characteristics for OSPI0 Tap SDR Mode.

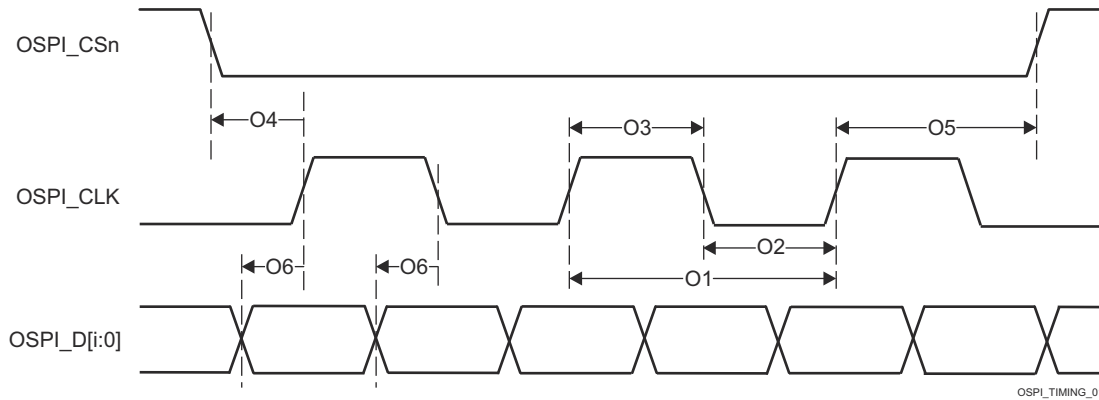
表 7-86. OSPI0/1 Timing Requirements - Tap SDR Mode

see 图 7-102

NO.		MODE	MIN	MAX	UNIT
O19	$t_{su(D-CLK)}$	Setup time, OSPI0/1_D[7:0] valid before active OSPI0/1_CLK edge	(10.4 - (0.975T <sup>(1)</sup> R <sup>(2)</sup> ))		ns
O20	$t_{h(CLK-D)}$	Hold time, OSPI0/1_D[7:0] valid after active OSPI0/1_CLK edge	(- 0.2 + (0.975T <sup>(1)</sup> R <sup>(2)</sup> ))		ns

- (1) T = OSPI\_RD\_DATA\_CAPTURE\_REG[DELAY\_FLD]
- (2) R = refclk cycle time in ns



图 7-102. OSPI0/1 Timing Requirements - Tap SDR, No Loopback

**表 7-87. OSPI0/1 Switching Characteristics - Tap SDR Mode**

see 图 7-103

NO.	PARAMETER		MODE	MIN	MAX	UNIT
O7	$t_{c(CLK)}$	Cycle time, OSPI0/1_CLK		20		ns
O8	$t_{w(CLKL)}$	Pulse duration, OSPI0/1_CLK low		$((0.475P^{(1)}) - 0.3)$		ns
O9	$t_{w(CLKH)}$	Pulse duration, OSPI0/1_CLK high		$((0.475P^{(1)}) - 0.3)$		ns
O10	$t_{d(CSn-CLK)}$	Delay time, OSPI0/1_CSn[3:0] active edge to OSPI0/1_CLK rising edge		$((0.475P^{(1)}) + (0.975M^{(2)}R^{(4)}) - 1)$	$((0.525P^{(1)}) + (1.025M^{(2)}R^{(4)}) + 1)$	ns
O11	$t_{d(CLK-CSn)}$	Delay time, OSPI0/1_CLK rising edge to OSPI0/1_CSn[3:0] inactive edge		$((0.475P^{(1)}) + (0.975N^{(3)}R^{(4)}) - 1)$	$((0.525P^{(1)}) + (1.025N^{(3)}R^{(4)}) + 1)$	ns
O12	$t_{d(CLK-D)}$	Delay time, OSPI0/1_CLK active edge to OSPI0/1_D[7:0] transition		- 2	2	ns

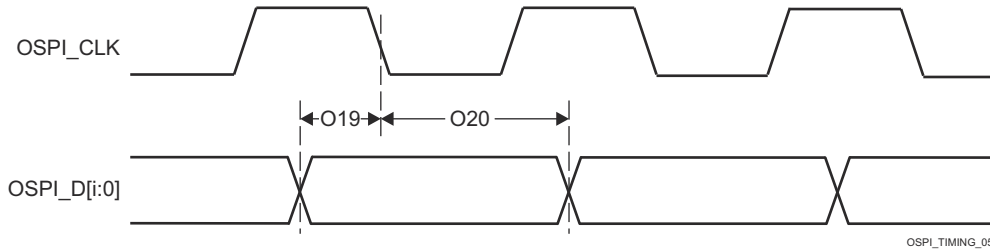
- (1) P = CLK cycle time = SCLK period in ns
- (2) M = OSPI\_DEV\_DELAY\_REG[D\_INIT\_FLD]
- (3) N = OSPI\_DEV\_DELAY\_REG[D\_AFTER\_FLD]
- (4) R = refclk cycle time in ns

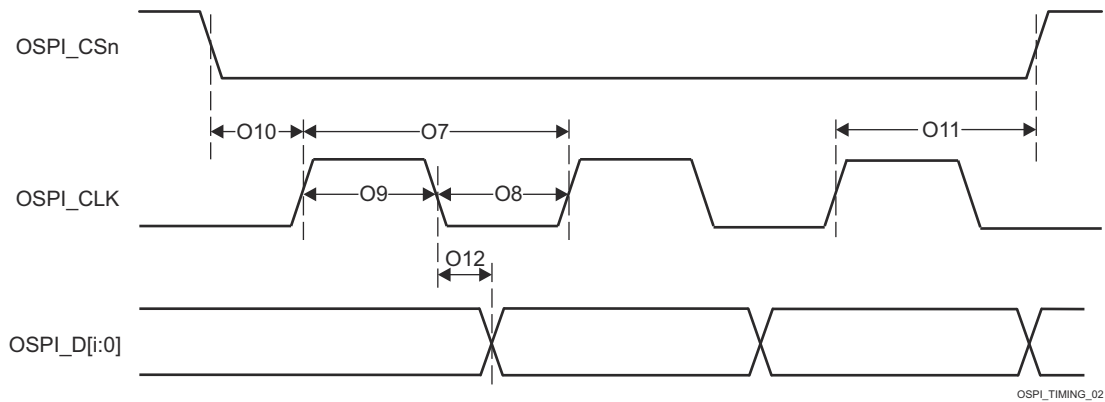

**图 7-103. OSPI0/1 Switching Characteristics - Tap SDR, No Loopback**

7.10.5.19.2.2 OSPI0 Tap DDR Timing

表 7-88, 图 7-104, 表 7-89, and 图 7-105 present timing requirements and switching characteristics for OSPI0 Tap DDR Mode.

表 7-88. OSPI0/1 Timing Requirements - Tap DDR Mode

see 图 7-104

NO.			MODE	MIN	MAX	UNIT
O13	$t_{su(D-CLK)}$	Setup time, OSPI0/1_D[7:0] valid before active OSPI0/1_CLK edge	No Loopback	(12.04 - (0.975T <sup>(1)</sup> R <sup>(2)</sup> ))		ns
O14	$t_{h(CLK-D)}$	Hold time, OSPI0/1_D[7:0] valid after active OSPI0/1_CLK edge	No Loopback	(1.84 + (0.975T <sup>(1)</sup> R <sup>(2)</sup> ))		ns

- (1) T = OSPI\_RD\_DATA\_CAPTURE\_REG[DELAY\_FLD]
- (2) R = refclk cycle time in ns



图 7-104. OSPI0/1 Timing Requirements - Tap DDR, No Loopback

表 7-89. OSPI0/1 Switching Characteristics - Tap DDR Mode

see 图 7-105

NO.	PARAMETER		MODE	MIN	MAX	UNIT
O1	$t_{c(CLK)}$	Cycle time, OSPI0/1_CLK		40		ns
O2	$t_{w(CLKL)}$	Pulse duration, OSPI0/1_CLK low		$((0.475P^{(1)}) - 0.3)$		ns
O3	$t_{w(CLKH)}$	Pulse duration, OSPI0/1_CLK high		$((0.475P^{(1)}) - 0.3)$		ns
O4	$t_{d(CSn-CLK)}$	Delay time, OSPI0/1_CSn[3:0] active edge to OSPI0/1_CLK rising edge		$((0.475P^{(1)}) + ((0.975M^{(2)}R^{(4)}) - 1)$	$((0.525P^{(1)}) + (1.025M^{(2)}R^{(4)}) + 1)$	ns
O5	$t_{d(CLK-CSn)}$	Delay time, OSPI0/1_CLK rising edge to OSPI0/1_CSn[3:0] inactive edge		$((0.475P^{(1)}) + (0.975N^{(3)}R^{(4)}) - 1)$	$((0.525P^{(1)}) + (1.025N^{(3)}R^{(4)}) + 1)$	ns
O6	$t_{d(CLK-D)}$	Delay time, OSPI0/1_CLK active edge to OSPI0/1_D[7:0] transition		$(- 17.94 + (0.975T^{(5)}R^{(4)}))$	$(- 1.56 + (1.025T^{(5)}R^{(4)}))$	ns

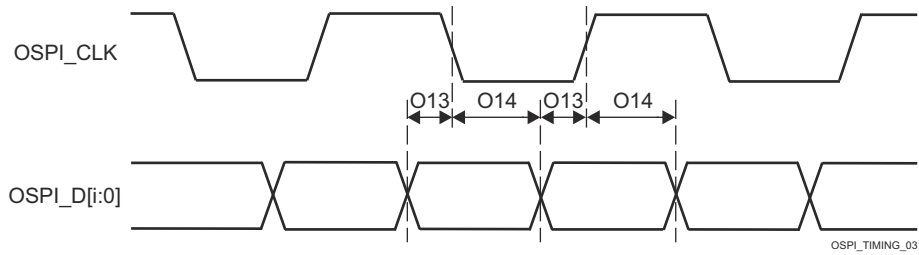
- (1) P = CLK cycle time = SCLK period in ns
- (2) M = OSPI\_DEV\_DELAY\_REG[D\_INIT\_FLD]
- (3) N = OSPI\_DEV\_DELAY\_REG[D\_AFTER\_FLD]
- (4) R = refclk cycle time in ns
- (5) T = OSPI\_RD\_DATA\_CAPTURE\_REG[DDR\_READ\_DELAY\_FLD]



图 7-105. OSPI0/1 Switching Characteristics - Tap DDR, No Loopback

7.10.5.20 PCIE

The PCI-Express Subsystem is compliant with the PCIe® Base Specification, Revision 4.0. Refer to the specification for timing details.

For more details about features and additional description information on the device Peripheral Component Interconnect Express, see the corresponding sections within [Signal Descriptions](#) and *Detailed Description*.

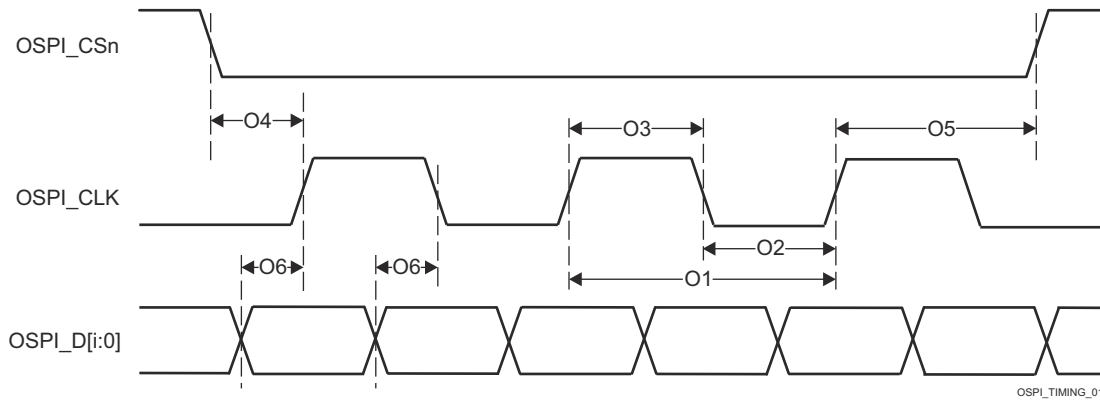
For more information, see *Peripheral Component Interconnect Express (PCIe) Subsystem* section in *Peripherals* chapter in the device TRM.

7.10.5.21 Timers

For more details about features and additional description information on the device Timers, see the corresponding sections within [Signal Descriptions](#) and *Detailed Description*.

表 7-90 represents Timers timing conditions.

表 7-90. Timers Timing Conditions

PARAMETER	DESCRIPTION	MODE	MIN	MAX	UNIT
<b>INPUT CONDITIONS</b>					
SR <sub>i</sub>	Input slew rate	CAPTURE	0.5	5	V/ns
<b>OUTPUT CONDITIONS</b>					

表 7-90. Timers Timing Conditions (continued)

PARAMETER	DESCRIPTION	MODE	MIN	MAX	UNIT
C <sub>L</sub>	Output load capacitance	PWM	2	10	pF

节 7.10.5.21.1, 节 7.10.5.21.2 和 图 7-106 present timings and switching characteristics of the Timers.

#### 7.10.5.21.1 Timing Requirements for Timers

NO.	PARAMETER	DESCRIPTION	MODE	MIN	MAX	UNIT
T1	t <sub>w(TINPH)</sub>	Pulse duration, high	CAPTURE	2.5 + 4P <sup>(1)</sup>		ns
T2	t <sub>w(TINPL)</sub>	Pulse duration, low	CAPTURE	2.5 + 4P <sup>(1)</sup>		ns

(1) P = functional clock period in ns.

#### 7.10.5.21.2 Switching Characteristics for Timers

NO.	PARAMETER	DESCRIPTION	MODE	MIN	MAX	UNIT
T3	t <sub>w(TOUTH)</sub>	Pulse duration, high	PWM	-2.5 + 4P <sup>(1)</sup>		ns
T4	t <sub>w(TOURL)</sub>	Pulse duration, low	PWM	-2.5 + 4P <sup>(1)</sup>		ns

(1) P = functional clock period in ns.



图 7-106. Timer Timing

For more information, see *Timers* section in *Peripherals* chapter in the device TRM.

#### 7.10.5.22 UART

For more details about features and additional description information on the device Universal Asynchronous Receiver Transmitter, see the corresponding sections within , [Signal Descriptions](#) and *Detailed Description*.

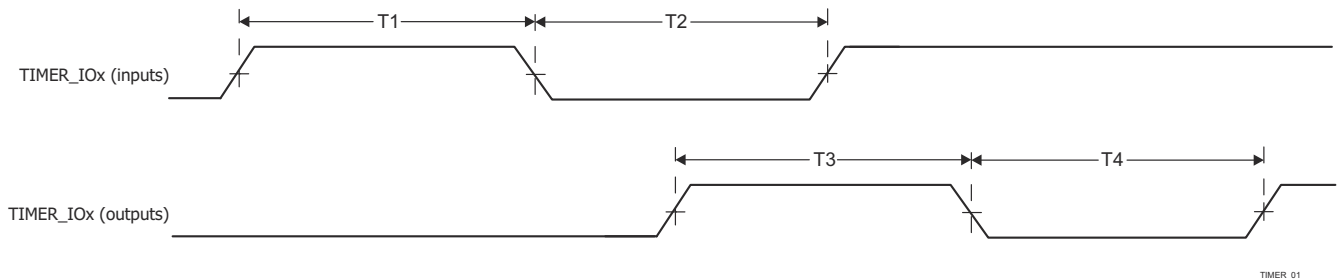
表 7-91 represents UART timing conditions.

表 7-91. UART Timing Conditions

PARAMETER	DESCRIPTION	MIN	MAX	UNIT
<b>INPUT CONDITIONS</b>				
SR <sub>i</sub>	Input slew rate	0.5	5	V/ns
<b>OUTPUT CONDITIONS</b>				
C <sub>L</sub>	Output load capacitance	1	30 <sup>(1)</sup>	pF

(1) This value represents an absolute maximum load capacitance. As the UART baud rate increases, it may be necessary to reduce the load capacitance to a value less than this maximum limit to provide enough timing margin for the attached device. The output rise/fall times increase as capacitive load increases, which decreases the time data is valid for the receiver of the attached devices. Therefore, it is important to understand the minimum data valid time required by the attached device at the operating baud rate. Then use the device IBIS models to verify the actual load capacitance on the UART signals does not increase the rise/fall times beyond the point where the minimum data valid time of the attached device is violated.

节 7.10.5.22.1, 节 7.10.5.22.2, and 图 7-107 present timing requirements and switching characteristics for UART interface.

**7.10.5.22.1 Timing Requirements for UART**

NO.	PARAMETER	DESCRIPTION	MODE	MIN	MAX	UNIT
4	$t_{w(rx d)}$	Pulse width, receive data bit, high or low		0.95U <sup>(1)</sup> (2)	1.05U <sup>(1)</sup> (2)	ns
5	$t_{w(rx dS)}$	Pulse width, receive start bit, low		0.95U <sup>(1)</sup> (2)		ns

(1) U = UART baud time = 1/Programmed baud rate

(2) This value defines the data valid time, where the input voltage is required to be above V<sub>IH</sub> or below V<sub>IL</sub>.

**7.10.5.22.2 UART Switching Characteristics**

NO.	PARAMETER	DESCRIPTION	MIN	MAX	UNIT
	$f_{(baud)}$	Maximum programmable baud rate		12	Mbps
2	$t_{w(TX)}$	Pulse width, transmit data bit, high or low	U - 2 <sup>(1)</sup>	U + 2 <sup>(1)</sup>	ns
3	$t_{w(RTS)}$	Pulse width, transmit start bit, high or low	U - 2 <sup>(1)</sup>		ns

(1) U = UART baud time = 1/Programmed baud rate



图 7-107. UART Timing

For more information, see *Universal Asynchronous Receiver/Transmitter (UART)* section in *Peripherals* chapter in the device TRM.

**7.10.5.23 USB**

The USB 2.0 subsystem is compliant with the Universal Serial Bus (USB) Specification, revision 2.0. Refer to the specification for timing details.

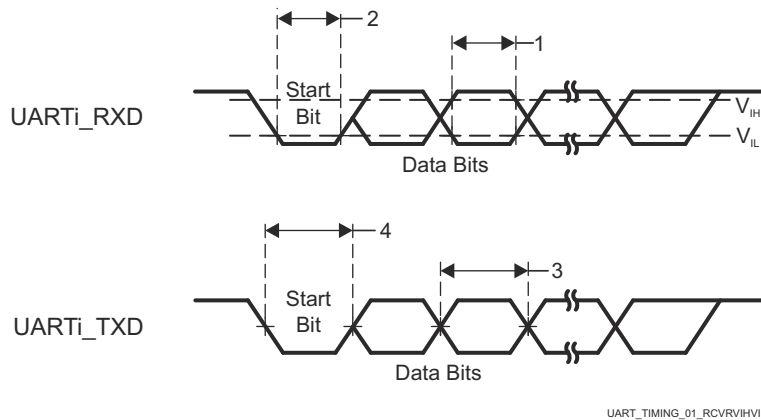
The USB 3.1 GEN1 Dual-Role Device Subsystem is compliant with the Universal Serial Bus (USB) 3.1 Specification, revision 1.0. Refer to the specification for timing details.

For more details about features and additional description information on the device Universal Serial Bus Subsystem (USB), see the corresponding sections within [Signal Descriptions](#) and [Detailed Description](#).

**7.10.6 Emulation and Debug**

**7.10.6.1 Trace**

表 7-92. Trace Timing Conditions

PARAMETER	MIN	MAX	UNIT
<b>OUTPUT CONDITIONS</b>			
C <sub>L</sub>	Output load capacitance	2	5 pF

表 7-92. Trace Timing Conditions (continued)

PARAMETER		MIN	MAX	UNIT
<b>PCB CONNECTIVITY REQUIREMENTS</b>				
$t_d$ (Trace Mismatch)	Propagation delay mismatch across all traces		200	ps

表 7-93 和 图 7-108 假设测试在推荐的运行条件和电气特性条件下进行。

表 7-93. Trace Switching Characteristics

NO.	PARAMETER		MIN	MAX	UNIT
<b>1.8 V Mode</b>					
DBTR1	$t_c$ (TRC_CLK)	Cycle time, TRC_CLK	6.50		ns
DBTR2	$t_w$ (TRC_CLKH)	Pulse width, TRC_CLK high	2.50		ns
DBTR3	$t_w$ (TRC_CLKL)	Pulse width, TRC_CLK low	2.50		ns
DBTR4	$t_{osu}$ (TRC_DATAV-TRC_CLK)	Output setup time, TRC_DATA valid to TRC_CLK edge	0.81		ns
DBTR5	$t_{oh}$ (TRC_CLK-TRC_DATAI)	Output hold time, TRC_CLK edge to TRC_DATA invalid	0.81		ns
DBTR6	$t_{osu}$ (TRC_CTLV-TRC_CLK)	Output setup time, TRC_CTL valid to TRC_CLK edge	0.81		ns
DBTR7	$t_{oh}$ (TRC_CLK-TRC_CTLI)	Output hold time, TRC_CLK edge to TRC_CTL invalid	0.81		ns
<b>3.3 V Mode</b>					
DBTR1	$t_c$ (TRC_CLK)	Cycle time, TRC_CLK	9.75		ns
DBTR2	$t_w$ (TRC_CLKH)	Pulse width, TRC_CLK high	4.13		ns
DBTR3	$t_w$ (TRC_CLKL)	Pulse width, TRC_CLK low	4.13		ns
DBTR4	$t_{osu}$ (TRC_DATAV-TRC_CLK)	Output setup time, TRC_DATA valid to TRC_CLK edge	1.22		ns
DBTR5	$t_{oh}$ (TRC_CLK-TRC_DATAI)	Output hold time, TRC_CLK edge to TRC_DATA invalid	1.22		ns
DBTR6	$t_{osu}$ (TRC_CTLV-TRC_CLK)	Output setup time, TRC_CTL valid to TRC_CLK edge	1.22		ns
DBTR7	$t_{oh}$ (TRC_CLK-TRC_CTLI)	Output hold time, TRC_CLK edge to TRC_CTL invalid	1.22		ns

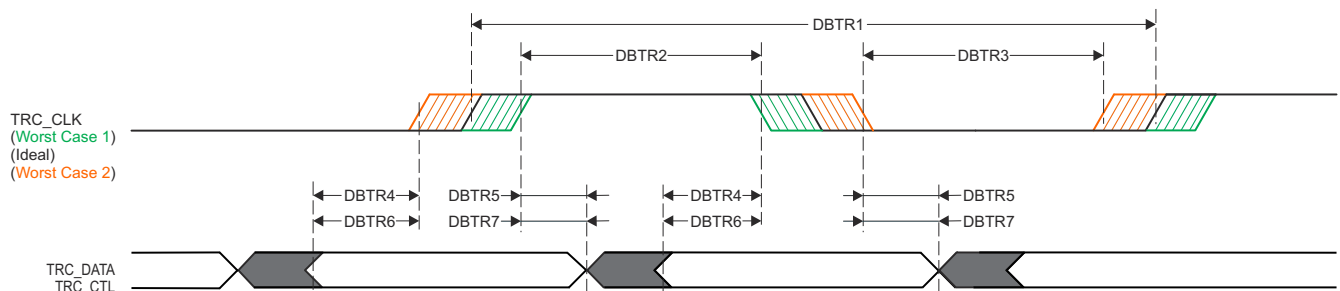

SPRSP08\_Debug\_01

图 7-108. Trace Switching Characteristics

### 7.10.6.2 JTAG

For more details about features and additional description information on the device IEEE 1149.1 Standard - Test - Access Port, see the corresponding sections within [Signal Descriptions](#) and [Detailed Description](#).

## 备注

The JTAG signals are split across two IO power domains on the device. Timings parameters defined in this section only apply when the two IO power domains are operating at the same voltage and level-shifters are not inserted into the signal path. Values for the following timing parameters are not defined when operating the two IO power domains at different voltages since propagation delay through the device IO buffers differ when some are operating at 1.8 V while others are operating at 3.3 V. This effectively reduces timing margin beyond the values defined in this section. The JTAG interface is still expected to function when the two IO power domains are operated at different voltages, assuming the system designer has implemented appropriate level-shifters and the operating frequency is reduced to accommodate additional delay inserted by the level-shifters and IO buffers operating at different voltages.

表 7-94. JTAG Timing Conditions

PARAMETER		MIN	MAX	UNIT
<b>Input Conditions</b>				
SR <sub>i</sub>	Input slew rate	0.50	2.00	V/ns
<b>Output Conditions</b>				
C <sub>L</sub>	Output load capacitance	5	15	pF
<b>PCB CONNECTIVITY REQUIREMENTS</b>				
t <sub>d</sub> (Trace Delay)	Propagation delay of each trace	83.5	1000 <sup>(1)</sup>	ps
t <sub>d</sub> (Trace Mismatch Delay)	Propagation delay mismatch across all traces		100	ps

- (1) Maximum propagation delay associated with the JTAG signal traces has a significant impact on maximum TCK operating frequency. It may be possible to increase the trace delay beyond this value, but the operating frequency of TCK must be reduced to account for the additional trace delay.

## 7.10.6.2.1 JTAG Electrical Data and Timing

节 7.10.6.2.1.1, 节 7.10.6.2.1.2, and 图 7-109 assume testing over the recommended operating conditions and electrical characteristic conditions.

## 7.10.6.2.1.1 JTAG Timing Requirements

See 图 7-109

NO.			MIN	MAX	UNIT
J1	t <sub>c</sub> (TCK)	Cycle time minimum, TCK	46.5 <sup>(1)</sup>		ns
J2	t <sub>w</sub> (TCKH)	Pulse width minimum, TCK high	18.6 <sup>(2)</sup>		ns
J3	t <sub>w</sub> (TCKL)	Pulse width minimum, TCK low	18.6 <sup>(2)</sup>		ns
J4	t <sub>su</sub> (TDI-TCK)	Input setup time minimum, TDI valid to TCK high	4.5		ns
	t <sub>su</sub> (TMS-TCK)	Input setup time minimum, TMS valid to TCK high	4.5		ns
J5	t <sub>h</sub> (TCK-TDI)	Input hold time minimum, TDI valid from TCK high	2		ns
	t <sub>h</sub> (TCK-TMS)	Input hold time minimum, TMS valid from TCK high	2		ns

- (1) The maximum TCK operating frequency assumes the following timing requirements and switching characteristics for the attached debugger. The operating frequency of TCK must be reduced to provide appropriate timing margin if the debugger exceeds any of these assumptions.

- Minimum TDO setup time of 4.6 ns relative to the rising edge of TCK
- TDI and TMS output delay in the range of - 16.5 ns to 14.0 ns relative to the falling edge of TCK

- (2) P = TCK cycle time in ns

## 7.10.6.2.1.2 JTAG Switching Characteristics

See 图 7-109

NO.	PARAMETER	MIN	MAX	UNIT
J6	t <sub>d</sub> (TCKL-TDOI)	Delay time minimum, TCK low to TDO invalid	0	ns

See [图 7-109](#)

NO.	PARAMETER		MIN	MAX	UNIT
J7	$t_d(\text{TCKL-TDOV})$	Delay time maximum, TCK low to TDO valid		12	ns

- The JTAG signals are split across two IO power domains on the device. Timings parameters defined in this table only apply when the two IO power domains are operating at the same voltage. Values for these timing parameters are not defined when operating the two IO power domains at different voltages since propagation delay through the device IO buffers differ when some are operating at 1.8V while others are operating at 3.3V. This effectively reduces timing margin beyond the values defined in this table. The JTAG interface is still expected to function when the two IO power domains are operated at different voltages, assuming the system designer has implemented appropriate level shifters and the operating frequency is reduced to accommodate additional delay inserted by the level-shifters and IO buffers operating at different voltages.

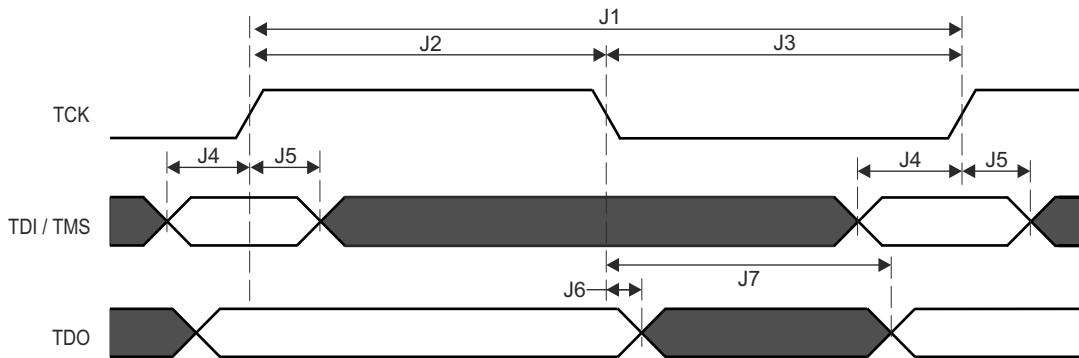

**图 7-109. JTAG Timing Requirements and Switching Characteristics**

## 8 Applications, Implementation, and Layout

---

### 备注

Information in the following applications sections is not part of the TI component specification, and TI does not warrant its accuracy or completeness. TI's customers are responsible for determining suitability of components for their purposes. Customers should validate and test design implementation to confirm system functionality.

---

### 8.1 Device Connection and Layout Fundamentals

#### 8.1.1 Power Supply Decoupling and Bulk Capacitors

##### 8.1.1.1 Power Distribution Network Implementation Guidance

The [Sitara Processor Power Distribution Networks: Implementation and Analysis](#) provides guidance for successful implementation of the power distribution network. This includes PCB stackup guidance as well as guidance for optimizing the selection and placement of the decoupling capacitors. TI supports *only* designs that follow the board design guidelines contained in the application report.

#### 8.1.2 External Oscillator

For more information about External Oscillators, see [Clock Specifications](#).

#### 8.1.3 JTAG and EMU

Texas Instruments supports a variety of eXtended Development System (XDS) JTAG controllers with various debug capabilities beyond only JTAG support. A summary of this information is available in the [XDS Target Connection Guide](#).

For more recommendations on EMU routing, see [Emulation and Trace Headers Technical Reference Manual](#)

#### 8.1.4 Reset

The device incorporates four external reset pins (MCU\_PORz, MCU\_RESETz, PORz, and RESET\_REQz) and two reset status pins (MCU\_RESETSTATz and RESETSTATz). These pins can be driven by an external power good circuitry or Power Management IC (PMIC). MCU\_PORz and Main PORz pins should be held active low during the entire power-up phase, and until all power supplies as well as the HFOSC0 clock are stable.

All MCU domain resets act as master resets to the whole device, whereas Main domain resets only reset Main domain (MCU domain is reset isolated from all Main domain resets).

#### 8.1.5 Unused Pins

For more information about Unused Pins, see [Pin Connectivity Requirements](#)

#### 8.1.6 Hardware Design Guide for Jacinto™ 7 Devices

The Hardware Design Guide for Jacinto™ 7 Devices document describes hardware system design considerations for the Jacinto™ 7 family of processors. This design guide is intended to be used as an aid during the development of application hardware.

### 8.2 Peripheral- and Interface-Specific Design Information

#### 8.2.1 LPDDR4 Board Design and Layout Guidelines

The goal of the [Jacinto 7 DDR Board Design and Layout Guidelines](#) is to make the LPDDR4 system implementation straightforward for all designers. Requirements have been distilled down to a set of layout and routing rules that allow designers to successfully implement a robust design for the topologies that TI supports. TI only supports board designs using LPDDR4 memories that follow the guidelines in this document.

#### 8.2.2 OSPI and QSPI Board Design and Layout Guidelines

The following section details the routing guidelines that must be observed when routing the OSPI and QSPI interfaces.

### 8.2.2.1 No Loopback and Internal Pad Loopback

- The MCU\_OSPI[x]\_CLK output signal must be connected to the CLK pin of the flash device
- The signal propagation delay from the MCU\_OSPI[x]\_CLK signal to the flash device must be  $< 450$  ps ( $\sim 7$ cm as stripline or  $\sim 8$ cm as microstrip)
- $50\ \Omega$  PCB routing is recommended along with series terminations, as shown in 图 8-1
- Propagation delays and matching:
  - A to B  $< 450$  ps
  - Matching skew:  $< 60$  ps

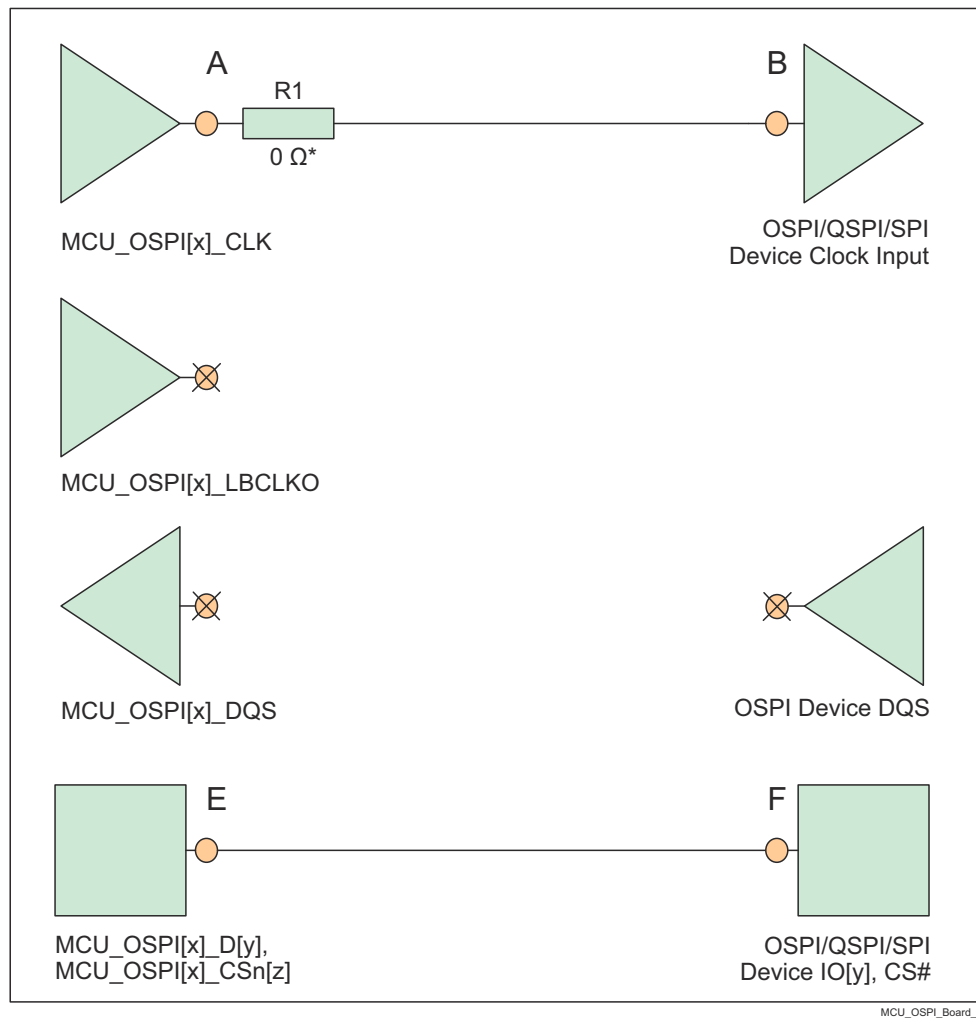

\*  $0\ \Omega$  resistor (R1), located as close as possible to the MCU\_OSPI[x]\_CLK pin, is placeholder for fine tuning, if needed.

图 8-1. OSPI Interface High Level Schematic

### 8.2.2.2 External Board Loopback

- The MCU\_OSPI[x]\_CLK output signal must be connected to the CLK pin of the flash device
- The MCU\_OSPI[x]\_LBCLKO output signal must be looped back into the MCU\_OSPI[x]\_DQS input
- The signal propagation delay from the MCU\_OSPI[x]\_CLK pin to the flash device CLK input pin (A to B) should be approximately equal to half of the signal propagation delay from the MCU\_OSPI[x]\_LBCLKO pin to the MCU\_OSPI[x]\_DQS pin ((C to D)/2). See the note below.

- The signal propagation delay from the MCU\_OSPI[x]\_CLK pin to the flash device CLK input pin (A to B) must be approximately equal to the signal propagation delay of the control and data signals between the flash device and the SoC device (E to F, or F to E)
- 50 Ω PCB routing is recommended along with series terminations, as shown in 图 8-2
- Propagation delays and matching:
  - A to B = E to F = (C to D) / 2
  - Matching skew: < 60 ps

备注

The OSPI Board Loopback Hold time requirement (described in OSPI) is larger than the Hold time provided by a typical flash device. Therefore, the length of MCU\_OSPI[x]\_LBCLKO pin to the MCU\_OSPI[x]\_DQS pin (C to D) can be shortened to compensate.

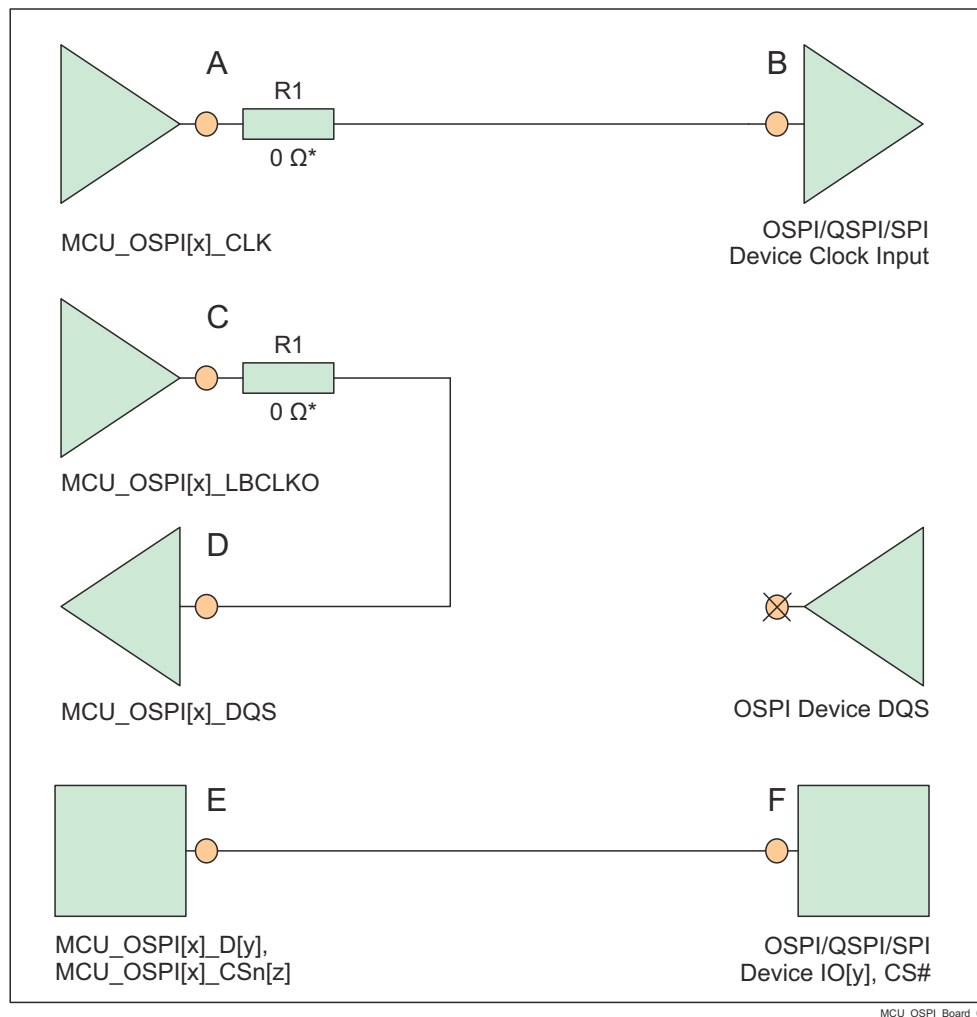

\* 0 Ω resistor (R1), located as close as possible to the MCU\_OSPI[x]\_CLK and MCU\_OSPI[x]\_LBCLKO pins, is a placeholder for fine tuning, if needed.

图 8-2. OSPI Interface High Level Schematic

8.2.2.3 DQS (only available in Octal Flash devices)

- The MCU\_OSPI[x]\_CLK output signal must be connected to the CLK pin of the flash device
- The DQS pin of the flash devices must be connected to MCU\_OSPI[x]\_DQS signal

- The signal propagation delay from the MCU\_OSPI[x]\_CLK pin to the flash device CLK input pin (A to B) should be approximately equal to the signal propagation delay from the MCU\_OSPI[x]\_DQS pin to the DQS output pin (C to D)
- 50  $\Omega$  PCB routing is recommended along with series terminations, as shown in 图 8-3
- Propagation delays and matching:
  - A to B = C to D
  - Matching skew: < 60 ps

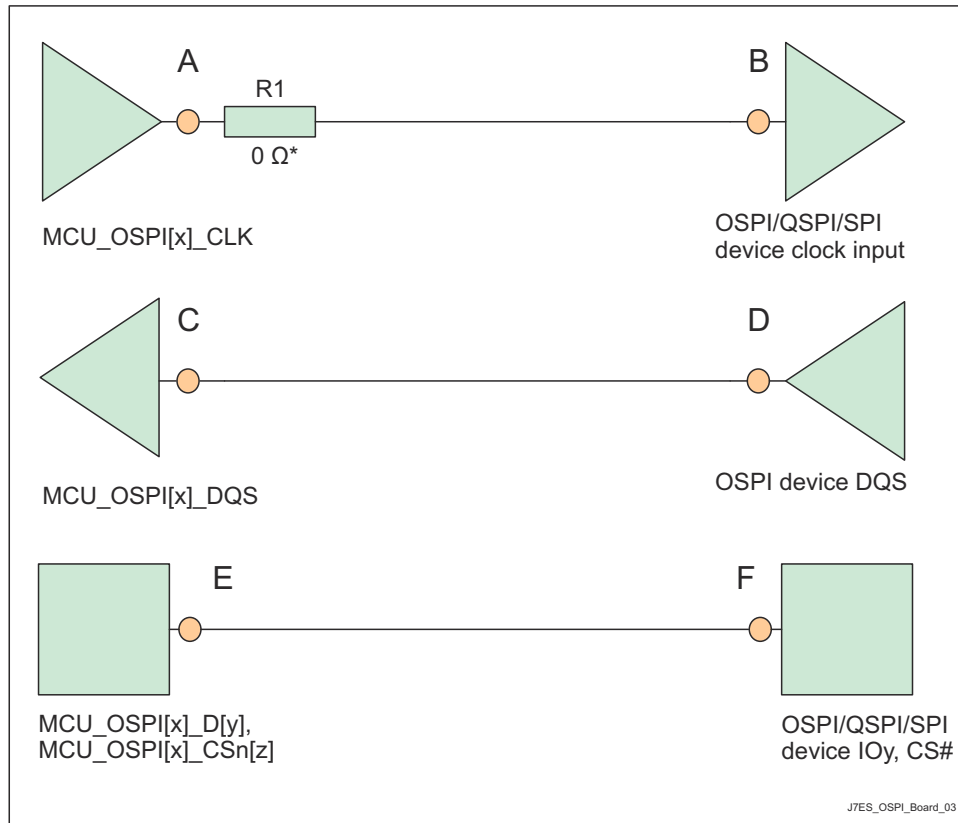

\* 0  $\Omega$  resistor (R1), located as close as possible to the MCU\_OSPI[x]\_CLK pin, is a placeholder for fine tuning, if needed.

图 8-3. OSPI Interface High Level Schematic

### 8.2.3 USB VBUS Design Guidelines

The USB 3.1 specification allows the VBUS voltage to be as high as 5.5 V for normal operation, and as high as 20 V when the Power Delivery addendum is supported. Some automotive applications require a max voltage to be 30 V.

The device requires the VBUS signal voltage be scaled down using an external resistor divider (as shown in the 图 8-4), which limits the voltage applied to the actual device pin (USB0\_VBUS). The tolerance of these external resistors should be equal to or less than 1%, and the leakage current of zener diode at 5 V should be less than 100 nA.<sup>(1)</sup>



图 8-4. USB VBUS Detect Voltage Divider / Clamp Circuit

The USB0\_VBUS pin can be considered to be fail-safe because the external circuit in 图 8-4 limits the input current to the actual device pin in a case where VBUS is applied while the device is powered off.

### 8.2.4 System Power Supply Monitor Design Guidelines using VMON/POK

The VMON1\_ER\_VSYS pin provides a way to monitor a system power supply. This system power supply is typically a single pre-regulated power source for the entire system. This supply is monitored by comparing the output of an external voltage divider circuit sourced by this supply with an internal voltage reference, with a power fail event being triggered when the voltage applied to VMON1\_ER\_VSYS drops below the internal reference voltage. The actual system power supply voltage trip point is determined by the system designer when selecting component values used to implement the external resistor voltage divider circuit. When designing the resistor divider circuit it is important to understand various factors which contribute to variability in the system power supply monitor trip point. The first thing to consider is the initial accuracy of the VMON1\_ER\_VSYS input threshold which has a nominal value of 0.45 V, with a variation of  $\pm 3\%$ . Precision 1% resistors with similar thermal coefficient are recommended for implementing the resistor voltage divider. This minimizes variability contributed by resistor value tolerances. Input leakage current associated with VMON1\_ER\_VSYS must also be considered since any current flowing into the pin creates a loading error on the voltage divider output. The VMON1\_ER\_VSYS input leakage current may be in the range of 10 nA to 2.5  $\mu$ A when applying 0.45 V.

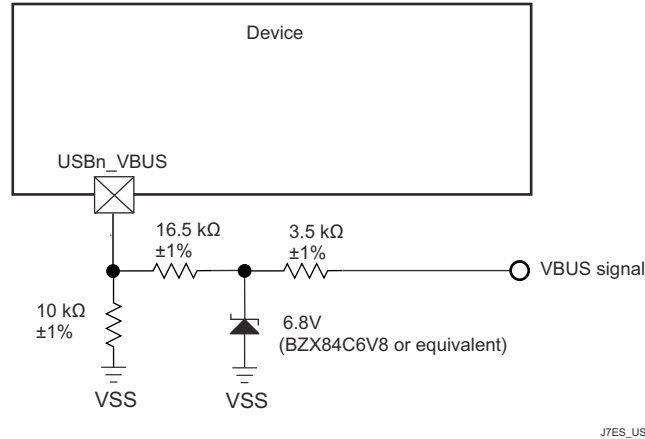
#### 备注

The resistor voltage divider shall be designed such that its output voltage never exceeds the maximum value defined in [Recommended Operating Conditions](#) during normal operating conditions.

图 8-5 presents an example, where the system power supply is nominally 5 V and the maximum trigger threshold is 5 V - 10%, or 4.5 V.

For this example, it is important to understand which variables effect the maximum trigger threshold when selecting resistor values. It is obvious a device which has a VMON1\_ER\_VSYS input threshold of 0.45 V + 3% needs to be considered when trying to design a voltage divider that doesn't trip until the system supply drops 10%. The effect of resistor tolerance and input leakage also needs to be considered, but how these contributions effect the maximum trigger point may not be obvious. When selecting component values which produce a maximum trigger voltage, the system designer must consider a condition where the value of R1 is 1% low and the value of R2 is 1% high combined with a condition where input leakage current for the VMON1\_ER\_VSYS pin is 2.5  $\mu$ A. When implementing a resistor divider where R1 = 4.81 K $\Omega$  and R2 = 40.2 K $\Omega$ , the result is a maximum trigger threshold of 4.523 V.

Once component values have been selected to satisfy the maximum trigger voltage as described above, the system designer can determine the minimum trigger voltage by calculating the applied voltage that produces an output voltage of 0.45 V - 3% when the value of R1 is 1% high and the value of R2 is 1% low, and the input

leakage current is 10 nA, or zero. Using an input leakage of zero with the resistor values given above, the result is a minimum trigger threshold of 4.008 V.

This example demonstrates a system power supply voltage trip point that ranges from 4.008 V to 4.523 V. Approximately 250 mV of this range is introduced by VMON1\_ER\_VSYS input threshold accuracy of  $\pm 3\%$ , approximately 150 mV of this range is introduced by resistor tolerance of  $\pm 1\%$ , and approximately 100 mV of this range is introduced by loading error when VMON1\_ER\_VSYS input leakage current is 2.5  $\mu$ A.

The resistor values selected in this example produces approximately 100  $\mu$ A of bias current through the resistor divider when the system supply is 4.5 V. The 100 mV of loading error mentioned above could be reduced to about 10 mV by increasing the bias current through the resistor divider to approximately 1 mA. So resistor divider bias current vs loading error is something the system designer needs to consider when selecting component values.

The system designer should also consider implementing a noise filter on the voltage divider output since VMON1\_ER\_VSYS has minimum hysteresis and a high-bandwidth response to transients. This could be done by installing a capacitor across R1 as shown in [图 8-5](#). However, the system designer must determine the response time of this filter based on system supply noise and expected response to transient events.

[图 8-5](#) presents an example, when the system power supply voltage is nominally 5 V and the desired trigger threshold is -10% or 4.5 V.

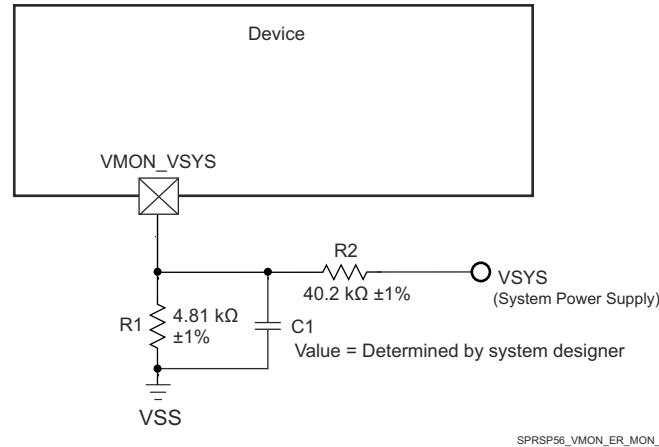

**图 8-5. System Supply Monitor Voltage Divider Circuit**

The **VMON2\_IR\_VCPU** pin provides a way to monitor VDD\_CPU power supply. Must be externally connected as close as possible to VDD\_CPU pin on the board. SoCs that have a **VMON6\_IR\_VEXT0P8** can optionally monitor other domains such as VDD\_CORE or VDD\_MCU. Similarly, those signals should be as close as possible to VDD\_CORE or VDD\_MCU pin on the board.

The **VMON3\_IR\_VEXT1P8** and **VMON4\_IR\_VEXT1P8** pins provide a way to monitor an external 1.8-V power supply. The **VMON5\_IR\_VEXT3P3** pin provides a way to monitor an external 3.3-V power supply. An internal resistor divider with software control is implemented inside the SoC. Software can program the internal resistor divider to create appropriate under voltage and over voltage interrupts. These pins should not be sourced from an external resistor divider. If the monitored voltage requires adjustment, be sure to buffer the divided voltage prior connecting to monitor pin.

### 8.2.5 High Speed Differential Signal Routing Guidance

The [High Speed Interface Layout Guidelines](#) provides guidance for successful routing of the high speed differential signals. This includes PCB stackup and materials guidance as well as routing skew, length and spacing limits. TI supports *only* designs that follow the board design guidelines contained in the application report.

## 8.2.6 Thermal Solution Guidance

The [Thermal Design Guide for DSP and ARM Application Processors](#) provides guidance for successful implementation of a thermal solution for system designs containing this device. This document provides background information on common terms and methods related to thermal solutions. TI only supports designs that follow system design guidelines contained in the application report.

## 9 Device and Documentation Support

TI offers an extensive line of development tools. Tools and software to evaluate the performance of the device, generate code, and develop solutions are listed below.

### 9.1 Device Nomenclature

To designate the stages in the product development cycle, TI assigns prefixes to the part numbers of all microprocessors (MPUs) and support tools. Each device has one of three prefixes: X, P, or null (no prefix). Texas Instruments recommends two of three possible prefix designators for its support tools: TMDX and TMDS. These prefixes represent evolutionary stages of product development from engineering prototypes (TMDX) through fully qualified production devices and tools (TMDS).

Device development evolutionary flow:

- X** Experimental device that is not necessarily representative of the final device's electrical specifications and may not use production assembly flow.
- P** Prototype device that is not necessarily the final silicon die and may not necessarily meet final electrical specifications.
- null** Production version of the silicon die that is fully qualified.

Support tool development evolutionary flow:

- TMDX** Development-support product that has not yet completed Texas Instruments internal qualification testing.
- TMDS** Fully-qualified development-support product.

X and P devices and TMDX development-support tools are shipped against the following disclaimer:

"Developmental product is intended for internal evaluation purposes."

Production devices and TMDS development-support tools have been characterized fully, and the quality and reliability of the device have been demonstrated fully. TI's standard warranty applies.

Predictions show that prototype devices (X or P) have a greater failure rate than the standard production devices. Texas Instruments recommends that these devices not be used in any production system because their expected end-use failure rate still is undefined. Only qualified production devices are to be used.

For orderable part numbers, see the Package Option Addendum of this document, the TI website ([ti.com](http://ti.com)), or contact your TI sales representative.

### 9.1.1 Standard Package Symbolization

#### 备注

Some devices may have a cosmetic circular marking visible on the top of the device package which results from the production test process. In addition, some devices may also show a color variation in the package substrate which results from the substrate manufacturer. These differences are cosmetic only with no reliability impact.



图 9-1. Printed Device Reference

### 9.1.2 Device Naming Convention

备注

BLANK in the symbol or part number is collapsed so there are no gaps between characters.

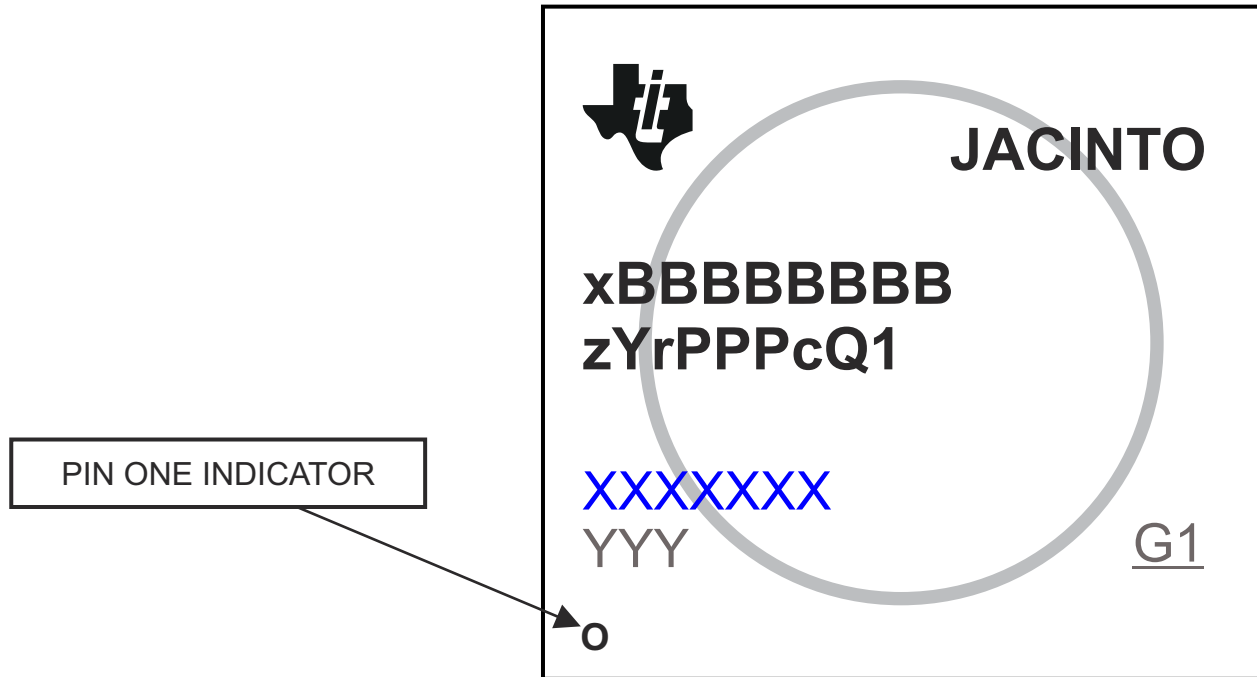
**表 9-1. Nomenclature Description**

FIELD PARAMETER	FIELD DESCRIPTION	VALUES		DESCRIPTION
		MARKING	ORDERABLE	
x	Device evolution stage <sup>(1)</sup>	X		Prototype
		P		Preproduction (production test flow, no reliability data)
		BLANK		Production
BBBBBB <sup>(2)</sup>	Base production part number	J721S2 <sup>(2)</sup>		Preproduction superset device
		TDA4VE88		See 节 5, <i>Device Comparison</i>
		TDA4AL88		
		TDA4VL21		
z	Device Speed	T		See 表 7-1, <i>Speed Grade Maximum Frequency</i> .
		N		
		H		
		OTHER		Alternate speed grade
Y	Device type	G		General purpose
		C		General purpose, R5F Lockstep capable
		0		High Security <sup>(3)</sup> capable
		5		High Security <sup>(3)</sup> capable, R5F Lockstep capable
		R		High Security Prime <sup>(3)</sup> capable, R5F Lockstep capable
		D		High Security <sup>(3)</sup> capable, R5F Lockstep capable, Customer Dev Keys. Only available on preproduction J721S2 devices.
		P		High Security Prime <sup>(3)</sup> capable, R5F Lockstep capable, Customer Dev Keys. Only available on preproduction J721S2 devices.
r	Device revision	A or BLANK		SR 1.0
PPP	Package designator	ALZ		ALZ FCBGA-N770 (23 mm x 23 mm) Package
c	Carrier designator	N/A	BLANK	Tray
		N/A	R	Tape and Reel
Q1	Automotive Designator	BLANK		Not automotive qualified. Supports T <sub>J</sub> = - 40°C to 105°C
		Q1		Meets AEC-Q100 qualification requirements, with exceptions as specified in this data sheet. Supports T <sub>J</sub> = - 40°C to 125°C
XXXXXX	Lot Trace Code	As Marked	N/A	Lot Trace Code (LTC)
YYY	Production Code	As Marked	N/A	Production Code, for TI use only
ZZZ	Production Code	As Marked	N/A	Production Code, for TI use only
O	Pin One	As Marked	N/A	Pin one designator
G1	ECAT	As Marked	N/A	ECAT—Green package designator

- (1) To designate the stages in the product development cycle, TI assigns prefixes to the part numbers. These prefixes represent evolutionary stages of product development from engineering prototypes through fully qualified production devices. Prototype devices are shipped against the following disclaimer:  
 “This product is still in development and is intended for internal evaluation purposes.”  
 Notwithstanding any provision to the contrary, TI makes no warranty expressed, implied, or statutory, including any implied warranty of merchantability of fitness for a specific purpose, of this device.

- (2) J721S2 is the base part number for the preproduction superset device. Software should constrain the features used to match the intended production device.
- (3) For HS device support, TI recommends the 0, 5, or D device types. The R and P (HS “prime”) device types are not recommended for most applications, as they require extra steps in the manufacturing process and have a higher cost.

## 9.2 Tools and Software

The following products support development for TDA4VM platforms:

### Development Tools

**Code Composer Studio™ Integrated Development Environment** Code Composer Studio (CCS) Integrated Development Environment (IDE) is a development environment that supports TI's Microcontroller and Embedded Processors portfolio. Code Composer Studio comprises a suite of tools used to develop and debug embedded applications. It includes an optimizing C/C++ compiler, source code editor, project build environment, debugger, profiler, and many other features. The intuitive IDE provides a single user interface taking you through each step of the application development flow. Familiar tools and interfaces allow users to get started faster than ever before. Code Composer Studio combines the advantages of the Eclipse software framework with advanced embedded debug capabilities from TI resulting in a compelling feature-rich development environment for embedded developers.

**SYSCONFIG Tool** System Configuration Tool To help simplify configuration challenges and accelerate software development, TI created SysConfig, an intuitive and comprehensive collection of graphical utilities for configuring pins, peripherals, radios, subsystems, and other components. SysConfig helps you manage, expose, and resolve conflicts visually so that you have more time to create differentiated applications. The SysConfig tool is integrated in Code Composer Studio™ (CCS) IDE, as a standalone installer, or can be used via the [dev.ti.com](http://dev.ti.com) cloud tools portal.

For a complete listing of development-support tools for the processor platform, visit the Texas Instruments website at [ti.com](http://ti.com). For information on pricing and availability, contact the nearest TI field sales office or authorized distributor.

### 9.3 Documentation Support

要接收文档更新通知，请导航至 [ti.com](http://ti.com) 上的器件产品文件夹。点击 [订阅更新](#) 进行注册，即可每周接收产品信息更改摘要。有关更改的详细信息，请查看任何已修订文档中包含的修订历史记录。

The following documents describe the TDA4x devices.

#### Technical Reference Manual

**TDA4AL, TDA4VL, TDA4VE Technical Reference Manual** Details the integration, the environment, the functional description, and the programming models for each peripheral and subsystem in the TDA4VM family of devices.

#### Errata

**J721S2, TDA4VE, TDA4AL, TDA4VL Processor Silicon Revision 1.0, Silicon Errata** Describes the known exceptions to the functional specifications for the device.

### 9.4 Trademarks

eMMC™ is a trademark of MultiMediaCard Association.

Jacinto™, Code Composer Studio™, and TI E2E™ are trademarks of Texas Instruments.

Arm® and Cortex® are registered trademarks of Arm Limited (or its subsidiaries) in the US and/or elsewhere.

PCI-Express® is a registered trademark of PCI-SIG.

安全数字® is a registered trademark of SD Card Association.

所有商标均为其各自所有者的财产。

### 9.5 支持资源

TI E2E™ 支持论坛是工程师的重要参考资料，可直接从专家获得快速、经过验证的解答和设计帮助。搜索现有解答或提出自己的问题可获得所需的快速设计帮助。

链接的内容由各个贡献者“按原样”提供。这些内容并不构成 TI 技术规范，并且不一定反映 TI 的观点；请参阅 TI 的《使用条款》。

## 9.6 静电放电警告



静电放电 (ESD) 会损坏这个集成电路。德州仪器 (TI) 建议通过适当的预防措施处理所有集成电路。如果不遵守正确的处理和安装程序，可能会损坏集成电路。

ESD 的损坏小至导致微小的性能降级，大至整个器件故障。精密的集成电路可能更容易受到损坏，这是因为非常细微的参数更改都可能会导致器件与其发布的规格不相符。

## 9.7 术语表

### TI 术语表

本术语表列出并解释了术语、首字母缩略词和定义。

## 10 Mechanical, Packaging, and Orderable Information

### 10.1 Packaging Information

The following pages include mechanical, packaging, and orderable information. This information is the most current data available for the designated devices. This data is subject to change without notice and revision of this document. For browser-based versions of this data sheet, refer to the left-hand navigation.

**PACKAGING INFORMATION**

Orderable Device	Status (1)	Package Type	Package Drawing	Pins	Package Qty	Eco Plan (2)	Lead finish/ Ball material (6)	MSL Peak Temp (3)	Op Temp (°C)	Device Marking (4/5)	Samples
TDA4AL88TGAALZRQ1	ACTIVE	FCBGA	ALZ	770	250	RoHS & Green	Call TI	Level-3-260C-168 HR	-40 to 125	TDA4AL88 TGAALZQ1 206	<a href="#">Samples</a>
TDA4VE88TGAALZRQ1	ACTIVE	FCBGA	ALZ	770	250	RoHS & Green	Call TI	Level-3-260C-168 HR	-40 to 125	TDA4VE88 TGAALZQ1 206	<a href="#">Samples</a>
TDA4VL21HGAALZRQ1	ACTIVE	FCBGA	ALZ	770	250	RoHS & Green	Call TI	Level-3-260C-168 HR	-40 to 125	TDA4VL21 HGAALZQ1 206	<a href="#">Samples</a>

(1) The marketing status values are defined as follows:

**ACTIVE:** Product device recommended for new designs.

**LIFEBUY:** TI has announced that the device will be discontinued, and a lifetime-buy period is in effect.

**NRND:** Not recommended for new designs. Device is in production to support existing customers, but TI does not recommend using this part in a new design.

**PREVIEW:** Device has been announced but is not in production. Samples may or may not be available.

**OBSOLETE:** TI has discontinued the production of the device.

(2) **RoHS:** TI defines "RoHS" to mean semiconductor products that are compliant with the current EU RoHS requirements for all 10 RoHS substances, including the requirement that RoHS substance do not exceed 0.1% by weight in homogeneous materials. Where designed to be soldered at high temperatures, "RoHS" products are suitable for use in specified lead-free processes. TI may reference these types of products as "Pb-Free".

**RoHS Exempt:** TI defines "RoHS Exempt" to mean products that contain lead but are compliant with EU RoHS pursuant to a specific EU RoHS exemption.

**Green:** TI defines "Green" to mean the content of Chlorine (Cl) and Bromine (Br) based flame retardants meet JS709B low halogen requirements of <=1000ppm threshold. Antimony trioxide based flame retardants must also meet the <=1000ppm threshold requirement.

(3) MSL, Peak Temp. - The Moisture Sensitivity Level rating according to the JEDEC industry standard classifications, and peak solder temperature.

(4) There may be additional marking, which relates to the logo, the lot trace code information, or the environmental category on the device.

(5) Multiple Device Markings will be inside parentheses. Only one Device Marking contained in parentheses and separated by a "~" will appear on a device. If a line is indented then it is a continuation of the previous line and the two combined represent the entire Device Marking for that device.

(6) Lead finish/Ball material - Orderable Devices may have multiple material finish options. Finish options are separated by a vertical ruled line. Lead finish/Ball material values may wrap to two lines if the finish value exceeds the maximum column width.

**Important Information and Disclaimer:** The information provided on this page represents TI's knowledge and belief as of the date that it is provided. TI bases its knowledge and belief on information provided by third parties, and makes no representation or warranty as to the accuracy of such information. Efforts are underway to better integrate information from third parties. TI has taken and continues to take reasonable steps to provide representative and accurate information but may not have conducted destructive testing or chemical analysis on incoming materials and chemicals. TI and TI suppliers consider certain information to be proprietary, and thus CAS numbers and other limited information may not be available for release.

In no event shall TI's liability arising out of such information exceed the total purchase price of the TI part(s) at issue in this document sold by TI to Customer on an annual basis.

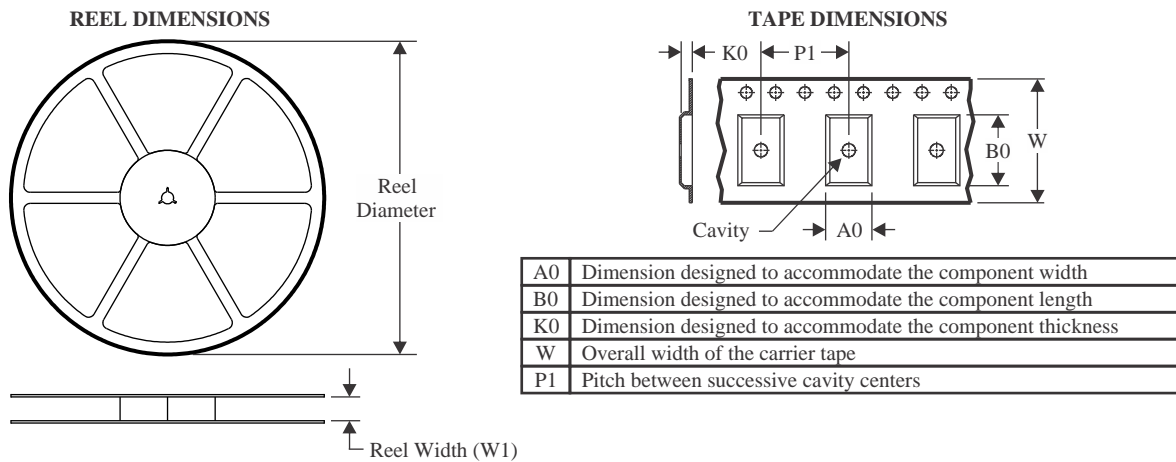
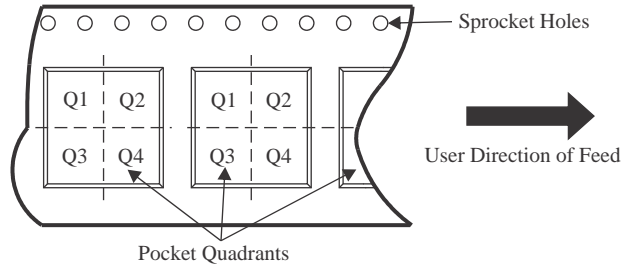
**TAPE AND REEL INFORMATION**

**QUADRANT ASSIGNMENTS FOR PIN 1 ORIENTATION IN TAPE**

\*All dimensions are nominal

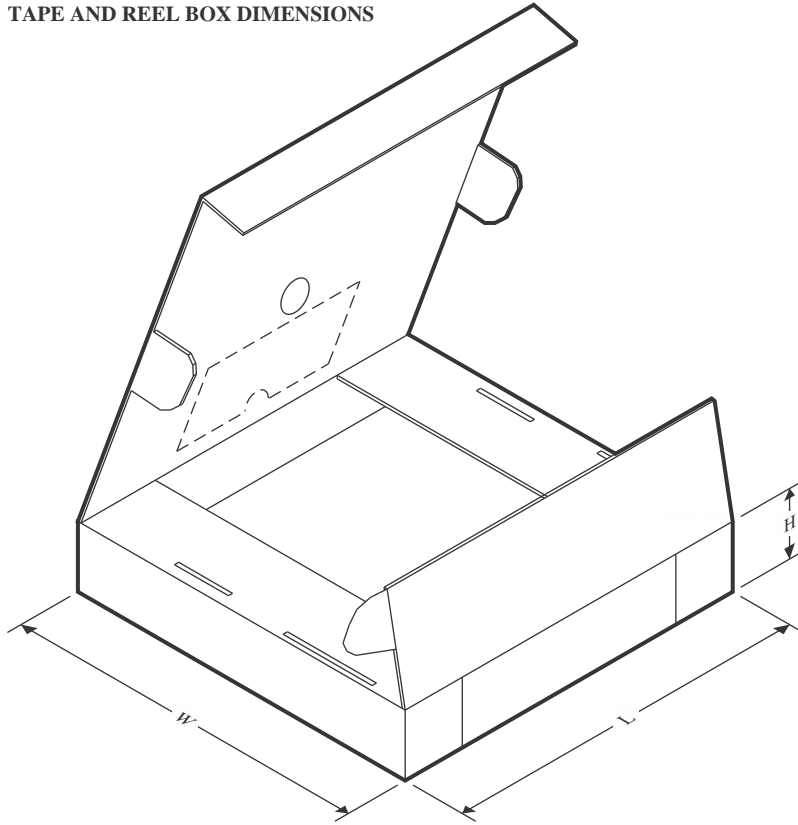
Device	Package Type	Package Drawing	Pins	SPQ	Reel Diameter (mm)	Reel Width W1 (mm)	A0 (mm)	B0 (mm)	K0 (mm)	P1 (mm)	W (mm)	Pin1 Quadrant
TDA4AL88TGAALZRQ1	FCBGA	ALZ	770	250	330.0	44.4	23.4	23.4	4.25	32.0	44.0	Q1
TDA4VE88TGAALZRQ1	FCBGA	ALZ	770	250	330.0	44.4	23.4	23.4	4.25	32.0	44.0	Q1
TDA4VL21HGAALZRQ1	FCBGA	ALZ	770	250	330.0	44.4	23.4	23.4	4.25	32.0	44.0	Q1

**TAPE AND REEL BOX DIMENSIONS**

\*All dimensions are nominal

Device	Package Type	Package Drawing	Pins	SPQ	Length (mm)	Width (mm)	Height (mm)
TDA4AL88TGAALZRQ1	FCBGA	ALZ	770	250	336.6	336.6	53.2
TDA4VE88TGAALZRQ1	FCBGA	ALZ	770	250	336.6	336.6	53.2
TDA4VL21HGAALZRQ1	FCBGA	ALZ	770	250	336.6	336.6	53.2



# EXAMPLE BOARD LAYOUT

FCBGA - 2.57 mm max height

ALZ0770A

BALL GRID ARRAY

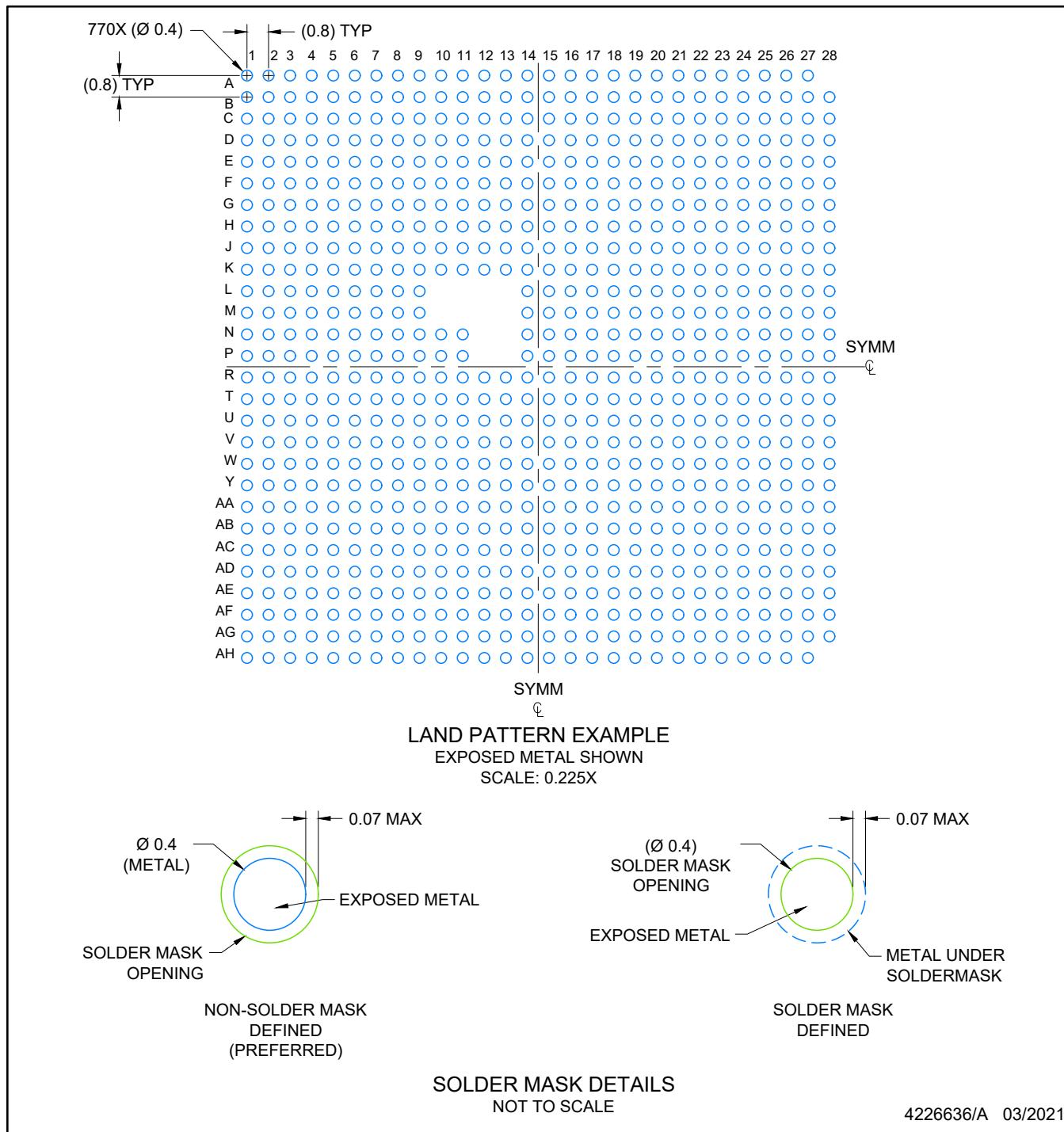

NOTES: (continued)

4. This package is designed to be soldered to a thermal pad on the board. For more information, see Texas Instruments literature number SLUA271 ([www.ti.com/lit/slua271](http://www.ti.com/lit/slua271)).
5. Vias are optional depending on application, refer to device data sheet. If any vias are implemented, refer to their locations shown on this view. It is recommended that vias under paste be filled, plugged or tented.

# EXAMPLE STENCIL DESIGN

## FCBGA - 2.57 mm max height

### ALZ0770A

BALL GRID ARRAY

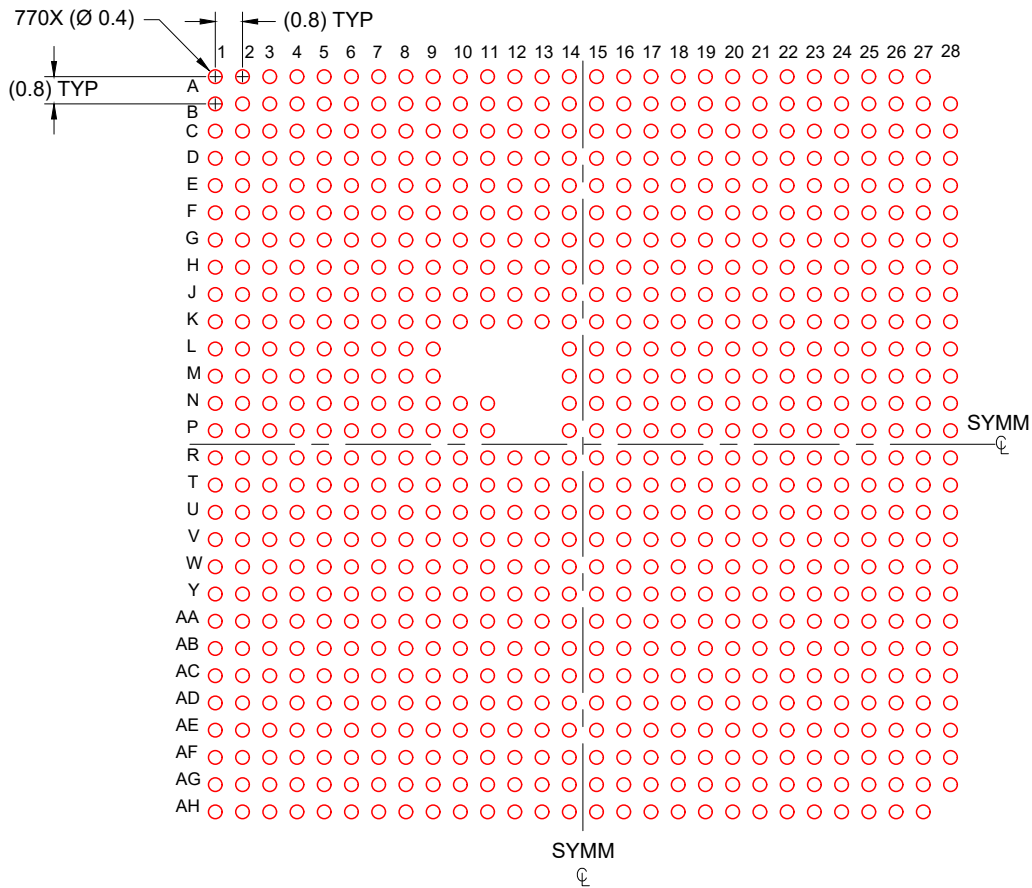

SOLDER PASTE EXAMPLE  
BASED ON 0.15 mm THICK STENCIL  
SCALE: 0.225X

4226636/A 03/2021

NOTES: (continued)

6. Laser cutting apertures with trapezoidal walls and rounded corners may offer better paste release. IPC-7525 may have alternate design recommendations.

## 重要声明和免责声明

TI“按原样”提供技术和可靠性数据（包括数据表）、设计资源（包括参考设计）、应用或其他设计建议、网络工具、安全信息和其他资源，不保证没有瑕疵且不做任何明示或暗示的担保，包括但不限于对适销性、某特定用途方面的适用性或不侵犯任何第三方知识产权的暗示担保。

这些资源可供使用 TI 产品进行设计的熟练开发人员使用。您将自行承担以下全部责任：(1) 针对您的应用选择合适的 TI 产品，(2) 设计、验证并测试您的应用，(3) 确保您的应用满足相应标准以及任何其他功能安全、信息安全、监管或其他要求。

这些资源如有变更，恕不另行通知。TI 授权您仅可将这些资源用于研发本资源所述的 TI 产品的应用。严禁对这些资源进行其他复制或展示。您无权使用任何其他 TI 知识产权或任何第三方知识产权。您应全额赔偿因在这些资源的使用中对 TI 及其代表造成的任何索赔、损害、成本、损失和债务，TI 对此概不负责。

TI 提供的产品受 [TI 的销售条款](#) 或 [ti.com](#) 上其他适用条款/TI 产品随附的其他适用条款的约束。TI 提供这些资源并不会扩展或以其他方式更改 TI 针对 TI 产品发布的适用的担保或担保免责声明。

TI 反对并拒绝您可能提出的任何其他或不同的条款。

邮寄地址：Texas Instruments, Post Office Box 655303, Dallas, Texas 75265

Copyright © 2023，德州仪器 (TI) 公司